

UNIVERSITY OF UTAH
RESEARCH INSTITUTE
EARTH SCIENCE LAB.

GLOO316

FC
USGS
OFR
80-
376

United States

Department of the Interior

Geological Survey

Theoretical Transfer Functions for Stations
in the Central California Seismographic Network

by

Jay Dratler, Jr.

Open-File Report 80-376

Menlo Park, California

1980

This report is preliminary and has not been edited or reviewed for conformity with Geological Survey standards and nomenclature.

Any use of trade names and trademarks in this publication is for descriptive purposes only and does not constitute endorsement by the U.S. Geological Survey.

The first version of this report was completed in 1975, before the author left the U.S. Geological Survey. It was revised in 1980 with the assistance of Mary O'Neill, Sam Stewart, and Bill Daul.

As much as possible, this report retains the page numbering of the earlier version.

CONTENTS

| | Page |
|---|------|
| 1. Introduction | 1 |
| 2. The Seismometer System | 2 |
| 3. Circuit Analysis of the J302 Preamplifier | 8 |
| 4. Telemetry and Recording Systems | 20 |
| 5. Overall System Response | 35 |
| 6. Interactive Routines for Plotting Transfer Functions | 50 |
| Appendix | 59 |

1. INTRODUCTION

Although instrument responses intended for reduction of actual seismic data are best obtained by calibration, theoretical instrument responses have several uses. They permit prediction of system performance and aid the design of proposed modifications to the system. They can be used to evaluate and monitor instrument performance to insure conformance with design goals. Finally, since theoretical responses usually take the form of analytical expressions they can facilitate quick calculation of and correction for instrument response, especially when the measured response differs only slightly from the theoretical.

However complex or detailed it may be, no analytical transfer function is more than an approximation to reality. Not only is each expression an approximate model of the circuit or system it describes, but many real physical effects must be ignored or treated inadequately to make calculations tractable. In this report, an effort is made to state explicitly the major assumptions and approximations under which the expressions are valid and to describe qualitatively the effects not treated in detail. Yet there may be omissions in the list of caveats, either due to oversight or to system modifications. If discrepancies between measured and calculated instrument responses are not explained by equipment malfunction or high noise in the measurements, they may be explained by discrepancies between the present block diagram and the actual signal path.

This report is divided into five sections. After the introduction, the second section discusses the seismometer, including the L-pad and preamplifier input impedance. The third section treats the preamplifier-filter combination, while the fourth section discusses the telemetry and recording apparatus. In the fifth section, the overall response is tabulated and the entire system is outlined. This section is arranged for easy reference. Finally, the last section discusses

an interactive graphics program developed on the Lawrence Berkeley Laboratory computer system for plotting the phase and amplitude of response functions on the Tektronix 4010 or 4014 CRT.

2. THE SEISMOMETER SYSTEM

Within certain limitations, the response of a mass-on-a-spring seismometer with a coil-magnet transducer may be deduced from very basic physical principles. Although this derivation is well known, it is outlined here for two reasons: 1) to make this report complete, 2) to emphasize the simplicity of the calculations from a novel viewpoint.

Figure 2.1 shows the model of the seismometer system. A magnet of mass m is suspended by a spring of spring constant K from the seismometer case within a coil of DC resistance R_c . The position of the mass relative to the case is X and relative to an inertial reference frame is X_m so that $X_c = X_m - X$ is the position of the case relative to the inertial reference frame. The generator constant of the magnet-coil combination is G_L (in $v/m/sec$), and the pad and preamplifier input resistances are as shown.

There are two forces on the mass: the spring's restoring force and the magnetic damping forces. Gravity is neglected, as it simply displaces the equilibrium position X_0 of the mass. The two forces are

$$\begin{aligned} F_s &= \text{spring force} = -K(X - X_0) \\ F_d &= \text{damping force} = -b\dot{x} \end{aligned} \tag{2.1}$$

where the latter has been assumed to be proportional to the relative velocity between the magnet and the coil.

By Newton's second law, $F = F_d + F_s = ma$, where a is the acceleration of the

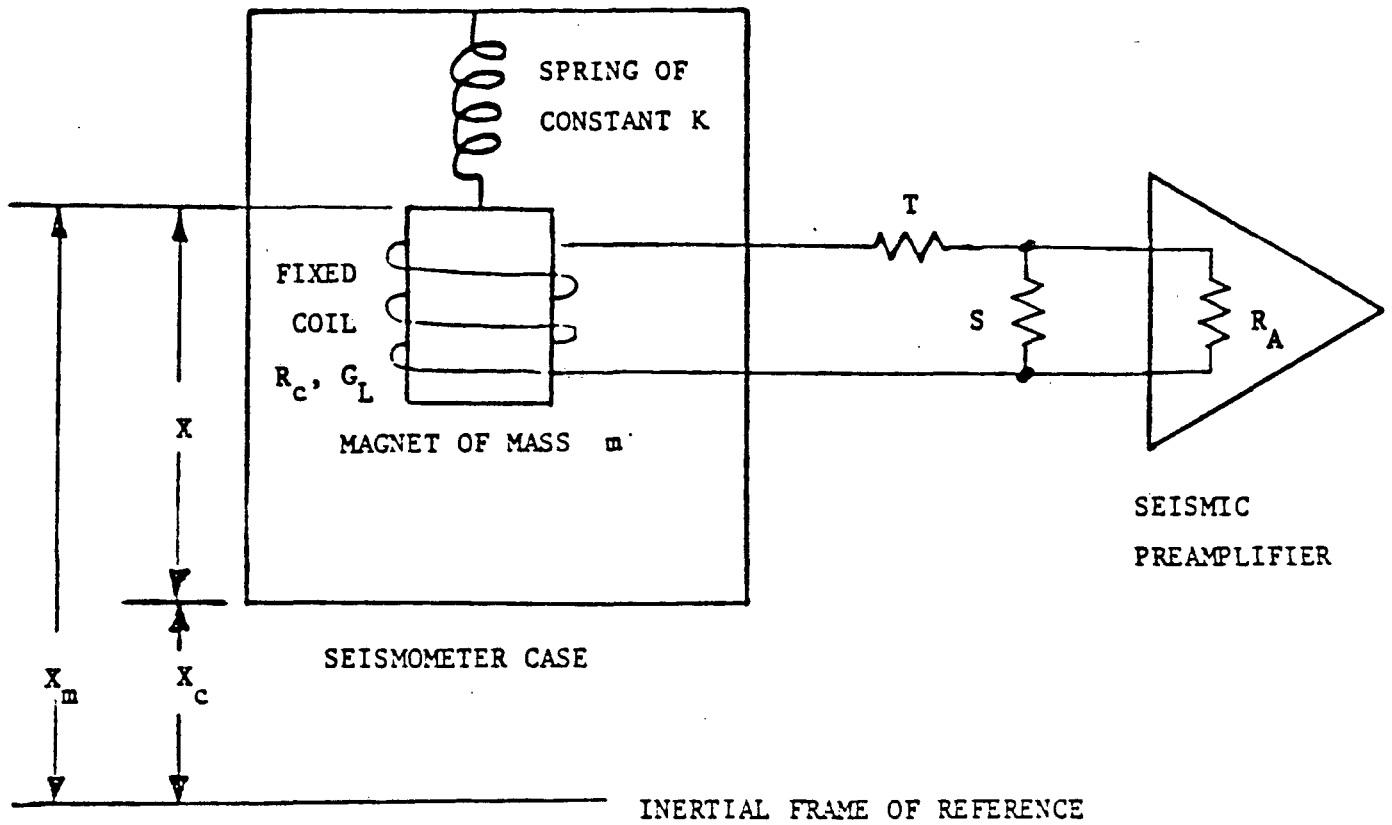

Figure 2.1 A Physical Model of the Seismometer System

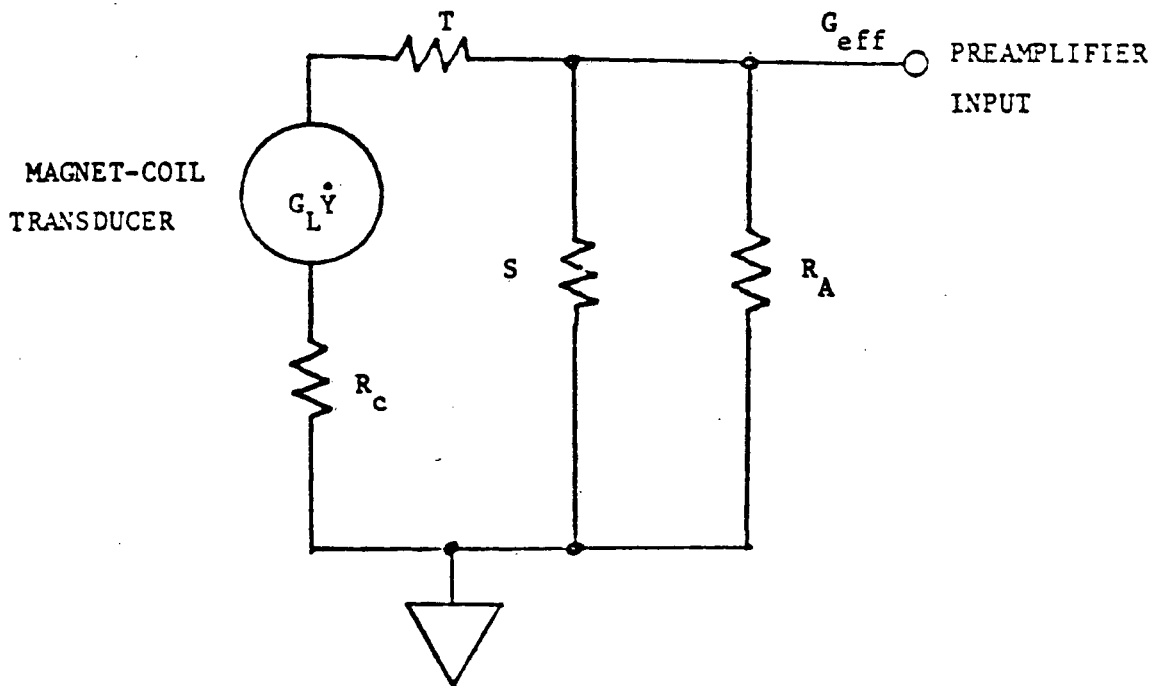

Figure 2.2 Model of the Transducer System

mass relative to any inertial reference frame.

$$F_d + F_s = ma = m\ddot{x}_m \quad (2.2)$$

Substitution of F_d and F_s from equation (2.1) with $X_m = X + X_c$ (see Figure 2.1)

and $\dot{X}_o = \dot{X}_o \equiv 0$ yields

$$-K(X - X_o) - b(\dot{X} - \dot{X}_o) = m(\ddot{X} - \ddot{X}_o + \ddot{X}_c) \quad (2.3)$$

Let $Y \equiv X - X_o$ be the position of the mass relative to the case, defined with respect to the equilibrium position X_o . Then

$$Y + \frac{b}{m} \dot{Y} + \frac{k}{m} Y = -\ddot{X}_c \quad (2.4)$$

is the equation of motion of the seismometer. This is just the standard equation for damped, driven harmonic motion, with the acceleration of the seismometer case relative to the inertial frame of reference as the driving term.

For convenience, the following definitions are made:

$$\begin{aligned} \omega_o^2 &\equiv K/m & \omega_o &= \text{natural (angular) frequency} \\ Q &\equiv \frac{\omega_o m}{b} & &= \text{quality factor or inverse damping} \\ \beta &\equiv \frac{b}{2Q} = \frac{b}{2m\omega_o} & &= \text{damping factor or fraction of critical damping} \end{aligned} \quad (2.5)$$

Here ω_o is the (angular) frequency at which the seismometer would resonate in the absence of damping, Q is a factor inversely proportional to the damping and β is the fraction of critical damping. At critical damping $Q = 1/2$ and $\beta = 1$.

Expressed in terms of these parameters, the equations of motion are

$$\begin{aligned} \ddot{Y} + \frac{\omega_o \dot{Y}}{Q} + \omega_o^2 Y &= -\ddot{X}_c \\ \text{or} \quad \ddot{Y} + 2\omega_o \beta \dot{Y} + \omega_o^2 Y &= -\ddot{X}_c \end{aligned} \quad (2.6)$$

Transfer functions for the seismometer system are obtained by considering a monochromatic input acceleration $\ddot{X}_c(t) = a_c e^{i\omega t}$, which results in oscillations $Y(t) = Y e^{i\omega t}$ at the same frequency. Then

$$\frac{Y}{a_c} = \frac{-1/\omega_o^2}{(1 - \omega^2/\omega_o^2) + \frac{2i\beta\omega}{\omega_o}} \quad (2.7)$$

where $\omega \equiv 2\pi f$ is the angular frequency of the motion.

Now the voltage output of the seismometer is determined by the magnet-coil generator. Figure 2.2 shows a simple model of the system, consisting of a voltage generator $G_L \dot{Y}$ in series with the coil resistance R_c . The output voltage e across the preamplifier input impedance R_A is calculated from simple resistive divider theory as

$$e = G_L \dot{Y} \frac{R_A S}{S + R_A} \frac{1}{T + R_c + \frac{R_A S}{S + R_A}} \quad (2.8)$$

$$= G_L \dot{Y} \frac{R_A S}{(S + R_A)(T + R_c) + R_A S} = G_{eff} \dot{Y}$$

where $G_{eff} \equiv \frac{G_L R_A S}{(S + R_A)(T + R_c) + R_A S}$

For the single frequency driving term $\ddot{X}_c(t) = a_c e^{i\omega t}$, $\dot{Y} = i\omega Y$ and the transfer functions become

$$\frac{e}{a_c} = \frac{G_{eff} i\omega Y}{a_c} = \frac{-iG_{eff} \omega/\omega_0^2}{(1 - \omega^2/\omega_0^2) + \frac{2i\beta\omega}{\omega_0}} \quad (2.9)$$

This is the seismometer voltage response to ground acceleration.

Ground displacement at a single frequency ω is related to ground acceleration as $X_c = -a_c/\omega^2$. Hence, the seismometer voltage response to ground displacement is

$$T_s(\omega) = \frac{e}{X_c} = \frac{-e\omega^2}{a_c} = \frac{iG_{eff} \omega^3/\omega_0^2}{(1 - \omega^2/\omega_0^2) + \frac{2i\beta\omega}{\omega_0}} \quad (2.10)$$

In terms of the absolute frequencies $f = \omega/2\pi$ and $f_0 = \omega_0/2\pi$, this is

$$\begin{aligned} T_s(f) &= \frac{e}{X_c} = \frac{2\pi i G_{eff} f^3/f_0^2}{(1 - f^2/f_0^2) + \frac{2i\beta f}{f_0}} \\ &= \frac{2\pi i G_{eff} f^3}{f_0^2 - f^2 + 2i\beta f f_0} \end{aligned} \quad (2.11)$$

As shown in equation (2.11), the frequency response of the seismometer is completely determined once the parameters f_0 , β , and G_{eff} are known. The natural frequency f_0 is measured for each seismometer by applying a variable-frequency current source and finding the frequency at which the current through the coil and the voltage across it are in phase. Since the driving force is proportional to the instantaneous current, the ratio of voltage to current is proportional to expression (2.11), and the two are in phase only when $f = f_0$. Measurements of f_0 are usually accurate to a few percent. The damping for any given circuit configuration can be measured by exciting the seismometer and observing the decay of the resulting oscillations on an oscilloscope or chart recorder. Usually, measurement of a few amplitude peaks is sufficient to determine β to better than 10%.

Physically, the damping arises from two sources: dissipation due to eddy currents induced in the coil and coil form or coil frame (if any), and resistive dissipation due to current flowing in the coil and external resistances.

$$F_d = F_d (\text{eddy}) + F_d (\text{res}) \quad (2.12)$$

This difference in physical mechanisms leads to a natural division of each of the damping constants b and β into two additive elements:

$$\begin{aligned}
 b &= b_0 + b_1 & (2.13) \\
 \beta &= \beta_0 + \beta_1 \\
 \text{where } \beta_0 &= \frac{b_0}{2m\omega_0} & \beta_1 = \frac{b_1}{2m\omega_0}
 \end{aligned}$$

The first of these elements describes the "open circuit damping," which occurs when no current flows in the seismometer coil, while the second describes the additional damping due to loading by finite external resistances.

Since the first term depends on the details of construction of the coil, its form, and its frame, and on the amount and nature of metallic materials used in them, the first term is not calculable in general from first principles. However, the second term may be calculated simply from the model in Figure 2.2. The effective impedance seen by the generator $G_L \dot{Y}$ is just R_c and T in series with the parallel combination of S and R_A :

$$R_{\text{eff}} = T + R_c + \frac{SR_A}{S + R_A} \quad (2.14)$$

Thus, the power dissipated by the resistances is

$$P_{d1} = \frac{-V^2}{R_{\text{eff}}} = \frac{-(G_L \dot{Y})^2}{R_{\text{eff}}} = \frac{-G_L^2 \dot{Y}^2}{R_{\text{eff}}} \quad (2.15)$$

This power can also be expressed as the product of the resistive damping force and the magnet velocity,

$$P_{d1} = F_{d1} \dot{Y}, \quad (2.16)$$

Equating expressions (2.15) and (2.16) for the power dissipated by resistive damping yields the following for the damping force:

$$F_{d1} = \frac{-G_L^2 \dot{Y}}{R_{\text{eff}}} \equiv -b_1 \dot{Y}$$

whence

$$b_1 = \frac{G_L^2}{R_{\text{eff}}} = \frac{G_L^2 (S+R_A)}{(R_c+T)(S+R_A)+SR_A} \quad (2.17)$$

Note that F_{d1} is negative as the motion and the force are in opposition. The open-circuit and resistive damping constants are then expressed as

$$\beta_0 = \frac{b_0}{2m\omega_0} \quad \beta_1 = \frac{b_1}{2m\omega_0} = \frac{G_L^2}{2m\omega_0 R_{\text{eff}}} \quad (2.18)$$

This expression shows that the additional damping due to external circuit resistance is related to the generator constant G_L , the mass m , and the circuit constants involved in R_{eff} .

Seismometer manufacturers supply fairly accurate values for m and G_L with the instruments. However, the value of G_L can change as the magnet ages or degrades with shock and temperature. Equation (2.18) can be used to estimate G_L as follows. First, the open circuit damping β_0 is measured in the usual way. Then the damping β for a given circuit configuration (a given T , S and R_A) is measured in the same way. Finally, G_L is calculated from the circuit parameters and the value $\beta_1 = \beta - \beta_0$ according to equation (2.18). As for the resistances R_c , T , S , and R_A involved in expressions (2.8) and (2.14) for G_{eff} and R_{eff} , all are easily measured; and

both T and S are specified in the circuit design.

Although equation (2.11) is a fair approximation to the seismometer response, there are several ways in which the expression can fail to represent reality. Throughout this section, linear response has been assumed for both the mechanical system and the transducer. A particular system may deviate significantly from linearity due to small defects in its manufacture, ageing, metal fatigue, stick-slip, or abuse. Even a properly made instrument is only linear in a small region about its equilibrium position. Non-linearities can result in distortion of waveforms, changes in gain with the average position of the mass, or artifacts in the data.

Slow, smooth changes in the transfer function with time may result from ageing of the magnet or spring. In a seismometer such as that modeled here, containing a single mass suspended from a single spring, the natural frequency f_0 will decrease as the spring relaxes*, and both the gain G_{eff} and the damping β will decrease as magnetization is lost. Only careful comparison of response measurements with theoretical expectations can hope to reveal, let alone identify, such changes.

3. CIRCUIT ANALYSIS OF THE J302 PREAMPLIFIER

In this section, the preamplifier and filter sections of the J302 Preamplifier, Voltage-controlled Oscillator Unit are analyzed to provide:

* Note: Where more than one elastic element supports the seismometer mass, the natural frequency may increase if the effects of auxiliary elastic supports become dominant as the main spring ages. This appears to be the case with seismometers in the Central California Network. Private communication from Jerry Eaton.

1. The gain
2. The frequency response
3. Small correction factors to the attenuator settings
4. Positions of poles and zeroes in the response function

Figure 1 of the note "J302 Preamplifier, Voltage Controlled Oscillator Unit" by John Van Schaack shows a schematic diagram of the entire circuit. A simplified diagram of the preamplifier and filter circuits is shown in Figure 3.1 of this report. Except where certain components have been lumped together for ease of analysis, part

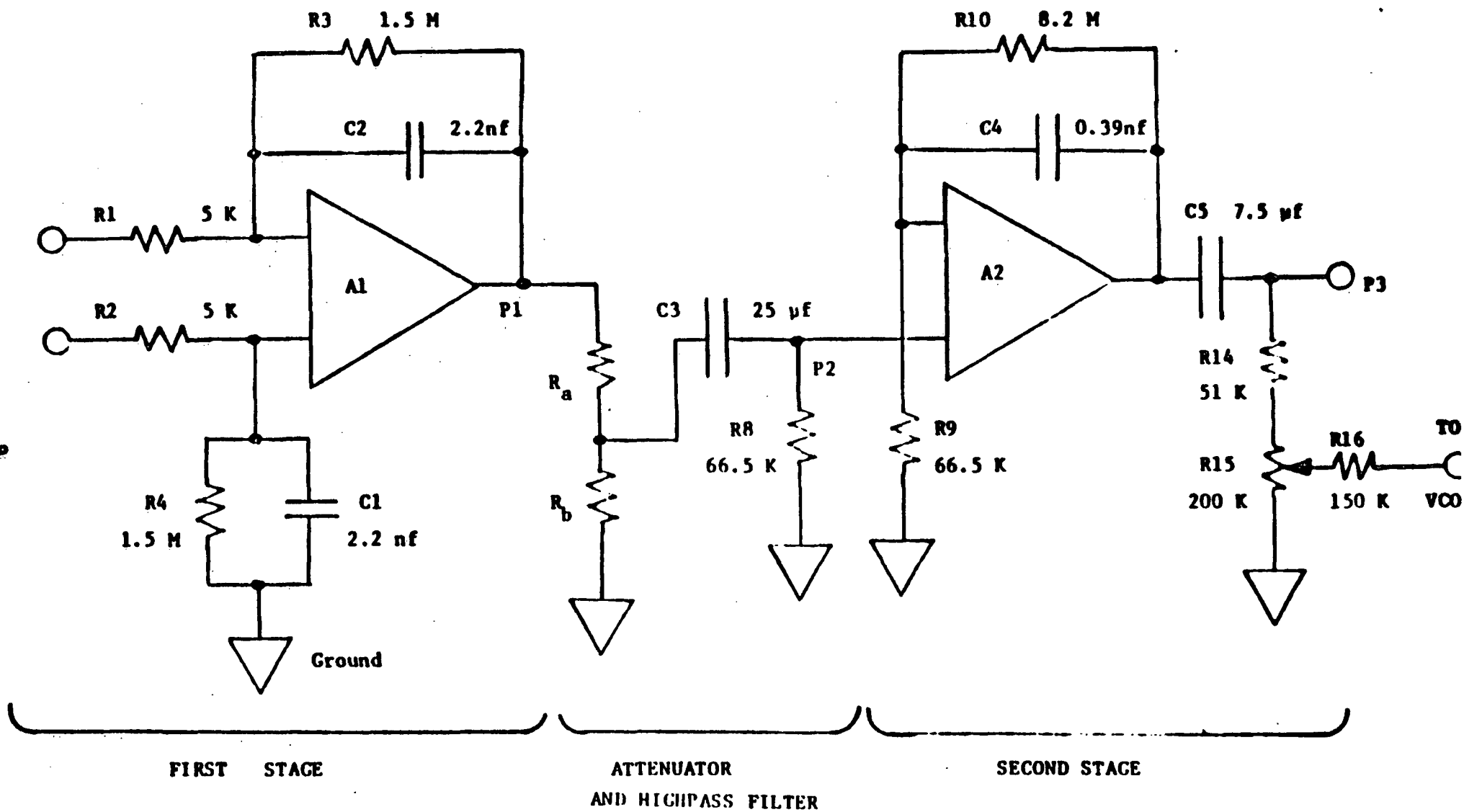

Figure 3.1 Simplified Schematic Drawing of the J302 Preamplifier-VCO Unit, showing components which affect the frequency response of the system. All resistances are in ohms, and parts designators correspond to those in Figure 1 of the note on the J302 by John Van Schaack.

designators in the two diagrams are the same. For clarity, components which do not affect the frequency response of the system have been omitted from the figure.

The first preamplifier filter stage is shown schematically in Figure 3.2. Parts designators have been changed to show the mathematical relationships between component values, and the differential input impedance Z of the operational amplifier has been included for accuracy.

Let the voltages E_1 and E_2 applied at the inputs and the other circuit voltages be as shown. By definition of the open-loop gain A of the operational amplifier, the output voltage E_o is

$$E_o = A (e_2 - e_1) \quad (3.1)$$

Other necessary equations are derived from the conservation of current at the circuit nodes. Consider first the inverting input of the amplifier. An amount of current $i_1 = (E_1 - e_1)/R$ flows into the terminal through the input resistance R . The current flowing from the terminal through the input impedance of the amplifier is $i_2 = (e_1 - e_2)/Z$. Finally, the current flowing into the terminal from the output, through the parallel combination of R_1 and C_1 , is

$$i_3 = \frac{(E_o - e_1) (1 + j\omega R_1 C_1)}{R_1}, \quad \text{where } \frac{R_1}{1 + j\omega R_1 C_1} \text{ is the impedance function of}$$

R_1 and C_1 in parallel. By conservation of current, the sum of currents flowing into the node must be zero:

$$i_1 - i_2 + i_3 = 0 \quad (3.2)$$

Substituting the above expressions for the currents yields

$$\frac{(E_1 - e_1)}{R} + \frac{(e_2 - e_1)}{Z} + \frac{(E_o - e_1)}{R_1} (1 + j\omega R_1 C_1) = 0 \quad (3.3)$$

A similar equation is derived by considering conservation of current at the non-inverting terminal:

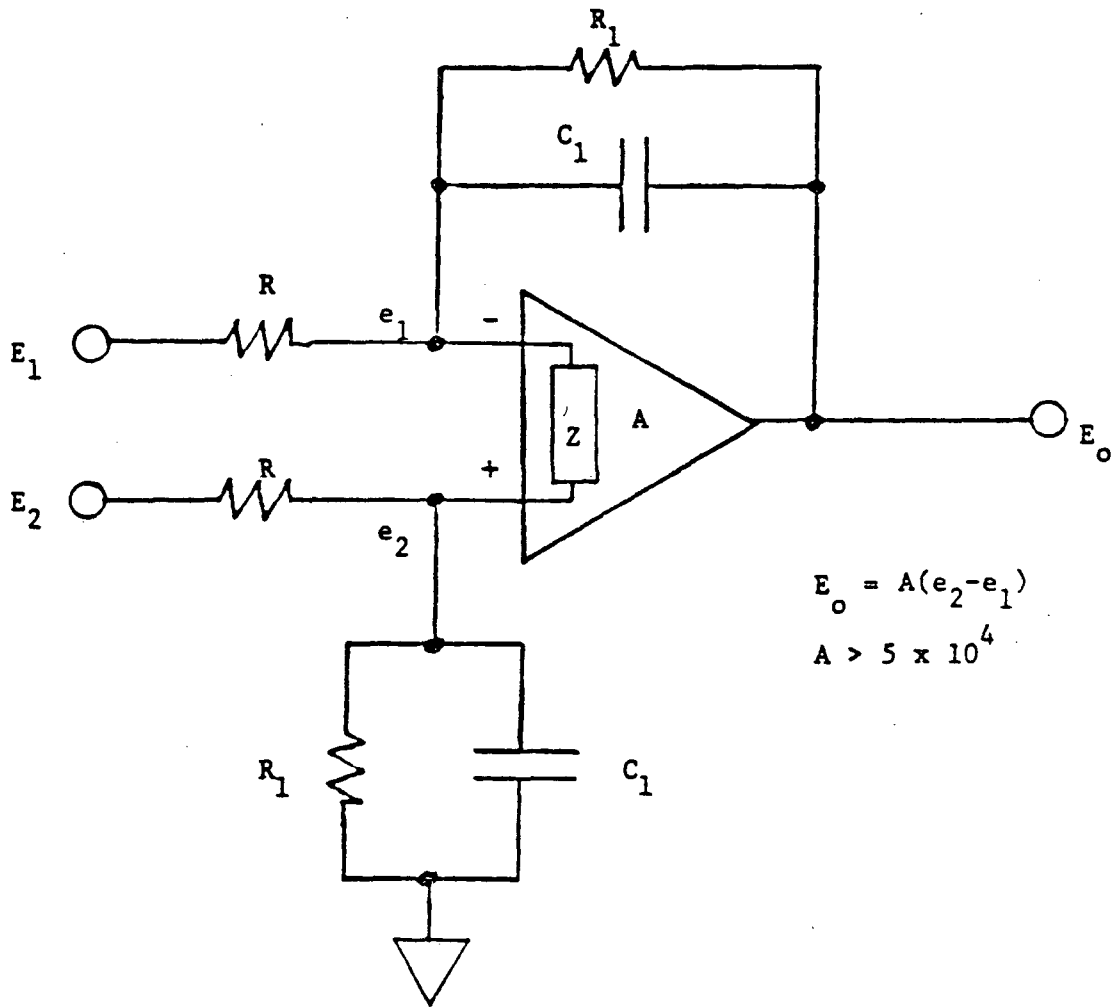

Figure 3.2 Idealized Schematic Drawing of First Stage of Preamplifier shown in Figure 3.1, with parts designators showing mathematical relationships between component values.

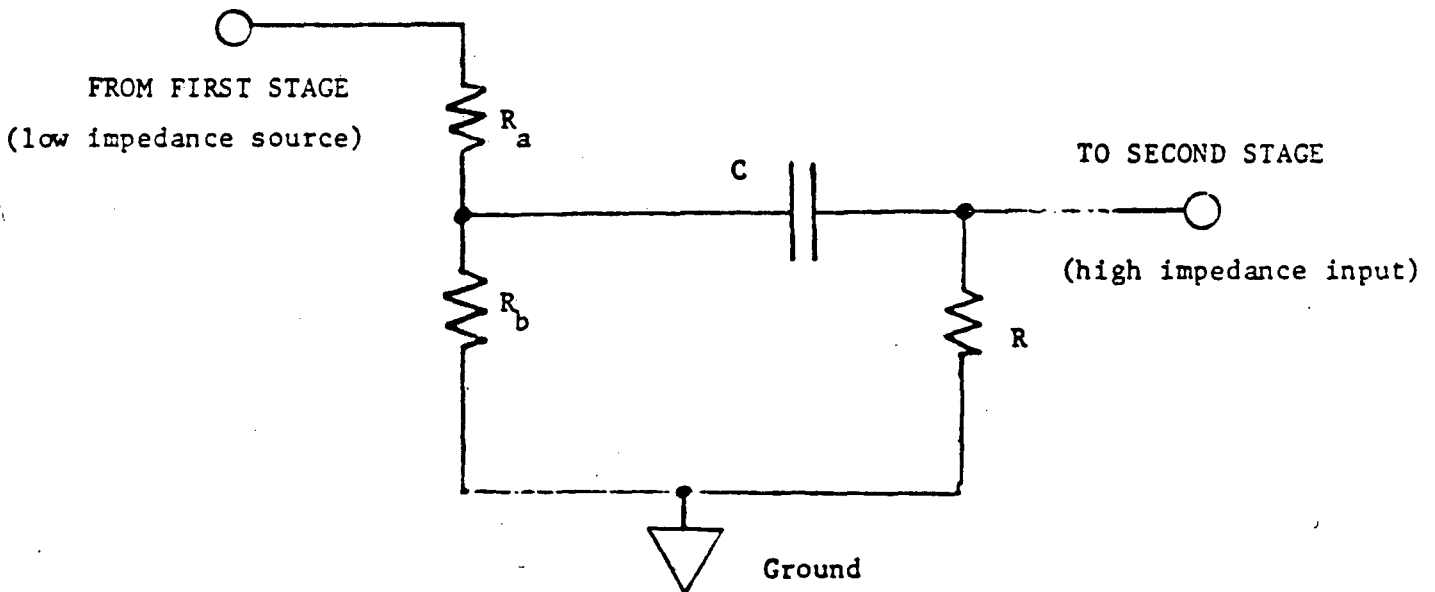

Figure 3.3 Idealized Schematic Drawing of Attenuator and Highpass Filter

$$\frac{E_2 - e_2}{R} + \frac{(e_1 - e_2)}{Z} - \frac{e_2(1+j\omega R_1 C_1)}{R_1} = 0 \quad (3.4)$$

Together, equations (3.1), (3.3) and (3.4) constitute three equations in the three unknowns e_1 , e_2 , and E_o . They can be solved for the transfer function

$$\frac{E_o}{E_2 - E_1}. \text{ The result is}$$

$$\frac{E_o}{E_2 - E_1} = \frac{R_1}{R} \frac{1}{(1 + j\omega R_1 C_1) \left(1 + \frac{1}{A}\right) + \frac{1}{A} \left[\frac{R_1}{R} + \frac{2R_1}{Z}\right]} \quad (3.5)$$

The open loop gain A of the operational amplifier is at least 5×10^4 . Hence, the terms containing the factor $1/A$ can be neglected to an accuracy of better than 1%. The transfer function for the first stage is then approximately

$$\frac{E_o}{E_2 - E_1} = T_1(\omega) = \frac{R_1}{R} \frac{1}{1 + j\omega R_1 C_1} = \frac{R_3}{R^2} \frac{1}{1 + j\omega(R_3)(C_2)} \quad (3.6)$$

where the last expression is in terms of the parts designators of Figure 3.1. Note that the RC network at the non-inverting input has no effect on the response of this circuit. It merely serves to balance the impedances seen from the two inputs of the operational amplifier to maintain thermal stability.

Since the output impedance of the first stage is low, the first stage may be conveniently separated from the rest of the circuit for analysis. In addition, the second operational amplifier is run in the "non-inverting" configuration, which has very high input impedance. Hence, the attenuator and highpass filter which lie between the two active stages may be analyzed as a separate unit. This unit is shown in Figure 3.3, in which the attenuator is represented as a simple voltage divider with variable resistances R_a and R_b .

The transfer function of this network is obtained by inspection, using the usual rules for parallel and series impedances:

$$T_n(\omega) = \frac{R}{R + \frac{1}{j\omega C}} \cdot \frac{(R + \frac{1}{j\omega C}) R_b}{R_b + R + \frac{1}{j\omega C}} \cdot \frac{1}{R_a + \frac{(R + \frac{1}{j\omega C}) R_b}{R_b + R + \frac{1}{j\omega C}}} \quad (3.7)$$

$$= \frac{R R_b}{R_a (R_b + R + \frac{1}{j\omega C}) + (R + \frac{1}{j\omega C}) R_b} = \frac{R_b (j\omega RC)}{R_a + R_b + j\omega C [R_a R_b + R(R_a + R_b)]}$$

This equation can be rearranged to the form

$$T_n(\omega) = \frac{R_b}{R_a + R_b} \cdot \frac{1}{1 + \frac{R_p}{R}} \cdot \frac{j\omega RC [1 + R_p/R]}{1 + j\omega RC [1 + R_p/R]} \quad (3.8)$$

where $R_p \equiv \frac{R_a R_b}{R_a + R_b}$ is the resistance of R_a and R_b in parallel. Thus, the interstage network acts, as expected, like an attenuator followed by a highpass filter.

Loading of the divider by the highpass filter has two effects. First, the attenuation factor is not simply $\frac{R_b}{R_a + R_b}$, as expected, but contains the additional correction factor $(1 + R_p/R)^{-1}$. Secondly, the effective time constant of the highpass filter is increased by the factor $(1 + R_p/R)$. Both these effects depend on the ratio R_p/R , which varies with the attenuator setting. An examination of the actual attenuator in the J302 note shows that R_p is at most 8K, when $R_a = R_b = 16K$. This occurs when the divider attenuation is 6db. Thus, the worst-case correction factor is

$$(1 + R_p/R)(\max) = 1 + \frac{8K}{66.5K} = 1.12, \quad (3.9)$$

so that the attenuation is increased by 1.6 db and the filter cutoff frequency is decreased by about 11% for this setting. At higher attenuation, the corrections to the simple attenuator-highpass filter approximation become negligible.

The response function of the inter-stage network (equation (3.8)) can be rewritten

$$T_n(\omega) = \frac{R_b}{R_a + R_b} \frac{1}{C} \cdot \frac{j\omega(RB)(C)C}{1 + j\omega(RB)(C)C} \quad (3.10)$$

where $\frac{R_b}{R_a + R_b}$ is the divider attenuation factor, C^* is the correction factor $1 + R_p/R$, and the part designations are those of Figure 3.1. In many cases, the correction factor C^* need not be considered, as it is swamped by component tolerances, which are typically 5 to 10 percent. However, in accurate work one may wish to include this factor, so its values as a function of attenuator setting are listed in Table 3.1.

In the second preamplifier-filter stage there are two sections. One is the lowpass filter in the feedback network of the operational amplifier, and the other is the highpass filter driven by the operational amplifier (see Figure 3.1). An idealized schematic of the second stage is shown in Figure 3.4. The two types of filtering are mathematically separable due to the low output impedance of the operational amplifier.

According to the standard theory of feedback operational amplifiers in the non-inverting configuration, the response of the amplifier circuit is given by

$$T_a(\omega) = 1 + \frac{Z_f}{R_1} \quad (3.11)$$

where Z_f is the feedback impedance of the amplifier. Here Z_f is just the parallel combination of R_2 and C_2 , so that

$$T_a(\omega) = 1 + \frac{R_2}{R_1(1 + j\omega R_2 C_2)} = \left(1 + \frac{R_2}{R_1}\right) \frac{1 + j\omega \frac{R_1 R_2}{R_1 + R_2} C_2}{1 + j\omega R_2 C_2} \quad (3.12)$$

The DC gain is just $1 + R_2/R_1$, as would be expected if there were no feedback capacitor. The pole at $\omega_1 \equiv \frac{1}{R_2 C_2}$ describes the lowpass filter, while the zero at $\omega_u \equiv \frac{1}{\frac{R_1 R_2}{R_1 + R_2} C_2}$ indicates that the lowpass response does

not roll off indefinitely, but returns to unity gain above some breakpoint frequency due to the non-inverting feedback configuration. For the component values in Figure 3.1, the frequency corresponding to this breakpoint is

Table 3.1 ATTENUATION CORRECTION FACTOR

| Divider Attenuation (db) | R_a | R_b | $R_p = \frac{R_a R_b}{R_a + R_b}$ | Correction Factor $C = 1 + R_p / R$ | Additional Attenuation $\frac{1}{C}$ (db) |
|--------------------------------|---------|---------|-----------------------------------|---|---|
| 0 | 0 | 32.276K | 0 | 1.00 | 0 |
| 6 | 16.2K | 16.076K | 8.06K | 1.12 | .1 |
| 12 | 24.26K | 8.016K | 6.03K | 1.091 | .76 |
| 18 | 28.28K | 3.996K | 3.5 K | 1.053 | .46 |
| 24 | 30.28K | 1.996K | 1.88K | 1.027 | .22 |
| 30 | 31.28K | 996 | 975 | 1.015 | .14 |
| 36 | 31.78K | 497 | 486 | 1.007 | .06 |
| 42 | 32.03K | 248 | 246 | 1.004 | .04 |
| 48 | 32.154K | 124 | 123 | 1.002 | .02 |

R = 66.5K

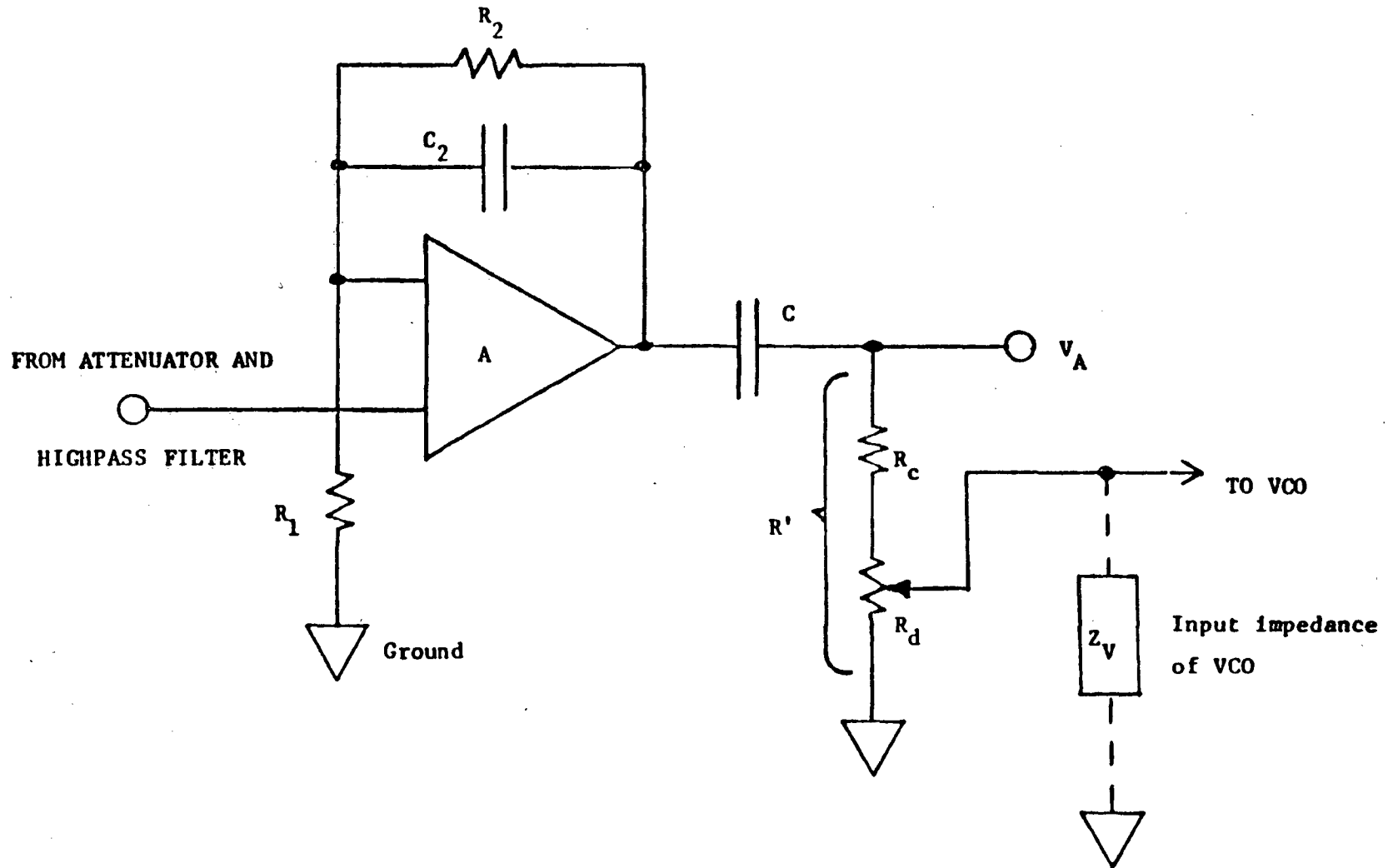

Figure 3.4 Idealized Schematic Drawing of Second Stage of Preamplifier shown in Figure 3.1, with parts designators showing mathematical relationships between component values.

$$f = \frac{|\omega|}{2\pi} = \frac{1}{2\pi} \frac{1}{\frac{(R9)(R10)}{R9 + R10} C4} = 6.2 \text{ KHZ.}$$

Since this frequency is well above the region of seismological interest, the upward breakpoint and the zero in equation (3.12) may be ignored for most practical purposes.

The CR network driven by the operational amplifier is a simple single-pole highpass filter, whose response is given by

$$T_b(\omega) = \frac{j\omega R' C}{1 + j\omega R' C} \quad (3.13)$$

Where R' is the effective resistance from the output labeled V_A in Figure 3.4 to ground. Due to the finite input impedance of the VCO, this resistance will depend somewhat on the setting of potentiometer R_d ($R15$ in Figure 3.1). However, to a fair approximation, particularly for low settings of R_d , the resistance R' can be taken as just the sum of R_d and R_c . The output of point V_A is then given by equation (3.13) with $R' = R_c + R_d$. Resistors R_c and R_d comprise an attenuator for the purpose of setting the VCO band edges. Since their effect is purely resistive, they do not contribute to the shape of the preamplifier response; so they need only be considered when the VCO - discriminator gain is taken into account (see Section 5). The response of the second stage to point V_A is then just the product of the responses of the amplifier and highpass filter

$$T_2(\omega) = T_a(\omega)T_b(\omega) = \left(1 + \frac{R_2}{R_1}\right) \frac{1 + j\omega \frac{R_1 R_2}{R_1 + R_2} C_2}{1 + j\omega R_2 C_2} \cdot \frac{j\omega R' C}{1 + j\omega R' C} \quad (3.14)$$

Using the component notation of Figure 1, this equation becomes

$$T_2(\omega) = \left(1 + \frac{R10}{R9}\right) \frac{1 + j\omega \frac{(R10)(R9)}{R10 + R9} C4}{1 + j\omega(R10)(C4)} \cdot \frac{j\omega(R14 + R15) C5}{1 + j\omega(R14 + R15) C5} \quad (3.15)$$

So far, the responses of the separable sections of the preamplifier have been derived in equations (3.6), (3.10) and (3.15). The response of the preamplifier as a whole is just the product of the section responses:

$$T(\omega) = T_1(\omega) T_n(\omega) T_2(\omega)$$

$$= \frac{R_3}{R_2} \cdot \frac{A}{C} \cdot \left(1 + \frac{R_{10}}{R_9}\right) \frac{(j\omega(R_8)(C_3)C') (j\omega(R_{14}+R_{15})C_5) (1+j\omega \frac{(R_{10})(R_9)}{R_{10}+R_9} C_4)}{(1+j\omega(R_3)(C_2)) (1+j\omega(R_8)(C_3)C') (1+j\omega(R_{10})(C_4)) (1+j\omega(R_{14}+R_{15})C_5)}$$

$$= G \frac{(jf/f_2)(jf/f_5)(1+jf/f_3)}{(1+jf/f_1)(1+jf/f_2)(1+jf/f_4)(1+jf/f_5)}$$

$$\text{where } G \equiv \frac{R_b}{R_a+R_b} \left(\frac{R_3}{R_2}\right) \left(1 + \frac{R_{10}}{R_9}\right) \left(\frac{1}{1 + \frac{R_a R_b}{(R_8)(R_a+R_b)}}\right) = (37,200) \frac{R_b}{R_a+R_b} \quad (3.16)$$

$$A \equiv \frac{R_b}{R_a+R_b} = \text{attenuation}$$

$$f_1 = [2\pi(R_3)(C_2)]^{-1} = 48.4 \text{ HZ}$$

$$f_2 = [2\pi(R_8)(C_3)C']^{-1} = [2\pi(R_8)(C_3)]^{-1} = .096 \text{ HZ}$$

$$f_3 = [2\pi \frac{(R_{10})(R_9)}{R_{10}+R_9} C_4]^{-1} = 6.18 \text{ KHZ}$$

$$f_4 = [2\pi(R_{10})(C_4)]^{-1} = 49.8 \text{ HZ}$$

$$f_5 = [2\pi(R_{14}+R_{15})C_5]^{-1} = .085 \text{ HZ}$$

The overall gain G of the J302 unit is determined primarily by the attenuator setting $A \equiv \frac{R_b}{R_a+R_b}$. Nominal values of the station attenuator setting A_{sta} are recorded in the station log, but these differ slightly from the actual attenuation A . In table 3.2, the actual divider attenuation A , the attenuator correction factor $\frac{1}{C}$, and the actual J302 gain G are shown as a function of the nominal station attenuator setting A_{sta} .

TABLE 3.2 ACTUAL J302 GAIN VERSUS
NOMINAL STATION ATTENUATOR SETTING

| Nominal Station Attenuator Setting | Actual Divider Attenuation Factor | Attenuator Correction Factor | Actual J302 Gain G | |
|---|--|---|----------------------|------|
| A_{sta} (db) | $A \equiv \frac{R_b}{R_a + R_b}$ (amplitude ratio) | $\frac{1}{C} = \frac{1}{1 + R/R_p}$ $R_p = \frac{R_a R_b}{R_a + R_b}$ $R = 66.5K$ | (amplitude ratio) | (db) |
| 0 | 1.000 | 1.000 | 37,292. | 91.4 |
| 6 | 0.4981 | 0.892 | 16,565. | 84.4 |
| 12 | 0.2484 | 0.917 | 8,492. | 78.6 |
| 18 | 0.1238 | 0.950 | 4,386. | 72.8 |
| 24 | 6.184×10^{-2} | 0.973 | 2,243. | 67.0 |
| 30 | 3.086×10^{-2} | 0.985 | 1,134. | 61.1 |
| 36 | 1.540×10^{-2} | 0.993 | 570.0 | 55.1 |
| 42 | 7.683×10^{-3} | 0.996 | 285.5 | 49.1 |
| 48 | 3.842×10^{-3} | 0.998 | 143.0 | 43.1 |

4. TELEMETRY AND RECORDING SYSTEMS

In an ideal seismographic network, analysis of the system response ends with consideration of the seismic amplifiers and filters, which are designed to enhance the desired signals. However, in real networks the equipment used to transmit and preserve the data for future use has its own effects on the system response. Some of these effects are inherent in the system design and result from trade-offs between performance factors such as noise, data volume, bandwidth, and dynamic range. Other effects, like distortion, cross-talk, and interference, may be unplanned, but alter the system response nevertheless.

Figure 4.1 is a block diagram of the telemetry and recording systems. Data from the seismic preamplifier and filter in the form of low-frequency voltage variations are converted to frequency modulation of an audio-frequency carrier in the VCO (voltage-controlled oscillator). The resultant FM (frequency-modulated) signal is filtered to improve its spectral purity and reduce crosstalk with neighboring carriers and then multiplexed, i.e. added algebraically with other carriers in a summing amplifier. The resultant bundle of multiplexed FM carriers, which may contain from one to eight different channels of data, is telemetered to the central recording facility by phone line and/or radio link.

Each bundle of tones is recorded directly on a single track of 1" wide instrumentation-quality magnetic tape. The data are preserved as a bundle of carriers for future use, and they may be dubbed onto library tapes in the same format. For analysis, the data are reproduced on an instrumentation tape recorder with both capstan servo control and subtractive tape speed compensation. The carrier bundle from each track is demultiplexed and each tone is demodulated by a bank of eight discriminators selected for the appropriate playback speed.

To provide for multiplexing and demultiplexing up to eight data channels, each VCO-discriminator pair contains three filters. The VCO output filter, a bandpass filter centered about the unmodulated carrier frequency of the particular

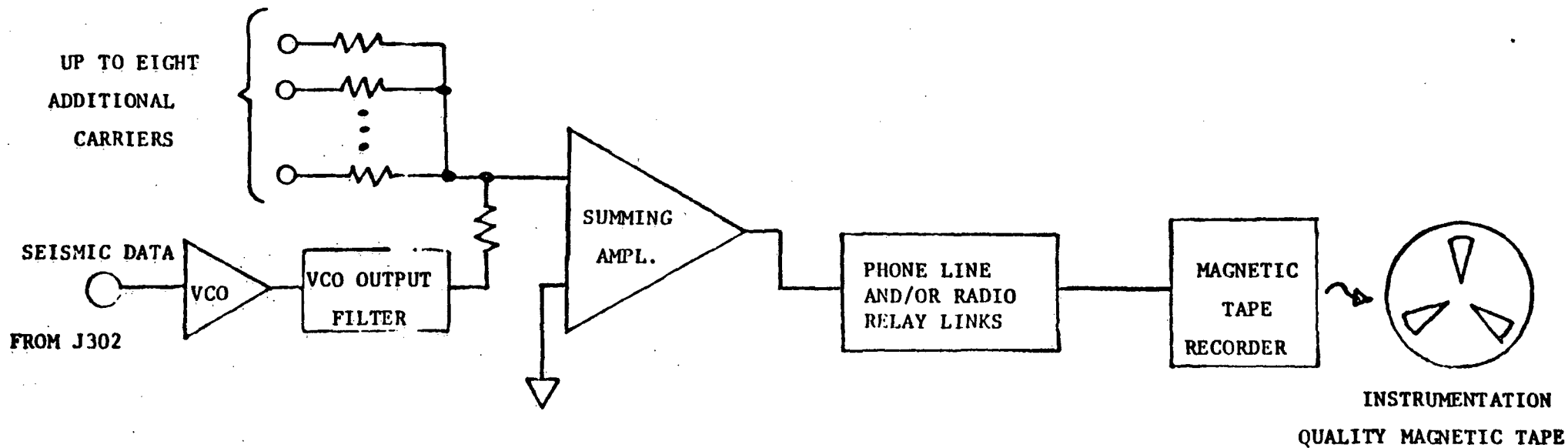

21

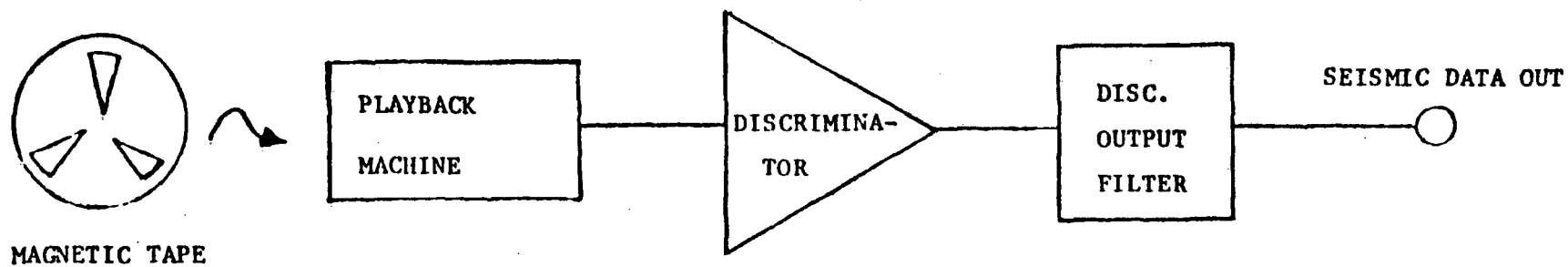

Figure 4.1 Flow Chart of Signal Path through Telemetry and Recording Equipment.

channel, has already been mentioned. The discriminator contains a similar filter, which helps demultiplex the carrier bundle by passing only a single carrier. The third filter is a multi-pole lowpass filter at the output of the discriminator, which eliminates the carrier frequency from the demodulator output. Though these filters are intended merely to provide efficient transmission and reception of multi-channel data without crosstalk, each has a definite effect on the overall system response.

A constant-bandwidth FM system is used for the Central California network. Each tone bundle consists of up to eight carriers, with center frequencies at 680, 1020, 1360, 1700, 2040, 2380, 2720, and 3060 Hz. For each carrier, full scale modulation corresponds to a change in frequency of ± 125 Hz. Since the carriers are separated by 340 Hz, there is a gap of 90 Hz between adjacent band edges. The function of the VCO output filter is to pass all the frequencies in a given channel ($f_0 \pm 125$ Hz) but to attenuate strongly signals outside that band. For effective channel separation, the filter must attenuate frequencies at the adjacent band edges ($f_0 \pm (125+90)$ Hz) by at least 40 db relative to all signals in the channel. The filter is best designed with a flat passband and an extremely rapid cutoff outside the passband.

Because the bandwidth of the VCO output filter (± 125 Hz) is large compared to the bandwidth of seismic interest, and because the amplitude of the data is represented by the frequency rather than the amplitude of the FM carrier, the VCO output filter has little effect on the amplitude response of the system. Its delay, however, does have an effect on the phase response of the system. Unfortunately, the transfer function of the VCO output filter for the J302 has not been analyzed in detail, and this is a possible area of future work. Yet a worst-case estimate of the phase delay of the filter is obtained simply by taking the reciprocal of the half-bandwidth:

$$\Delta t_{wc} = 1/f = 1/125 \text{ Hz} = 8 \text{ ms} \quad (4.1a)$$

The corresponding worst-case phase shift, which occurs at the upper (30 Hz) end of the seismic band, is

$$\Delta \phi_{wc} = f \Delta t_{wc} \cdot 360^\circ = 8 \text{ ms} \cdot 30 \text{ Hz} \cdot 360^\circ \approx 90^\circ \quad (4.1b)$$

Such a phase shift can be significant only in studies of the phase properties of individual seismograms near the upper end of the seismic band.

Timing errors due to this delay can normally be ignored. The crucial factor in seismological analysis is not the absolute value of the delay at any one station, but the relative delays between stations. As long as all stations of interest use the J302 preamplifier-VCO unit, variations in delay from station to station will remain typically below 10% of Δt_{wc} and thus will be significant only at the 1 ms level.

The discriminator input filter, which separates the particular channel to be demodulated from the other channels in the bundle, is similar in structure, function, and effect to the VCO output filter. When data are played back and discriminated at a higher tape speed than that used for recording, both the channel separation and the bandwidth must be scaled by the speedup factor, so the absolute delays are proportionally lower. However, on the time scale at which the data are recorded, the absolute delays produced in playback at a higher speed appear proportionally longer. These two effects cancel so that the delay properties of a given type of bandpass filter are independent of the speed used for playback. The worst-case phase and group delays for the discriminator input filter are thus the same as those deduced above for the VCO output filters.

Three types of discriminators are currently (1975) in use at the Earthquake Research Center: the Develco model 6203, set for a speedup of x 4, the Airpax model FDS 30, set for a speedup of x 16, and the home-made model J301, designed by John Van Schaack for use in real time. None of these devices have standard input filters amenable to simple mathematical description. However, Tri-Com model 402 discriminators designed for use with a speedup factor of x 16 have been ordered for the Central California seismographic network, and these devices have simple 5-pole Bessel input filters.

Of the three filters in the telemetry-recording system, the discriminator output filter has the greatest effect on the system response. In order to eliminate vestiges of the carrier signal from the data output and produce a faithful reproduction of the slowly varying seismic signal, this filter must roll off at a fairly low frequency, which determines the bandwidth of the VCO discriminator pair and hence the bandwidth of the system.

All discriminators used with the Central California network have multipole lowpass output filters with a cutoff frequency in real time of 30 Hz. (The frequency is scaled with the speedup factor for playback where necessary.) The filters in the J301, Airpax, and Develco discriminators have not been mathematically analyzed, and the filter in the Develco discriminator is particularly intractable to analysis, being based on a rather strange design. The Tri-Com discriminators on order have 5-pole Bessel output filters designed by the manufacturer, and 5-pole Butterworth filters are available. Both filters have a transfer function of the following form:

$$T_f(\tilde{s}) = \frac{-\tilde{s}_6 \tilde{s}_7 \tilde{s}_8 \tilde{s}_9 \tilde{s}_{10}}{(\tilde{s}-\tilde{s}_6)(\tilde{s}-\tilde{s}_7)(\tilde{s}-\tilde{s}_8)(\tilde{s}-\tilde{s}_9)(\tilde{s}-\tilde{s}_{10})} \quad (4.2)$$

$$T_f(f) = \frac{1}{(1+if/f_6)(1+if/f_7)(1+if/f_8)(1+if/f_9)(1+if/f_{10})}$$

where $\tilde{s} = i\omega/\omega_c$ is the scaled complex frequency, the \tilde{s}_i are the scaled complex positions of poles in the filter response, and $\omega_c = 2\pi f_c$ is the angular cutoff frequency (the scaling frequency), here 60π rad/sec. The subscripts 6-10 are used rather than 1-5 to avoid confusion with the characteristic frequencies already derived for the J302 in Section 3. For the Bessel filter ordered, the pole positions are

$$\begin{aligned} \tilde{s}_6 &= -1.5023 \\ \tilde{s}_{7,8} &= -1.3808 \pm i .7179 \\ \tilde{s}_{9,10} &= -.9576 \pm i 1.4711 \end{aligned} \quad (4.3)$$

The pole positions for the alternate Butterworth filter are

$$\begin{aligned} \tilde{s}_6 &= -1 \\ \tilde{s}_{7,8} &= -A \pm iB \\ \tilde{s}_{9,10} &= -D \pm iC \end{aligned} \quad (4.4)$$

where $A \equiv \sin(\pi/10)$ $B \equiv \cos(\pi/10)$

$C \equiv \sin(\pi/5)$ $D \equiv \cos(\pi/5)$

The corresponding characteristic frequencies used in the second expression of (4.2) are given by $f_k = -\tilde{s}_k f_c$.

Plots of the phase and amplitude response for both the Bessel and Butterworth filters are shown in Figures 4.2 - 4.9 (see note on p. 25a). For each filter, responses are shown over a narrow range of frequencies near the cutoff

frequency as well as over a broad range of frequencies including the seismic band. Note that the filters differ little in the gross characteristics of their responses, but that the Butterworth filter has a flatter response and sharper cutoff. On the other hand, the Bessel filter has more linear phase, and hence constant delay, near cutoff.

The Bessel output filter was chosen for the present application because accuracy of timing, rather than ease of calibration of spectral amplitudes, was thought to be of paramount importance. Unlike the Butterworth filter, the Bessel filter has constant group delay throughout its passband, and both the absolute delay and the unit-to-unit variations in delay are smaller for the Bessel filter than for the Butterworth. The only advantage of the Butterworth filter is the flatter amplitude response near the cutoff frequency, which renders spectral calibration of the system less critical. However, with the automatic calibration system now being installed throughout the Central California network, correction of spectra for instrument response will be simple and quick, while the problem of correcting seismograms for phase response has not yet been attacked. Thus, in view of the purpose and capabilities of the present array, the sole advantage of the Butterworth filter is debatable.

*Note: The scaled pole positions are expressed by the manufacturer in the form $s_k = -f_k/f_c$, which is scaled by the cutoff frequency $f_c = 30$ Hz. Accordingly, the plots in Figures 4.2-4.9 were produced by a computer program which used the pole positions in Equations 4.3 and 4.4 (see page 71), but which scaled all frequencies by the cutoff frequency " f_c " during the calculations (see page 63, line 127). The cutoff frequency is entered manually during the interactive plotting process (see page 60, lines 48, 49, and page 52).

Beside the three filters in the telemetry equipment, there is little in the telemetry-recording system to alter the overall response. The instrumentation tape recorders have nominal direct-record bandwidths of 4000 Hz and usable response up to 6000 Hz, and the phase and group delays associated with such bandwidths are negligible compared to those of the telemetry filters. Amplitude variations in the phone lines, radio links, and record-reproduce process are unimportant since the seismic information is carried as frequency modulation on the tones. Occasionally, frequency shifts of the tone bundles are produced by microwave links in the telephone channels, but these produce offsets in the data without altering the system response. Thus, for practical purposes, the effect of the telemetry-recording system on the overall response is simply the effect of the three data filters. In those cases in which small delays introduced by the two carrier filters are unimportant, the entire system of Figure 4.1 can be represented by the single transfer function (4.2).

FIGURE 4.2. AMPLITUDE RESPONSE OF 5-POLE BESSEL LOWPASS FILTER

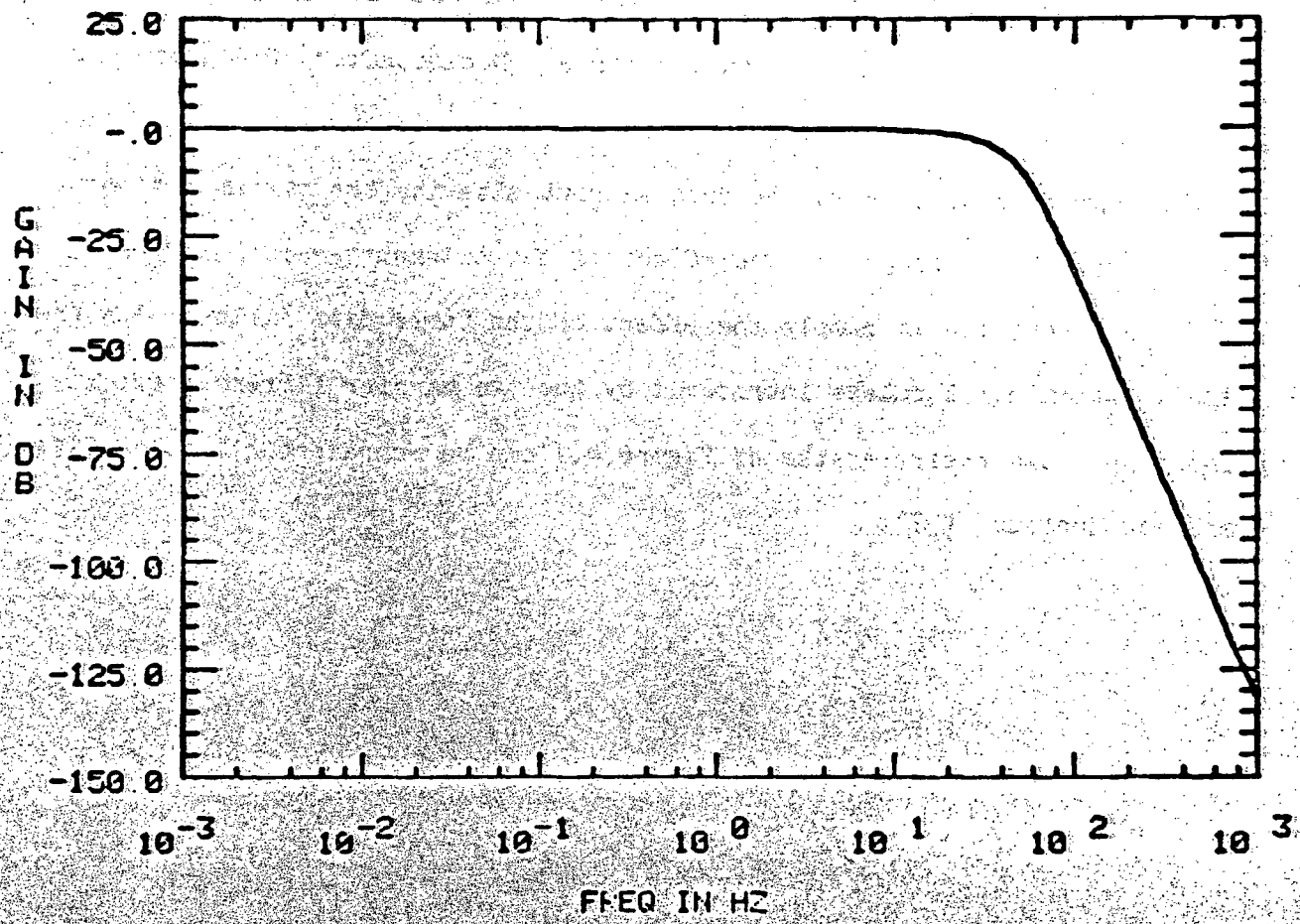

FIGURE 4.3 PHASE RESPONSE OF 5-POLE BESSEL LOWPASS FILTER

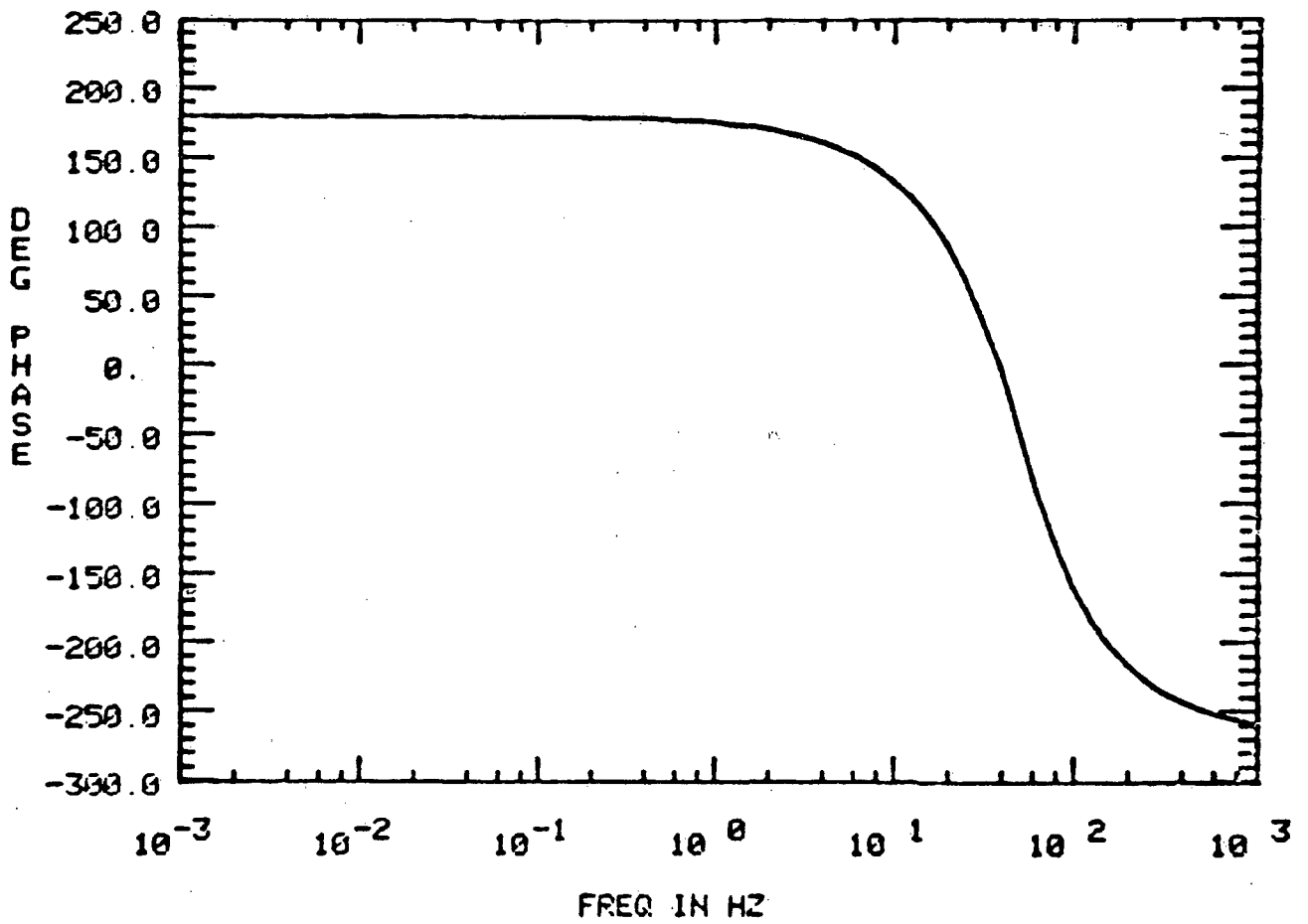

FIGURE 4.4 AMPL. RESPONSE NEAR CUTOFF OF 5-POLE BESSEL LOWPASS FILTER

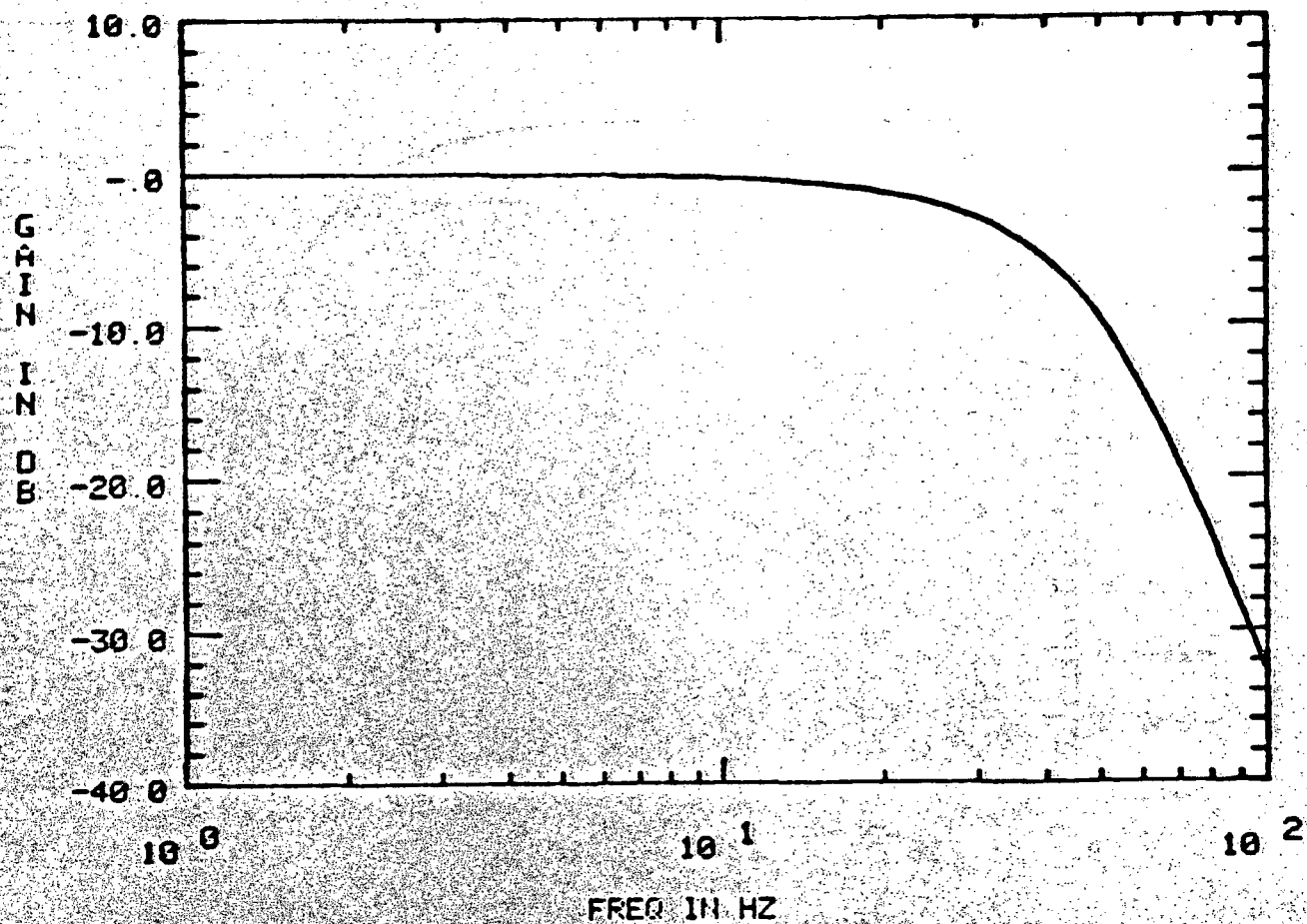

FIGURE 4.5 PHASE RESPONSE NEAR CUTOFF OF 5-POLE BESSEL LOPASS FILTER

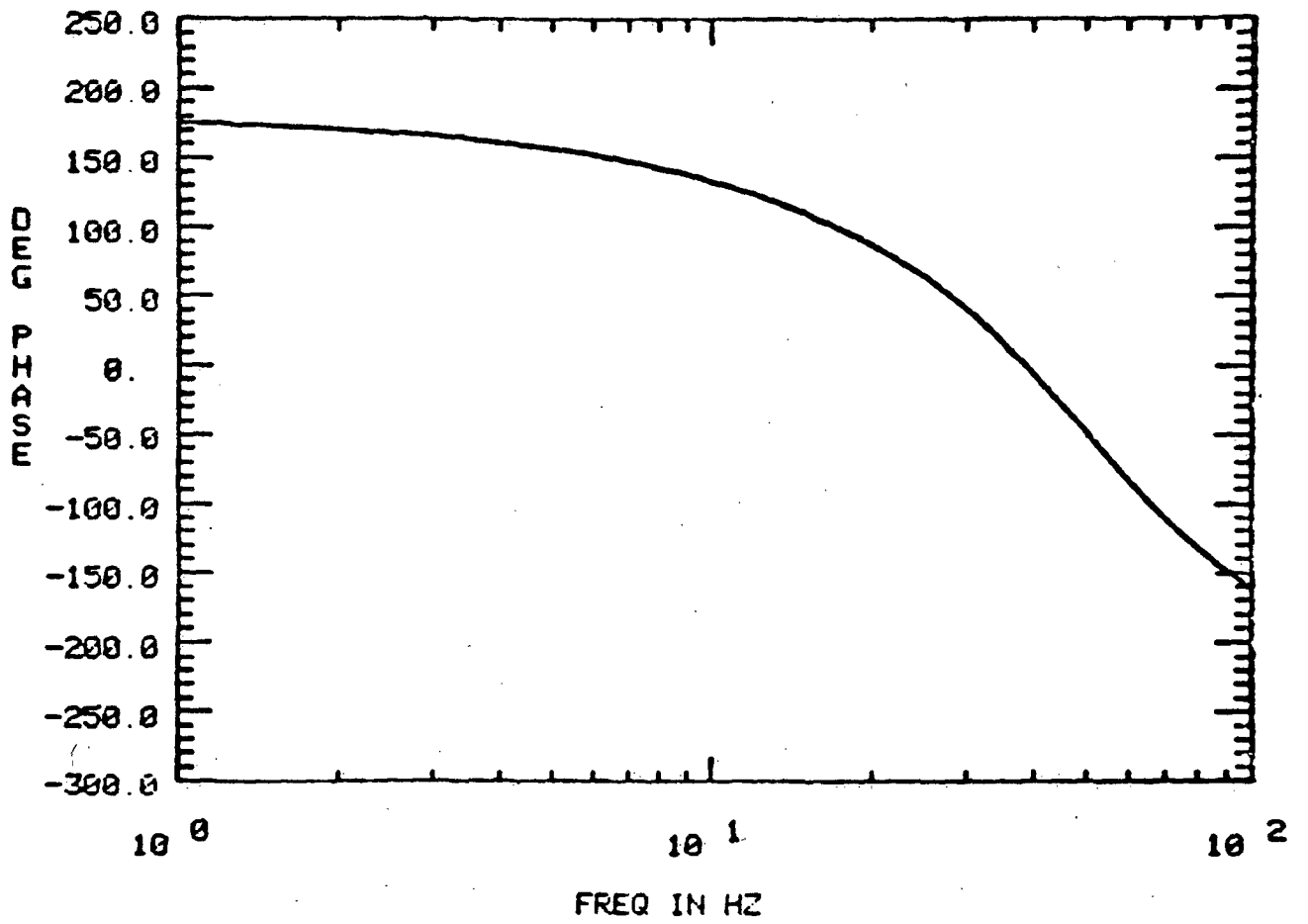

FIGURE 4.6 AMPLITUDE RESPONSE OF 5-POLE BUTTERWORTH LOWPASS FILTER

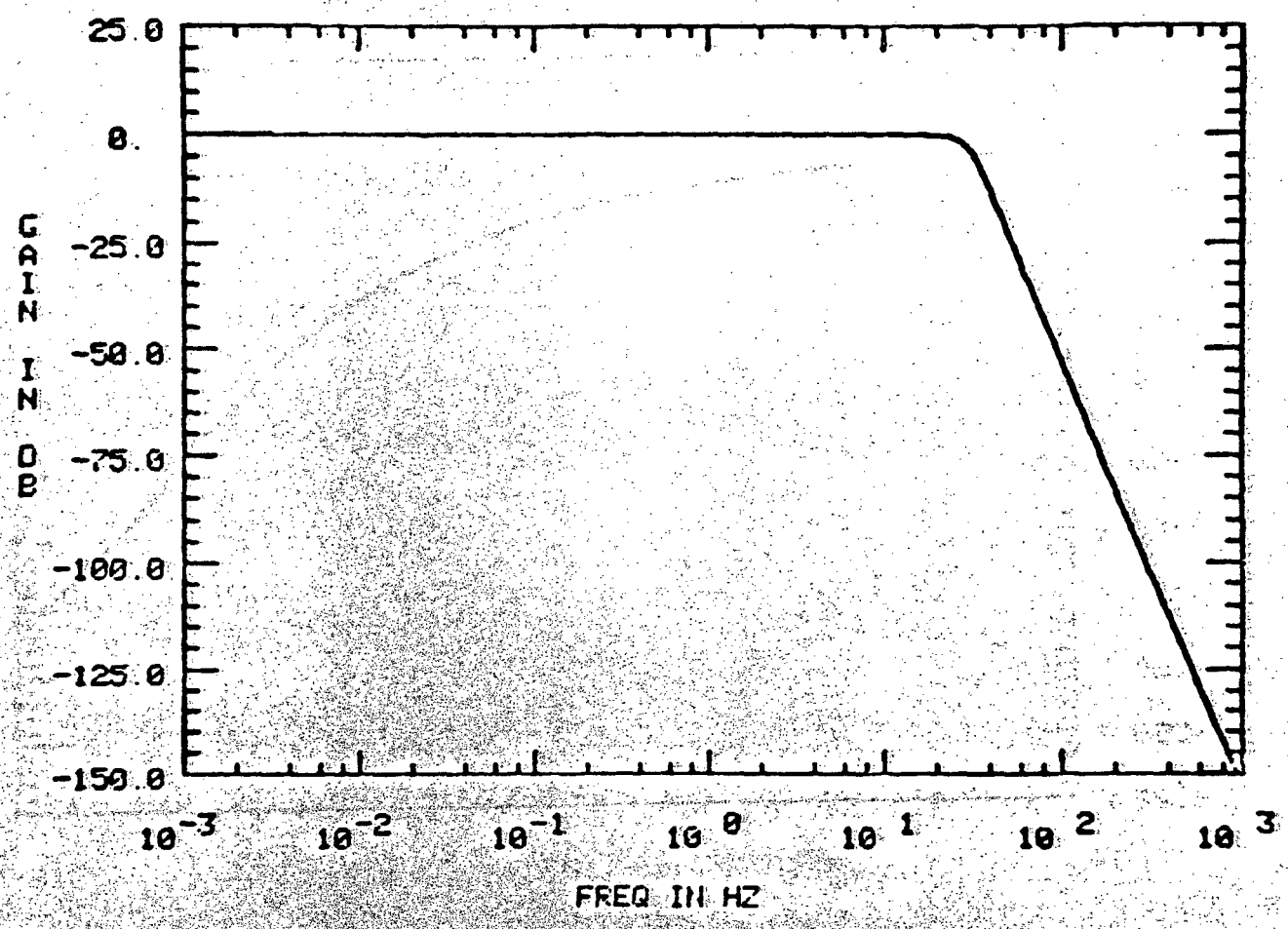

FIGURE 4.7 PHASE RESPONSE OF 5-POLE BUTTERWORTH LOWPASS FILTER

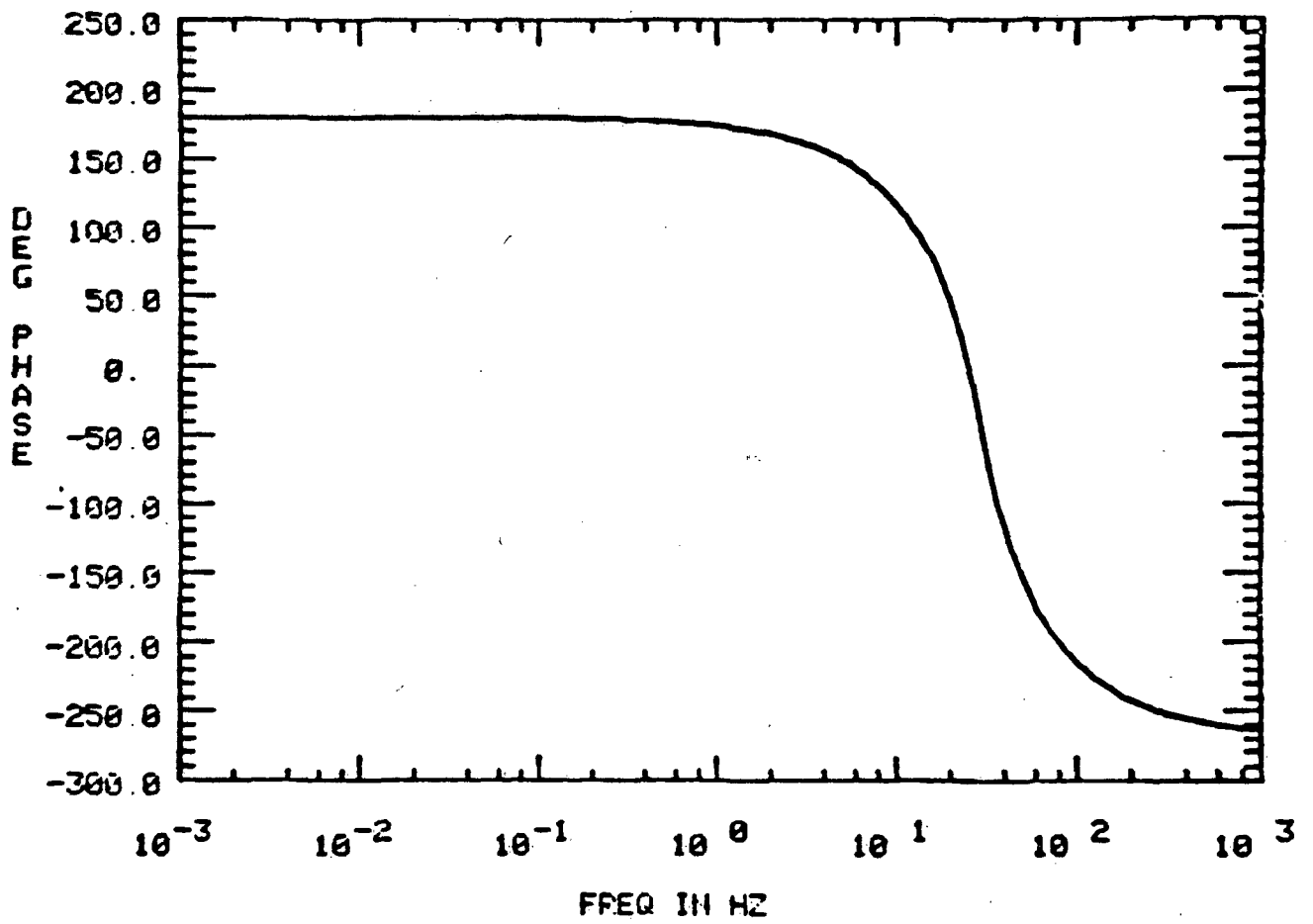

FIGURE 4.8 AMPL. RESP. NEAR CUTOFF OF 5-POLE BUTTERWORTH LOWPASS FILTER

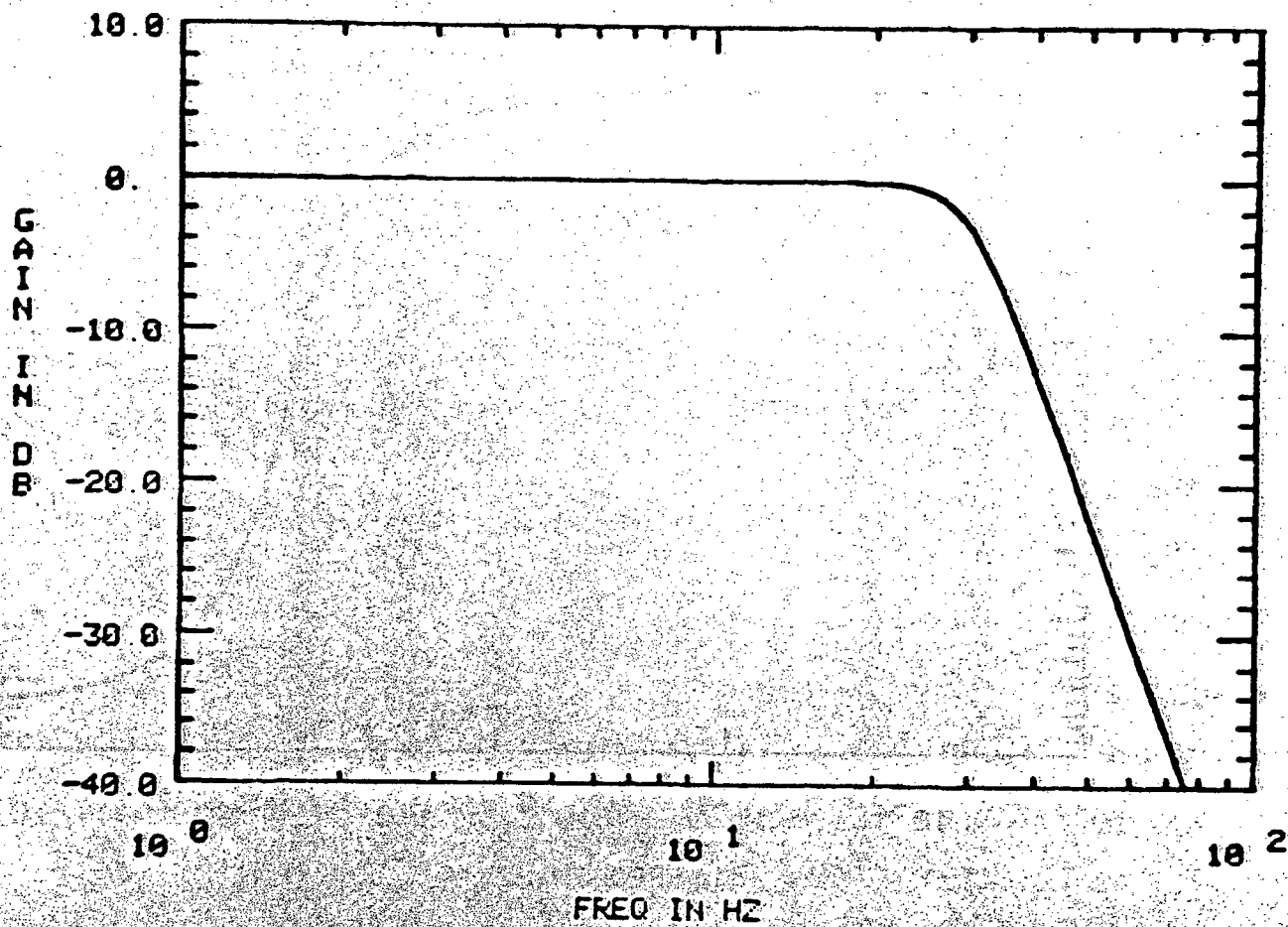
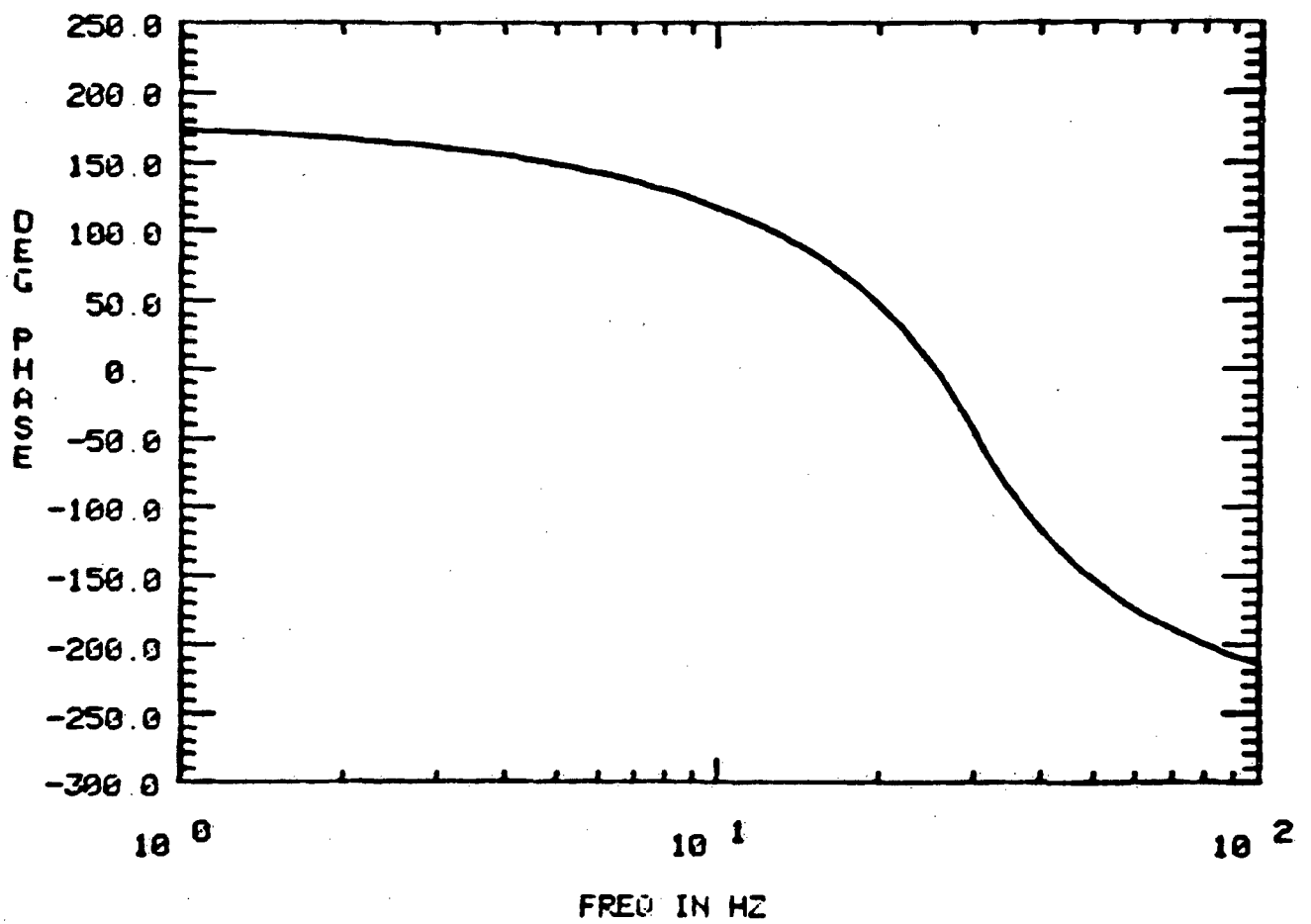

FIGURE 4.9 PHASE RESPONSE NEAR CUTOFF OF 5-POLE BUTTERWORTH LOPASS FIL



5. OVERALL SYSTEM RESPONSE

Under the assumptions and approximations used to derive transfer functions for the individual system components above, the response of the entire system is described by the product of the individual transfer functions. These are: the seismometer response given in equation (2.11), the preamplifier-filter response given in equation (3.16), and the response of the discriminator output filter. Unfortunately, of the four discriminators in use or planned for use, only the Tri-Com model 402 has an output filter whose analytical response function is known at this writing. Thus, the analytical response function for the overall system may be written only for data played back through the Tri-Com discriminators. This function is just the product of the expressions (2.11), (3.16), and (4.2). Expressed in terms of the absolute frequency f , the overall system response is:

$$T_{\text{tot}}(f) = T_s(f) \cdot T(f) \cdot T_f(f) = \frac{-A_{\text{tot}} f^5 (1 + if/f_3)}{(1 - f^2/f_0^2) + \frac{2i\delta f}{f_0}} \prod_{k=1}^{10} \frac{1}{1 + if/f_k} \quad (5.1)$$

where

$$A_{\text{tot}} \text{ is total system gain} = \frac{2\pi G_{\text{eff}} \text{GB}}{f_0^2 f_2 f_5};$$

f_0 is natural frequency of the seismometer in Hz; δ is the damping factor of the seismometer; f_3 is the zero in the J302 response in Hz given in (3.16); f_1, f_2, f_4, f_5 are the poles in the J302 response in Hz as given in (3.16); $f_6 - f_{10}$ are the complex characteristic frequencies of the Tri-Com 402 output filter, expressed in terms of absolute frequency f in Hz as in expression (4.2); G_{eff} is the effective generator constant of the seismometer, from equation (2.8), in V/m/sec; G is the gain of the J302, expressed as an amplitude ratio as in Table 3.2; and B is a telemetry fudge-factor, explained below.

With the proper substitutions, the function $T_{tot}(f)$ gives the voltage response at the output of the discriminator to sinusoidal ground displacement at the seismometer at frequency f . Except for B , all the constants and instrument parameters are discussed above. Pole positions $f_1, f_2, f_4, f_5 - f_{10}$ are given in sections 3 and 4, and the position f_3 of the zero in the J302 response is derived in section 3. For convenience, these parameters, as well as typical values of β, G_{eff}, f_0 , and the seismometer circuit resistances R_c, S , and T , which depend on the particular seismometer and L-pad under consideration, are shown in Table 5.1. Normally, R_A is set to $10K\Omega$ by circuit design and $B = 0.593$.

Both the VCO and discriminator have adjustable sensitivities, and these are normally set as follows: VCO sensitivity = ± 125 Hz/ ± 3.375 volts, and discriminator sensitivity = ± 2 volts/ ± 125 Hz (with unity speedup factor). However, sensitivities can drift or be misadjusted, discriminators with different output ranges can be used, and output ranges can be altered for technical reasons. Therefore, the "fudge-factor" B is included as a reminder that the voltage gain of the particular VCO-discriminator pair used in a system must be taken into account. If $\pm V_{VCO}$ change at the VCO input produces ± 125 Hz deviation from center frequency and $(\pm 125 \text{ Hz}) \times (\text{speedup factor})$ produces $\pm V_{DISC}$ at the discriminator output, B is simply given by

$$B = V_{DISC}/V_{VCO} = 2/3.375 = 0.593 \quad (5.2)$$

It is interesting to note that, as long as the discriminator output filter has a response of the form (4.2), the overall system response (5.1) can be written as a product of poles and zeroes. This can be done simply by finding the complex roots of the denominator in the seismometer response (2.11). If the ratio f/f_0 is defined as X , the poles of $T_g(f)$ are just the zeroes of

TABLE 5.1 SYSTEM RESPONSE PARAMETERS

| Characteristic Frequency | Expression | Figure for Reference | Value (Hz) |
|--------------------------|---|----------------------|----------------|
| f_1 | $[2\pi(R3)(C2)]^{-1}$ | 3.1 | 48.4 |
| f_2 | $[2\pi(R8)(C3)C]^{-1}$ | 3.1 (Note 1) | .096 |
| f_3 | $[2\pi \frac{(R10)(R9)}{R10 + R9} C4]^{-1}$ | 3.1 | 6,180. |
| f_4 | $[2\pi(R10)(C4)]^{-1}$ | 3.1 | 49.8 |
| f_5 | $[2\pi(R14+R15)C5]^{-1}$ | 3.1 | .085 |
| f_6 | $-(30\text{Hz})\tilde{S}_6 = +30\text{Hz}(1.5023)$ | | 45.07 |
| f_7 | $-(30\text{Hz})\tilde{S}_7 = +30\text{Hz}(1.3808 - 10.7179)$ | | 41.42 - 121.54 |
| f_8 | (Note 2) $-(30\text{Hz})\tilde{S}_8 = +30\text{Hz}(1.3808 + 10.7179)$ | | 41.42 + 121.54 |
| f_9 | $-(30\text{Hz})\tilde{S}_9 = +30\text{Hz}(0.9576 - 11.4711)$ | | 28.73 - 144.13 |
| f_{10} | $-(30\text{Hz})\tilde{S}_{10} = +30\text{Hz}(0.9576 + 11.4711)$ | | 28.73 + 144.13 |

TABLE 5.1 SYSTEM RESPONSE PARAMETERS (CONT)

SEISMOMETER PARAMETERS

(TYPICAL VALUES FOR STATION BGG AS OF 8/14/75)

| Parameter | Symbol | Typical Value | Units |
|--|-----------|-----------------------------|-----------------------|
| Mass | m | 1.00 | Kilogram |
| Natural Frequency | f_o | 1.044 | Hz |
| Coil resistance | R_c | 5.35 | Kilohm |
| Series pad resistance | T | 2.118 | Kilohm |
| Shunt pad resistance | S | 6.749 | Kilohm |
| Amplifier input resistance | R_A | 10.0 | Kilohm |
| Damping factor | B | 0.798 (Note 3) | No units |
| Seismometer Generator Constant | G_L | 285. | V/(m/sec) |
| Effective Generator Constant | G_{eff} | 100. (Note 4) | V/(m/sec) |
| System gain (for $A_{sta} = 12db$) | A_{tot} | 3.56×10^8 (Note 5) | V-sec ⁵ /m |

TABLE 5.1 SYSTEM RESPONSE PARAMETERS (CONT)

Notes:

1. Changes slightly with attenuator setting -- see Table 3.1.
2. Calculated for the Bessel filter using the pole positions $\tilde{S}_6, \dots, \tilde{S}_{10}$ supplied by the manufacturer and shown in Equation 4.3. Frequencies for the Butterworth filter may be calculated using the manufacturer's pole positions in Equation 4.4 and the equation $f_k = -\tilde{S}_k f_c = -(30 \text{ Hz}) \tilde{S}_k$.
3. Calculated from equations (2.13) and (2.18) using measured value of β_0 .
4. Calculated from equation (2.8).
5. Calculated from equation (5.1) using above values, G from Table 3.2 for $A_{sta} = 12 \text{ db}$, and $B = 0.593$.

$$1 - X^2 + 2i\beta X = 0 \text{ or } X^2 - 1 - 2i\beta X = 0 \quad (5.3)$$

Using the quadratic formula, the roots are found to be

$$X = \frac{2i\beta \pm \sqrt{-4\beta^2 + 4}}{2} = i\beta \pm \sqrt{1 - \beta^2} \quad (5.4)$$

To insure that the poles in the seismometer response have the same form as the other poles in equation (5.1), let the seismometer pole frequencies f_{11} and f_{12} be defined as follows:

$$X_{11} \equiv \frac{if_{11}}{f_0} \equiv i\beta + \sqrt{1 - \beta^2} \quad (5.5)$$

$$X_{12} \equiv \frac{if_{12}}{f_0} \equiv i\beta - \sqrt{1 - \beta^2}$$

$$\text{or } f_{11} \equiv f_0(\beta - i\sqrt{1 - \beta^2}) \text{ and } f_{12} \equiv f_0(\beta + i\sqrt{1 - \beta^2})$$

With these definitions, the singular part of the seismometer response can be written

$$\frac{1}{1 - f^2/f_0^2 + 2i\beta f/f_0} = \frac{f_0^2/f_{11}f_{12}}{(1 + if/f_{11})(1 + if/f_{12})} \quad (5.6)$$

$$= \frac{1}{(1 + if/f_{11})(1 + if/f_{12})}$$

as the product $f_{11}f_{12} = f_0^2$ by equation (5.5).

Substitution of (5.6) into (5.1) yields an expression for the overall transfer function as a product of simple zeroes and simple poles:

$$T_{\text{tot}}(f) = -A_{\text{tot}} if^5 (1 + if/f_3) \prod_{\substack{k=1 \\ k \neq 3}}^{12} \frac{1}{1 + if/f_k} \quad (5.7)$$

Here, the system gain A_{tot} is given in (5.1) and the product of poles has been extended to include the seismometer poles f_{11} and f_{12} . For convenience, Table 5.2 lists typical values of the absolute frequencies

TABLE 5.2 CHARACTERISTIC FREQUENCIES OF THE SYSTEM

| Frequency f_k | Value (Hz) | Corresponding Pole Position $S_k = -2\pi f_k(1/\text{sec})$ (no scaling frequency) |
|--------------------|-------------------------|--|
| f_0 | 1.044 (Note 1) | ----- |
| f_1 | 48.4 | -304.1 |
| f_2 | 0.096 (Note 2) | -0.603 |
| f_3 | 6,180. | -38,830. |
| f_4 | 49.8 | -312.9 |
| f_5 | 0.085 | -0.534 |
| f_6 | 45.07 | -283.2 |
| f_7 | 41.42 - 121.54 | -260.2 + 1135.3 |
| f_8 | 41.42 + 121.54 | -260.2 - 1135.3 |
| f_9 | 28.73 - 144.13 | -180.5 + 1277.3 |
| f_{10} | 28.73 + 144.13 | -180.5 - 1277.3 |
| f_{11} | 0.833 - 10.629 (Note 3) | -5.234 + 13.952 |
| f_{12} | 0.833 + 10.629 (Note 3) | -5.234 - 13.952 |

NOTES:

1. Typical value: actual value for station BGG as of 3/14/75.
2. Changes slightly with attenuator setting (see Table 3.1 and Equation 3.16).
Correction ignored here.
3. Calculated from equations (5.5) using value of f_0 above and value of β from Table 5.1.

$f_1 - f_{12}$ of the poles and the zero. Note that all have positive real parts, and that those for the seismometer and discriminator output filter are complex.

In circuit analysis, it is more usual to express the pole and zero positions in terms of the complex variable S , where S is defined by

$$S \equiv i\omega \equiv 2\pi f \quad (\text{see note on p. 41a}) \quad (5.8)$$

To effect a transformation to the S -plane, complex S -pole positions are defined as follows:

$$S_n = -2\pi f_n$$

so that

$$\frac{1}{1 + if/f_n} = \frac{f_n}{f_n + if} = \frac{-(-2\pi f_n)}{-(-2\pi f_n) + 2\pi if} = \frac{-S_n}{S - S_n} \quad (5.9)$$

For a single circuit, S is usually scaled by some characteristic frequency f_c , e.g., the cutoff frequency of the discriminator output filter, so that S is defined as $S = 2\pi if/f_c$. Here, however, as each part of the system transfer function has its own characteristic frequency, no scaling factor is used.

If the transformations (5.8) and (5.9) to the complex S -plane are made, the overall system response becomes

$$T_{\text{tot}}(S) = T_{\text{tot}}(2\pi if) \\ = -A'_{\text{tot}} S^5 \frac{(S - S_3)}{S_3} \prod_{\substack{k=1 \\ k \neq 3}}^{12} \frac{S_k}{S - S_k} \quad (5.10)$$

where $A'_{\text{tot}} \equiv \frac{A_{\text{tot}}}{32\pi^5}$

This equation describes the system response at the discriminator output to ground displacement. The responses to ground velocity and ground acceleration are obtained simply by dividing expression (5.10) by S and S^2 , respectively.

Table 5.2 lists typical values of the eleven simple

Note: The complex frequency S and the pole positions S_n are defined differently here than the complex frequency \tilde{S} and the pole positions \tilde{S}_k for the discriminator output (pages 24-25b). Because there is no single frequency that is characteristic of the entire system, no scaling frequency is used in defining S and S_n . Accordingly, in the interactive plotting process, the factor of 2π enters in the relationship between the S_n and the f_n , and a "cutoff frequency" of unity is entered.

poles in the S-plane, $S_1, S_2, S_4, S_5, \dots, S_{12}$, and the simple zero S_3 . Note that all have negative real parts, as is required for a stable active system.

A word about units is in order here. The most convenient system of units for seismometer calibration is the MKS, or practical system, whose fundamental units are the meter, the kilogram, the second, and the coulomb. Electrical units are then the volt, the ampere, and the ohm. Some caution must be exercised in using this system, however, since seismometer manufacturers may express certain quantities in mixed units. For instance, mixed units of $V/(cm/sec)$ are often used for the seismometer generator constant G_L . To convert to the practical system, i.e., units of $V/(m/sec)$, the value of G_L in mixed units must be multiplied by 100.

To illustrate the practicality of the MKS system, the units of equations (5.1) and (2.18) will be investigated. In the following expressions, the symbols $[A] = Kg$ should be read "the quantity A has units of kilograms". Examinations of equations (2.8) and (3.16) and (5.2) show that

$$\begin{aligned} [G_{eff}] &= [G_L] = V/(m/sec) \\ [G] &= \text{no units} \\ [f_0] &= [f_2] = [f_5] = 1/sec \\ [\beta] &= \text{no units} \end{aligned} \tag{5.11}$$

Hence

$$[A_{tot}] = \frac{[G_{eff}][G][\beta]}{[f_0]^2[f_2][f_5]} = \frac{V/(m/sec)}{(1/sec)^4} = \frac{V \cdot sec^5}{m} \tag{5.12}$$

Now, inspection of the expression for T_{tot} shows that

$$[T_{tot}] = [A_{tot}] [f]^5 = \frac{V \cdot sec^5}{m} \frac{1}{sec^5} = \frac{V}{m} \tag{5.13}$$

Thus, the units of the voltage response to displacement A_{tot} are volts/meter, as expected.

Derivation of units for equation 2.18 proceeds as follows. According to that equation,

$$\beta_1 = \frac{G_L^2}{2m_o R_{eff}} \quad (5.14)$$

so

$$[\beta_1] = \frac{[G_L]^2}{[m][\omega_o][R_{eff}]} = \frac{[V/(m/sec)]^2}{Kg \cdot \frac{1}{sec} \cdot ohm} = \frac{V^2 \cdot sec^3}{Kg \cdot m^2 \cdot ohm}$$

To eliminate the electrical quantities, the well-known expression for the power P dissipated by a voltage V applied across a resistance R is used:

$$P = V^2/R$$

hence

$$\frac{V^2}{ohm} = \left[\frac{V^2}{R} \right] = [P] = \text{Watt} = \frac{Kg \cdot m^2}{sec^2} \cdot \frac{1}{sec} \quad (5.15)$$

With this substitution, (5.13) becomes,

$$[\beta_1] = \frac{V^2}{ohm} \cdot \frac{sec^3}{Kg \cdot m^2} = \text{no units} \quad (5.16)$$

So that the resistive part β_1 of the damping factor β is dimensionless, as expected. As long as MKS units are used, derivation and verification of dimensions for seismographic quantities is straightforward.

Equations (5.1) and (5.10) give the overall system response for stations in the central California network, provided that the Tri-Com 402 discriminator is used to play back the data. The form of equation (5.10) is directly compatible with the programming machinery, discussed in the next section, for generating interactively computer plots of transfer functions. Figures 5.1-5.4 show, respectively, the amplitude and phase response of the system to ground displacement and ground acceleration. Values of the instrument parameters used are the typical ones in Table 5.1, and the transfer function subroutine TRFUN used to generate the plots of displacement response is listed in Table 5.3.

FIGURE 5.1 AMPLITUDE OF SYSTEM RESPONSE TO DISPLACEMENT

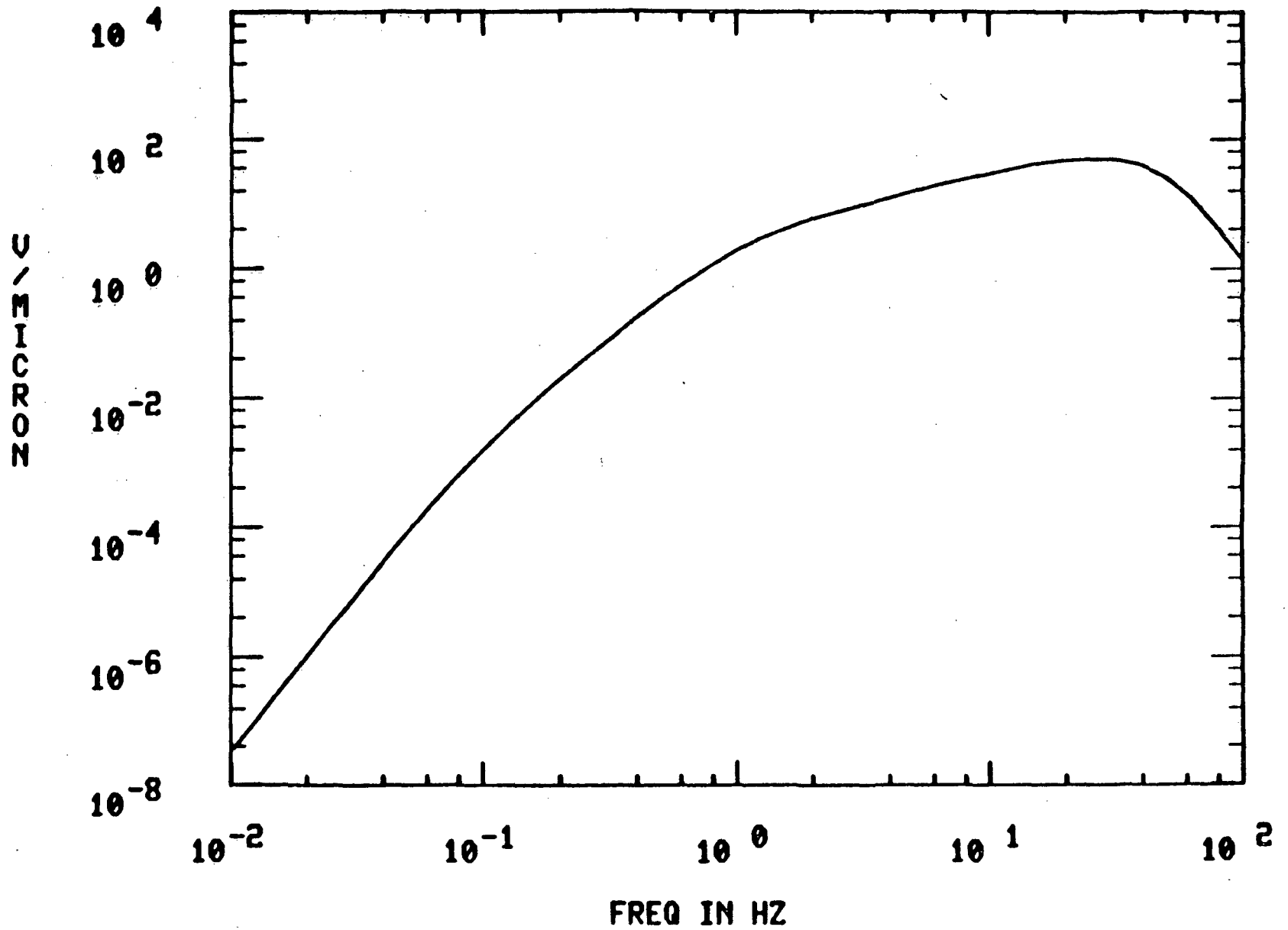

77

FIGURE 5.2 PHASE OF SYSTEM RESPONSE TO DISPLACEMENT

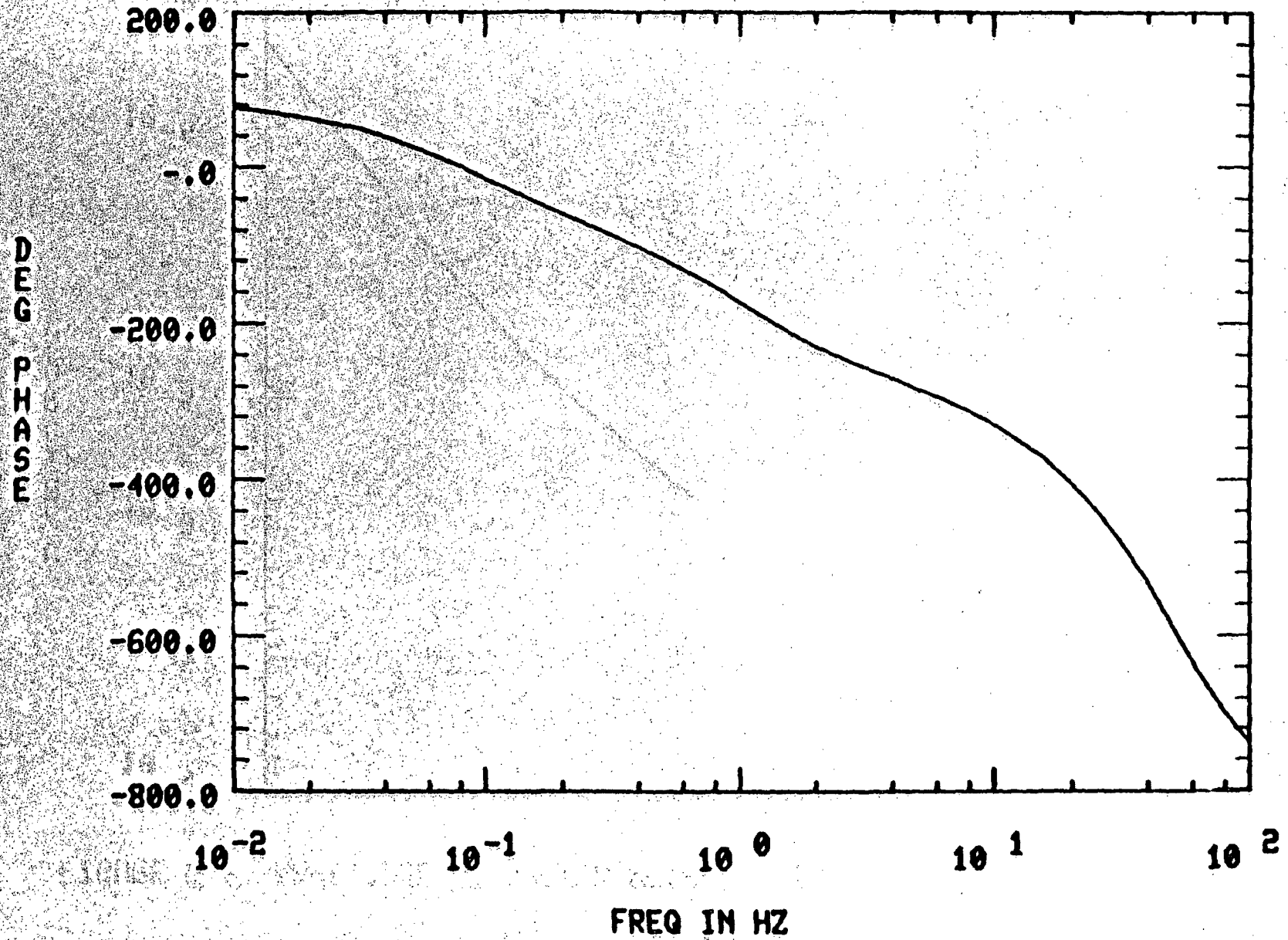

45

FIGURE 5.3 AMPLITUDE OF SYSTEM RESP. TO ACCELERATION IN V/(MIC/SEC**2)

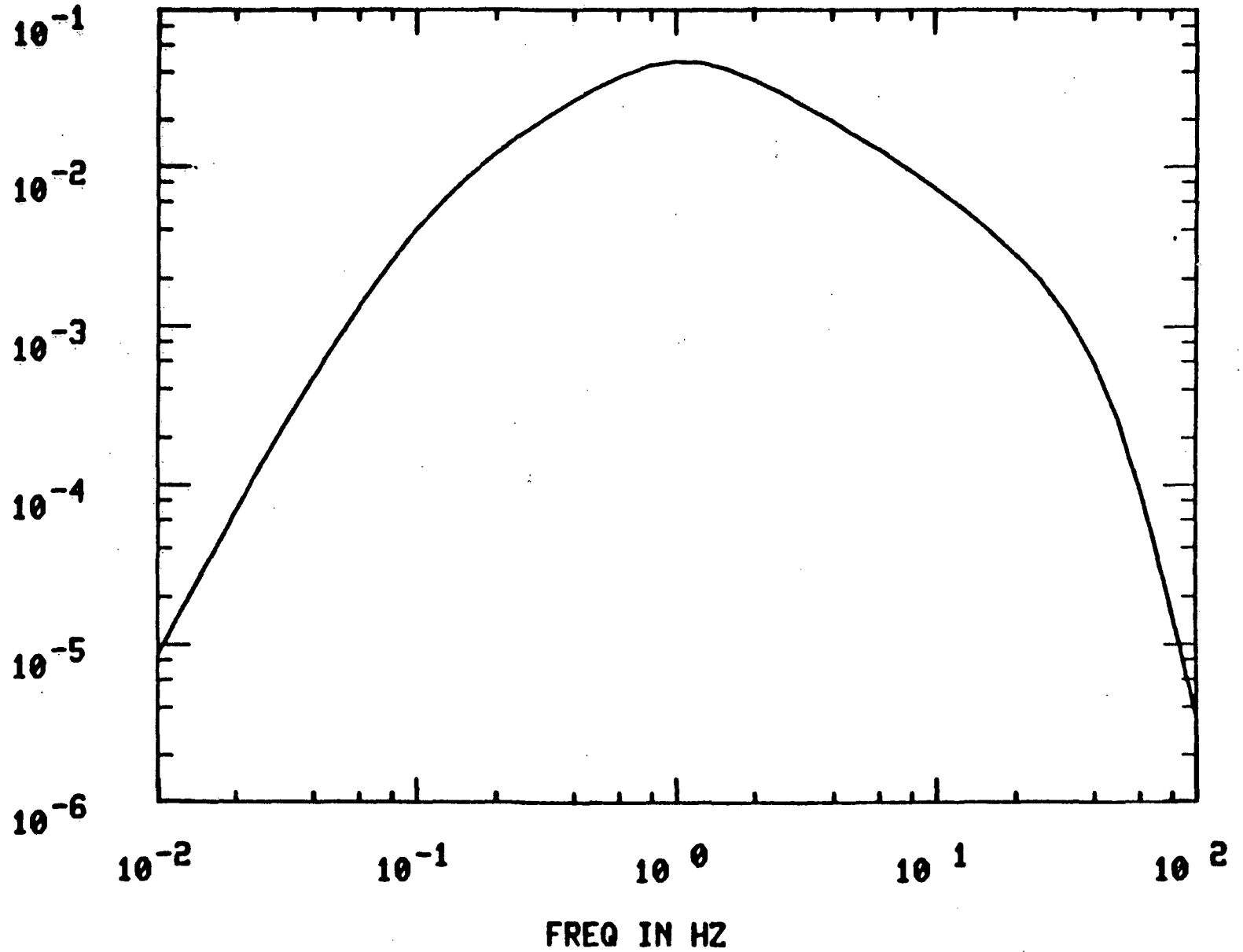
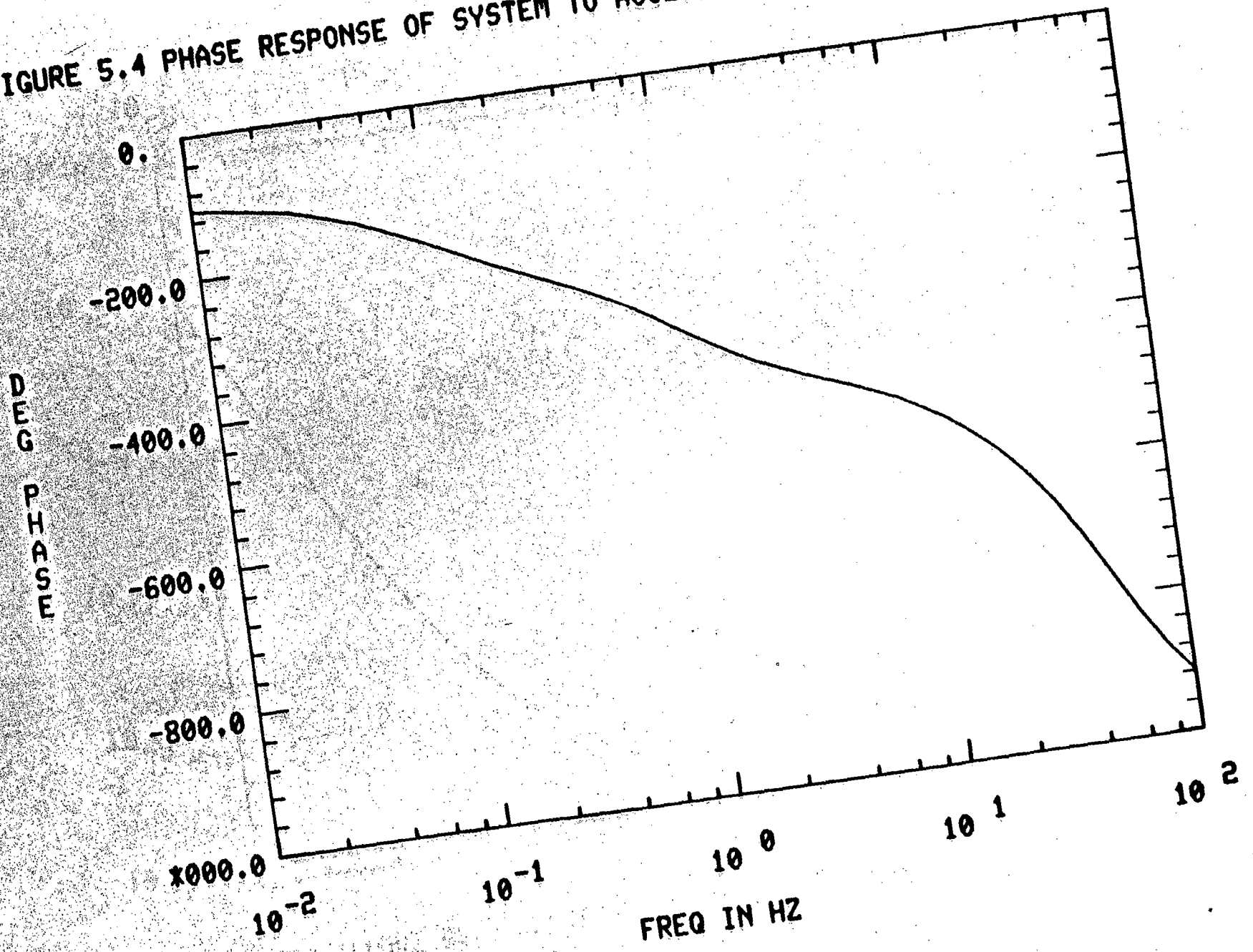

FIGURE 5.4 PHASE RESPONSE OF SYSTEM TO ACCELERATION



47

TABLE 5.3 SUBROUTINE TRFUN USED TO COMPUTE OVERALL SYSTEM RESPONSE

P 30

```

SUBROUTINE TRFUN(S,T)
COMPLEX S,T,J,P(12)
PI=3.141592653 $ J=(0.,1.)
N=12
ATOT=3.53E02
S=S*2.*PI
P(1)=(-304.1,0.)
P(2)=(-0.603,0.)
P(3)=(-38830.,0.)
P(4)=(-312.9,0.)
P(5)=(-0.534,0.)
P(6)=(-283.2,0.)
P(7)=(-260.2,135.3)
P(8)=(-260.2,-135.3)
P(9)=(-180.5,277.3)
P(10)=(-180.5,-277.3)
P(11)=(-5.234,3.953)
P(12)=(-5.234,-3.953)
ATOTP=ATOT/32./PI**5
(*) T=ATOTP*S**3*(S-P(3))/P(3)
DO 10 I=1,N
IF(I.EQ.3)GO TO 10
T=T*P(I)/(S-P(I))
10 CONTINUE
RETURN
END
(BOTTOM OF FILE)

```

NOTES:

1. This computes acceleration response. For displacement response, change exponent in line (*) from 3 to 5.

2. Input frequencies S are already scaled by "cutoff frequency" FC in main program, so that S is passed to this subroutine as $S=J*F/FC$. See page 63, line 127.

Theoretical transfer functions (5.1) and (5.10) and the plots derived from them represent compromises between ease of calculation and accuracy of the description. They are approximations based on the assumptions of 1) linearity of the mass-spring system in the seismometer, 2) linearity of the coil-magnet transducer, 3) constancy of the seismometer parameters, especially the spring and magnet strengths, 4) low tolerances for electronic components in the J302 preamplifier, 5) no loading of the attenuator and highpass filter in the preamplifier, and 6) use of the Tri-Com 402 discriminator to reproduce the data. The first three assumptions are natural and indispensable for the derivation of simple and useful response functions, and they are generally good approximations. The fourth may be more or less true depending upon the particular station and model numbers of the electronic units used in it. With component tolerances of 5%, the accuracy of the calculated response at any frequency is probably no better than 20%. With components of 1% tolerance, 5 to 10% accuracy in the response is possible. The approximations involved in assumption 5 are avoidable if corrections in the actual attenuation and the highpass filter cutoff frequency f_2 are made as discussed in section 3. These corrections depend on the "station attenuator setting" A_{sta} and are important only at settings near the highest J302 gain of 90db. Finally, the present results may be used as guides to the system response when discriminators other than the Tri-Com 402 are used, but possible differences in the output filter response should be borne in mind. Such differences can be expected to have little effect on the amplitude of the response below the cutoff frequency of the output filter. However, with certain discriminators, the phase response may differ significantly from that derived here even well below the cutoff frequency.

6. Interactive Routines for Plotting Transfer Functions

This section of the report is used to document a computer program for interactive plotting of the amplitude and phase of arbitrary complex-valued transfer functions on the Tektronix 4010 or 4014 CRT. Plot titles, range of the ordinate, frequency range, and resolution are entered by the user, while the form of the transfer function is determined by Fortran code in a subroutine. The routines use the computer facilities of the Lawrence Berkeley Laboratory and require the systems graphics routines available there. Although the program was designed to obtain plots of the network response functions in this report, it is applicable to any complex-valued response function of a single complex variable.

In the following paragraphs, the operation and structure of the program is outlined. To use this program, only a rudimentary knowledge of Fortran programming and the ability to log onto the Berkeley system are required. No knowledge of the control system at Berkeley is necessary.

Program Operation

The plotting program, along with the control cards needed to attach the system routines and run under control of the Berkeley SESAME system, is stored in subset JAY of library DAUL. In case these subsets are destroyed, the program and control cards are preserved on a source deck kept by Bill Bakun.

There are four steps required to run the program:

1. Log onto the Berkeley system, on the 6600B or 6400C machine.
2. Execute the SESAME commands LIBCOPY, DAUL, JAY, JAY.

DISPOSE, JAY = IN.

3. Alter the subroutine TRFUN on the local file JAY to calculate the desired transfer function.
4. Execute the SESAME command CALL JAY. Thereafter, the program will request the necessary information for the plots as explained below.

The techniques for logging on the system are simple and can be learned quickly from any user. Except for step 3, the other steps are self-explanatory. Changing the subroutine TRFUN requires the following information about the NETED editing system used at Berkeley:

1. To begin editing the local file JAY, type NETED JAY (return).
2. The NETED editor uses an imaginary "pointer," which locates the line being edited or the position in the file from which or to which editing will be done. If the pointer is at line n, then typing
 - N 5 (return) moves it to line n+5
 - N-3 (return) moves it to line n-3
 - T (return) puts it just before the first line
 - B (return) puts it just after the last line
 - L GORP (return) puts it at the first line after line n that contains the string GORP

None of these commands changes the text, and none produces any output except the messages "(TOP OF FILE)" or "(BOTTOM OF FILE)" as appropriate.

3. If the pointer is at line n, then typing

P 6 (return) prints lines n through n+5, inclusive, and moves the pointer to line n+5

This command does not change the text.

4. Changes are made by deleting, inserting, or changing lines as follows:

DTOP (return) deletes all lines from the first line up to (but not including) line n

D (return) deletes line n only

D 5 (return) deletes five lines beginning with line n

I GORP (return) inserts after line n a line consisting of the string GORP, and leaves all preexisting lines unchanged

C /OLD/NEW/ (return) replaces the first occurrence of the string OLD in line n with the string NEW. The delimiter / may be replaced by any character that does not appear in either string.

5. Typing . (return) puts the editor into an input mode, in which all further input until the next line beginning . (return) is written on the file being edited. Input begins after the pointer position at the time the input mode is entered.

6. To change the transfer function subroutine on file JAY, type L
SUBROUTINE TRFUN (return), wait for output, then type . (return) and input the body of the new subroutine, remembering that Fortran commands begin with character number seven. After the END card, type . (return), wait for output, and then type D 300 (return) to delete anything remaining after the new subroutine.

7. When editing is complete, typing W JAY (return) replaces the local file JAY with the edited version. Typing QUIT (return) at any time exits from the editor.

8. All NETED letter commands require a space between the command letter and any argument to the command that does not count as part of the argument.

9. Typing ? (return) while in NETED produces a brief list of NETED commands, not all of which are discussed here.

For reference, a listing of subset JAY of library DAUL (formerly subset TRFPLT of library JDRAT) is supplied as Appendix A. Two different versions of the subroutine TRFUN appear at the end of the subset. The first calculates the response (4.2) of a 5-pole Bessel lowpass filter with the poles given in equations (4.3), while the second calculates the response of a 5-pole Butterworth lowpass filter using the poles in (4.4). Since the Berkeley system loads only the first of multiple subroutines with the same name, subset TRFPLT as stored will plot the Bessel response. To plot another function, the user may 1) insert a new subroutine TRFUN ahead of the two existing ones, or 2) modify the first of the two current TRFUN routines. Within a new subroutine the independent variable S and the function value T must be declared

COMPLEX, and the user may wish to define the unit imaginary number J and the constant PI as shown.

In the main program, the variable S used by TRFUN is defined as $S=if/f_c$, where f is the absolute frequency in Hz and f_c is a scaling frequency in Hz entered by the user during the interaction. For plots of non-scaled transfer functions of $S=i\omega=2\pi if$, the user may enter $f_c = 1/2\pi = .15915494$. Alternatively, the user may add the Fortran statement $S=S*2*PI$ before the statements calculating his transfer function and enter 1.0 as the cutoff frequency during the interaction.

The interaction proceeds as follows:

A. ENTER PLOT TITLE. A single line of up to 80 characters, entered by the user, will appear as the title of the subsequent plot unless changed.

B. ENTER EXPONENTS OF LOWER AND UPPER FREQS IN HZ. Two integers, separated by a comma, blank, or letter, are the exponents of the frequency limits for the next plot. For example, the entry -4, 6 would produce a plot of $T(S=if/f_c)$ from $f=10^{-4}$ Hz to $f=10^6$ Hz.

C. ENTER CUTOFF FREQUENCY IN HZ. The user enters the scaling frequency f_c as a fixed point number in Hz.

D. The program calculates the amplitude in decibels and the phase in degrees of T(S) as $GAIN = 20*ALOG10(CABS(T))$ and $PH=180/PI*ATAN2(AIMAG(T), REAL(T))$ over the frequency range selected with a resolution of 10 plotted points per decade of frequency. If the phase does not vary too rapidly between points, the program adds or subtracts multiples of 360° when necessary to make the phase a continuous function of frequency.

E. WHAT NEXT?

1 = NEW TITLE 2 = NEW FREQS 3 = NEW LIMITS 4 = NEW RESLTN 5 = PLOT GAIN
6 = PLOT PHASE 7 = STOP 8 = NULL 9 = NULL

The user enters his choice. Options 1 and 2 return the user to step A or to step B followed by C, respectively. The NEW LIMITS option allows the user to enter the minimum, then maximum ordinate in decibels or degrees for subsequent plots. If this option is not used, the program will calculate ordinate limits for subsequent plots. The NEW RESLTN option allows the user to ENTER NEW NUMBER OF POINTS PER DECADE to be calculated and plotted, with the restriction that the total number of points plotted, i.e., (the number of points per decade) X (the number of decades) +1, must be less than 200. Normally, the default resolution of 10 is sufficient for most purposes. The other options are self-explanatory, except that options 8 and 9, as well as 7, terminate the program and return the user to the Berkeley SESAME system. To restart the program, the user must type CALL JAY (return) again. After each plot, the program returns to step A, and the user is forced to enter a new title, new frequency limits, and a new cutoff frequency.

Ordinarily, the user will use the default resolution of 10 points per decade and allow the program to calculate the lower and upper ordinate values for the first plot. Thereafter, with the options in step E, the user may adjust and repeat the plot indefinitely until he is satisfied with its appearance. Since the program involves only simple computations and requires little CPU time, the user need have no qualms about repetitive interaction to perfect the plots.

IMPORTANT NOTE: After each plot, the user is required to enter any digit followed by a carriage return before the program will continue. This allows time for making a copy of the CRT screen.

Subroutine Documentation

In order to facilitate rapid development of the program and permit swift changes, comment cards are not included in the code. The following brief description of the program and its subroutines is offered as an aid to users who may wish to modify the program. The routines are listed in the order in which they appear on subset TRFPLT as shown in Appendix A.

PROGRAM CALTRF. The main program: sets the file environment table (FET) for the teletype, here TAPE1; initializes the plot size on the screen by setting TVXMIN, ..., TVXMAX; initializes program variables and flags; allows interactive entry of plot variables; sets up and sends the plot to the teletype; requests a dummy numeric input by the statement CALL GET(R) to allow for hard copying of the plot; and, returns control to the option subroutine WHTNXT.

Important variables are as follows:

TVXMIN, TVXMAX, TVYMIN, TVYMAX = boundaries of plot as fraction of screen size.

NST = exponent of minimum frequency (in Hz) for plot.

NEND = exponent of maximum frequency (in Hz) for plot

FC = cutoff frequency in Hz

LIMFLG = flags user entry of ordinate limits, is zero if limits are to be calculated, 1 if limits are entered by user.

LFIRST = 0 for first plot in sequence (step A above) and = 1 at step E.

NRES = plot resolution, or number of points calculated per decade variation in f.

Common blocks:

/TVPOOL/ and /TVTUNE/ are required for operation of the systems graphics routines as explained in subset TV of library WRITEUPS

/JPLOT/ = left, right, upper, and lower limits of plot, expressed in data coordinates

/TRF/ = arrays to be plotted: log of the frequency in Hz, response amplitude in DB, phase in degrees.

The subroutines TVNEXT, TVLTR, TVPLOT, and TVSEND are systems routines explained in subset TV of library WRITEUPS.

SUBROUTINE WHTNXT(N). This routine writes the list of options in step E on the CRT screen and allows the user to enter the number N of the option chosen.

SUBROUTINE GNPHE(NST, NEND, FC). This subroutine calculates the arrays FLOG, GNDB, and PH in common block /TRF/ for frequencies from $f = 10^{\text{NST}}$ to $f = 10^{\text{NEND}}$, with cutoff frequency FC as a parameter. It adds or subtracts multiples of 360° to the phase at each frequency when necessary to make the phase a continuous function of frequency. The number of points NRES calculated per decade is supplied in unlabeled common storage. Important variables are:

NDEC = NEND - NST = number of decades of frequency calculated

NPT = NDEC * NRES + 1 = number of points calculated.

NWRAP = number of multiples of 360° to be added to the phase

at each point to make the phase a continuous function of frequency.

L1 and L2 are flags indicating the quadrants of the previous and present value of the phase, before addition of $\text{NWRAP} * 360$. The values of L1 and L2 are: 0 in quadrants I and IV, +1 in quadrant II, -1 in quadrant III, and +2 for phases of $\pm 180^\circ$. By comparing L1 and L2, the routine determines whether the phase angle has crossed the branch cut at 180° and, if so, in what direction; then NWRAP is incremented accordingly.

SUBROUTINE SETPLT(A,N,MAJR,PMAX,PMIN). This routine calculates plot limits PMAX and PMIN for N points of the array A in round numbers. PMAX and PMIN are the upper and lower data limits for the appropriate axis, and MAJR is the number of major divisions to be drawn on the axis. To find the limits, the largest absolute value TMAX of the first N points of array A is found by taking the larger of the absolute values of the minimum and maximum. Next, a round number

RMAX greater than TMAX is found using the subroutine RND (see below). Along with the value RMAX, RND returns a number NT which divides evenly into RMAX. Depending on whether TMAX is derived from the minimum or maximum of the N values in A, RMAX/NT is repeatedly added to or subtracted from RMAX until all N points of A fall within the limits $\pm RMAX$ and $\pm RMAX \mp MAJR * RMAX/NT \pm RMAX/NT/5$. These limits are then returned as PMAX, PMIN (or vice-versa) and MAJR is the number of divisions along the axis, except that MAJR is always made 3 or larger. If the range of the array A is small, e.g., from 1.3 to 1.4, a warning message is sent to the teletype.

SUBROUTINE RND(A, ABIG, MAJR). A round number ABIG close to, but farther from the origin than, the input A and a round integer MAJR less than 10 which divides evenly into ABIG are selected by this routine. The routine takes the absolute value of A, then finds the characteristic part D of the number expressed in scientific notation. From a data array RD of round numbers, the value RD(I) which just exceeds this characteristic is chosen and multiplied by the exponent to the base 10 of A. The round integer is chosen from the companion data array MR.

SUBROUTINE MAXMIN (A, N, BMAX, BMIN) This routine finds the maximum value BMAX and the minimum value BMIN among the first N values of the array A.

SUBROUTINE AXTIC (NAXIS, NBOTH, LINLOG, MAJR, MINR) This routine draws scales on either or both of the axes in a given direction for a rectangular plot. If NAXIS = 1, the tics are along the X-direction; if NAXIS = 2 they are along the Y-direction. Tic marks are made on the axis through the origin only for NBOTH = 1, on the two parallel borders of the plot if NBOTH = 2, and on the axis not passing through the origin if NBOTH = 3. The latter option permits mixed scales, e.g., decibels on the lefthand y-axis and a logarithmic scale on the righthand y axis, to be created with two subroutine calls. If LINLOG = 1, the tics are spaced linearly to mark MAJR major divisions and MINR minor divisions. If LINLOG = 2,

the scale is logarithmic with MAJR cycles, and MINR must be either 5 or 9, corresponding to log cycles 2, 4, 6, 8, 10 and 2, 3, 4, 5, 6, 7, 8, 9, 10, respectively. The total number of divisions per axis is NDIV.

In order to use the same routine for tics in either direction, prefixes A- and B- are used to denote the scaled direction and the other direction respectively. Endpoints of the tics are stored in arrays, with A holding the tic positions along the scaled (A) axis as pairs of equal values, BL holding pairs of lower and higher endpoint positions along the other (B) axis for the (A) axis through the origin, and BU holding pairs of lower and upper endpoint positions along the other (B) axis for the (A) axis not passing through the origin. Calls to the system routine TVPLOT draw the tics as segments between successive pairs of endpoints stored in the arrays.

SUBROUTINE LABNAM(NAXIS, NLET, KNAME) This routine writes titles for the X-axis (NAXIS = 1) or the Y-axis (NAXIS = 2) consisting of NLET \leq 20 letters stored in KNAME. The title is written parallel to the corresponding axis and roughly centered on the plot border. KNAME must be a Hollerith array of dimension at least 2, e.g.

KNAME = 20H THE X-AXIS TITLE IS

SUBROUTINE BORDER. This routine, which has no arguments, draws the rectangular border of the plot using the data limits for the plot stored in common block /JPLOT/.

SUBROUTINE LABAX (NAXIS, LINLOG, MAJR, ALL, ALH) This routine writes a numeric scale for the tic marks along the axis passing the origin. The arguments NAXIS, LINLOG, and MAJR are as in the subroutine AXTIC. Minimum and maximum values of the scale along the A-axis are supplied in ALL and ALH, respectively. If LINLOG = 1, a linear scale from ALL to ALH is written; if LINLOG = 2, ALL and ALH are rounded to integers of at most two digits, and the scale is plotted in the form "10^{ALL}" to "10^{ALH}." As in subroutines AXTIC and LABNAM, the prefix A- denotes the axis

chosen with NAXIS while the prefix B denotes the other axis. For the linear scale, or the exponents in a log scale, the positions of the labels on the screen are adjusted by changing STA and STB. Positions of the 10's in a log scale are set by the constants .02 in BPOS and AST (after statement 50). The use of the systems routine TVLTR is explained in subset TV of library WRITEUPS, and the ENCODE - DECODE statements used in this routine and in LABNAM are discussed in the CDC Fortran manual.

SUBROUTINE GET(R). Written by Jim Herriott, this routine allows format-free entry of up to 10 fixed point numbers or integers. The numbers, which can be separated by any character other than a number or a decimal point, are entered in a line of 70 characters or less and read in Fortran format 7A10. The routine separates the line into the individual numeric values, adjusts the values for sign and position of the decimal point, and stores them in the real array R, which must be dimensioned in the main program. Decimal points need not be used to enter numbers; but, if any number has more than one decimal point, a diagnostic is written on the screen and a new entry is required.

APPENDIX A: LIST OF SUBSET TRFPLT OF LIBRARY JORAT 8/14/75

```

1.30L!
1. DELETE, LGO, LGOB, LISTY.
2. RUN76, C, O=LISTY.
3. LINK, F=LGO, F=TXLGO, B.
4. LGOB, TAPETTY, TAPETTY.
5. CXIT.
6. DELETE, LGOB.
7. LIBCOPY, JORAT, TXLGO/PP, TXLGO.
8. LINK, F=LGO, F=TXLGO, B.
9. LGOB, TAPETTY, TAPETTY.
10. FIN.
11. EOR
12. PROGRAM CALTRF(TAPETTY=201, FILM=201, TAPE1=TAPETTY)
13. COMMON NRES, BLANK(5)
14. COMMON/TUPOOL/XMIN, XMAX, YMIN, YMAX, TUXMIN, TUXMAX, TUYMIN
, TUYMAX
15. COMMON/TUTUNE/ITUNE(30)
16. COMMON/JFLOT/XLT, XRT, YLO, YUP
17. COMMON/TRF/FLOG(500), QHDS(500), PHK 500)
18. DIMENSION IFET(8)
19. DIMENSION KK(3), LINE(7), R(10)
20. *C
21. *C SET FET
22. CALL FET(5LTAPE1, IFET, 8)
23. IFET(2)=IFET(2).OR.0000 0010 0000 0000 00000
24. IFET(8)=IFET(8).OR.4000 0000 0000 0000 00000
25. CALL FET(5LTAPE1, IFET, -8)
26. *C
27. TUXMIN=-0.10
28. TUXMAX=0.95
29. TUYMIN=0.15
30. TUYMAX=0.9
OK - -EDIT

```

0,63L!

OK - ^EDIT

```
30.          TUVMAY=0.9
31.          NST=-3 $ NEND=3 $ FC=1
32.          LIMFLG=0 $ LFRST=0 $ NRES=10
33.          GO TO 10
34.          1  CALL WHTNXT(N)
35.          GO TO (10,20,30,40,50,60,70,80,90),N
36.          10 CALL TUNEXT
37.          WRITE(1,11) $ CALL ENDREC(1)
38.          11 FORMAT(ENTER PLOT TITLE*)
39.          READ(1,12)LINE
40.          12 FORMAT(7A10)
41.          IF(LFRST EQ.0) GO TO 20
42.          GO TO 1
43.          20 WRITE(1,21) $ CALL ENDREC(1)
44.          21 FORMAT(ENTER EXPONENTS OF LOWER AND UPPER FREQS. IN HZ
*)
45.          CALL GET(R) $ NST=IFIX(R(1)) $ NEND=IFIX(R(2))
46.          NDEC=NEND-NST $ NPT=NDEC*NRES+1
47.          WRITE(1,23) $ CALL ENDREC(1)
48.          23 FORMAT(ENTER CUTOFF FREQUENCY IN HZ*)
49.          CALL GET(R) $ FC=R(1)
50.          CALL GHPHSE(NST,NEND,FC)
51.          XMIN=XLT=FLOG(1)
52.          XMAX=XPT=FLOG(NPT)
53.          LIMFLG=0
54.          LFRST=1
55.          GO TO 1
56.          30 WRITE(1,31) $ CALL ENDREC(1)
57.          31 FORMAT(ENTER NEW LOWER AND UPPER ORDINATES, IN DB OR
DEC*)
58.          CALL GET(R) $ YLO=R(1) $ YUP=R(2)
59.          WRITE(1,33) $ CALL ENDREC(1)
60.          33 FORMAT(ENTER NEW NUMBER OF DIVISIONS ON ORDINATE*)
```

60,90L!

```
60          33 FORMAT(*ENTER NEW NUMBER OF DIVISIONS ON ORDINATE*)
61          CALL GET(R) $ MAJR=IFIX(R(1))
62          LIMFLG=1
63          GO TO 1
64          40 WRITE(1,41) $ CALL ENDREC(1)
65          41 FORMAT(*ENTER NEW NUMBER OF POINTS PER DECADE*)
66          CALL GET(R) $ NPRES=IFIX(R(1))
67          GO TO 30
68          50 IF(LIMFLG.EQ.1) GO TO 45
69          CALL SETFLT(GNOB,NPT,MAJR,YUP,YLO)
70          GO TO 45
71          60 IF(LIMFLG.EQ.1) GO TO 45
72          CALL SETPLT(PH,NPT,MAJR,YUP,YLO)
73          GO TO 45
74          45 YMAX=YUP
75          YMIN=YLO
76          CALL TUNEXT
77          CALL BORDER
78          NXMINR=5 $ IF(NDEC.LE.3)NXMINR=9
79          CALL AXID(1,2,2,NDEC,NXMINR)
80          CALL AXID(2,2,1,MAJR,5)
81          CALL LABAX(1,2,NDEC,XLT,XRT)
82          CALL LABAX(2,1,MAJR,YLO,YUP)
83          KK=10HFREQ IN HZ
84          CALL LABNAM(1,10,KK)
85          IF(N.EQ.5) KK=10HGAIN IN DB
86          IF(N.EQ.6) KK=10HDEG PHASE
87          CALL LABNAM(2,10,KK)
88          IF(N.EQ.5) CALL TUPLOT(FLOG,GNOB,NPT,4HLINE)
89          IF(N.EQ.6) CALL TUPLOT(FLOG,PH,NPT,4HLINE)
90          XT=XLT-0.2*(XRT-XLT) $ YT=YUP+0.1*(YUP-YLO)
```

OK - ~EDIT

90,120L!

```
90.          XT=XLT-0.2*(YPT-YLT) $ YT=YUP+0.1*(YUP-YLO)
91.          ITUNE(3)=0
92.          CALL TULTRC(XT,YT,LINE,70)
93.          LIMFLG=0
94.          CALL TUSEND
95.          CALL GET(R)
96.          GO TO 1
97.          STOP
98.          STOP
99.          STOP
100.         END
101.         SUBROUTINE WHTNXT(N)
102.         DIMENSION K(9),R(10)
103.         DATA (K(I),I=1,9)/10HNEW TITLE ,10HNEW FREQS ,10HNEW L
IMITS,
104.         *10HNEW RESLTH,10HPLOT GAIN ,10HPLOT PHASE,10H  STOP
105.         *2*4HNULL/
106.         1  WRITE(1,5)
107.         CALL ENDFECC(1)
108.         5  FORMAT(2Y, 'WHAT NEXT?')
109.         DO 3 J=1,3
110.         J1=3*(J-1)+1 $ J2=3*(J-1)+2 $ J3=3*J
111.         WRITE(1,7)J1,K(J1),J2,K(J2),J3,K(J3)
112.         7  FORMAT(3(5X,I2,'=' ,A10))
113.         8  CALL ENDFECC(1)
114.         CALL GET(R) $ N=IFIX(R(1))
115.         RETURN
116.         END
117.         SUBROUTINE GNPHSE(NST,NEND,FC)
118.         COMMON MFES,BLANK(5)
119.         COMMON TFF,FLOG(500),GNDB(500),PHK 500)
120.         COMPLEX J,S,T
```

20, 150!

```
120. COMPLEX J,S,T
121. NDEC=NEND-NST $ NPT=NDEC*NRES+1
122. PI=3.141592653
123. L2=9 $ NWRAP=0
124. J=(0.,1.)
125. DO 10 I=1,NPT
126. FLOG(I)=FLOAT(NST)+FLOAT(I-1)/FLOAT(NRES)
127. F=10.**FLOG(I) $ S=J*F/FC
128. CALL TRFUNK(S,T)
129. GN=ABS(T)
130. GNDB(I)=20 *ALOG10(GN)
131. P=ATAN2(AIMAG(T),REAL(T))
132. L1=L2
133. L2=INT(2.*P/PI)
134. IF(L1.EQ.0) GO TO 20
135. IF(L2.EQ.0) GO TO 20
136. L3=ISIGN(1,L1)-ISIGN(1,L2)
137. IF(L3.EQ.0)GO TO 20
138. NWRAP=NWRAP-ISIGN(1,L2)
139. PH(I)=P*180./PI+FLOAT(NWRAP*360)
140. CONTINUE
141. RETURN
142. END
143. SUBROUTINE SETPLT(A,N,MAJR,PMAX,PMIN)
144. DIMENSION A(1)
145. CALL MAXMIN(A,N,BMAX,BMIN)
146. CMAX=ABS(BMAX) $ CMIN=ABS(BMIN)
147. TMAX=AMAX1(CMAX,CMIN)
148. CALL PNDCTMAX,BMAX,NT)
149. NCHK=2*NT $ MAJR=0 $ TSTEP=RMAX/NT
150. IF(TMAX.NE.CMAX)GO TO 10
```

OK - ^EDIT

```

150,130L!
150. IF(TMAX.NE.CMAX)GO TO 10
151. DO 15 I=1,NCHK
152. MAJR=MAJR+1
153. IF((RMAX-MAJR*TSTEP).GT.(BMIN-TSTEP/5.)) GO TO 15

154. PMAX=RMAX. $ PMIN=RMAX-MAJR*TSTEP
155. GO TO 30
156. 15 CONTINUE
157. 10 DO 20 II=1,NCHK
158. MAJR=MAJR+1
159. IF((-RMAX+MAJR*TSTEP).LT.(BMAX+TSTEP/5.))GO TO 20

160. PMIN=-RMAX. $ PMAX=-RMAX+MAJR*TSTEP
161. GO TO 30
162. 20 CONTINUE
163. 30 IF(MAJR.EQ.1)WRITE(1,50)BMIN,BMAX
164. IF(MAJR.EQ.2)MAJR=4
165. IF(MAJR.EQ.3)MAJR=5
166. 50 FORMAT(41H WARNING, OFDINATE RANGE IS SMALL, FROM
167. * ,E15.5,6H TO ,E15.5,6H ONLY)
168. RETURN
169. END
170. SUBROUTINE RND(A,ABIG,MAJR)
171. DIMENSION RD(9),MR(9)
172. DATA(RD(I), I=1,9)/1.,1.5,2.,3.,4.,5.,6.,8.,10./
173. DATA(MR(J), J=1,9)/4,6,4,6,4,5,6,4,5/
174. AL=A*LOG10(ABS(A))
175. CHAR=AL-AINT(AL)
176. IF(AL.LT.0) CHAR=AL-AINT(AL)+1.
177. D=10.**CHAR
178. IF(D.EQ.10.) D=1.
179. DO 10 K=1,8
180. IF(D.LT.RD(K)) GO TO 10

```

OK - ^EDIT

80.210!

```
180. IF(D.LT.R0CK) GO TO 10
181. IF(D.GE.R0CK+1) GO TO 10
182. MAJR=MR(K+1)
183. ABIG=R0CK+1)*A/D
184. GO TO 15
185. 10 CONTINUE
186. 15 CONTINUE
187. RETURN
188. END
189. SUBROUTINE MAXMIN(A,N,BMAX,BMIN)
190. DIMENSION A(200)
191. BMAX=BMIN=A(1)
192. DO 10 I=1,N
193. IF(A(I).GT.BMAX) BMAX=A(I)
194. IF(A(I).LT.BMIN) BMIN=A(I)
195. 10 CONTINUE
196. RETURN
197. END
198. SUBROUTINE AX TIC(NAXIS,NBOTH,LINLOG,MAJR,MINR)
199. COMMON/TUTUNE/ITUNE(30)
200. COMMON/UFLOT/XLT,XRT,YLO,YUP
201. DIMENSION A(200),BL(200),BU(200)
202. ITUNE(15)=4HDATA
203. ATIC=0.03*(YUP-YLO)
204. BTIC=0.03*(XRT-XLT)
205. IF(MINR.EQ.0) NOIU=MAJR
206. IF(MINR.NE.0) NOIU=MINR*MAJR
207. IF(NAXIS.EQ.2) GO TO 10
208. BLMN=YLO+0.4*ATIC
209. BHMN=YUP-0.4*ATIC
210. BLMJ=YLO+ATIC
```

OK - ^EDIT

210, 240L!
210.
211.
212.
213.
214.
215.
216.
217.
218.
219.
220.
221.
222.
223.
224.
225.
226.
227.
228.
229.
230.
231.
232.
233.
234.
235.
236.
237.
238.
239.
240.
OK - -EDIT

```
BLMJ=YLO+ATIC  
BHMJ=YUP-ATIC  
ALO=XLT  
AHI=XRT  
BLO=YLO  
BHI=YUP  
GO TO 20  
10  
BLMN=XLT+.4*BTIC  
BHMN=XRT-.4*BTIC  
BLMJ=XLT+BTIC  
BHMJ=XRT-BTIC  
ALO=YLO  
AHI=YUP  
BLO=YLT  
BHI=XRT  
20  
MNR=MINR-1  
ADIU=NOIU  
AMINR=(AHI-ALO)/ADIU  
AMJR=(AHI-ALO)/MAJR  
J=-1  
LOGSET=INT(10 /FLOAT(MNR))  
IF(LINLOG EQ. 2. A MNR. EQ. 8)MNR=9  
DO 30 I=1,MAJR  
J=J+2  
AMJNK=ALO+(I-1)*AMJR  
AK(J)=AMJNK  
AK(J+1)=AK(J)  
BL(J)=BLO  
BL(J+1)=BLMJ  
BUK(J)=BHI  
BUK(J+1)=BHMJ
```

40,27DL!

```
240.      BUK(J+1)=BHMJ
241.      IF(MINR.EQ.0) GO TO 30
242.      DO 40 II=1,MINR
243.      J=J+2
244.      IF(LINLOG.EQ.1) AK(J)=AMJMK+AMINR*II
245.      IF(LINLOG.EQ.2) AK(J)=AMJMK+AMJR*ALOG10(FLOAT(II)*LOGSET
))
246.      A(J+1)=A(J)
247.      BL(J)=BLO
248.      BL(J+1)=BLMN
249.      BUK(J)=BHI
250.      BUK(J+1)=BHMN
251.      40 CONTINUE
252.      30 CONTINUE
253.      J=J+1
254.      IF(NBOTH.EQ.3) GO TO 45
255.      IF(NAXIS.EQ.1) CALL TUPLOT(A,BL,J,7HSEGMENT)
256.      IF(NAXIS.EQ.2) CALL TUPLOT(BL,A,J,7HSEGMENT)
257.      IF(NBOTH.EQ.1) GO TO 50
258.      45 CONTINUE
259.      IF(NAXIS.EQ.1) CALL TUPLOT(A,BU,J,7HSEGMENT)
260.      IF(NAXIS.EQ.2) CALL TUPLOT(BU,A,J,7HSEGMENT)
261.      50 CONTINUE
262.      RETURN
263.      END
264.      SUBROUTINE LABNAM(NAXIS,NLET,KNAME)
265.      COMMON /JPLT/XLT,XRT,YLO,YUP
266.      COMMON /TUTUNE/ITUNE(30)
267.      DIMENSION KLAB(10)
268.      ITUNE(3)=NAXIS-1
269.      IF(NAXIS.EQ.1) GO TO 10
270.      ST2=0.15
```

OK - ^EDIT

0,300L!

```
270.      ST2=0.15
271.      XX=XLT-ST2*(YRT-XLT)
272.      YY=YLO+.375*(YUP-YLO)
273.      GO TO 30
274.      10  ST1=0.18
275.          YY=YLO-ST1*(YUP-YLO)
276.          XX=XLT+.375*(XRT-XLT)
277.      30  ENCODE(NLET,20,KLAB) KNAME
278.      20  FORMAT(A10)
279.          CALL TULTR(XY,YY,KLAB,NLET)
280.          RETURN
281.      END
282.      SUBROUTINE BORDER
283.      COMMON/JPLOT/XLT,XRT,YLO,YUP
284.      DIMENSION X(5),Y(5)
285.      X(1)=XLT
286.      X(4)=XLT
287.      X(5)=XLT
288.      X(2)=XRT
289.      X(3)=XRT
290.      Y(1)=YLO
291.      Y(2)=YLO
292.      Y(3)=YUP
293.      Y(4)=YUP
294.      Y(5)=YLO
295.      CALL TUPLOT(X,Y,5,4HLINE)
296.      RETURN
297.      END
298.      SUBROUTINE LABAX(NAXIS,LINLOG,MAJR,ALL,ALH)
299.      COMMON/TUTUNE/ITUNE(30)
300.      COMMON/JPLOT/XLT,XRT,YLO,YUP
```

OK - ^EDIT

300, 330L!

```
300. COMMON /JPL0T/ XLT, XRT, YLO, YUP
301. DIMENSION LABEL(20)
302. ITUNE(3)=0 $ MLAB=MAJR+1
303. IF(NAXIS.EQ.2) GO TO 30
304. ALO=XLT $ AHI=XRT
305. BLO=YLO $ BHI=YUP
306. STA=0.02 $ STE=0.08
307. GO TO 40
308. 30 ALO=YLO
309. AHI=YUP
310. BLO=XLT $ BHI=XRT
311. STA=0.02 $ STE=0.12
312. 40 BPOS=BLO-STA*(BHI-BLO)
313. AMJR=(AHI-ALO)/MAJR $ ALMJ=(ALH-ALL)/MAJR
314. AST=ALO-STA*(AHI-ALO)
315. DO 50 JK=1,MLAB
316. APOS=AST+AMJR*(JK-1)
317. AVAL=ALL+ALMJ*(JK-1)
318. ENCODE(6,42,LABL(JK))AVAL
319. IF(LINLOG.EQ.2) ENCODE(3,43,LABL(JK))AVAL
320. 42 FORMAT(F6.1)
321. 43 FORMAT(F3.0)
322. NN=6 $ IF(LINLOG.EQ.2) NN=3
323. IF(NAXIS.EQ.1) CALL TULTR(APOS,BPOS,LABL(JK),NN)
324. IF(NAXIS.EQ.2) CALL TULTR(BPOS,APOS,LABL(JK),NN)
325. 50 CONTINUE
326. IF(LINLOG.EQ.1) GO TO 60
327. BPOS=BPOS-0.02*(BHI-BLO)
328. AST=AST-0.02*(AHI-ALO)
329. LL=2H10
330. ENCODE(2,44,KLL)LL
```

OK - ^EDIT

30, 360L!

```
330 ENCODE(2,44,KLL)LL
331 44 FORMAT(A2)
332 DO 55 JKK=1,MLAB
333 APOS=AST+AMJR*(JKK-1)
334 IF(NAXIS.EQ.1) CALL TULTR(APOS,BPOS,KLL,2)
335 IF(NAXIS.EQ.2) CALL TULTR(BPOS,APOS,KLL,2)
336 55 CONTINUE
337 60 CONTINUE
338 RETURN
339 END
340 $GET SUBROUTINE — GET A SEQUENCE OF NUMS — FREE FORMAT
341 SUBROUTINE GET(R)
342 INTEGER DIG(70),D,S,ND(10),FMT(6),BEG,LINE(7),OI
343 REAL P(10)
344 99 READ(1,1)LINE $ DECODE(70,2,LINE)DIG
345 N=S=NS=NP=OI=0 $ J=1
346 DO 10 I=1,70
347     D=DIG(I) $ IF(S.EQ.0.A.D.EQ.45)GOTO 10
348     NS=1 $ IF(S.EQ.0.A.D.GE.27.A.D.LE.38)GOTO 10
349     INDEX=I
350     IF(D.EQ.47.A.NP.EQ.1) GO TO 98 $ IF(D.EQ.47)NP=1
351     IF(D.EQ.47) GO TO 10 $ IF(S.EQ.0) GO TO 99
352     IF(D.GE.27.A.D.LE.36)GOTO 10
353     N=N+1 $ ND(N)=I-OI-1 $ OI=I $ NS=0 $ NP=0
354 10     S=NS
355     BEG=N+1 $ ENCODE(50,3,FMT*ND(I),I=1,N),(J,I=BEG,11)
356     DECODE(70,FMT,LINE*(R(I),I=1,N) $ RETURN
357 98 WRITE(1,4)INDEX $ GOTO 99
358 1 FORMAT(7A10)
359 2 FORMAT(70R1)
360 3 FORMAT(*(F*,10(I2,*,YF*),11,*)*)
```

OK - ^EDIT

360,390L!

```

360      3 FORMAT*(F#.10(I2,*,XF*),I1,*)*
361      4 FORMAT*(ERROR ON CHAR#,I3,* -- RE-ENTER LINE*)
362      END
363      SUBROUTINE TRFUNC(S,T)
364      COMPLEX S,T,J,P(10)
365      PI=3.141592653 * J=(0.,1.)
366      N=5
367      P(1)=(-1.5023,0.)
368      P(2)=(-1.3808,.7179)
369      P(3)=(-1.3808,-.7179)
370      P(4)=(-.9576,1.4711)
371      P(5)=(-.9576,-1.4711)
372      T=(1.,0.)
373      DO 10 I=1,N
374      10  T=T*P(I)/(S-P(I))
375      RETURN
376      END
377      SUBROUTINE TRFUNC(S,T)
378      COMPLEX S,T,J,P(10)
379      PI=3.141592653 * J=(0.,1.)
380      Q=02.
381      N=5
382      A=SIN(PI/10.)
383      B=COS(PI/10.)
384      C=SIN(PI/5.)
385      D=COS(PI/5.)
386      P(1)=-A+J*B
387      P(2)=-D+J*C
388      P(3)=-1.
389      P(4)=-D-J*C
390      P(5)=-A-J*B

```

OK - ^EDIT

390,400L!

```

390      P(5)=-A-J*B
391      T=(1.,0.)
392      DO 10 I=1,N
393      10  T=T*P(I)/(S-P(I))
394      RETURN
395      END

```

OK - ^EDIT

NOTES TO APPENDIX A

1. As shown here, the main program and the subroutine GNPHSE plot either gain or phase on a linear scale along the Y-axis. The ordinate labels appear as absolute numbers, not as exponentials, e.g., as -100 to 100, not -10^2 to 10^2 . The resultant plots look like Figures 4.2 through 4.9.

2. Certain changes must be made to produce plots like those in Figures 5.1 and 5.3, with logarithmic ordinates and appropriate numeric labels. For such plots, change the following lines of the main program and of subroutine GNPHSE as shown below:

```
80      CALL AXTIC(2,2,2,MAJR,5)
82      CALL LABAX(2,2,MAJR,YLO,YUP)
85      IF(N.EQ.5) KK=10H V/MICRON      [or other appropriate label]
130     GNDB(I)=ALOG10(GN)
```

The original forms of these lines appear on pages 61 and 63.

3. Note that NETED does not output line numbers. The lines above can be found, however, using NETED's locate (L) command. For example, the first line above could be found using the command

```
L CALL AXTIC(2 (return)
```

and thereafter the other lines could be found using the commands

```
N 2 (return)
```

```
N 3 (return)
```

```
N 45 (return)
```