

DOE/ET/27010-1

MC COY AREA, NEVADA  
Geothermal Reservoir Assessment Case History  
Northern Basin and Range

FINAL REPORT

1 October 1978 - 30 September 1982

H. D. PILKINGTON

AMAX EXPLORATION, INC.  
1707 Cole Blvd.  
Golden, Colorado 80401

PREPARED FOR THE U. S. DEPARTMENT OF ENERGY  
DIVISION OF ENERGY TECHNOLOGY

Under Contract DE-AC08-79ET27010

## DISCLAIMER

This report was prepared as an account of work sponsored by the United States Government. Neither the United States nor the United States Department of Energy, nor any of their employees, makes any warranty, express or implied, or assumes any legal liability or responsibility for the accuracy, completeness, or usefulness of any information, apparatus, product, or process disclosed, or represents that its use would not infringe privately owned rights. Reference herein to any specific commercial product, process, or service by trade name, mark, manufacturer, or otherwise, does not necessarily constitute or imply its endorsement, recommendation, or favoring by the United States Government or any agency thereof. The views and opinions of authors expressed herein do not necessarily state or reflect those of the United States Government or any agency thereof.

Printed in the United States of America

Available from:

National Technical Information Service  
U. S. Department of Commerce  
5285 Port Royal Road  
Springfield, Virginia 22161

Price: Printed Copy \$\_\_\_\_ (See Appendix D)  
Microfiche \$4.00 - Code A-01

Price of the printed copy is determined by the number of pages in the report. Since prices are revised periodically, contact the Contracting Officer for current prices.

DOE/ET/27010-1

MC COY AREA, NEVADA  
Geothermal Reservoir Assessment Case History  
Northern Basin and Range

FINAL REPORT

1 October 1978 - 30 September 1982

H. D. PILKINGTON  
October 1982

WORK PERFORMED UNDER CONTRACT  
DE-AC08-79ET27010

AMAX EXPLORATION, INC.  
1707 Cole Blvd.  
Golden, Colorado 80401

## TABLE OF CONTENTS

	Page
ABSTRACT.....	1
INTRODUCTION.....	2
EXPLORATION HISTORY.....	2
Geological Studies.....	2
Geochemical Studies.....	4
Geophysical Studies.....	25
Exploration Drilling.....	34
Shallow Thermal Gradient Holes.....	34
Intermediate Depth Exploration Wells.....	38
RESERVOIR ASSESSMENT.....	57
Geological Manifestations.....	57
Geophysical Manifestations.....	58
Geochemical Manifestations.....	65
BIBLIOGRAPHY.....	68

## TABLE OF ILLUSTRATIONS

		Page
Figure 1.	Location map for the McCoy geothermal prospect.....	3
Figure 2.	Geologic map of the McCoy geothermal prospect, Nevada (after Adams, Moore and Struhsacker, 1980).....	5
Figure 3.	Geologic cross-sections through well 14-7 (top) and well 66-8 (bottom) after Pilkington, (1980).....	6
Figure 4.	Hydrogeochemical sample map for the McCoy prospect, Nevada.....	7
Figure 5.	Na versus K in waters from the McCoy area, Nevada.....	21
Figure 6.	Location map of drill holes used on geochemical study of drill cuttings.....	23
Figure 7	Contour map of mercury in drill cuttings from 120-160 foot interval at McCoy (Pilkington, 1980).....	24
Figure 8	Heatflow map showing thermal anomaly shaded, highest HF striped and lowest shaded (Lange, 1980)..	26
Figure 9.	Residual aeromagnetic map. Highs are stippled, lows striped (Lange, 1980).....	27
Figure 10.	Complete Bouguer gravity map. Highs stippled, lows striped (Lange, 1980).....	28
Figure 11.	Gravity profile with automatic interpretation for density (top) after Berkman (1980) compared with geologic section after Pilkington (1980).....	29
Figure 12	Resistivity at 5km depth from ID magnetotelluric inversion (Te mode). Conductive zones striped, resistive striped (Lange, 1980).....	30
Figure 13	MT section (Te mode, ID inversion) along line C compared with geologic section (Lange, 1980).....	31
Figure 14	Survey location map of the McCoy prospect, after Wilt et al, 1980.....	32
Figure 15	MT section (Te mode ID inversion) along line A compared with available EM data, after Lange, 1980....	33
Figure 16.	Location of resistivity profile lines.....	35

TABLE OF ILLUSTRATIONS

Page

Figure 17. Resistivity survey, McCoy Project, Nevada line B and C.....36

Figure 18. Resistivity survey, McCoy Project, Nevada, line D.....37

Figure 19. Well completion schematic diagram for 66-8.....43

Figure 20. Well completion schematic diagram for 14-7.....47

Figure 21. Well completion schematic diagram for 25-9.....51

Figure 22. Well completion schematic diagram for 38-9.....53

Figure 23. Well completion schematic diagram for 28-18.....55

Figure 24. Temperatures at five different depths in each of the McCoy wells indicated. The deeper curves are essentially amplified versions of the shallow curves..59

Figure 25. Plan view of the thermal anomaly at McCoy, Nevada. (a) Temperature at 3m, (b) Temperature at 30m (both adjusted for altitude), after Lange et al, 1982.....60

Figure 26. Linearly extrapolated isotherms superimposed upon geologic sections through well 14-7 and well 66-8 McCoy Prospect, Nevada (after Pilkington, 1980 and Lange, 1981).....61

Figure 27. Three-dimensional downward continuations, pure conductive model, with isotherms superimposed on geologic sections through well 14-7 and well 66-8, after Lange, 1981.....63

Figure 28. Three-dimensional downward continuation with extended aquifers ( $T_{1a}$  limestone at wells 14-7 and  $T_{1c}$  conglomerate at well 66-8) superimposed on geologic sections, after Lange 1981.....64

TABLES

Page

Table I	Chemical analyses of McCoy area waters.....	8
Table II	Cl/HCO <sub>3</sub> and Cl/SO <sub>4</sub> mole ratio comparisons for McCoy waters.....	22
Table III	Generalized drilling plan, McCoy exploration wells....	38
Table IV	Drilling history well 66-8, McCoy prospect, Nevada....	39
Table V	Logging history for well 66-8, McCoy prospect, Nevada.....	42
Table VI	Drilling history well 14-7, McCoy prospect, Nevada....	42
Table VII	Logging history for well 14-7, McCoy prospect, Nevada.....	46
Table VIII	Drilling history well 25-9, McCoy prospect, Nevada....	48
Table IX	Logging history for well 25-9, McCoy prospect, Nevada.....	50
Table X	Drilling history for well 38-9, McCoy prospect, Nevada.....	50
Table XI	Logging history for well 38-9, McCoy prospect, Nevada.....	52
Table XII	Drilling history for well 28-18, McCoy prospect, Nevada.....	54
Table XIII	Chemical geothermometry summary, McCoy thermal waters.....	66

## ABSTRACT

The McCoy geothermal prospect is located in north-central Nevada at the junction of the Augusta Mountains, Clan Alpine Mountains and the New Pass Range. The prospect was discovered in 1977, and in 1978 was made a part of the Geothermal Reservoir Assessment Case Study Program of the Department of Energy under contract DE-AC08-79ET27010.

Geothermal exploration on the prospect consisted of an integrated program of geologic, geochemical and geophysical studies. The geochemical studies included hydrogeochemistry, soil geochemistry, and drill cuttings geochemistry. Geophysical exploration included heatflow studies, aeromagnetic, self-potential, gravity, passive seismic, dipole-dipole resistivity, electromagnetic and magnetotelluric surveys. Exploration drilling includes fifty-two (52) shallow thermal gradient holes and five (5) intermediate depth temperature gradient wells.

Shallow low-temperature geothermal reservoirs were encountered in two areas. In the McCoy Mine area the resource was found in the Permian-Pennsylvanian rocks. In the southern part of the prospect a resource with temperatures of 100°C was encountered in the basal conglomeratic sandstone of the Triassic section.



## INTRODUCTION

The McCoy geothermal prospect was discovered in 1977 during reconnaissance coverage of Nevada. The prospect was identified by thermal gradient measurements of existing holes and hydrogeochemical analysis of water from the McCoy Mine water well. The prospect is located approximately 72 kilometers northwest of Austin, Nevada (Figure 1) and can be reached by means of a graded road which leads from U. S. Highway 50.

The McCoy prospect is located at the confluence of the Augusta and Clan Alpine Mountains and the New Pass Range. The prospect straddles the Churchill and Lander County borders.

In 1978, AMAX submitted a proposal in response to the Department of Energy's RFP No. ET-78-R-08-003, Geothermal Reservoir Assessment Case Study, Northern Basin and Range and was awarded a contract providing partial funding for exploration at the property. Results of the work funded through the DOE are summarized in this report. Reproductions of the various data packages are available from: University of Utah Research Institute, Earth Science Lab, 420 Chipeta Way, Salt Lake City, Utah 84108.

## EXPLORATION HISTORY

The geothermal exploration partially funded under DOE contract DE AC08-79ET27010 was an integrated approach including geological, geochemical and geophysical studies as well as exploration drilling. For the purpose of this report the exploration will be discussed under exploration methods rather than a chronological description.

## GEOLOGICAL STUDIES

The McCoy geothermal prospect is located at the junction of the Augusta Mountains, the Clan Alpine Mountains and the New Pass Range. The area is underlain by Tertiary volcanics and associated sediments, Triassic sediments and Permian-Pennsylvanian eugeosynclinal sediments as shown on the county maps (Stewart, J. H. and McKee, E. H., 1977 and Wilden, R. and Speed, R. L., 1974). The county geologic maps are at a scale of 1:250,000 and, therefore, do not show much detail.

In the late fall of 1979 Joe Moore of the University of Utah Research Institute began a geologic mapping program under DOE contract DEAC 07 - 80

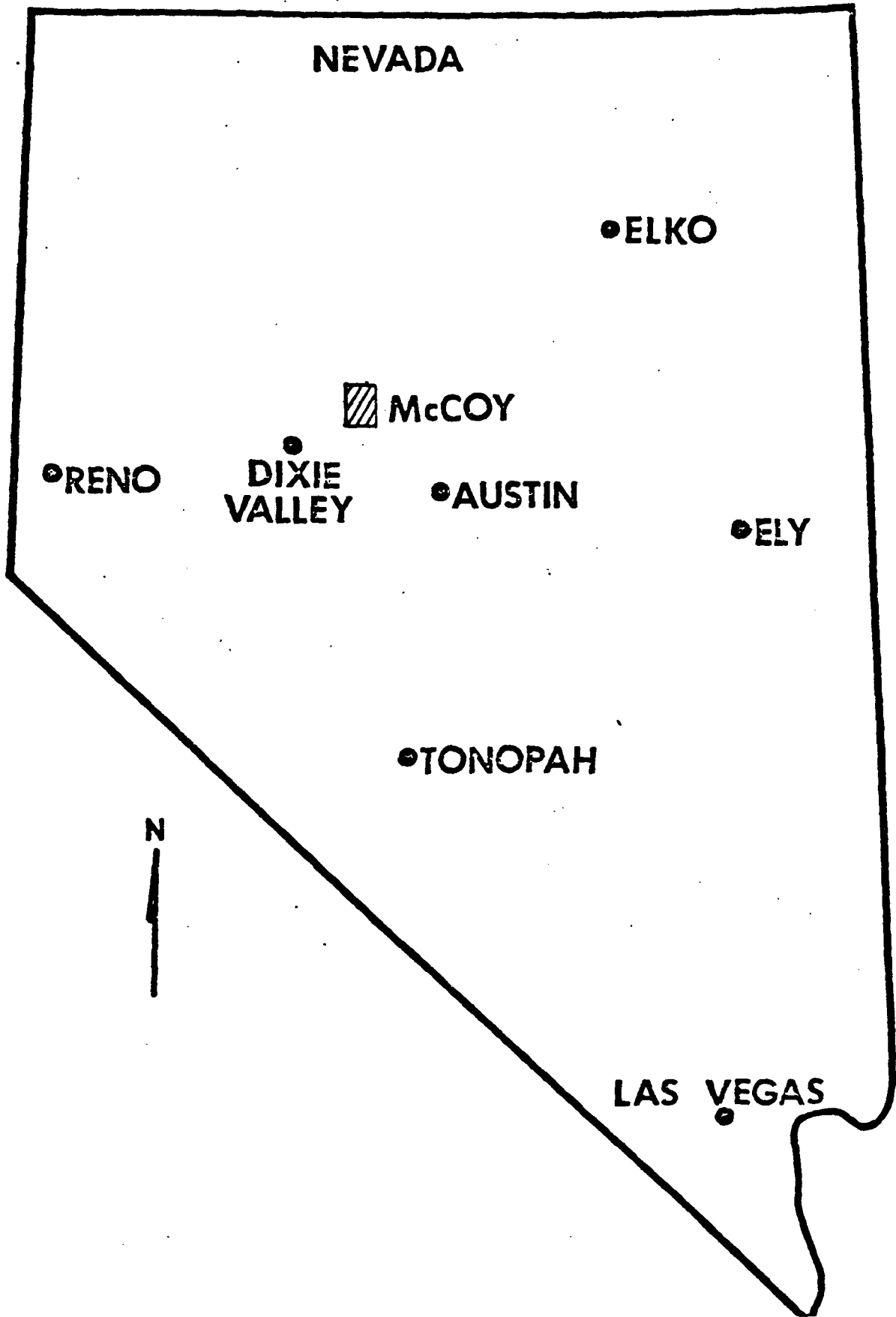

Figure 1. Location map for the McCoy geothermal project.

ID 12079. Joe Moore and Eric Struhsacker established the mapping units in the Tertiary volcanics and then Mike Adams of UURI did most of the field mapping in 1980. A detailed geologic map at a scale of 1:24,000 was completed (Figure 2) in 1980 (Pilkington, 1981). During 1981, the geologic mapping was extended to the south in order to establish a better understanding of the relationship between the Tertiary, Triassic and Permo-Pennsylvanian rocks.

The oldest rocks mapped in the McCoy area are the cherts, volcanics, siltstones, sandstones and minor limestones of the Havallah sequence of Permo-Pennsylvanian age. The rocks were deformed, uplifted and deeply eroded prior to the deposition of the basal Triassic sediments which consist of conglomerates, siltstones, sandstones and minor tuff. The basal member is overlain by several hundred feet of dominantly carbonate sediments of the Favret Formation, the Augusta Mountain Formation and the Cone Springs Formation. The uppermost Triassic unit consists of the detrital sediments of the Osobb Formation.

The Tertiary volcanic rocks in the McCoy area (Fig. 2) range in age from about 36 m.y. to 15 m.y. (McKee and Stewart, 1971). Sedimentary rocks are found at various horizons within the volcanic units. A considerable thickness of sediments overlies the volcanic rocks to the northwest of the McCoy Mine area. West of the McCoy Mine over 2 km<sup>2</sup> of fossil Quaternary travertine is exposed. The travertine lies unconformably upon the eroded Triassic rocks. The travertine dips gently westward and is only slightly dissected.

Tectonically the area has had a long and complex history. The detailed mapping permitted the construction of detailed geologic cross section (Fig. 3). Reasonable approximations of the fault offsets could be made using the displacement of cooling units on Mike Adams geologic map.

#### Geochemical Studies

The hydrogeochemical analysis of a water sample from the McCoy Mine water well was one of the manifestations which attracted AMAX to the area. A total of forty-four (44) water samples have been collected at the McCoy prospect (Fig. 4). Table I compares the chemical analyses of the various water samples. The chemical geothermometers given include silica with maximum steam loss ( $T_qSiO_2$ ) and chalcedony ( $T_cSiO_2$ ) and the alkali geothermometer (TNa-K-Ca) with no magnesium corrections.

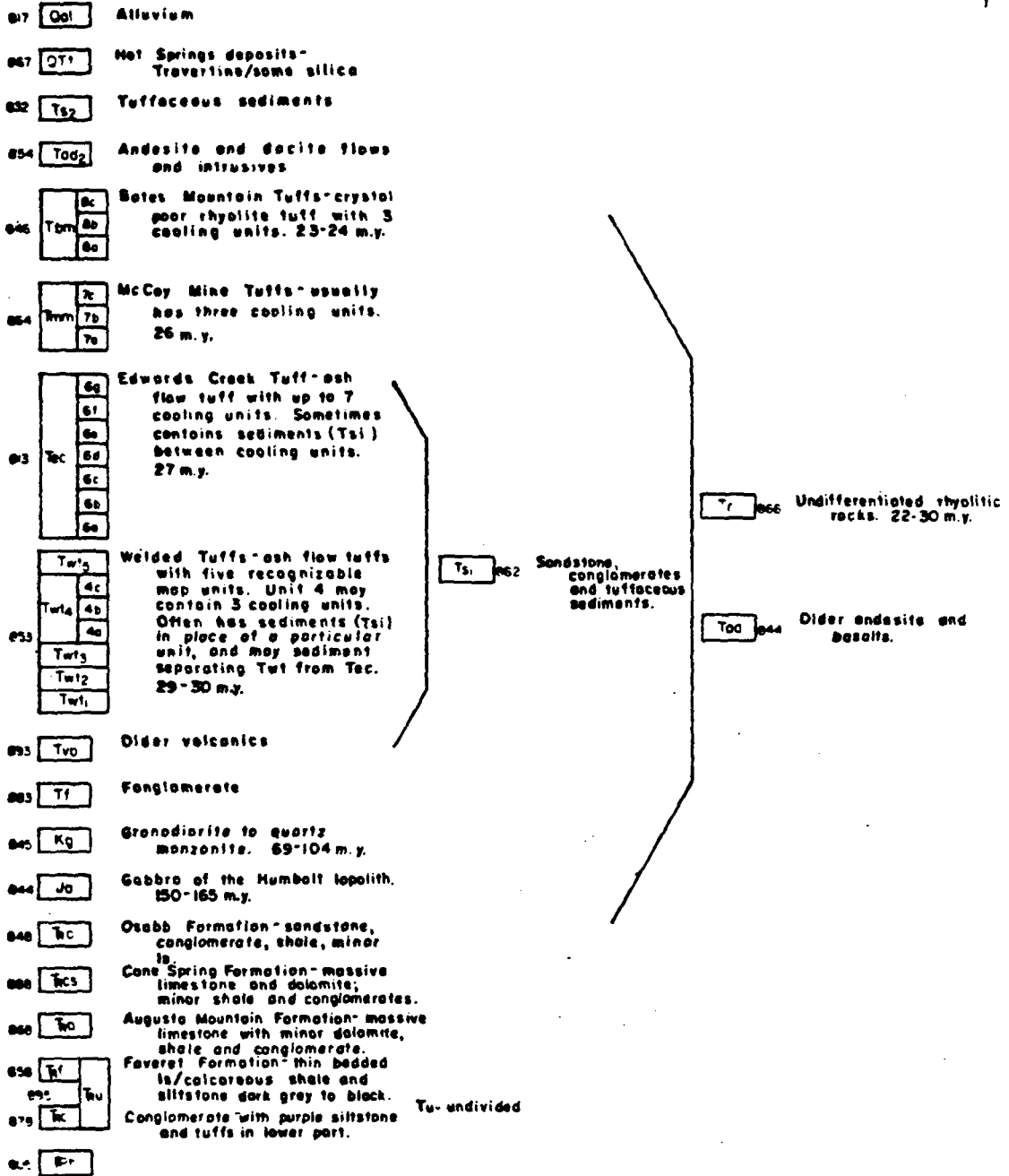

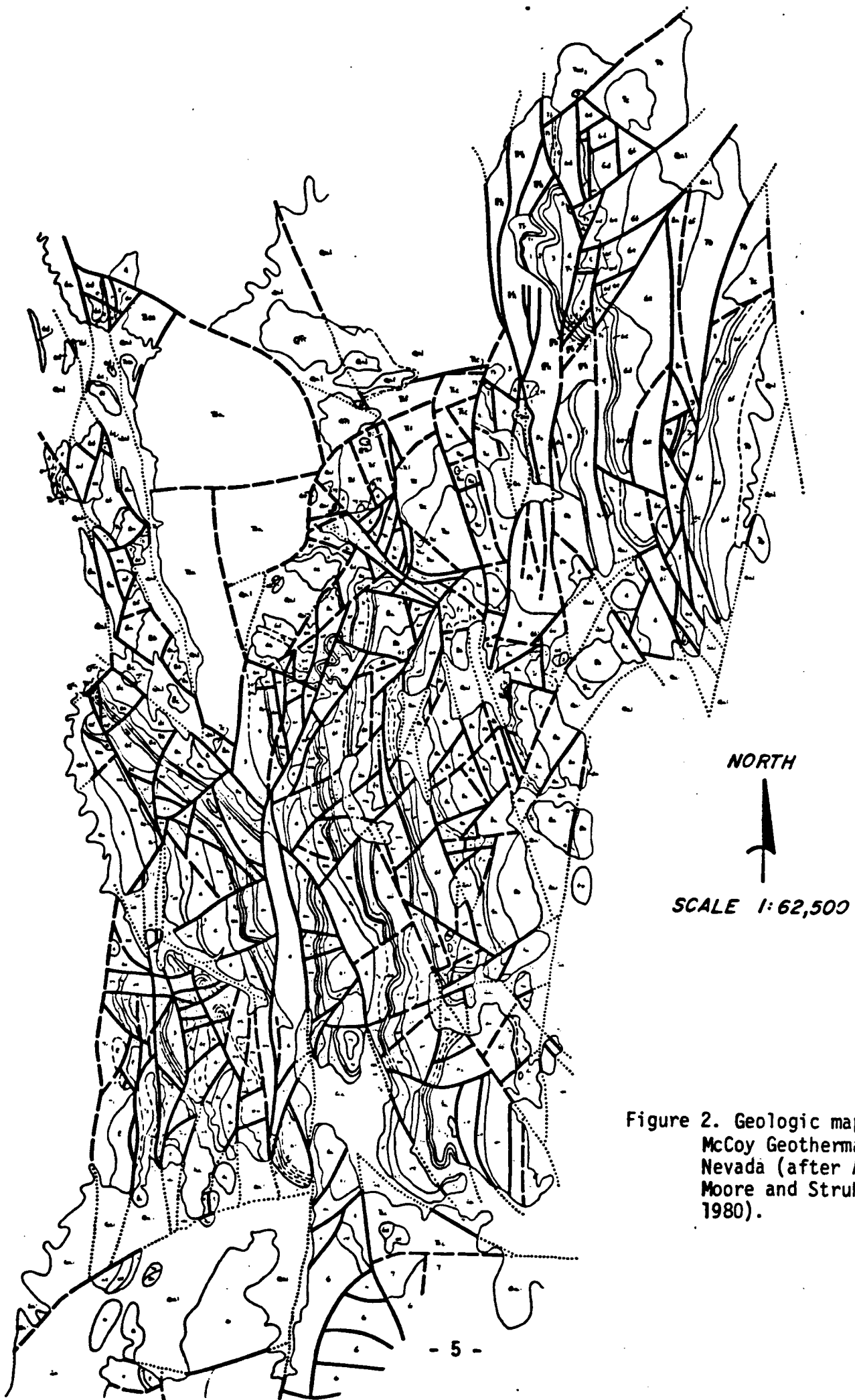

Figure 2. Geologic map of the McCoy Geothermal Prospect, Nevada (after Adams, Moore and Struhsaker, 1980).

# GEOLOGIC CROSS-SECTIONS

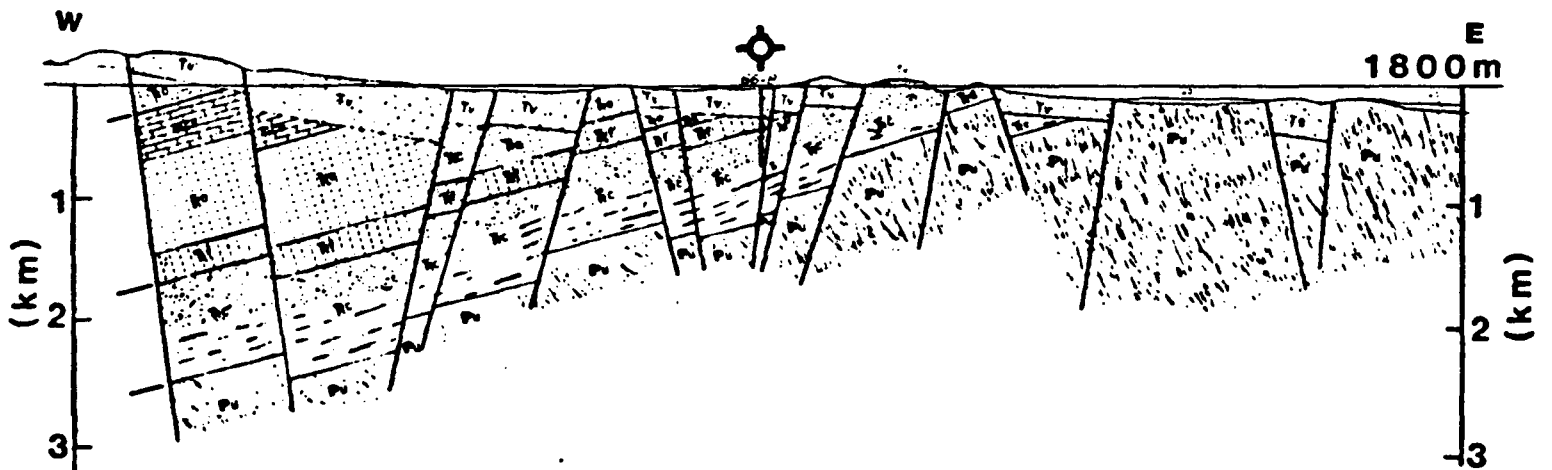
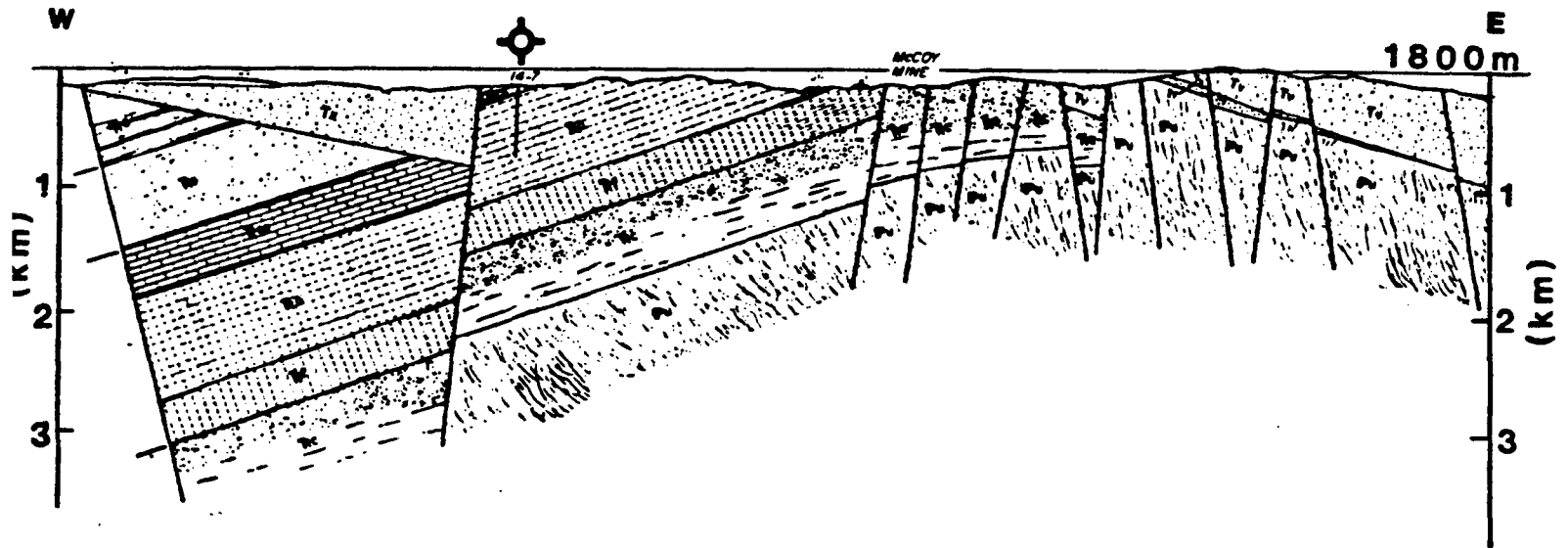

Figure 3. Geologic cross-sections through well 14-7 (Top) and well 66-8 (bottom) after Pilkington, 1980.



Table I. Chemical analyses of McCoy Area Waters

	W 10767 7 Devils W.S. <u>SWSES29T26NR38E</u>	W10768 7 Devils W.W. <u>NWSWS32T26NR38E</u>	W10769 Hyder H.S. <u>NWSWS28T25NR38E</u>	W10770 Lower Ranch H.S. <u>SWNWS16T25NR39E</u>
Temp <sup>o</sup> C	33	20	78	40
Flow (gpm)	1	ND	50	20
pH	7.39	7.35	8.59	7.41
Cl	84.0	550.0	50.0	28.0
F	5.6	0.4	8.4	3.3
SO <sub>4</sub>	460.0	180.0	125.0	65.0
HCO <sub>3</sub>	278.0	180.0	665.0	377.0
CO <sub>3</sub>	0.0	0.0	31.0	0.0
SiO <sub>2</sub>	56.0	70.0	68.0	39.0
Na	170.0	150.0	350.0	140.0
K	30.0	19.0	22.0	11.0
Ca	130.0	230.0	24.0	43.0
Mg	22.0	62.0	9.5	13.0
Li	0.8	0.2	1.9	0.3
B	1.3	0.8	4.0	1.0
TDS	1237.7	1442.4	1442.4	720.6
Ec(k)	NA	NA	NA	NA
Tq SiO <sub>2</sub>	107	117	115	93
Tc SiO <sub>2</sub>	78	90	88	60
T Na-K-Ca	101	71	167	89



Table I. Continued

	W10771 McCoy H.S. <u>SWNWS33T26NR39E</u>	W10772 H.S. <u>NWNES19T26NR40E</u>	W10802 W.S. <u>NWNWS19T25NR39E</u>	W10950 C.S. <u>SWSWS18T21NR39E</u>
Temp <sup>OC</sup>	47	41	30	15
Flow (gpm)	5	1	15	1
pH	7.08	6.75	7.10	7.90
Cl	300.0	38.0	35.0	24.0
F	1.4	7.2	2.9	2.0
SO <sub>4</sub>	210.0	100.0	130.0	50.0
HCO <sub>3</sub>	280.0	677.0	466.0	117.0
CO <sub>3</sub>	0.0	0.0	0.0	0.0
SiO <sub>2</sub>	38.0	31.0	34.0	87.0
Na	220.0	240.0	160.0	52.0
K	9.2	22.0	11.0	7.0
Ca	110.0	80.0	90.0	35.0
Mg	37.0	18.0	18.0	1.5
Li	0.2	0.8	0.4	0.2
B	0.8	0.8	1.5	0.0
TDS	1206.6	1214.8	948.8	375.7
Ec(k)	NA	NA	NA	NA
Tq SiO <sub>2</sub>	92	84	88	126
Tc SiO <sub>2</sub>	59	49	54	103
T Na-K-Ca	68	170	74	68

Table I. Continued

	W10951 W.W. <u>SESES22T21NR38E</u>	W10981 McCoy Mine W.W. <u>Sec 9 T23NR40E</u>	W10983 Cain Spr. <u>SWS5T24NR40E</u>	W10988 Hole-In-Wall W.S. <u>SWSES24T24NR38E</u>
Temp <sup>OC</sup>	25	39	18	24
Flow (gpm)	ND	ND	25	10
pH	7.90	7.05	7.75	7.53
Cl	26.0	22.0	28.0	62.0
F	0.3	4.4	0.1	1.9
SO <sub>4</sub>	90.0	54.0	60.0	500.0
HCO <sub>3</sub>	138.0	611.6	184.0	370.0
CO <sub>3</sub>	0.0	0.0	0.0	0.0
SiO <sub>2</sub>	24.0	44.0	10.0	56.0
Na	51.0	260.0	37.0	260.0
K	2.8	15.0	11.0	16.0
Ca	60.0	43.0	70.0	160.0
Mg	8.3	9.0	18.0	20.0
Li	0.0	0.3	0.0	0.5
B	0.3	1.3	0.0	1.7
TDS	400.7	1065.3	418.1	1448.1
Ec(k)	NA	NA	NA	NA
Tq SiO <sub>2</sub>	75	98	47	107
Tc SiO <sub>2</sub>	39	66	7	78
T Na-K-Ca	33	153	64	79

Table I. Continued

	W11004 Big Antelope Spr. <u>NWSWS29T22NR41E</u>	W11172 Shoshone Meadows WS <u>NESES2T22NR38E</u>	W11173 Shoshone Meadows WS <u>NESES2T22NR38E</u>	W11596 WW <u>NENWS17T25NR42E</u>
Temp <sup>o</sup> C	15	24	24	17
Flow (gpm)	10	20	1	ND
pH	7.81	7.78	8.28	7.69
Cl	19.0	45.0	140.0	53.0
F	0.3	0.7	0.9	1.9
SO <sub>4</sub>	31.0	75.0	250.0	50.0
HCO <sub>3</sub>	120.0	139.0	21.0	176.0
CO <sub>3</sub>	0.0	0.0	0.0	0.0
SiO <sub>2</sub>	56.0	33.0	48.0	52.0
Na	40.0	130.0	270.0	81.0
K	6.1	0.6	9.0	6.6
Ca	32.0	4.0	30.0	46.0
Mg	7.0	0.0	1.5	9.0
Li	0.0	0.0	0.1	0.1
B	0.2	0.4	0.6	0.4
TDS	311.6	427.7	771.1	476.0
Ec(k)	NA	NA	NA	NA
Tq SiO <sub>2</sub>	107	87	101	104
Tc SiO <sub>2</sub>	78	52	70	74
T Na-K-Ca	63	48	98	65

Table I. Continued

	W11597 WW <u>SESES10T24NR40E</u>	W13453 Well 66-8, 1630' <u>NWSE S8T22NR40E</u>	W13454 Well 66-8, 2050' <u>NWSES8T22NR40E</u>	W13455 Well 66-8, 2050' <u>NWSES8T22NR40E</u>
Temp <sup>o</sup> C	16	62	62+	62+
Flow (gpm)	1200	25/air lift	75/air lift	75/air lift
pH	7.88	9.40	9.10	9.00
Cl	56.0	38.0	31.0	32.0
F	0.5	5.6	3.0	4.4
SO <sub>4</sub>	60.0	100.0	100.0	87.0
HCO <sub>3</sub>	135.0	144.0	142.0	154.0
CO <sub>3</sub>	0.0	72.0	24.0	44.0
SiO <sub>2</sub>	70.0	120.0	75.0	65.0
Na	42.0	160.0	98.0	110.0
K	6.9	21.0	14.0	14.0
Ca	47.0	6.6	9.6	8.0
Mg	14.0	2.6	16.0	14.0
Li	0.0	0.7	0.4	0.4
B	0.4	NA	NA	NA
TDS	431.8	670.0	513.0	532.8
Ec(k)	NA	NA	NA	NA
Tq SiO <sub>2</sub>	117	148	120	115
Tc SiO <sub>2</sub>	90	122	94	86
T Na-K-Ca	59	205	197	194

Table I. Continued

	W13456 Well 66-8, 2410' <u>NWSES8T22NR40E</u>	W14377 Gilbert Spring <u>SES34T21NR40E</u>	W14378 WS <u>NES2T20NR40E</u>	W14379 WS <u>NWSWS9T22NR38E</u>
Temp <sup>o</sup> C	62+	10	17	18
Flow (gpm)	100/air lift	12	25	2
pH	9.0	8.1	8.6	8.9
Cl	31.0	15.0	11.0	53.0
F	4.1	0.1	0.1	0.7
SO <sub>4</sub>	80.0	21.0	15.0	78.0
HCO <sub>3</sub>	204.0	149.0	124.0	176.0
CO <sub>3</sub>	20.0	0.0	12.0	22.0
SiO <sub>2</sub>	62.0	15.0	20.0	37.0
Na	110.0	22.0	17.0	170.0
K	14.0	0.6	0.9	3.3
Ca	6.0	43.0	37.0	4.0
Mg	18.0	7.0	7.0	1.0
Li	0.5	<0.1	<0.1	<0.1
B	NA	<0.2	<0.2	0.3
TDS	550.0	273.0	244.3	545.4
Ec(k)	NA	350.0	300.0	640.0
Tq SiO <sub>2</sub>	112	53	63	88
Tc SiO <sub>2</sub>	83	21	31	57
T Na-K-Ca	197	-2	6	116

Table I. Continued

	W14380 Shoshone Meadows W.S. <u>NESES2T22NR38E</u>	W14381 CS <u>SWSWS18T21NR39E</u>	W14382 Smooth Canyon Sp. <u>NWS10T21NR38E</u>	W14383 CS <u>SES16T25NR38E</u>
Temp <sup>o</sup> C	25	14	15	14
Flow (gpm)	1	5	ND	20
pH	8.8	8.5	8.6	8.5
Cl	44.0	27.0	58.0	69.0
F	0.6	2.0	2.0	0.2
SO <sub>4</sub>	66.0	54.0	48.0	98.0
HCO <sub>3</sub>	117.0	119.0	189.0	144.0
CO <sub>3</sub>	13.0	8.0	11.0	6.0
SiO <sub>2</sub>	38.0	91.0	38.0	15.0
Na	130.0	52.0	88.0	57.0
K	1.8	8.4	4.5	3.0
Ca	3.0	35.0	62.0	190.0
Mg	<1.0	2.0	12.0	71.0
Li	<0.1	0.2	<0.1	<0.1
B	<0.2	0.2	0.3	<0.2
TDS	417.7	398.8	512.9	653.5
Ec(k)	510.0	450.0	730.0	1300.0
Tq SiO <sub>2</sub>	89	132	89	53
Tc SiO <sub>2</sub>	59	105	59	21
T Na-K-Ca	87	74	49	17

Table I. Continued

	W14384 CS <u>NWS11T25NR39E</u>	W14385 Thompson WW <u>SENWS10T25NR1E</u>	W14386 Hess Spr. <u>SWNES29T26NR41E</u>	W14387 Red Butte WW <u>SESES26T25NR41E</u>
Temp <sup>OC</sup>	15	10	15	10
Flow (gpm)	1	500	2	1000
pH	8.5	8.6	8.9	8.7
Cl	57.0	30.0	50.0	68.0
F	5.0	0.4	0.3	0.4
SO <sub>4</sub>	68.0	25.0	43.0	41.0
HCO <sub>3</sub>	254.0	121.0	0.0	96.0
CO <sub>3</sub>	14.0	10.0	11.0	9.0
SiO <sub>2</sub>	23.0	35.0	51.0	69.0
Na	170.0	39.0	62.0	59.0
K	24.0	2.6	2.6	9.8
Ca	82.0	19.0	40.0	33.0
Mg	58.0	5.0	7.0	3.0
Li	0.4	<0.1	<0.1	<0.1
B	1.2	<0.2	0.3	<0.2
TDS	756.6	287.3	267.3	388.5
Ec(k)	1400	360.0	510.0	500.0
Tq SiO <sub>2</sub>	69	86	103	117
Tc SiO <sub>2</sub>	37	55	73	89
T Na-K-Ca	187	48	39	81

Table I. Continued

	W14388 Swanson WW <u>Center 531 T25NR41E</u>	W14397 Well 28-18, 1470' <u>SWSWS28T22NR40E</u>	W14350 Shoshone Pass WW <u>NWS32T22NR39E</u>	W14991 Hole-in-Wall WW <u>SENES2T23NR39E</u>
Temp <sup>o</sup> C	14	40	27	21
Flow (gpm)	100	50/air lift	65	3
pH	8.3	8.1	7.6	7.5
Cl	150.0	46.0	31.0	78.1
F	0.2	0.3	1.1	0.5
SO <sub>4</sub>	68.0	59.0	98.0	87.0
HCO <sub>3</sub>	106.0	78.0	206.0	120.0
CO <sub>3</sub>	0.0	0.0	0.0	0.0
SiO <sub>2</sub>	55.0	80.0	85.0	48.0
Na	52.0	69.0	77.0	78.0
K	11.0	15.0	18.0	7.7
Ca	100.0	22.0	40.0	50.0
Mg	12.0	3.8	10.0	7.8
Li	< 0.1	0.1	0.1	0.1
B	0.2	0.4	0.4	0.4
TDS	554.5	351.6	566.6	477.5
Ec(k)	880.0	445.0	689.0	NA
Tq SiO <sub>2</sub>	106	123	128	101
Tc SiO <sub>2</sub>	77	97	101	70
T Na-K-Ca	61	207	208	68



Table I. Continued

	<u>W14992</u> <u>McCoy Mine WW</u> <u>Sec9T23NR40E</u>	<u>W14993</u> <u>Edwards Cr. WW</u> <u>NWNWS3T21NR39E</u>	<u>W14994</u> <u>WW</u> <u>NES2T21NR39E</u>
Temp °C	43	15	16
Flow gpm	25	5	5
pH	7.2	8.0	7.6
Cl	24.0	39.0	26.0
F	4.2	1.3	0.8
SO <sub>4</sub>	47.0	80.0	42.0
HCO <sub>3</sub>	580.0	178.0	130.0
CO <sub>3</sub>	0.0	0.0	0.0
SiO <sub>2</sub>	40.0	80.0	61.0
Na	230.0	110.0	71.0
K	15.0	9.4	4.8
Ca	43.0	23.0	14.0
Mg	8.7	2.1	2.7
Li	0.3	0.1	0.1
B	1.3	0.6	0.3
TDS	993.5	523.5	352.7
Ec(k)	NA	NA	NA
TqSiO <sub>2</sub>	94	122	111
TcSiO <sub>2</sub>	61	97	82
TNa-K-Ca	157	95	79

Table I. Continued

	<u>W14995</u> <u>Well 25-9, 1640'</u> <u>NWSW9T22NR4OE</u>	<u>W14996</u> <u>Well 25-9, 1840'</u> <u>NWSW9T22NR4OE</u>	<u>W14997</u> <u>Well 25-9, 2000'</u> <u>NWSW9T22NR4OE</u>
Temp °C	44	48	54
Flow gpm	25/air lift	30/air lift	30/air lift
pH	8.7	8.2	8.2
Cl	29.0	34.0	45.0
F	2.9	1.7	1.0
SO <sub>4</sub>	64.0	75.0	86.0
HCO <sub>3</sub>	182.0	158.0	156.0
CO <sub>3</sub>	12.0	0.0	0.0
SiO <sub>2</sub>	17.0	25.0	35.0
Na	85.0	69.0	58.0
K	14.0	11.0	12.0
Ca	8.4	19.0	34.0
Mg	20.0	16.0	29.0
Li	0.3	0.2	0.1
B	0.8	0.5	0.4
TDS	435.4	409.4	456.5
Ec(k)	624.0	570.0	655.0
TqSiO <sub>2</sub>	64	77	89
TcSiO <sub>2</sub>	25	40	55
TNa-K-Ca	69	53	50

Table I. Continued

	W14998 Well 38-9, 550' <u>SESW9T23NR40E</u>	W14999 Well 38-9, 1200' <u>SESW9T23NR40E</u>	W15000 Well 38-9, 1300' <u>SESW9T23NR40E</u>
Temp °C	34	47	47
Flow gpm	25/air lift	115/air lift	125/air lift
pH	8.4	7.9	7.8
Cl	22.0	23.0	23.0
F	4.2	4.2	4.2
SO <sub>4</sub>	58.0	53.0	57.0
HCO <sub>3</sub>	472.0	538.0	530.0
CO <sub>3</sub>	28.0	0.0	0.0
SiO <sub>2</sub>	44.0	35.0	35.0
Na	230.0	230.0	230.0
K	18.0	16.0	16.0
Ca	24.0	33.0	35.0
Mg	13.0	11.0	12.0
Li	0.3	0.3	0.3
B	1.2	1.2	1.2
TDS	914.7	944.7	963.75
Ec(k)	1128.0	1190.0	1201.0
TqSiO <sub>2</sub>	97	89	89
TcSiO <sub>2</sub>	66	55	55
TNa-K-Ca	171	163	162

Chemically the waters appear to fall into three distinct groups (Fig. 5 and Table II). The majority of non-thermal ground waters are mixed cation-anion waters of low salinity and low  $\text{SiO}_2$  content (Type I). The thermal waters in the McCoy area fall into two groups (Fig. 5 and Table II). The thermal waters from the McCoy Mine area (Type III) are characterized by a higher sodium content (Fig. 5) and a low  $\text{Cl}/\text{HCO}_3$  (Mole) ratio (Table II).

The second groups of thermal waters (Type II) are low to intermediate in sodium content and intermediate to high in potassium content (Fig. 5). Several spring samples fall within the boundary of the Type II waters suggesting a mixing of thermal and meteoric waters. Type II waters tend to have a high  $\text{Cl}/\text{SO}_4$  (Mole) ratio (Table II); however, the waters from well 66-8 have  $\text{Cl}/\text{SO}_4$  mole ratio values in the same ranges as those from the McCoy Mine area (Table II).

The hydrological regime in the McCoy area appears to be quite complicated. Chemically, two distinct parent fluids are suggested. One parent fluid diluted with meteoric water gives rise to Type II waters and the second gives rise to the Type III waters.

In 1979 Joe Moore of the University of Utah Research Institute proposed to undertake a geochemical study of the drill cuttings from McCoy. AMAX agreed to provide Joe with a split of our samples. UURI prepared composite samples for the intervals of 0-40, 40-80, 80-120 and 120-160 feet for each shallow thermal gradient hole (Figure 6). The geochemical study was done under DOE contract DE-AC07-80ID12079. Multi-element geochemical analyses using Inductively Coupled Plasma-Atomic Emission Spectroscopy (Moore 1980) were performed on each composite sample. Preliminary analysis of the data from Joe Moore indicates that Zn, As, Pb, F and Hg show some correlation with the thermal anomaly and also with the known areas of hydrothermal alteration and mineralization. Figure 7 shows the contour map for mercury for the interval 120-160 feet. The contour pattern appears to emphasize certain structural directions and the linear trends become more pronounced with depth (Pilkington, 1980).

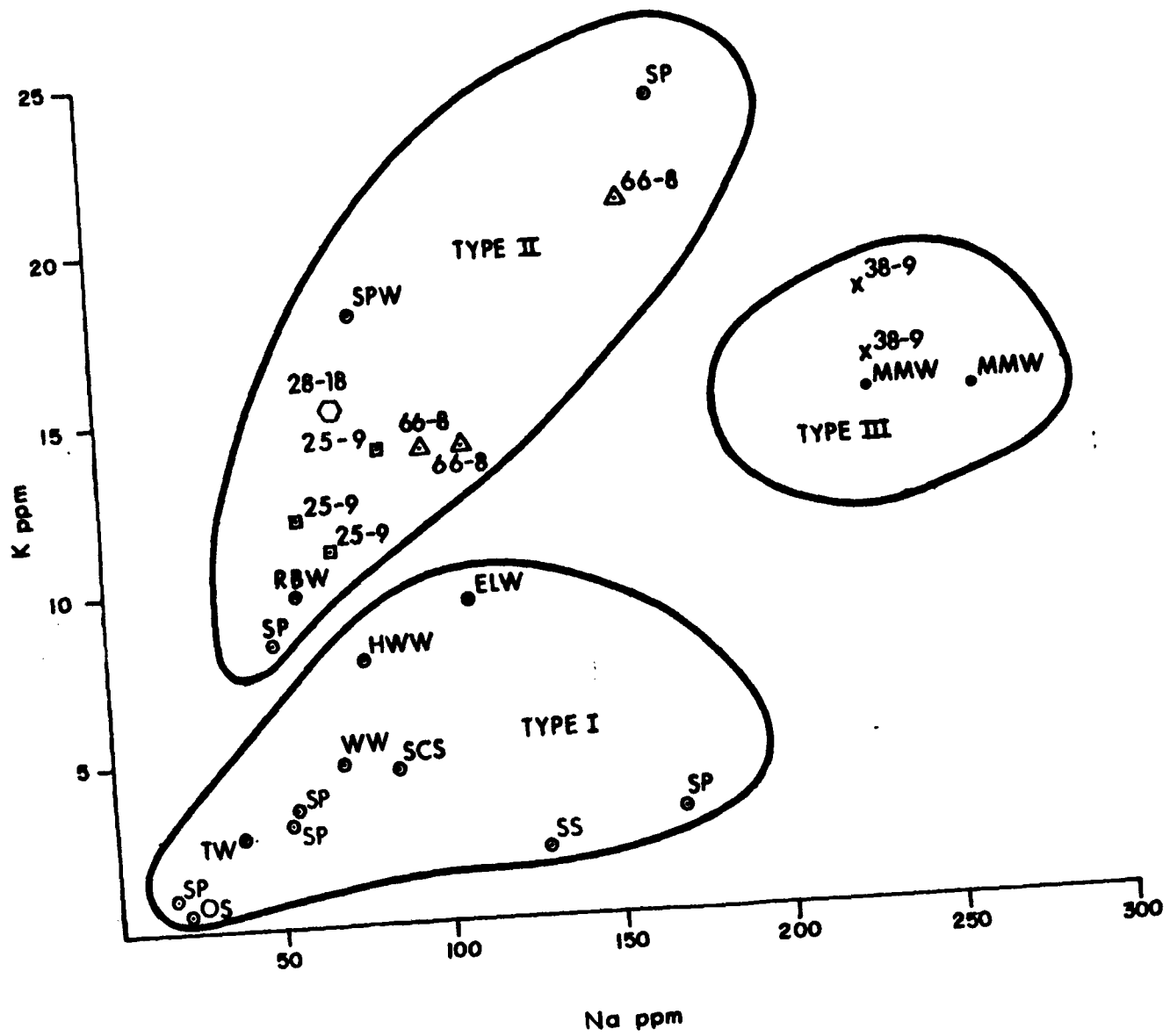
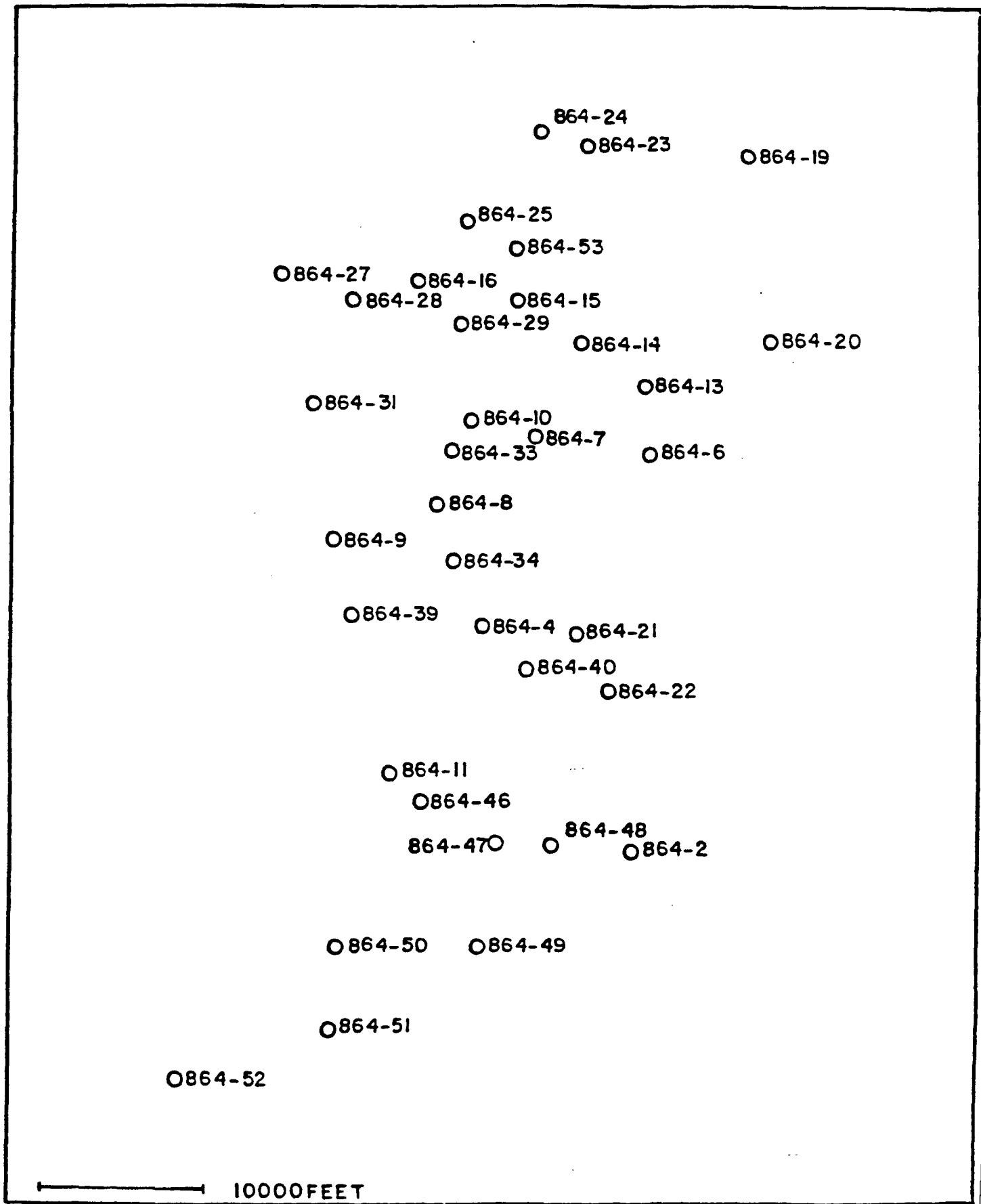

Figure 5. Na versus K in waters from the McCoy area, Nevada.

Table II. Cl/HCO<sub>3</sub> and Cl/SO<sub>4</sub> Mole Ratio Comparison for McCoy Waters

<u>Sample#</u>	<u>Area of Well #</u>	Cl/HCO <sub>3</sub> Mole Ratio	Cl/SO <sub>4</sub> Mole Ratio
W10981	McCoy Mine Well	0.06	1.10
14992	" "	0.07	1.38
14998	38-9	0.08	1.03
14999	38-9	0.07	1.18
15000	38-9	0.07	1.09
13453	66-8	0.45	1.03
13454	66-8	0.38	0.84
13456	66-8	0.26	1.05
14995	25-9	0.27	1.23
14996	25-9	0.37	1.23
14997	25-9	0.40	1.42
14750	Shoshone Pass Well	0.26	0.86
14991	Hole-in-Wall Well	1.12	2.43
14993	Edwards Creek Well	0.38	2.25
14994	Edwards Creek Valley Wl.	0.34	1.68
14397	28-18	1.01	2.11



McCOY GEOTHERMAL

DRILL HOLE MAP

Figure 6. Location map of drill holes used in geochemical study of drill cuttings.

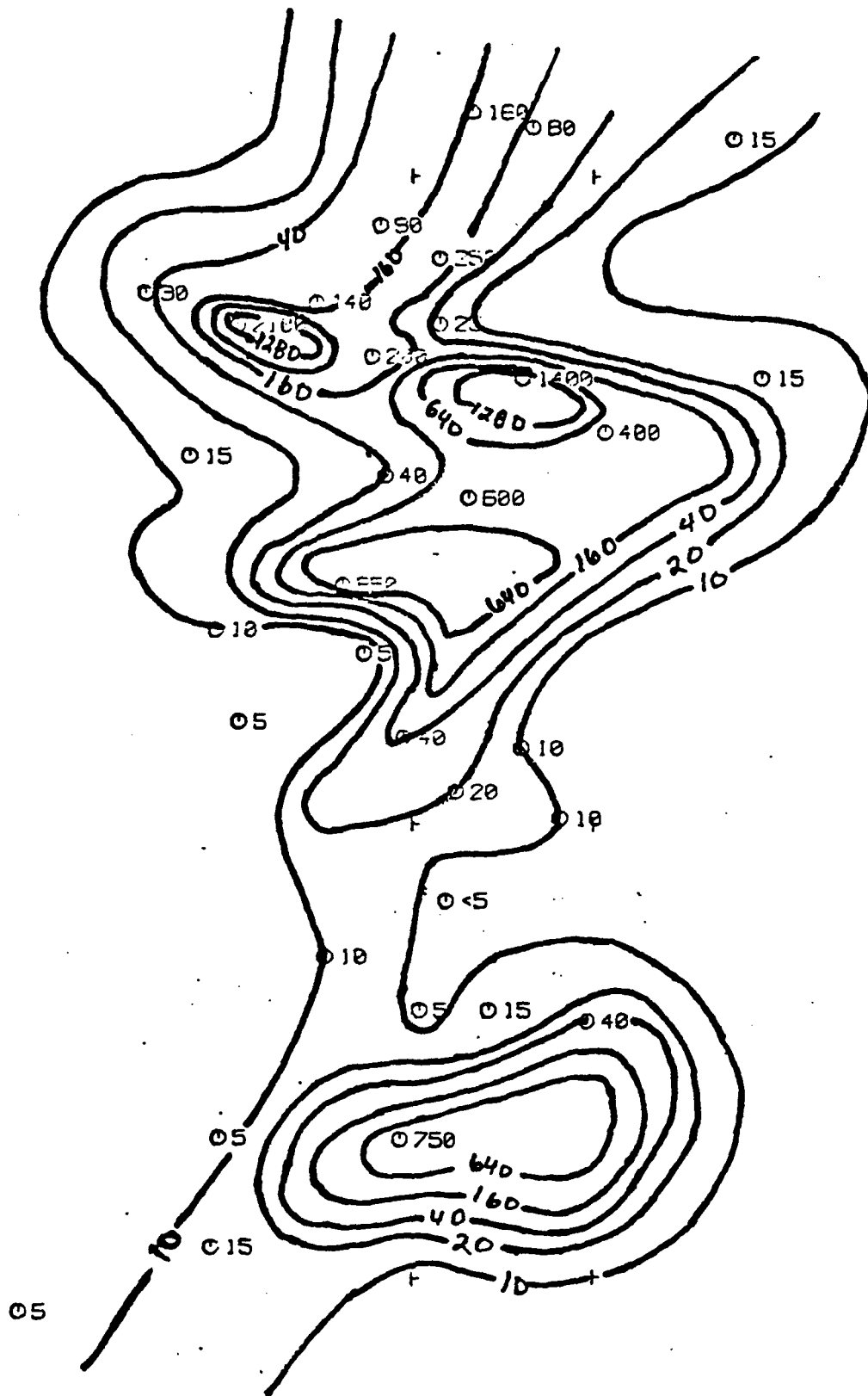

10000 FEET      FIGURE:  
 MCCOY GEOTHERMAL AREA (D)      MERCURY (PPB) 120-160 ft.  
 LANDER & CHURCHILL, NV      SAMPLE TYPE:  
    ANALYTICAL METHOD: GOLD FILM

Figure 7 Contour map of mercury in drill cuttings from 120-160 ft interval at McCoy (Pilkington, 1980).



## Geophysical Studies

The thermal anomaly at McCoy (Fig. 8) as known in 1979 was based upon thermal measurements in forty (40) shallow temperature gradient holes and five (5) existing holes. The heatflow map (Fig. 8) was based upon thermal conductivities from 12 measurements and the values for the remaining holes were estimated. A large anomaly in excess of 4 HFU has been outlined with three distinct highs, two in the north and one in the south. Additional shallow thermal gradient holes were drilled in 1981 which closed the thermal anomaly to the south. The 6.9 HFU contour extends five miles south-southeast of the southern thermal anomaly parallel to the trend shown on Figure 8.

An aeromagnetic survey of approximately 720 line-kilometers at a 1.6 km line spacing was flown by Geometrix (Olson et al., 1979). The Augusta Mountains and the New Pass Range show up as magnetic highs (Fig. 9). A v-shaped magnetic low extends to the northeast and to the southwest from the southern thermal anomaly.

A gravity survey of 340 stations was conducted by Microgeophysics Corporation and AMAX in 1979. The complete Bouguer map (Fig. 10) shows a zone of lows parallel with the magnetic lows (Fig. 9). Fred Berkman has prepared a two-layer depth profile using the U. S. Geological Survey automatic inversion program (Fig. 11).

A tensor MT survey was run by Terraphysics in February 1980 (Lange, 1980) at the McCoy property (Fig. 12). The resistivity as deduced by Lange (1980) at a depth of 5 km from the ID inversion of the MT (Te mode) is also shown. The MT section along line C-C' (Figure 13) illustrates the correlation with geology. Lange (1980) believes the MT sees a deep reservoir, (three or more kilometers) along line C-C' which is leaking fluids up the faults bounding the horst block east of well 66-8.

As a part of the Department of Energy's program to stimulate the development of geothermal resources Lawrence Berkley Laboratory (LBL) conducted a survey with the EM-60 frequency domain system over the McCoy prospect (Wilt, M. et al, 1980). The stations for the LBL survey are shown in Figure 14. The survey consisted of 19 frequency-domain electromagnetic soundings from three transmitter loops. A comparison between the EM data from LBL and the AMAX MT data is shown in Figure 15.

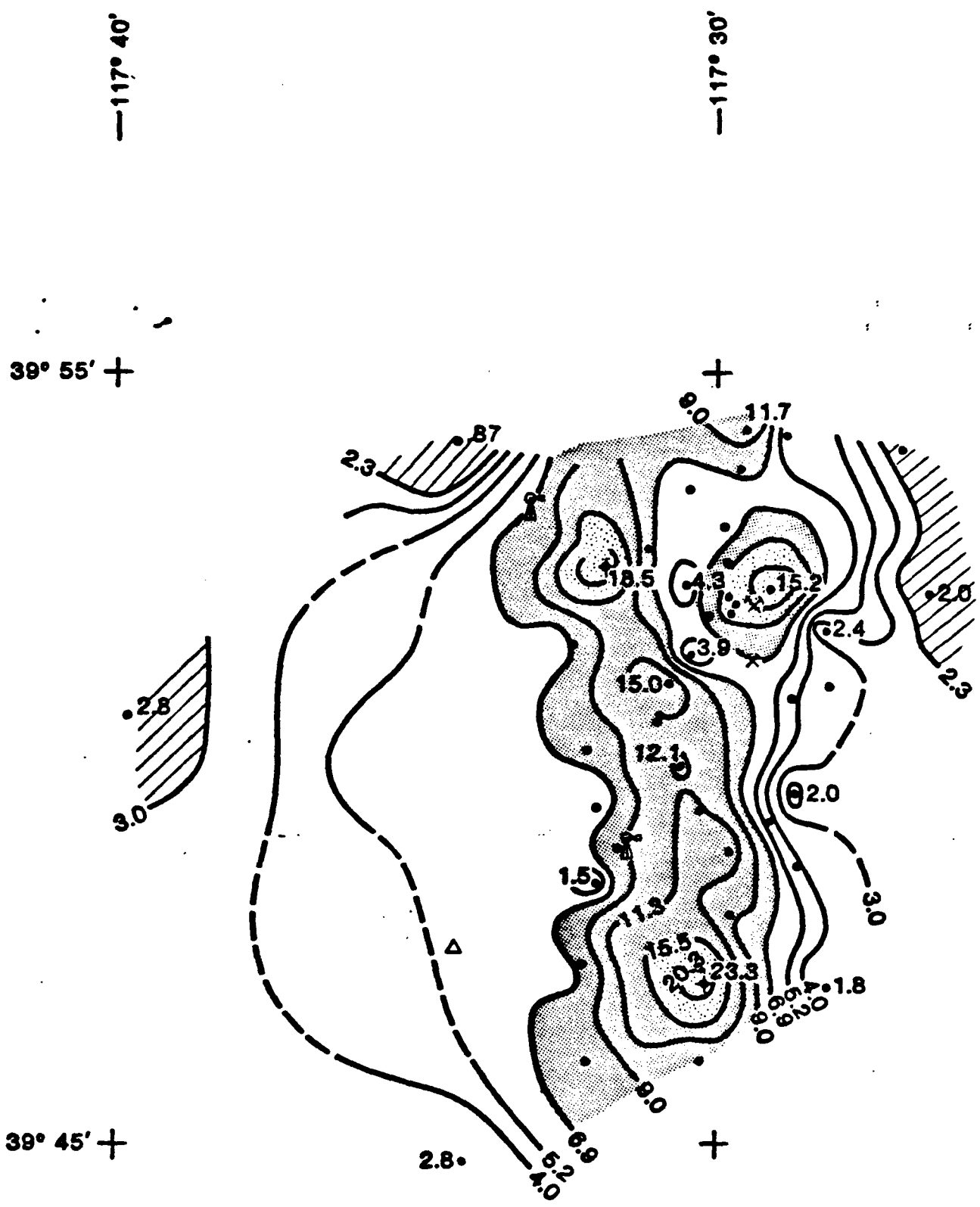
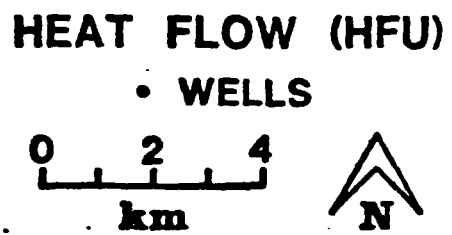
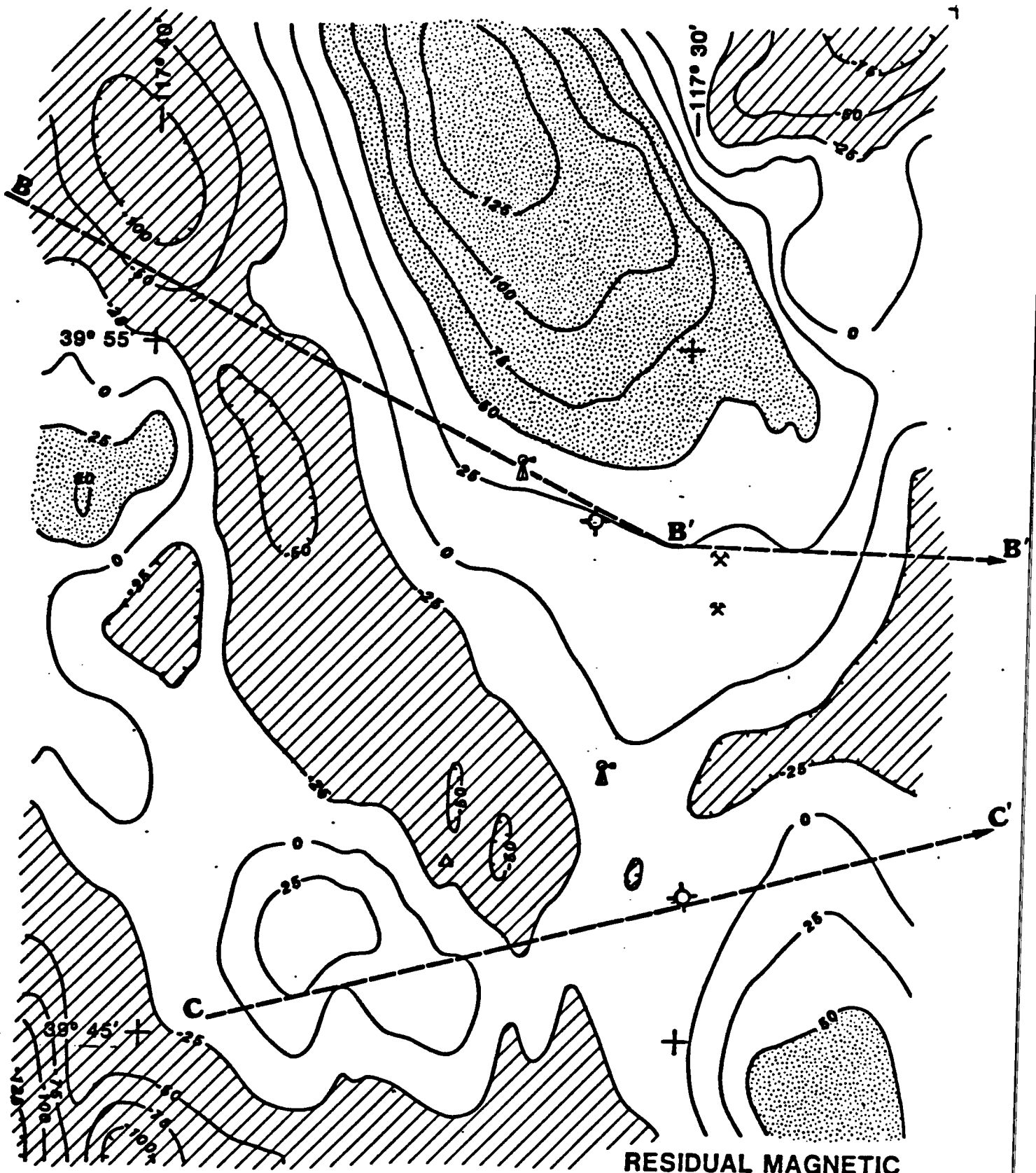

Figure 8. Heatflow map showing thermal anomaly shaded, highest heatflows stippled and lowest, striped (Lange, 1980).





RESIDUAL MAGNETIC INTENSITY

[gammas]

Figure 9. Residual aeromagnetic map. Highs are stippled; lows, striped (Lange, 1980).

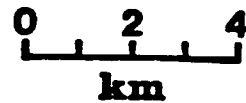

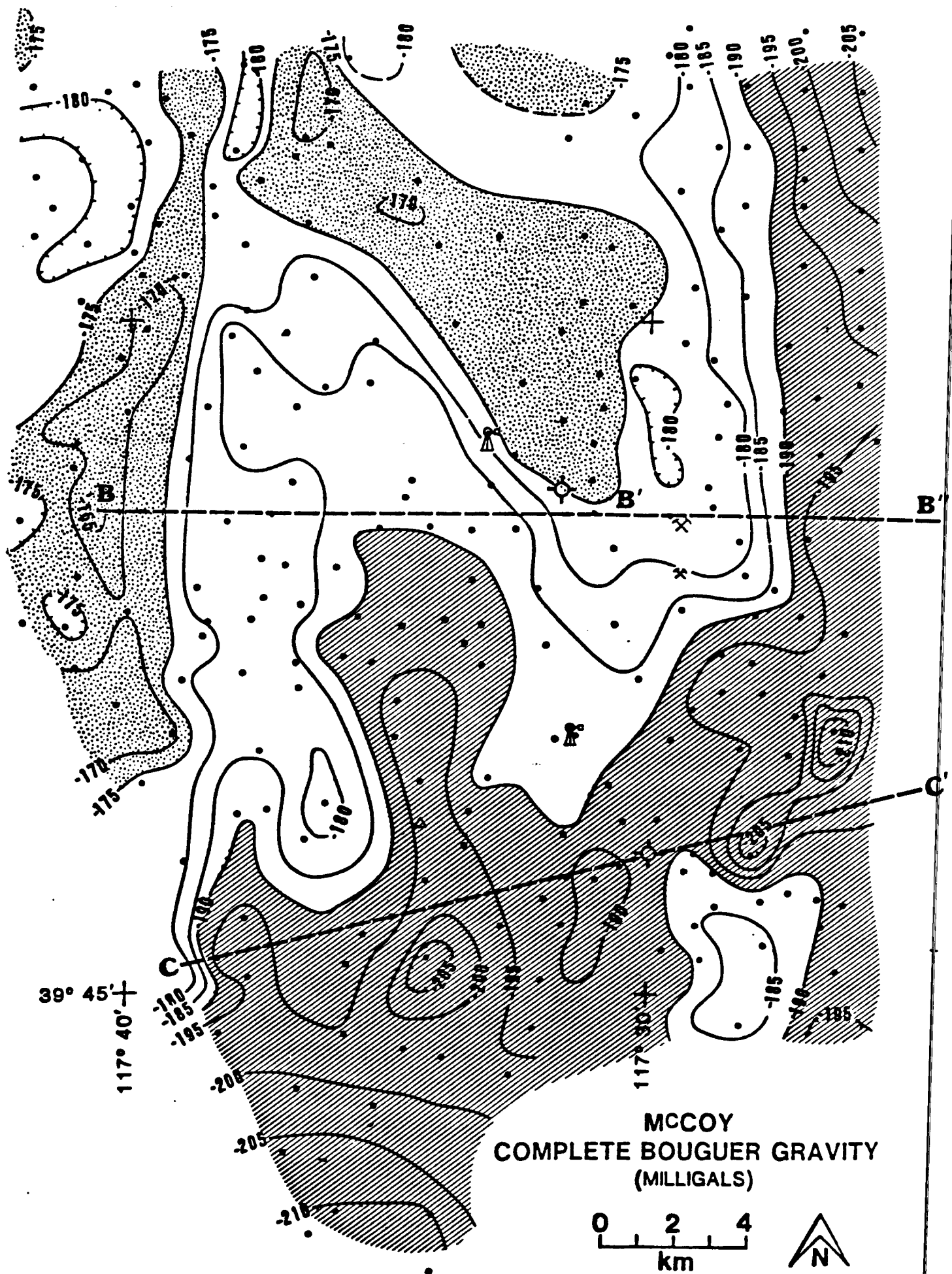
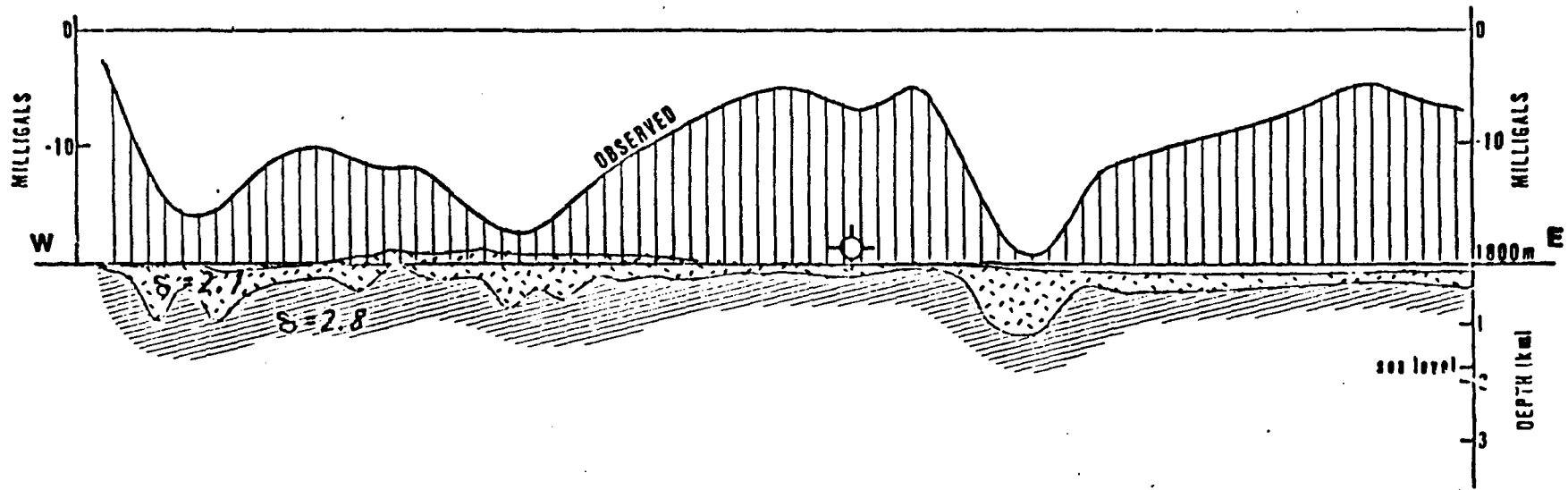

Figure 10. Complete Bouguer gravity map. Highs are stippled; lows, striped (Lange, 1980).



### RESIDUAL GRAVITY PROFILE (COMPLETE BOUGUER) AND DEPTH ANALYSIS

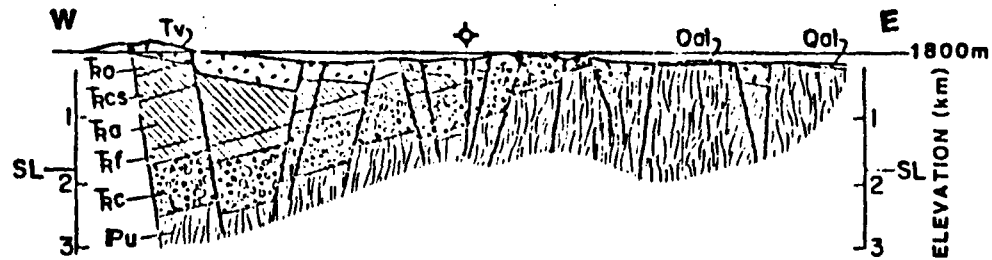

Figure 11. Gravity profile with automatic interpretation for densities (top) after Rerkman (1980) compared with geologic cross-section (bottom) after Pilkington, 1980.

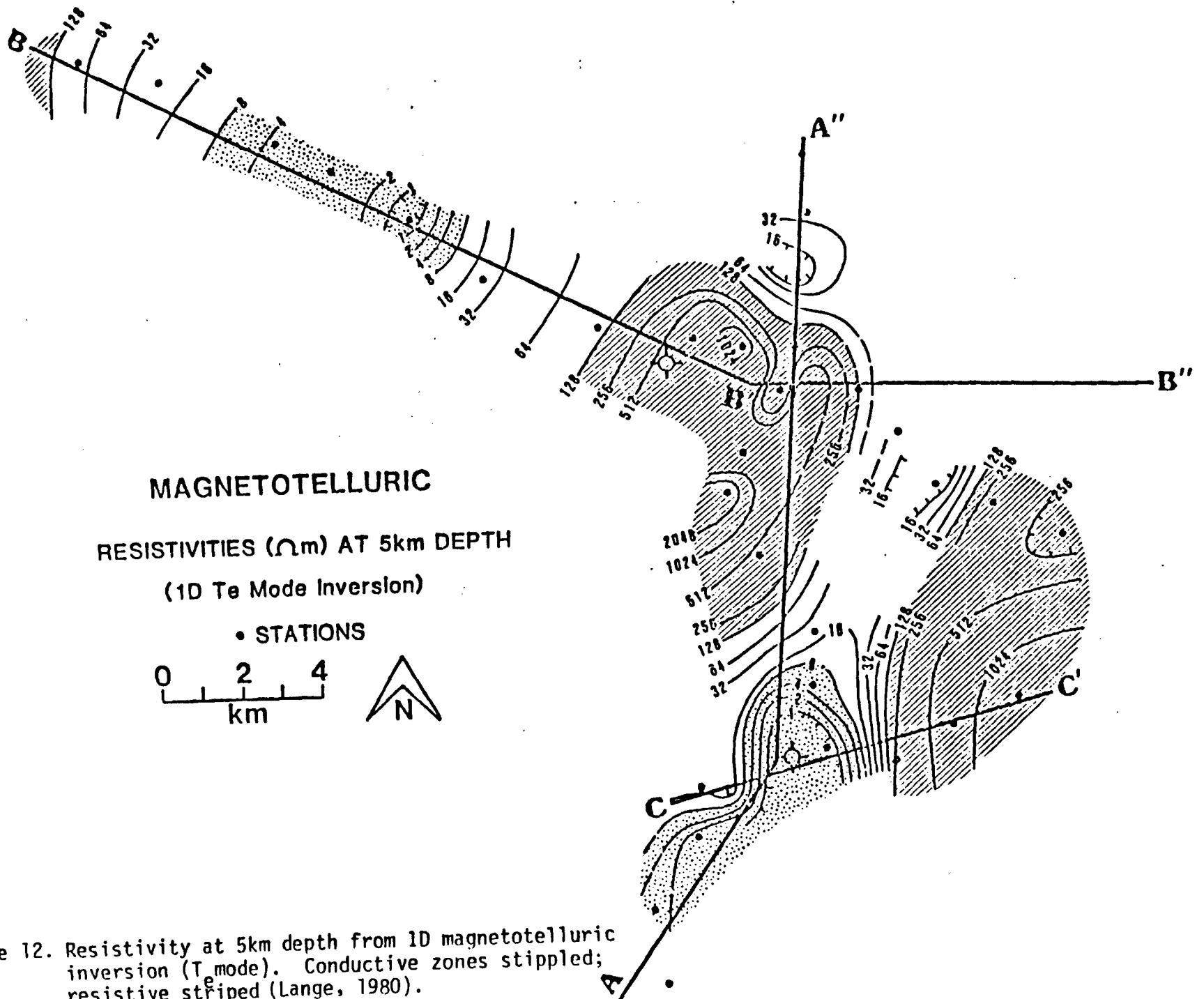
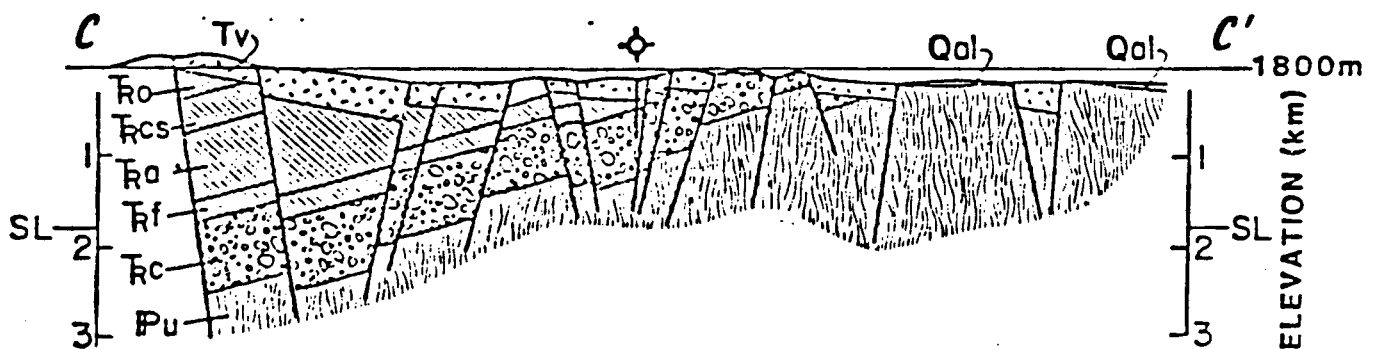
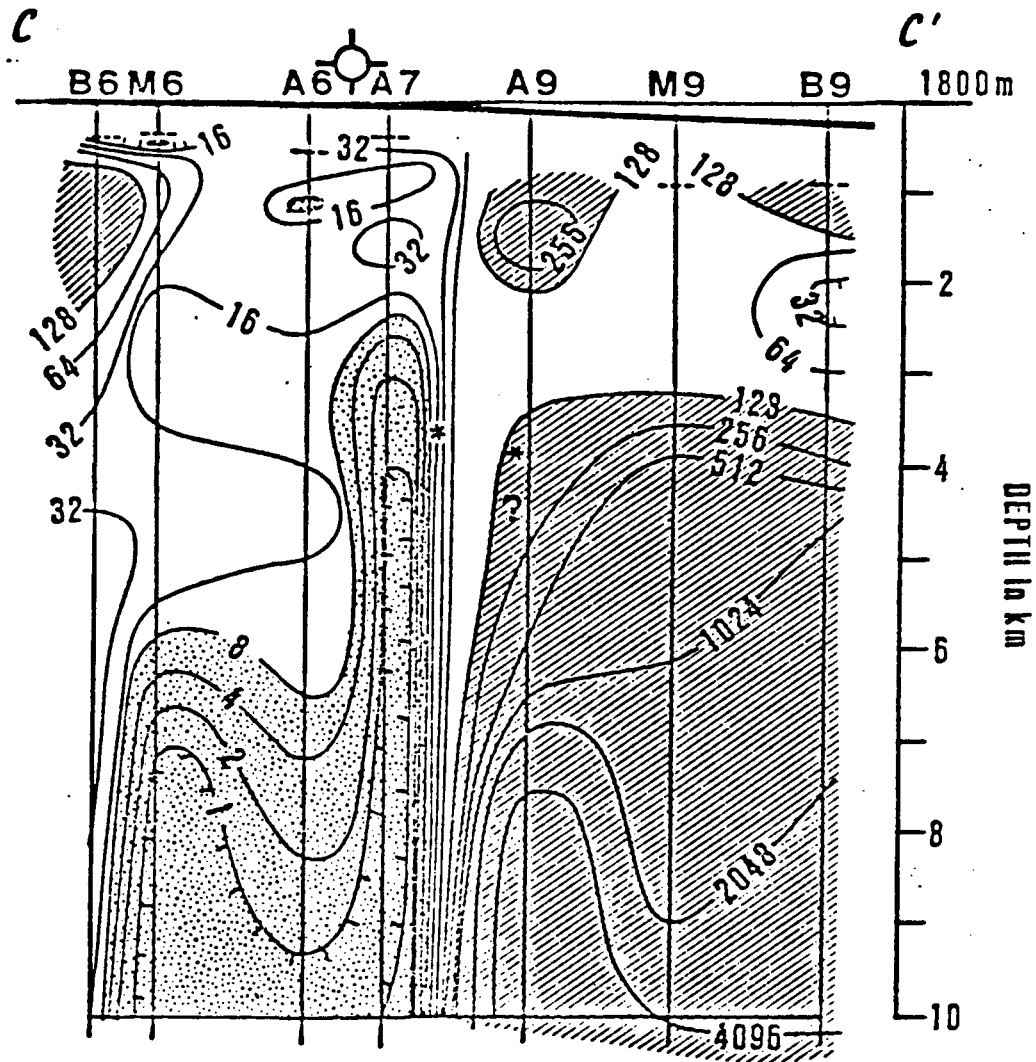
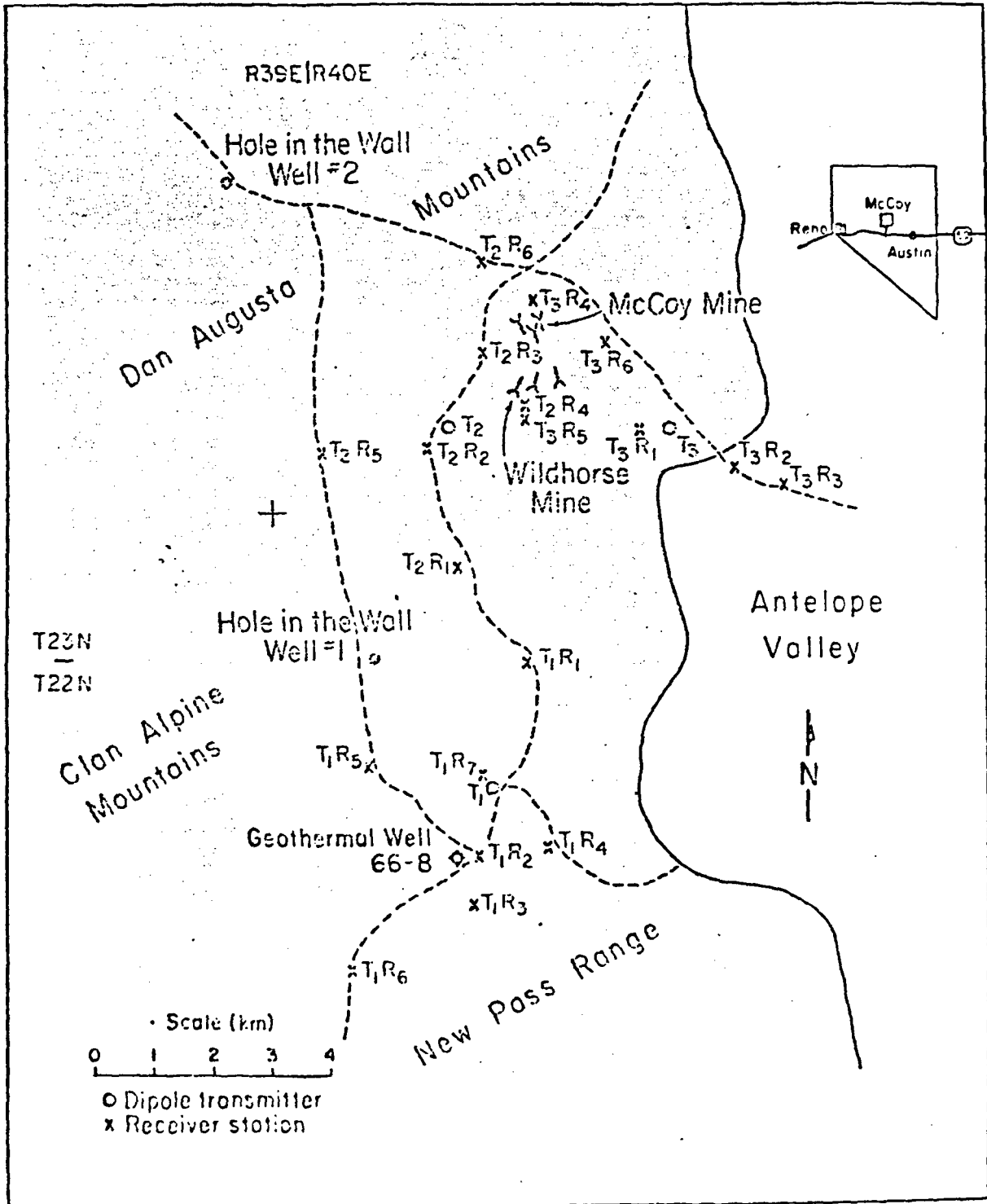

Figure 12. Resistivity at 5km depth from 1D magnetotelluric inversion ( $T_e$  mode). Conductive zones stippled; resistive striped (Lange, 1980).



## C-C' MAGNETOTELLURIC 1-D INVERSION WITH GEOLOGIC PROFILE

Figure 13. MT section ( $T_e$  mode, 1D inversion) along Line C, compared with geologic section (Lange, 1980).



xR: 60.0-2601

Figure 14. Survey location map of the McCoy prospect, after Wilt et al, 1980.



# MAGNETOTELLURIC 1-D INVERSION WITH EM PROFILE A-A'-A''

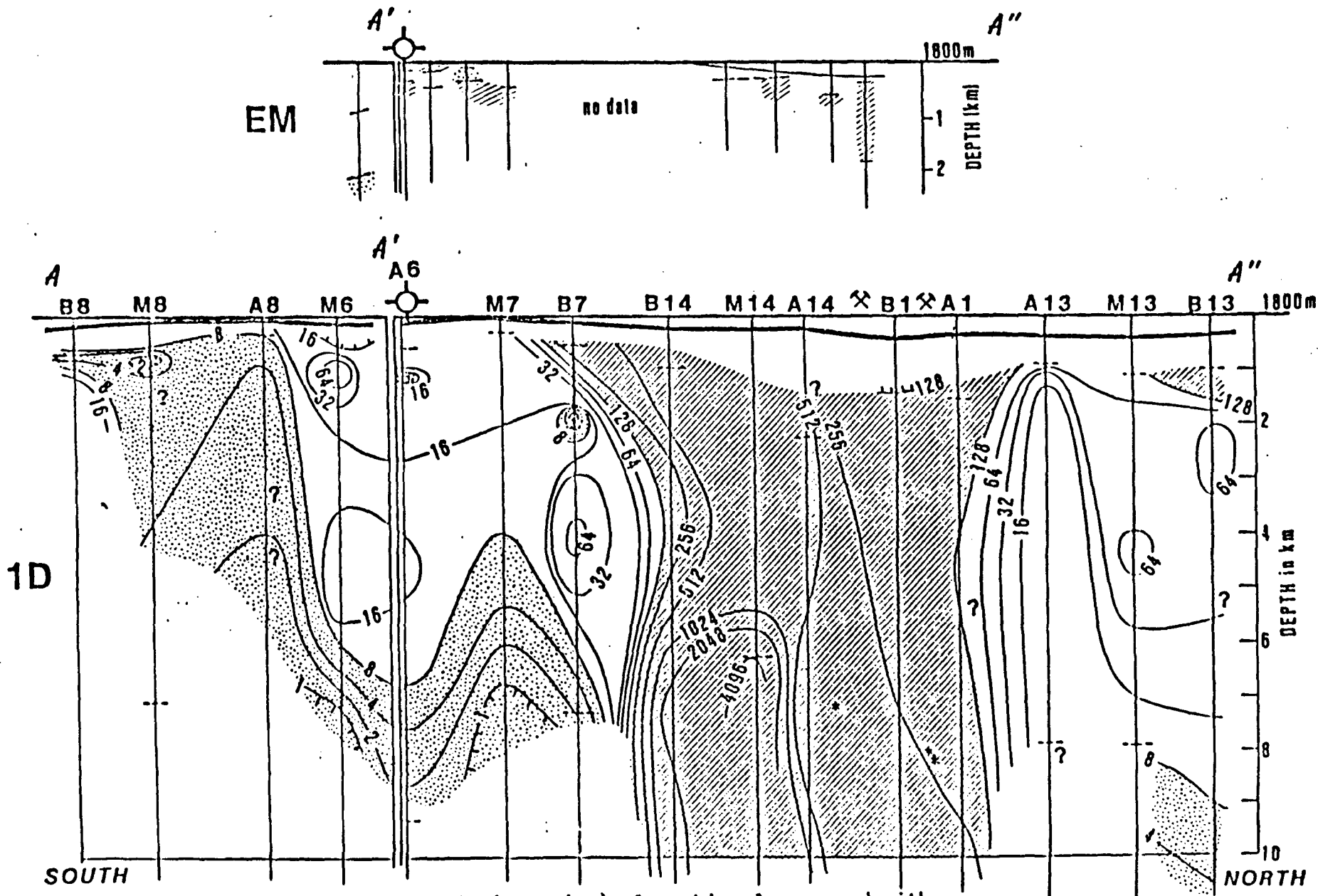

Figure 15. MT section (T mode, 1D inversion) along Line A compared with available EM data, after Lange, 1980.

Wilt et al (1980) conclude that the EM results agree well with the data gathered from well 66-8. A conductor was found at the approximate depths that boiling water was found in the well. The EM does give information on the shallow depths where MT does not give reliable results.

A resistivity survey was run by Mining Geophysical Survey, Inc. during the period February 2 to March 3, 1981. Two profiles were run along lines B-B' and C-C' of the MT survey (Pilkington, 1981). The third profile was done along an east-west line to the south (Figure 16).

The low conductivity zone, see spread 2 line C (Fig. 17), may represent the same zone of low conductivity seen in the MT and the EM-60 survey (Pilkington, 1981). The more resistive zones between the center of spread 2 and spread 1 are over the horst block of pre-Tertiary rocks. On line B the near surface resistivity responses are characteristic of inclined blocks of varying resistivity and probably relate to the block faulting. On line D (Fig. 18) the area of low resistivity on the west end of the line coincides with an increasing thickness of Tertiary volcanic rocks. The deeper zones of conductive material are probably the same as seen on the MT. The low resistivity zones may represent conduits for the thermal waters; however, interpretation is complicated by lateral migration of fluids and apparent resistivity effects.

### Exploration Drilling

The exploration drilling done at the McCoy prospect done under the DOE contract DEAC08-79ET 27010 includes fifty-two shallow thermal gradient holes three intermediate depth thermal gradient wells, and two intermediate depth exploration wells.

#### Shallow Thermal Gradient Holes

A total of fifty-two (52) shallow thermal gradient holes were drilled at the McCoy prospect. The holes range from 30 to 100 meters deep. The holes were drilled by four different contractors in 1977, 1978 and 1981 with different types of truck mounted rotary drill rigs. In general, the holes were drilled with air, using either 6 - 6 3/4-inch tri-cone roller bits or a 6-inch rotary percussion hammer to TD. The holes were completed by installing 3/4-inch PVC tubing, capped on the bottom to TD

Figure 16. Location of resistivity profile lines.

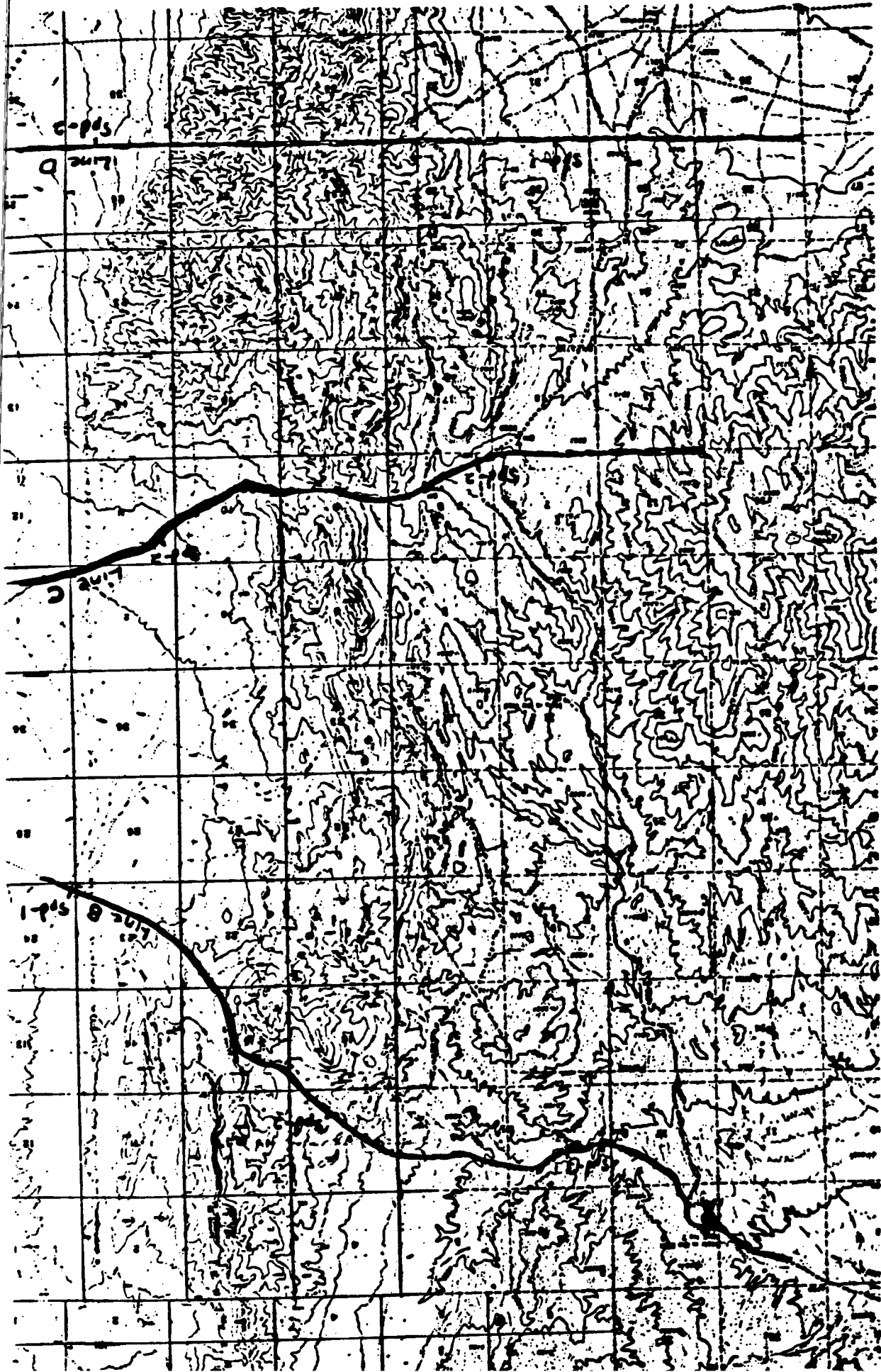

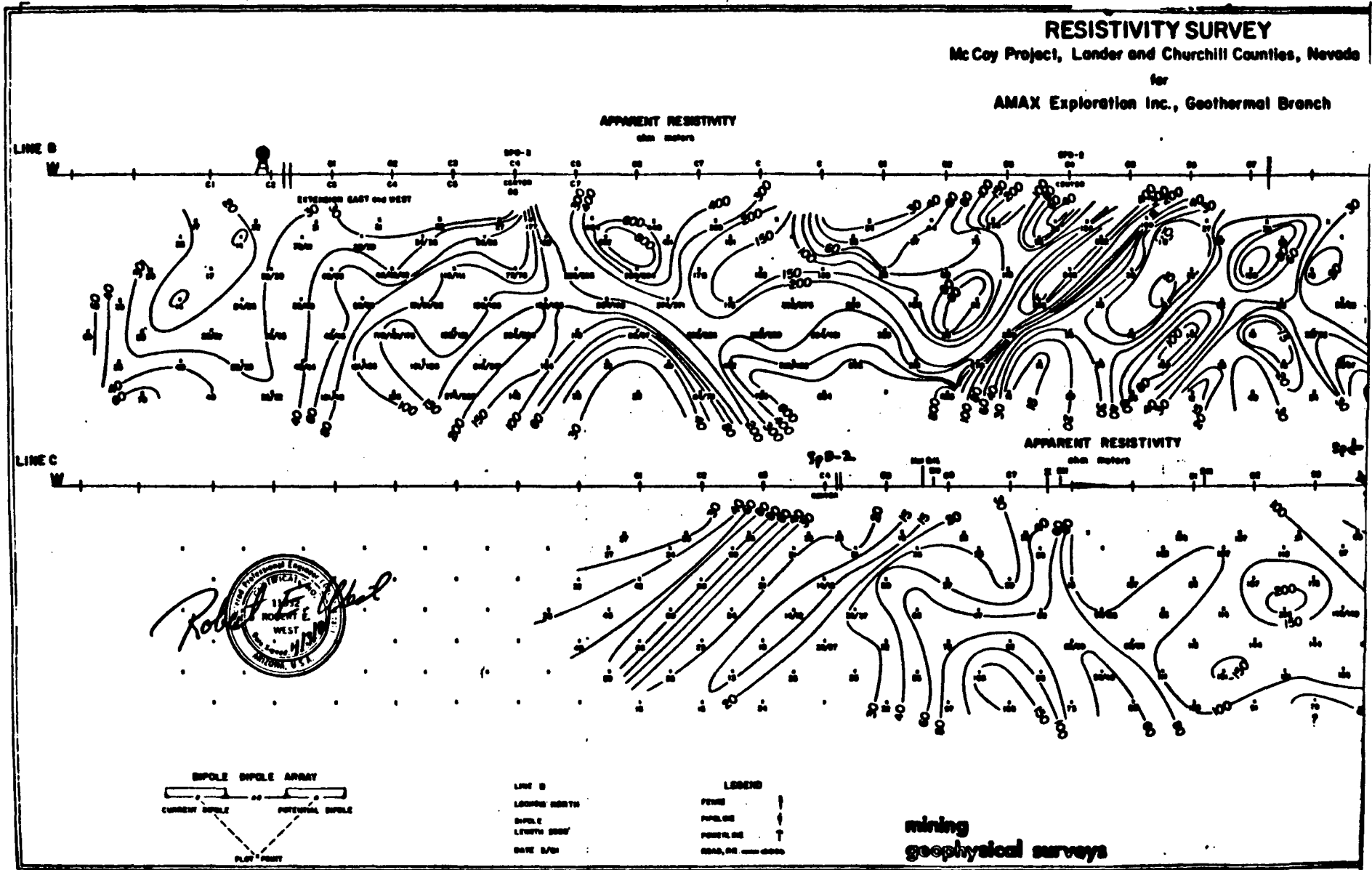

Figure 17. Resistivity survey McCoy Project, Nevada Line B and C



and then filling the PVC with water and capping the top. The annulus around the PVC pipe was back-filled with drill cuttings to within ten (10) feet of the surface and the top ten (10) feet was filled with a cement plug.

Three distinct drilling environments were encountered on the prospect: alluvial cover in Antelope Valley and Edwards Creek Valley as well as alluvial fans along the flanks of New Pass Range, the Tertiary ash-flow tuffs in the central part of the area, and the pre-Tertiary sediments in the McCoy Mine area and New Pass Range area.

No serious drilling problems were encountered in the shallow thermal gradient hole program. None of the shallow holes penetrated the groundwater table so that water was not a problem. Some lost circulation was encountered in the Tertiary volcanics as well as in the pre-Tertiary rocks; however, the lost circulation was never serious enough to cause drilling problems. Minor sloughing occurred in some of the holes causing 1-3 meters of fill before the PVC could be installed.

#### Intermediate Depth Exploration Wells

Two intermediate depth exploration wells were completed in 1980. Well 66-8 located in the NWSE Sec. 8 T22N R40E had a TD of 765 meters (2,510') and well 14-7 located in the SWNW Sec. 7 T23N R40E had a TD of 613m (2,010'). Both wells were drilled as unit wells for the McCoy Federal Geothermal Unit under a Plan of Operation (1979) approved by the U.S. Geological Survey. The generalized drilling plan for the holes is given in Table III.

Table III. Generalized Drilling Plan - McCoy Exploration Wells.

1. Move on, rig up.
2. Drill 17 1/2" hole to  $\pm$  20 feet.
3. Run 20 feet of 13 3/8" conductor pipe, cement.
4. Drill 12 1/4" hole to  $\pm$  505 feet.
5. Run 500 feet of 9 5/8" casing, cement.
6. Install BOP, test.
7. Drill 6 1/4 to 6 3/4 inch hole to TD.

8. Run logs
9. Equip hole for flow test if appropriate.
10. Equip hole as  $\Delta T$  if no production, run 3" iron pipe capped on bottom - fill with water cap top - backfill, place 10' cement plug at top.

Well 66-8 was spudded on November 4, 1979 and completed at a TD of 2,510 feet on March 29, 1980. The drilling history of well 66-8 is given in Table IV.

Table IV. Drilling History Well 66-8 McCoy Prospect, Nevada

11- 4-79	Spudded well. 12 1/4" to 90'. Air.
11- 5-79	Drilled to 520'. 6 1/2" hole. TOH.
11- 6-79	Opened hole to 12 1/4" to 100 feet. Down for repairs.
11- 7-79	Reaming 420'.
11- 8-79	Reamed to 520'. Ran 495', 8 5/8" casing.
11- 9-79	Cemented csg. WOC.
11-10-79	Ran CBL. Crew on break.
11-11-79	Crew on break.
11-12-79	Drilled out cement. Temporarily suspended opns.
12- 3-79	Pressure test csg.
12- 4-79	Washed top 17 feet of annulus. Wait on cementers.
12- 5-79	NU BOPE.
12- 6-79	NU BOPE. Get rig on ramp.
12- 7-79	Repair rig.
12- 8-79	Move rig on ramp.
12- 9-79	NU BOPE. Test BOPE - not successful.
12-10-79	Test BOPE. WOO.
12-11-79	Cement plug at 380'. WOC.
12-12-79	Test BOPE. Not successful. WOO.
12-13-79	Mix mud. Test BOPE. Not successful.
12-14-79	Wait on materials.
12-15-79	Prepared to drill ahead w/7 7/8".
12-16-79	Dropped junk in hole. No sub to go from bit to collars. Opn temporarily suspended.

1- 8-80 Built earth ramp.  
 1- 9-80 Attempted BOPE test - unsuccessful.  
 1-10-80 Reweld BOPE and test BOPE. Unsuccessful.  
 1-11-80 Blew hole dry. Remove BOPE. Fill casing w/cement. WOC.  
 1-12-80 Test csg. & wellhead - unsuccessful. Drlg out cement.  
 1-13-80 Drl'd to 200'. Test BOPE - unsuccessful.  
 1-14-80 Drlg. 220'.  
 1-15-80 Drlg. 559'.  
 1-16-80 Drlg. 589'. Junk in hole from previous personnel.  
 1-17-80 Drlg. 600'. NU BOPE.  
 1-18-80 RIH w/junk sub.' 1-19-80  
 1-19-80 CO hole. Rig up for air drlg. Drlg. 700'.  
 1-20-80 Drl'd to 715'. Lifting plug failed. Dropped string. WOT.  
 1-21-80 WOT.  
 1-22-80 Tools arrived but not operational. WOT.  
 1-23-80 WOT.  
 1-24-80 Began POH.  
 1-25-80 Drill string out of hole. Bit and subs still in hole. WOT.  
 1-26-80 Fishing.  
 1-27-80 Recovered fish. C.O. hole. Drlg. 729'.  
 1-28-80 Junk in hole slowing progress. TIH w/magnet. Drlg and reaming - 790'.  
 1-29-80 Unable to make connection @791'. Compressor not cleaning hole.  
 1-30-80 Rig released.  
 2-18-80 Rigging up new rig.  
 2-19-80 Rigging up.  
 2-20-80 Finished rigging up.  
 2-21-80 Reamed 8" hole to 680'.  
 2-22-80 Reaming 695'.  
 2-23-80 Reamed to 705'. TOH.  
 2-24-80 Ran 6 5/8" casing to 700'. Pump broke down during cementing ops. and cement not finished.  
 2-25-80 Repair pump.  
 2-26-80 Repair pump.



2-27-80 Cement casing. Cement in place 1355 hours.  
 2-28-80 NU and test BOPE.  
 2-29-80 Cleaned out cement. Drlg. 6" hole at 1,374.  
 3- 1-80 TOH for bit. Drlg. 1450'. Air.  
 3- 2-80 Crews off.  
 3- 3-80 Drlg. 1630'.  
 3- 4-80 Temp. survey. Drlg. 1690'.  
 3- 5-80 Drlg. 1850'.  
 3- 6-80 Drlg. to 1870'. TOH for new bit.  
 3- 7-80 Drlg. 1910'.  
 3- 8-80 Drlg. 2050'.  
 3- 9-80 Drlg. 2210'.  
 3-10-80 Drlg. 2330'.  
 3-11-80 Drlg. to 2350'. Trip for bit.  
 3-12-80 Deviation and temp. surveys run.  
 3-13-80 Fished for deviation tool. Recovered. Continued survey.  
 3-14-80 Finished deviation survey. Reamed to 2300' w/new bit.  
 3-15-80 Temp. survey. Drlg. 2410'.  
 3-16-80 Drlg. to 2510'. Mixing mud.  
 3-17-80 Attempted to fill hole w/mud. Spotted LCM-gel plug.  
 3-18-80 Mixed mud. Ran logs.  
 3-19-80 Finished logs. Repairs.  
 3-20-80 Tried to fill hole. Lost circulation.  
 3-21-80 Tried to fill hole. Lost circulation.  
 3-22-80 Fluid @ surface.  
 3-23-80 Crew off.  
 3-24-80 TIH for wiper run. Lost circulation @790'.  
 3-25-80 Finished trip in hole. Attempted deviation survey but tool  
 stuck. Tried to circulate, bit is plugged.  
 3-26-80 TOH. Waiting on LCM.  
 3-27-80 Ran deviation survey. Spotted LCM plug. Lost circulation.  
 3-28-80 Made wiper run and attempted to get circulation. Prepare  
 to run tubing.  
 3-29-80 Ran tubing. Released rig. Suspended as observation hole.

Well 66-8 was drilled with air to final TD. The first water entry was at 1,630 feet, with the well making about 25 gpm/air lift. Numerous hot water entries were encountered from 1,630 to 2,050 feet where flow had increased to approximately 75 gpm/air lift. The final water entry was noted at a depth of 2,410 feet when the flow increased to about 100 gpm/air lift. After reaching TD the well was conditioned for logging by mixing mud and circulating. During mud circulation the hole started losing fluids. Two days were spent trying to condition hole with LCM without success and the mud level continued to drop while Welex ran Dual Induction, Compensated Density, and Compensated Acoustic Velocity Logs (Table V). The well was completed as a thermal gradient well (Fig. 19). The drilling mud continued to flow out of hole and the temperature logs indicate the water from the 1,630 foot entry may flow down the hole and out through one of the lost circulation zones near the bottom of the hole.

Table V. Logging History for Well 66-8, McCoy Prospect, Nevada.

<u>Date</u>	<u>Type of Log*</u>	<u>Logged Interval</u>	<u>Total Depth</u>
18 March 1980	Dual Ind. Guard	700-2490'	2510'
18 March 1980	Comp. Acoustic Velocity	700-2478'	2510'
18 March 1980	Gamma Ray	700-2478'	2510'
18 March 1980	Caliper Log	700-2478'	2510'
18 March 1980	Comp. Density (neutron)	700-2362'	2510'
31 June 1980	Temperature	656-2477'	2510'

Well 14-7 was spudded on February 28, 1980 and completed at a final TD of 2,010 feet on May 25, 1980. The drilling history of well 14-7 is given in Table VI.

Table VI. Drilling History Well 14-7, McCoy Prospect, Nevada.

2-28-80	Spudded well. 9 7/8" hole. Air drilling.
2-29-80	Drld. to 48'. Preparing to ream to 16".
3- 1-80	Reamed to 25'. Repairing downhole hammer.
3- 2-80	Waiting on crews. Opns temporarily suspended.

\*Reproductions of log are available from: Rocky Mtn. Well Log Service,  
P. O. Box 3150, Denver, Colorado 80201, (303)825-2181.

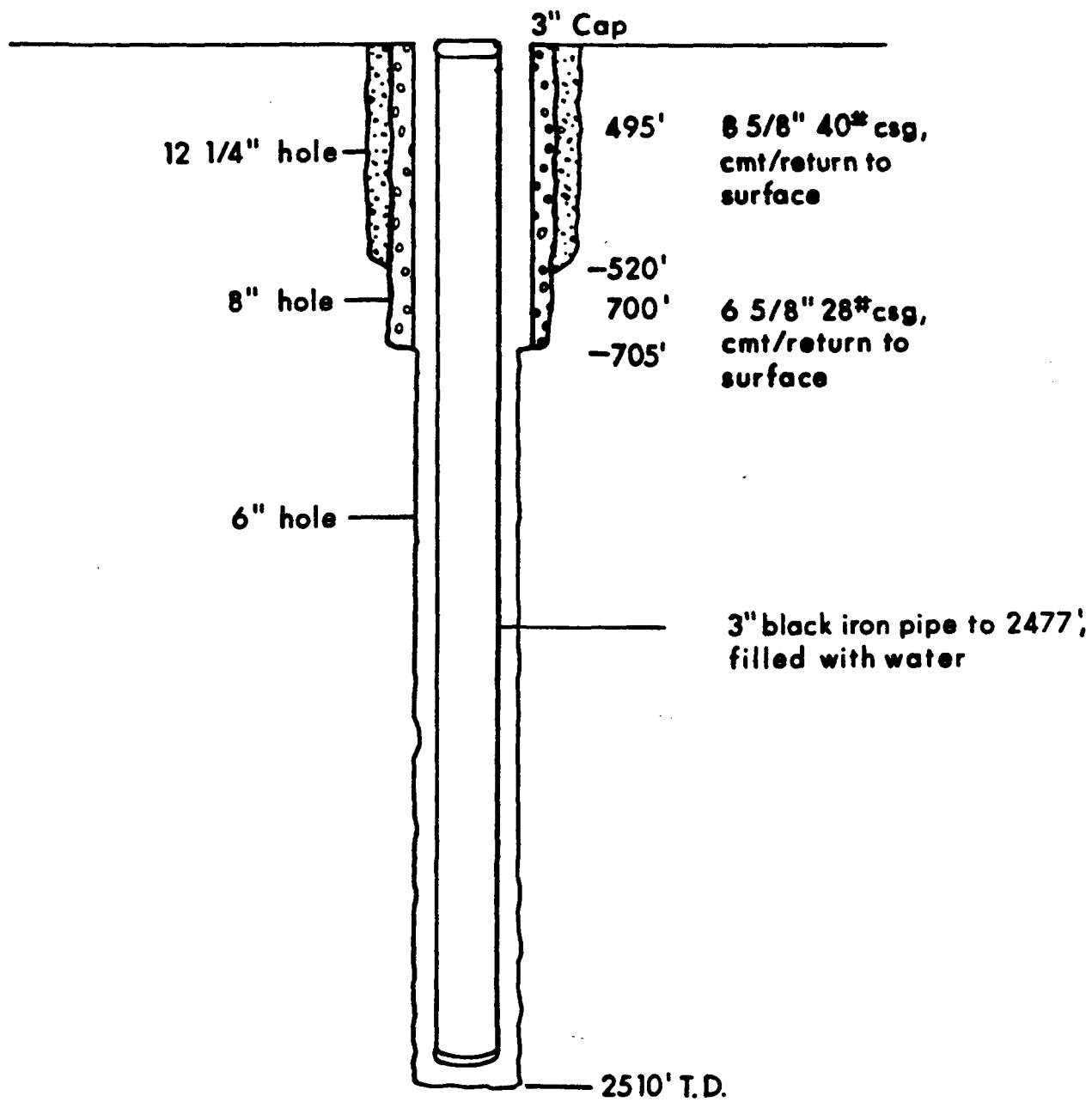

Figure 19 - WELL COMPLETION SCHEMATIC DIAGRAM FOR 66-8

3-22-80 Reamed to 48'.  
 3-23-80 No activity.  
 3-24-80 No activity.  
 3-25-80 Opns temporarily suspended.  
 3-26-80 Ran 40' 13 5/8" csg. Welded joints.  
 3-27-80 Down for repairs.  
 3-28-80 Finished running csg. 13 5/8" @ 58'. Cemented.  
 3-29-80 Rigged up blooie line.  
 3-30-80 No activity.  
 3-31-80 Moved off rig #2. NIRI #1.  
 4- 1-80 Finished rigging up. Drld. 12 1/4" to 70'.  
 4- 2-80 Drlg. 150'. Using foam.  
 4- 3-80 Drlg. 270'.  
 4- 4-80 Drld. to 355'. Hammer broke. TOH. Fishing.  
 4 5-80 Fishing.  
 4- 6-80 No activity.  
 4- 7-80 Recovered some junk. Fishing for bit.  
 4- 8-80 Fishing for bit.  
 4- 9-80 WOT.  
 4-10-80 WOT.  
 4-11-80 Fished for bit. Building new fishing tool.  
 4-12-80 Recovered bit and some other mat'l. Fishing for spring and remaining ring.  
 4-13-80 Recovered remaining junk. Drld. to 505'. Lost returns 409-426'. Then partial returns below 470'.  
 4-14-80 Fill @ 426'. CO fill.  
 4-15-80 Ran 495', 8 5/8" csg.  
 4-16-80 Attempted to cement csg. below cavity and top job above cavity. Plug did not seat. Top job ran out of cement before reaching surface.  
 4-17-80 Cemented shoe again. Finished top job.  
 4-18-80 NU BOPE. USGS witnessed test. Began 24 hr. opns.  
 4-19-80 Drlg. 840'. 6 1/2" hole.  
 4-20-80 Drld. to 1140'. Partial returns. Stuck pipe. Recovered 20'.

4-21-80 Recovered add'l. 15 ft.  
 4-22-80 Parted string.  
 4-23-80 WOT  
 5- 2-80 TIH - washed over fish.  
 5- 3-80 Recovered portion fish. Fishing.  
 5- 4-80 TOH w/fish.  
 5- 5-80 Mixed mud w/LCM.  
 5- 6-80 Mixed LCM.  
 5- 7-80 Drld. to 1145'. No returns.  
 5- 8-80 Drld. to 1195'. No returns. Waiting on water.  
 5- 9-80 Drld. to 1230'. Waited 8 hrs. on water.  
 5-10-80 Drld. to 1340'. Wait on water.  
 5-11-80 Shut down due to weather.  
 5-15-80 Drld. to 1410'. No returns.  
 5-16-80 Drld. to 1470'. Wait on water.  
 5-17-80 Drld. to 1610'. No returns. Wait on water.  
 5-18-80 Drld. to 1730'. No returns. Wait on water.  
 5-19-80 Drld. to 1860'. No returns. Wait on water.  
 5-20-80 Drld. to 2010'. No returns.  
 5-21-80 POH. Stuck pipe @ 470'. Wiped hole from 440-470. Tried to log but couldn't get past 730'.  
 5-22-80 Wiped hole.  
 5-23-80 Logging.  
 5-24-80 Ran 3" pipe.  
 5-25-80 Finished running 3" pipe. Suspended as observation hole. Rig released.

Well 14-7 was drilled to a depth of 1,140 feet on air. A water entry occurred at about 570 feet with a flow of about 100 gpm/air lift. Below the water entry encountered several lost circulation zones and from 940 to 1,140 feet drilled with no returns until drill pipe stuck when cuttings fell in when making a connection. After recovering drill pipe attempted to regain circulation with mud and LCM without success. Drilled ahead with mud and no returns. The mud seemed to float the cuttings back into the lost circulation zones. Mud loss averaged about

100 gal./foot drilled. Final TD of 2,010 feet was reached with no further problems other than some standby time waiting on water. Flushed hole with 6,500 gallons of mud and Welex ran logs (Table VII). The well was completed as a thermal gradient well (Fig. 20). The temperature logs indicate water from the water entry at about 570 feet may flow down the hole and out lost circulation zones near the bottom of the hole.

Table VII. Logging History for Well 14-7, McCoy Prospect, Nevada.

<u>Date</u>	<u>Type of Log</u>	<u>Logged Interval</u>	<u>Total Depth</u>
21 May 1980	Dual Induction	505-1979'	2010'
21 May 1980	Comp. Acoustic Velocity	505-1964'	2010'
21 May 1980	Caliper Log	505-1964'	2010'
21 May 1980	Comp. Density Log	505-1962'	2010'
21 May 1980	Gamma Ray	505-1962'	2010'
30 June 1980	Temperature	82-1935'	2010'

Several problems developed during the drilling of the intermediate depth geothermal exploration wells. The actual drill rig capacity often proves to be much less than the rated capacity in terms of torque, drawworks and compressor capability. As more exploration companies become involved in drilling intermediate depth wells, 1,000 to 4,000 feet, perhaps the drilling contractors will acquire truck mounted rigs with enough additional capacity to handle the difficult drilling conditions encountered. Another problem unique to the intermediate depth exploration wells is the availability of service companies set up to log such holes, that is we need smaller tools on smaller trucks. Logging with conventional oil field equipment can add as much as 10 percent to the cost of the well compared to a cost of approximately 1 percent in the oil patch. Many times when the logging company arrives on a remote site some of the tools will not operate properly in a geothermal environment and the unit will not have backup tools or components with them. Finally, in the northern Basin and Range area winter drilling will add greatly to the costs since most access roads will of necessity be of the limited maintenance BLM type and will not stand up to much traffic in winter weather.

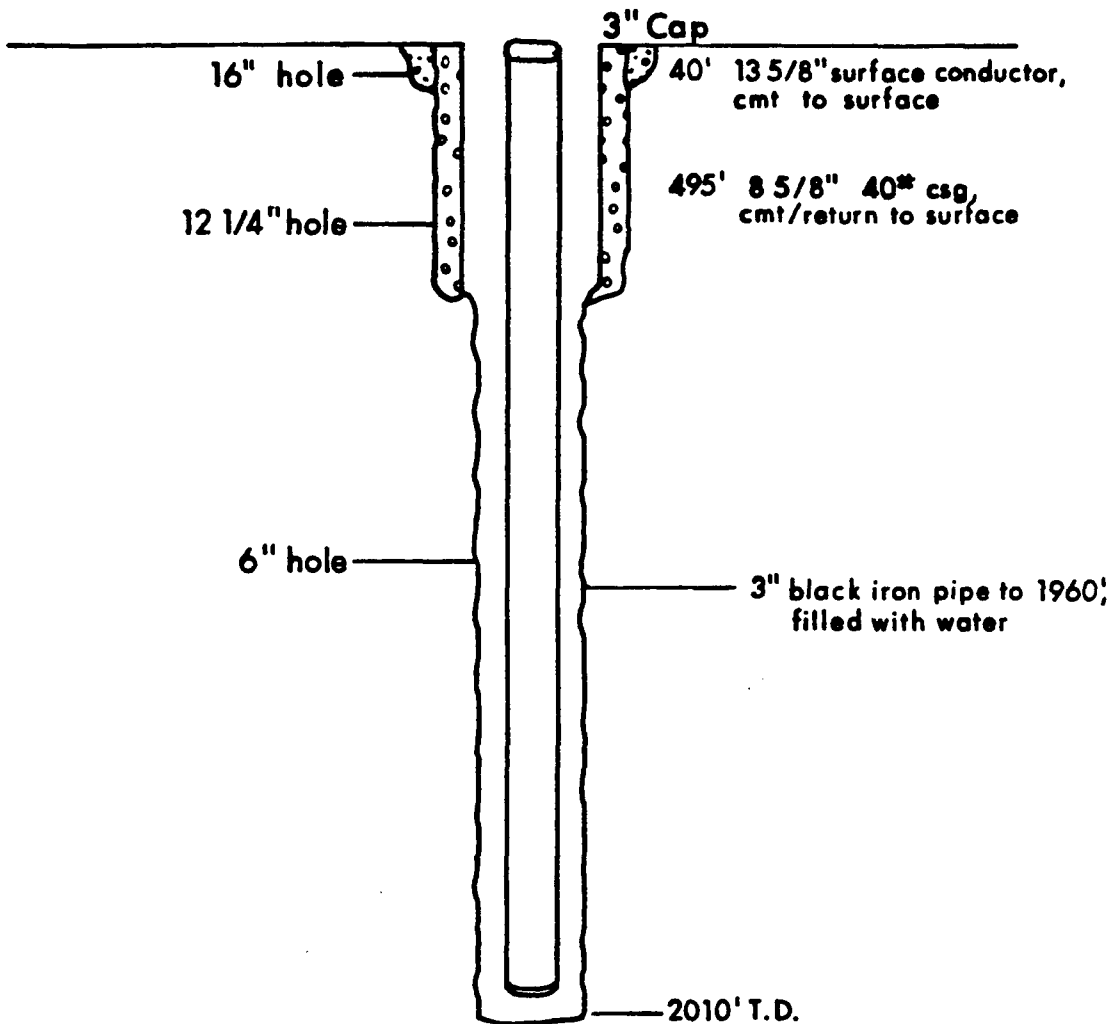

Figure 20 - WELL COMPLETION SCHEMATIC DIAGRAM FOR 14-7

## Intermediate Depth Thermal Gradient Wells

Three intermediate depth thermal gradient wells were completed on the McCoy prospect. Well 25-9 located in the NWSW Sec 9 T22N R40E had a TD of 610 meters (2,000'), well 38-9 located in the SESW Sec 9 T23N R40E reached a TD of 620 meters (2,040') and well 28-18 located in the SWSW Sec 18 T22N R40E had a TD of 1,948 feet.

The intermediate depth wells were drilled as unit wells for the McCoy Federal Geothermal Unit under a Plan of Exploration (1980) approved by the U. S. Geological Survey. The generalized drilling plan for the holes was:

1. Move on and rig up.
2. Drill 17-1/2" hole to 20 feet.
3. Run 20 feet surface conductor.
4. Drill 12-1/2" hole to 10% of TD.
5. Run 9 5/8" casing, cement.
6. Install BOP test.
7. Drill 8-5/8" hole to TD.
8. Run electric logs.
9. Run 2 3/8" tubing, fill with water.
10. Cement top 10 feet of annulus.
11. Install gate valve on top of tubing.

Well 25-9 was spudded on March 26, 1981 and reached the final TD of 2,000' on May 2, 1981. The drilling history of well 25-9 is given in Table VIII.

Table VIII. Drilling History Well 25-9 McCoy Prospect, Nevada.

3-26-81	Rig up, spud well drill 17 1/2" hole to 22, set 22' 14" conductor cmt, drld. 85' 12 1/2" hammer.
3-27-81	Shut down, weather.
3-28-81	Shut down, weather.



3-29-81 Drlg. 262'.  
 3-30-81 Set 9 5/8" csg. to 220', repair rig.  
 3-31-81 Repairs.  
 4- 1-81 Set 9 5/8" csg. to 262' cmt/no return to surface.  
 4- 2-81 Cmt. down annulus, install BOP.  
 4- 3-81 BOP test unsuccessful, standby.  
 4- 4-81 Replacement BOP install, tested, failed.  
 4 5-81 Standby.  
 4- 6-81 BOP arrive 1800 hrs install, wait on USGS.  
 4- 7-81 BOP test at 0400 hrs, passed, mud pump down for repair.  
 4- 8-81 Repairs, drlg.740'.  
 4- 9-81 Drlg. 1110', temp. survey.  
 4-10-81 Drlg. 1360', broken grad. lost circ.  
 4-11-81 Drlg. 1520', repair compressor.  
 4-12-81 Drlg. 1630', TOH for bit.  
 4-13-81 Drlg. 1742', TOH for bit.  
 4-14-81 Drlg. 2000'. Water sample @ 1840 and 2000'.  
 4-15-81 TOH, hydraulic down.  
 4-16-81 Repair, TOH.  
 4-17-81 Well logs to 1660' where bridged TOH, repairs.  
 4-18-81 Repairs, TIH clean, TOH.  
 4-19-81 Holiday.  
 4-20-81 Holiday.  
 4-21-81 Run 2 3/8" tubing 1650' bridge.  
 4-22-81 Run 2 3/8" tubing to 1680', tubing twist off @ 1200', fish.  
 4-23-81 Fish, pull tubing, drop 40' down hole.  
 4-24-81 Standby, waiting on tools.  
 4-25-81 Working on tools.  
 4-26-81 Working on tools.  
 4-27-81 Fish out 40' section, fish main string.  
 4-28-81 Pull tubing, TIH to 1600'.  
 4-29-81 Clean hole 1600' to 1650', plug bit, TOH, TIH.  
 4-30-81 Clean hole to 2000', TOH.  
 5- 1-81 Run 2 3/8" tubing to 2000', fill with water.  
 5- 2-81 Rig down.

Well 25-9 was drilled to TD on air. Warm water entries were noted at 1,640, 1,840 and 2,000 feet. Sloughing problems between 1,620 and 1,656 feet caused problems when Microgeophysics attempted to log the well (Table IX). The hole was cleaned and completed as a temperature gradient well according to the drilling plan (Fig. 21).

Table IX. Logging History for Well 25-9, McCoy Prospect, Nevada.

<u>Date</u>	<u>Type of Log</u>	<u>Logged Interval</u>	<u>Total Depth</u>
17 April 1981	Gamma Ray	0 -1639'	2000'
17 April 1981	SP	1467-1639'	2000'
17 April 1981	Resistivity	1474-1639'	2000'
5 August 1981	Temperature	295-1961'	2000'

Well 38-9 was spudded on April 16, 1981 and was completed to a final TD of 2,038 feet on May 24, 1981. The drilling history for well 38-9 is given in Table X. Well 38-9 was drilled with air to 1,400 feet where water flooded out the hammer. After running casing, picked up more water and at 1,430 feet switched over to mud to complete the hole. Warm waters were encountered at depths of 550 feet (25 gpm/air lift) 1,200 feet (115 gpm/air lift), 1,300 feet (125 gpm/air lift) and 1,430 (300 gpm/air lift). The hole was logged by Microgeophysics (Table XI) on May 25, 1981. Well 38-9 was completed as a temperature gradient hole (Fig. 22).

Table X. Drilling History Well 38-9, McCoy Prospect, Nevada.

16 April 1981	Rig up, spud well, drld. to 21', set 14" csg., cement.
17 April 1981	Site work.
18 April 1981	Holiday.
19 April 1981	Holiday.
20 April 1981	Drlg. 12 1/4" hole to 280' hole caved, string stuck.
21 April 1981	Drlg. suspended - work for big rig.
4 May 1981	Move equipment to site.
5 May 1981	Start clean hole around rods. POH with 40' of rods.
6 May 1981	Tools free, drlg. 300', POH, cleaned hole, run 100' 9 5/8" csg.

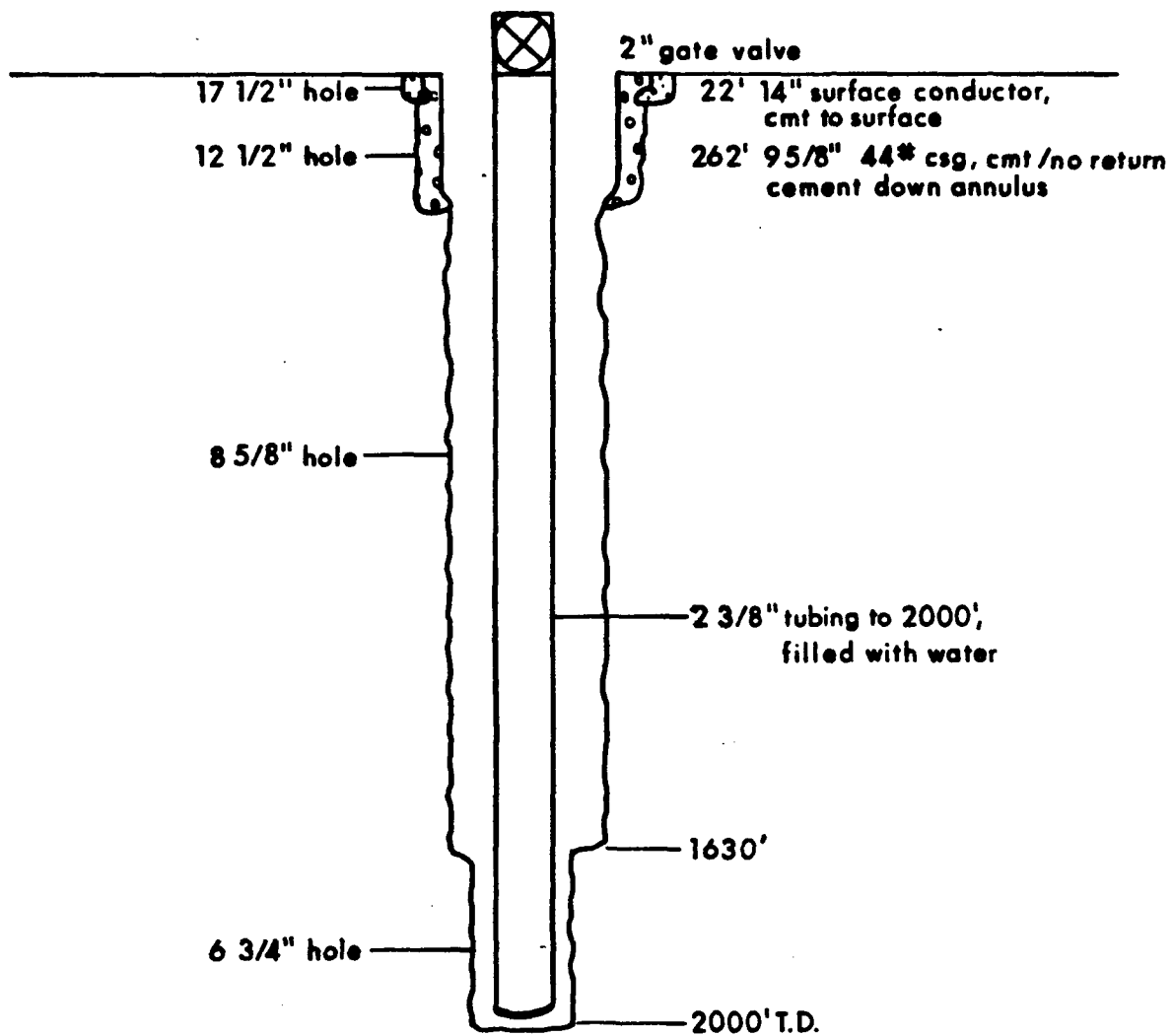

Figure 21- WELL COMPLETION SCHEMATIC DIAGRAM FOR 25-9

7 May 1981 Run 9 5/8" csg. to 300', cement/return to surface.  
8 May 1981 Install BOP test.  
9 May 1981 USGS BOP test okay but have to install steel blow line, drlg. 550'.  
10 May 1981 POH , bit change, drlg. to 820', making 100 gpm water.  
11 May 1981 Drlg. to 1060', making water.  
12 May 1981 Drlg. to 1300', making 115 gpm water.  
13 May 1981 Drlg. to 1330', flood hammer, POH, run 7" csg.  
14 May 1981 Run 7" csg. to 700' - wait on more csg.  
15 May 1981 Standby, waiting on csg.  
16 May 1981 Set 7" csg. to 1330', drld. to 1370', flooded hammer, POH, change bit, TIH, drlg. 1400'.  
17 May 1981 Switch to mud - drlg. new pits, mix muds.  
18 May 1981 Drlg. to 1568', POH, change bit.  
19 May 1981 POH, change bit, TIH, drlg. to 1800'.  
20 May 1981 Drlg. to 1830' - pull BOP, weld ring on 7" csg., rig up BOP.  
21 May 1981 Drlg. to 2035', run logs, rig down BOP.  
22 May 1981 Run 2 3/8" tubing to 2038' - pull 50' 7" csg.  
23 May 1981 Pulling 7" csg.  
24 May 1981 Pull 7" csg., rig down.

Table XI. Logging History for Well 38-9, McCoy Prospect, Nevada.

<u>Date</u>	<u>Type of Log</u>	<u>Logged Interval</u>	<u>Total Depth</u>
22 May 1981	Gamma Ray	0 -2025'	2038'
22 May 1981	SP	1350-2025'	2038'
22 May 1981	Resistivity	1330-2025'	2038'
31 July 1981	Temperature	20-2034'	2038'

Well 28-18 was spudded on May 27, 1981, drilled to 403 feet, casing set and cemented on June 1, 1981. The well was placed in suspension to be completed in 1982. The site was reoccupied June 17, 1982 and well 28-18 was completed to a depth of 1,948 feet on July 6, 1982. Well 28-18 was planned as a 3,000-3,500 foot thermal gradient observation well to test a geophysical anomaly. Lost circulation problems from 1,200 feet to

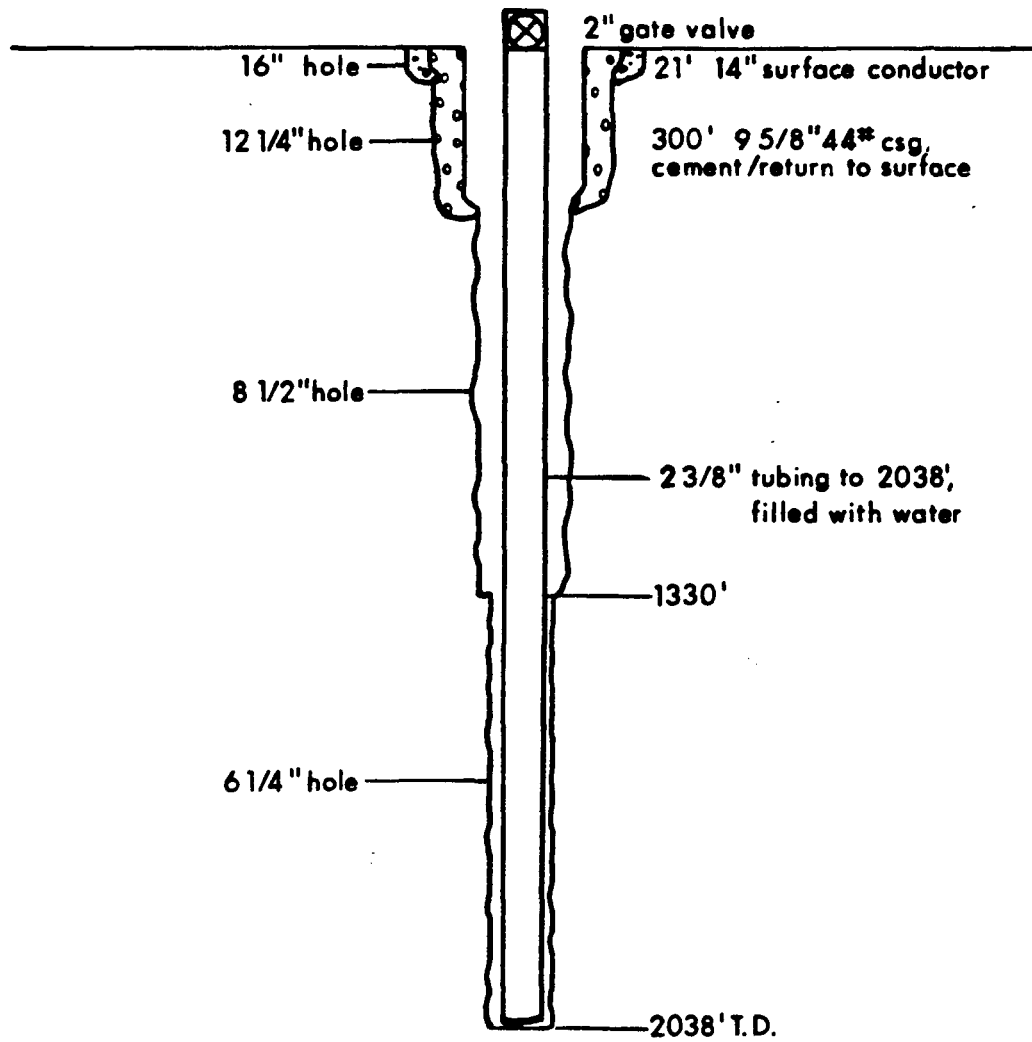

Figure 22-WELL COMPLETION SCHEMATIC DIAGRAM FOR 38-9

1,948 feet forced the well to be completed at a depth of 1,948 feet. The drilling history for well 28-18 is given in Table XII. The hole was drilled on air to a depth of 1,153 feet where it could not unload the well with air. Therefore, switched to mud and drilled ahead with severe lost circulation problems to 1,408 feet. Reamed hole to 1,303 feet losing approximately 10,000 gallon/day. Hung 7" casing to 1,303 feet and then drilled ahead with air and foam. continued lost circulation problems to 1,620 feet where lost all returns. Drilled blind to TD of 1,948 feet. Well 28-18 was completed as a temperature gradient hole (Fig. 23).

Table XII. Drilling History Well 28-18, McCoy Prospect, Nevada.

27 May 1981	Rig up, drld. 21', set 21' 14" surface conductor, cmt. Drld. to 45'.
28 May 1981	Drig. 12 1/4" hole to 200'.
29 May 1981	Drig. to 280', rig repair.
30 May 1981	Drig. to 403', run 9 5/8" csg. to 100'.
31 May 1981	Run 9 5/8" csg. to 403' - start to rig down.
1 June 1981	Cmt/returns to 15' from surface - fill annulus/cmt. from top. Rig down suspend well.
16 June 1982	George Mull Construction constructed a 300,000 gallon water storage reservoir five miles south-southwest of hole 28-18. Mull also began leveling the 28-18 site.
17 June 1982	Mull completed site preparation. Southwest Drilling moved equipment onto location and began rigging up. Magcobar delivered trailer with mud and other drilling supplies. H&H Oil Tool Co. delivered BOP equipment.
18 June 1982	Crew completed rigging up.
19 June 1982	Crew began working two shifts. Drilled out cement and casing shoe. Cement from 218-408 feet.
20 June 1982	Drilling with 6 1/2" hammer and 100' of 4 7/8" collars. Drilled 408-1,083 feet with penetration rates of 40-10 ft/hr. Penetration decreasing with depth. First water encountered at 600 feet, flowing 40 gpm at 960 feet, and 60 gpm at 1,083 feet. Collected 33°C water sample at 960 feet.

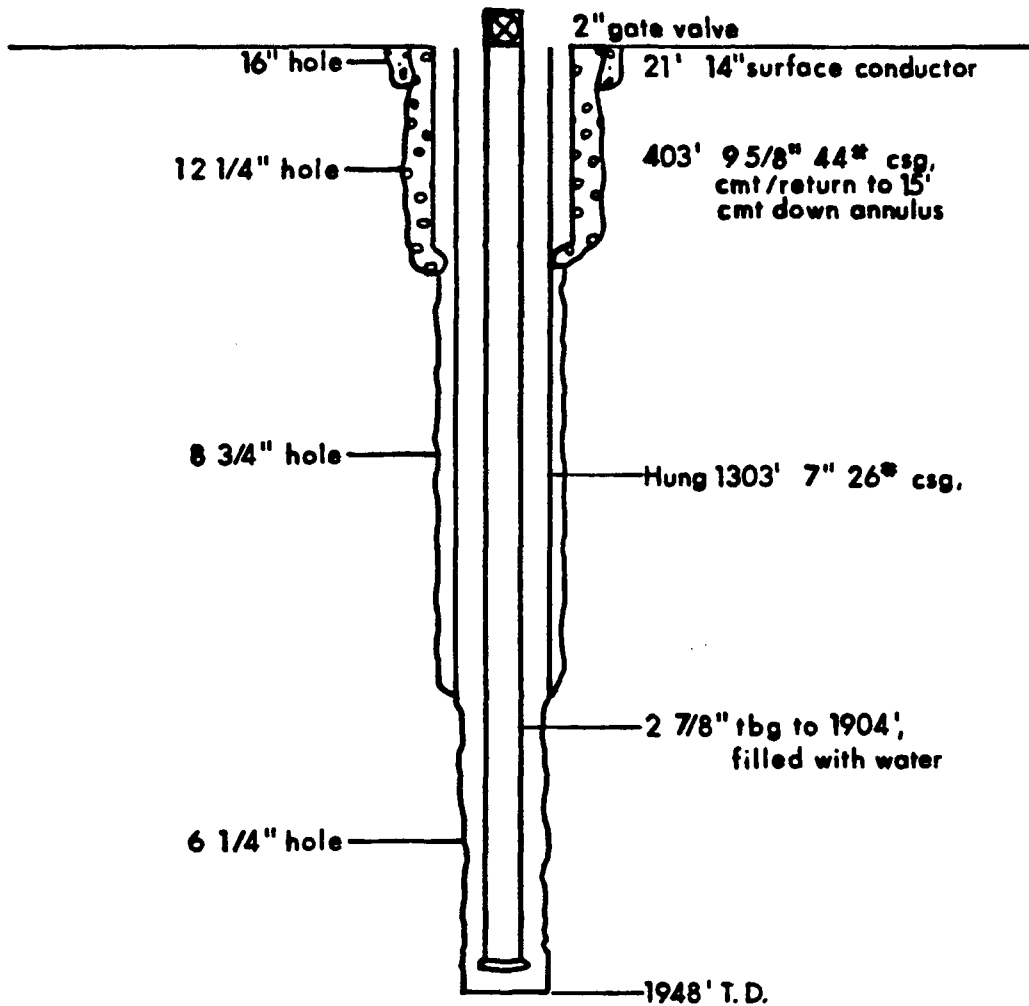

Figure 23 - WELL COMPLETION SCHEMATIC DIAGRAM FOR 28-18

- 21 June 1982      Unable to unload water from hole with air/foam, POH at 1,153. Brake failed while pulling out of hole, elevator and block dropped 40 feet into rotary table, five hours repairing equipment. Change to 6 1/4 button bit, RIH.
- 22 June 1982      Stuck pipe at 1,140 while RIH, crew spent six hours working pipe free, POH. Remainder of day hauling water and mixing mud.
- 23 June 1982      Mixing mud, condition hole, drill 1,153-1,158 feet.
- 24 June 1982      Drilling with mud, drilled 1,158-1,188 feet with 5 feet/hour penetration, POH, put on button finger bit, RIH, drill 1,188-1,333 feet with penetration of 15-20 feet/hour.
- 25 June 1982      Drilling 15 feet/hour from 1,333-1,408 feet. At 1,408 encountered hard fractured shales and chert and loss circulation, stuck rods, worked free, POH, mix mud. RIH and unload hole in stages with air/foam, unable to control water and caving, change back to mud. Considerable LC and caving.
- 26 June 1982      Haul water, mix mud, attempt to condition hole and regain circulation. Numerous bridges below 1,160 feet and difficult to keep hole open from 1,250-1,408 feet. Severe loss circulation at 1,408 feet.
- 27 June 1982      Crew on standby most of day, rig up to ream hole to 8 3/4" in preparation to running 7" casing.
- 28 June 1982      Reaming hole to 8 3/4" from 323-963 feet, plugged bit twice, some caving problems. Losing approximately 10,000 gallons of drilling fluid/day.
- 29 June 1982      Reaming hole to 8 3/4" from 963-1,263 feet, large wash out from 1,128-1,143 feet. Losing approximately 10,000 gallons of drilling fluids/day. H&H Oil Tool Co. delivered 7" elevators.
- 30 June 1982      Reaming hole to 8 3/4" from 1,263-1,303 feet, lost all fluids at 1,303 feet, stuck pipe for four hours, POH. Run 7" casing to 1,165 feet.
- 1 July 1982        RIH and clean hole below 7" casing to 1,290 feet, POH, set casing to 1,303 feet. 2 7/8" tubing arrived on location.



- 2 July 1982            Drilling 1,408-1,448 feet with 6 1/4" button bit and air/foam. Crew having problems with severe vibrations in booster compressor.
- 3 July 1982            Drilling 1,448-1,768 feet with 6 1/4" button bit and air/foam. Lost all returns at 1,620 feet, drill ahead blind. POH at end of shift.
- 4 July 1982            Change bits, RIH, reamed hole from 1,460-1,768 feet and drilled blind from 1,768-1,948. Hole began sluffing in at 1,948 feet, stuck drill pipe, mixed mud, broke pipe free, POH.
- 5 July 1982            RIH, hit bridge at 1,315 feet. Down for repair to booster compressor 0100-0800. Attempt to wash down with mud, unable to clean 1,320-1,328 feet section after six hours of conditioning. POH.
- 6 July 1982            Run 1,904 feet of 2 7/8" tubing, remove BOPE, unable to pull 7" casing. Sand pack hole with 4 yards of sand slurry, release rig at 1430.

The drilling problems encountered in drilling the intermediate depth thermal gradient wells are identical to those for the intermediate depth exploration wells, i.e. rig capacity, broken ground and lost circulation problems.

#### RESERVOIR ASSESSMENT

Geothermal exploration at the McCoy prospect has established the presence of two chemically distinct geothermal systems (Type II and II of Fig. 5). The purpose of this section of the report is to synthesize what the geological, geochemical and geophysical manifestations tell us about the reservoir.

#### Geological Manifestations

The McCoy prospect is characterized by the presence of a fossil spring deposit in the form of an extensive travertine deposit (Fig. 2). The mercury mineralization and associated hydrothermal alteration at the

McCoy Mine and Wildhorse Mine indicate a hydrothermal system had been present in the area, and may indicate the presence of an active geothermal system. The geologic manifestations suggest the presence of a geothermal system in the McCoy area in the past, but do not tell us much about a geothermal reservoir.

### Geophysical Manifestations

The presence of heat must be regarded as the most significant manifestation of a possible geothermal reservoir. The anomalous bottom hole temperatures, and hence anomalous geothermal gradients, measured in existing holes was one of the features which attracted AMAX to the McCoy area. The thermal anomaly (Fig. 8) as developed by the shallow exploration drilling program is large and contains three distinct highs, which were interpreted on possible hydrothermal convection cells. As such, they were targeted for intermediate depth exploration wells.

When an explorationist examines the thermal anomaly (Fig. 8) for McCoy two questions should come up: (1) can this data be obtained more economically, and (2) can the data be projected downward to give the location and depth to a heat source and/or geothermal reservoir. Lange (1978) established that from detailed temperature measurements made in the upper 10 meters of the thermal gradient wells on a common day provided data with which to compare temperatures near surface with those deeper in the hole (Fig. 24). Figure 25A shows the thermal anomaly at 3 meters while Figure 25B shows the thermal anomaly at 30 meters (Lange et al, 1982). Thus, we could have located the McCoy thermal feature with a 3 meter survey at a cost of 1/10th to 1/40th of that required for a 40 meter depth program.

The simplest method of projecting the thermal gradients to depth involves linear extrapolation (Fig. 26). This procedure is valid only in one-dimensional homogeneous half-space, i.e. it assumes no vertical or lateral changes in thermal conductivity and that the thermal regime is purely conductive. The end result is an approximation which can lead to misinterpretation. For example, the linear extrapolation of the thermal

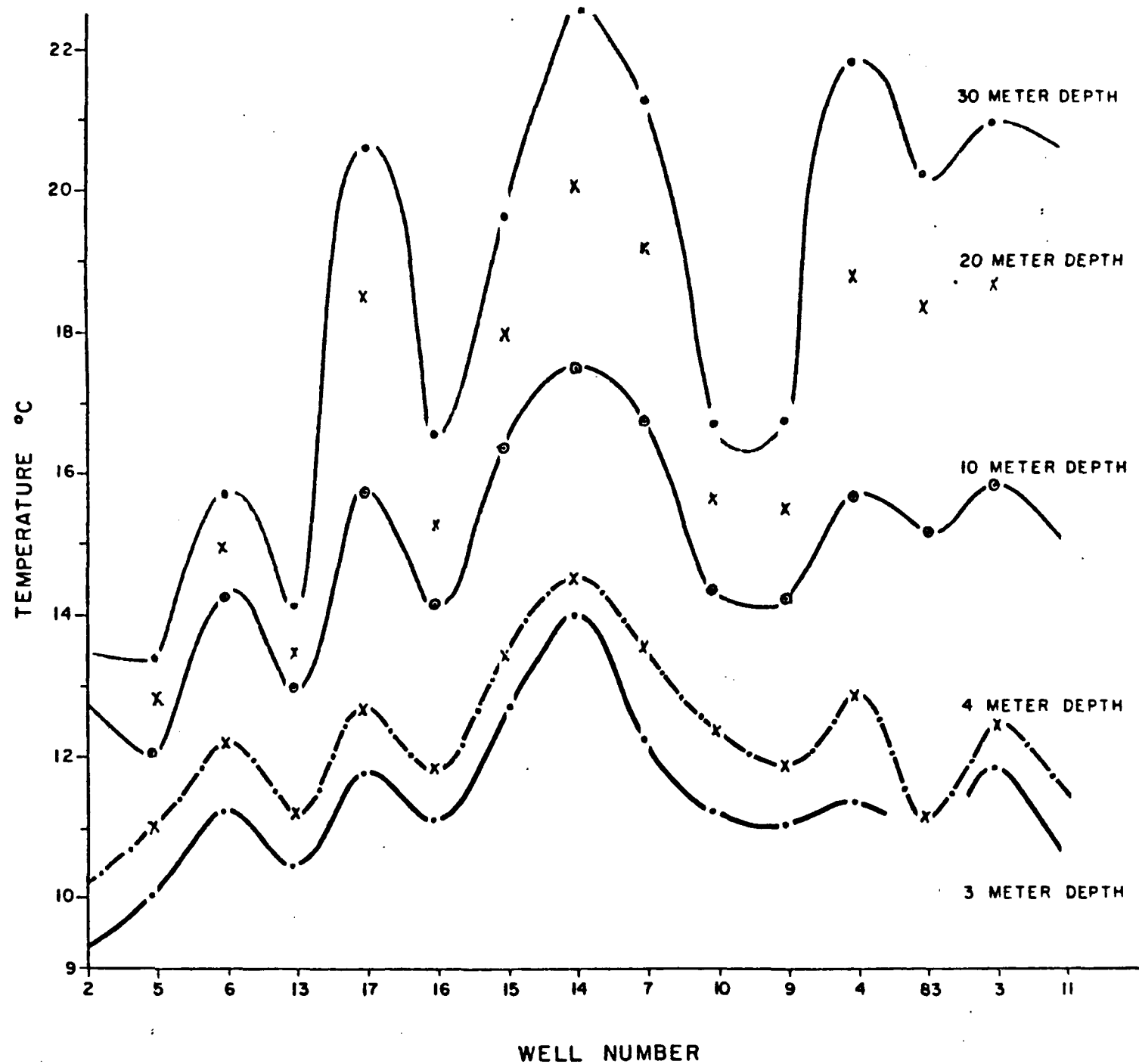

Figure 24. Temperatures at five different depths in each of the McCoy wells indicated. The deeper curves are essentially amplified versions of the shallow curves.

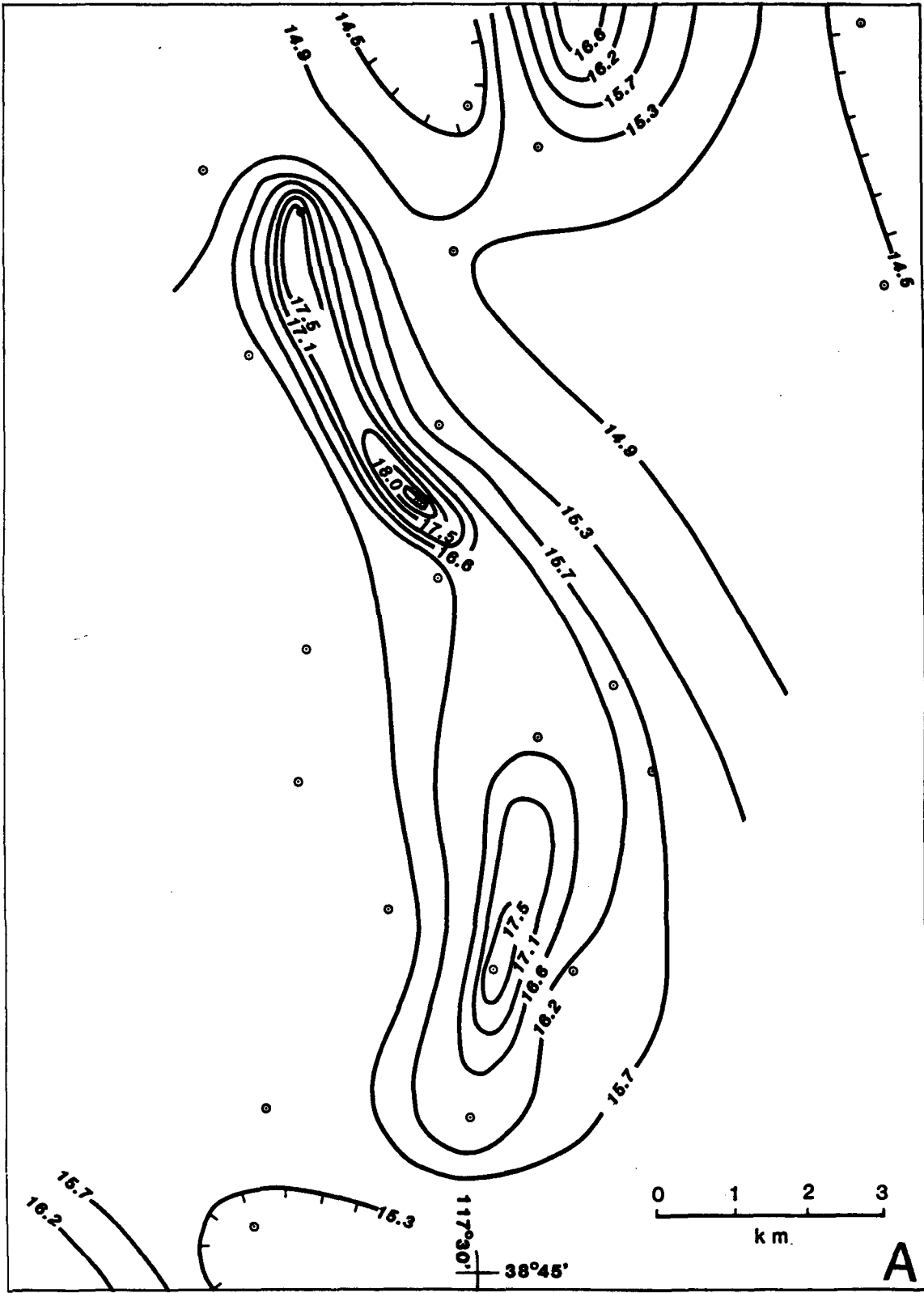

Figure 25. Plan view of the thermal anomaly at McCoy, Nevada. A) Temperatures at 3m. B) Temperatures at 30m (both adjusted for altitude), after Lange et al., 1982.

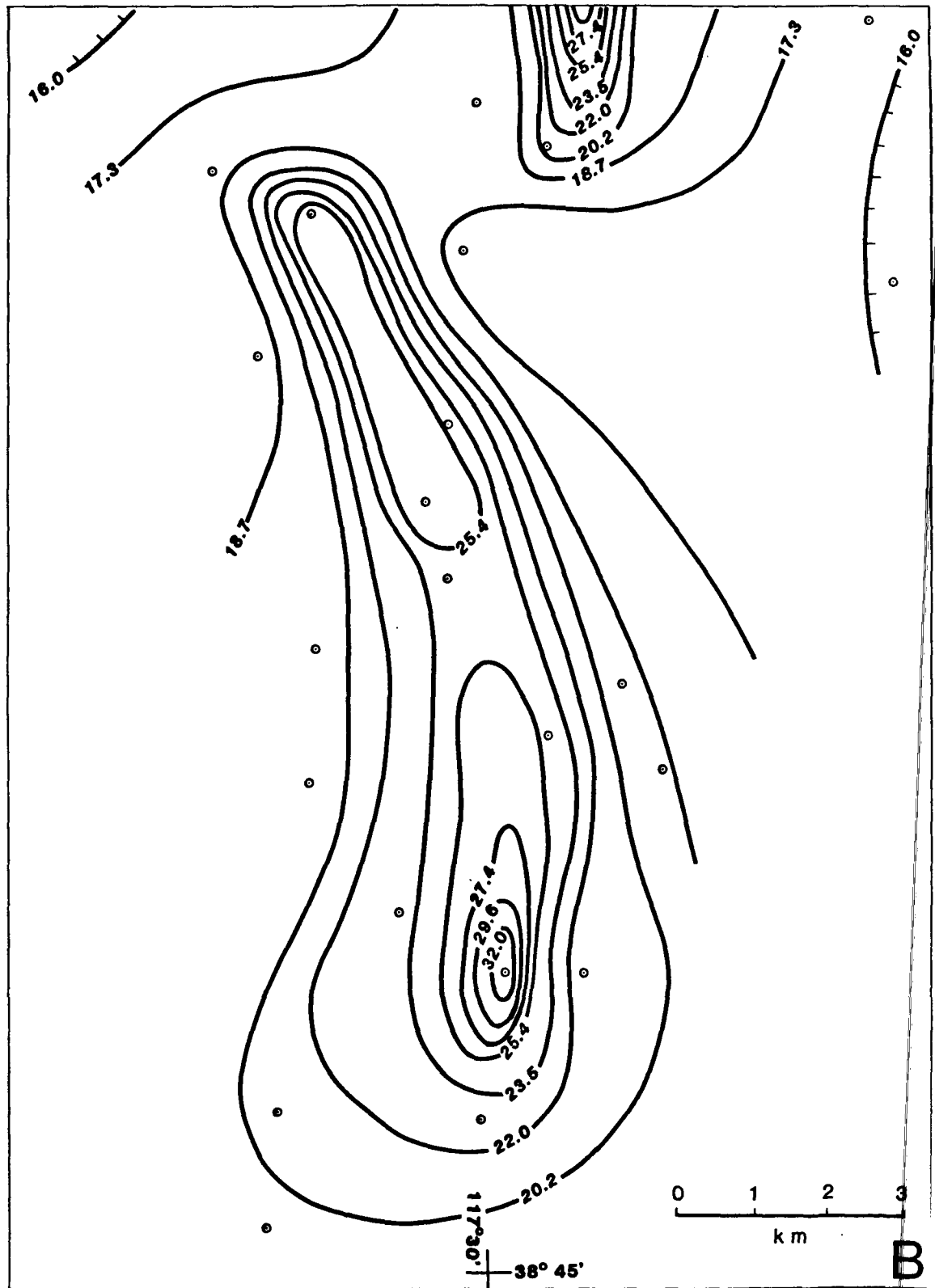
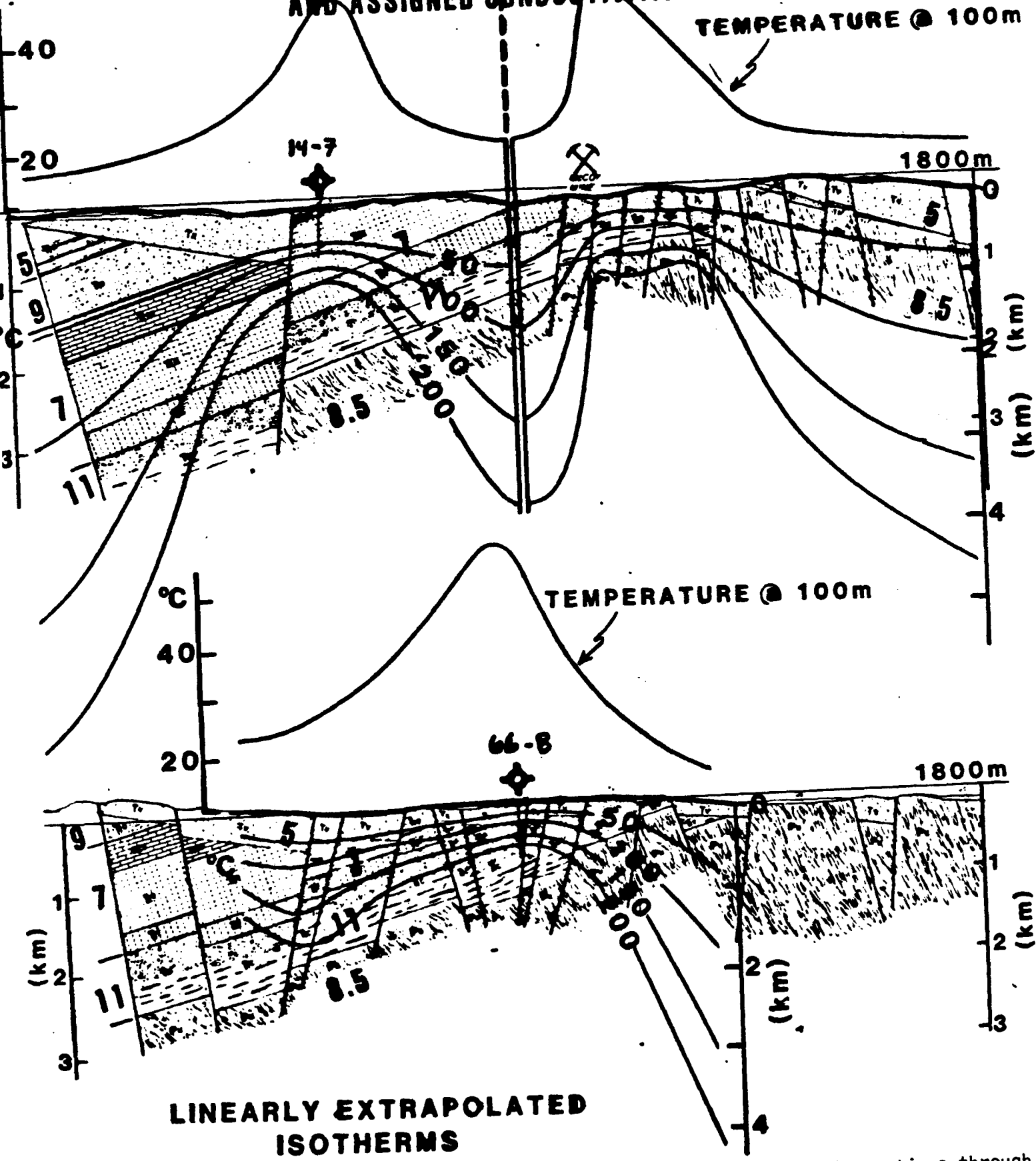

Figure 25. Plan view of the thermal anomaly at McCoy, Nevada. A) Temperatures at 3m. B) Temperatures at 30m (both adjusted for altitude), after Lange et al, 1982.

**GEOLOGIC CROSS-SECTIONS  
AND ASSIGNED CONDUCTIVITIES**



**LINEARLY EXTRAPOLATED  
ISOTHERMS**

Figure 26. Linearly extrapolated isotherms superimposed upon geologic sections through well 14-7 and well 66-8, McCoy prospect, Nevada (after Pilkington 1980 and Lange, 1981).

gradient based upon a shallow gradient hole near well 66-8 predicted temperatures in excess of 200°C at 2,000' depth (Fig. 26). However, the measured bottom hole temperature at 2476' was 85.7°C which is much less than predicted. Well 66-8 penetrated a 100°C aquifer at a depth of 1,630 feet which means we can not apply the linear extrapolation method of downward continuation of heatflow.

A three-dimensional heatflow downward-continuation program (Lange, 1981) has been applied to the McCoy data. The system is based upon patented theory and the thermal model is deduced from a three-dimensional thermal conductivity model. The results of downward continuation in a purely conductive model are shown in Figure 27. The model tends to spread the isotherms and tend to displace them downward; however, the predicted temperatures are still higher than the observed temperatures. The program will model the effects of intervening aquifers by the introduction of zones of very high thermal conductivities (Fig. 28). The simulation further depresses the isotherms so that the final result is much closer to the truth than was the pure conductive model. If one were to attempt to model all three aquifers encountered in well 66-8 perhaps the result would be even closer to the observed temperatures. However, the downward continuation program will not allow us to unequivocally define a geothermal reservoir.

The electrical geophysical methods have been touted, by many, as techniques which permit reservoir identification. The electrical resistivity of thermal waters are significantly different than those for the host rocks with the exception of clays. The measured resistivity depends upon the physical properties of the host rock, the porosity rock body, and the extent to which the voids are filled with thermal waters. Examination of the resistivity values determined over the southern thermal anomaly (Fig. 8) by the magnetotelluric method (Fig. 13) and by the dipole-dipole resistivity survey (Fig. 17) suggest that a depth of 0.5 km in well 66-8 (NWSE Sec 8 T22N R40E) the resistivities should be 20 ohm-meter range and at a depth of 1.0 km the resistivities should be on the order of 8 ohm-meters. Similarly the values in well 28-18 (SWSW Sec 18 T22N R40E) would be about 8 ohm-meters at a depth of 0.5 km and drop to 4 ohm-meters at a depth of 1.0 km. Figure 12 suggests the





DOWNWARD CONTINUATION: WITH EXTENDED AQUIFERS

GEOLOGIC CROSS-SECTIONS  
AND ASSIGNED CONDUCTIVITIES

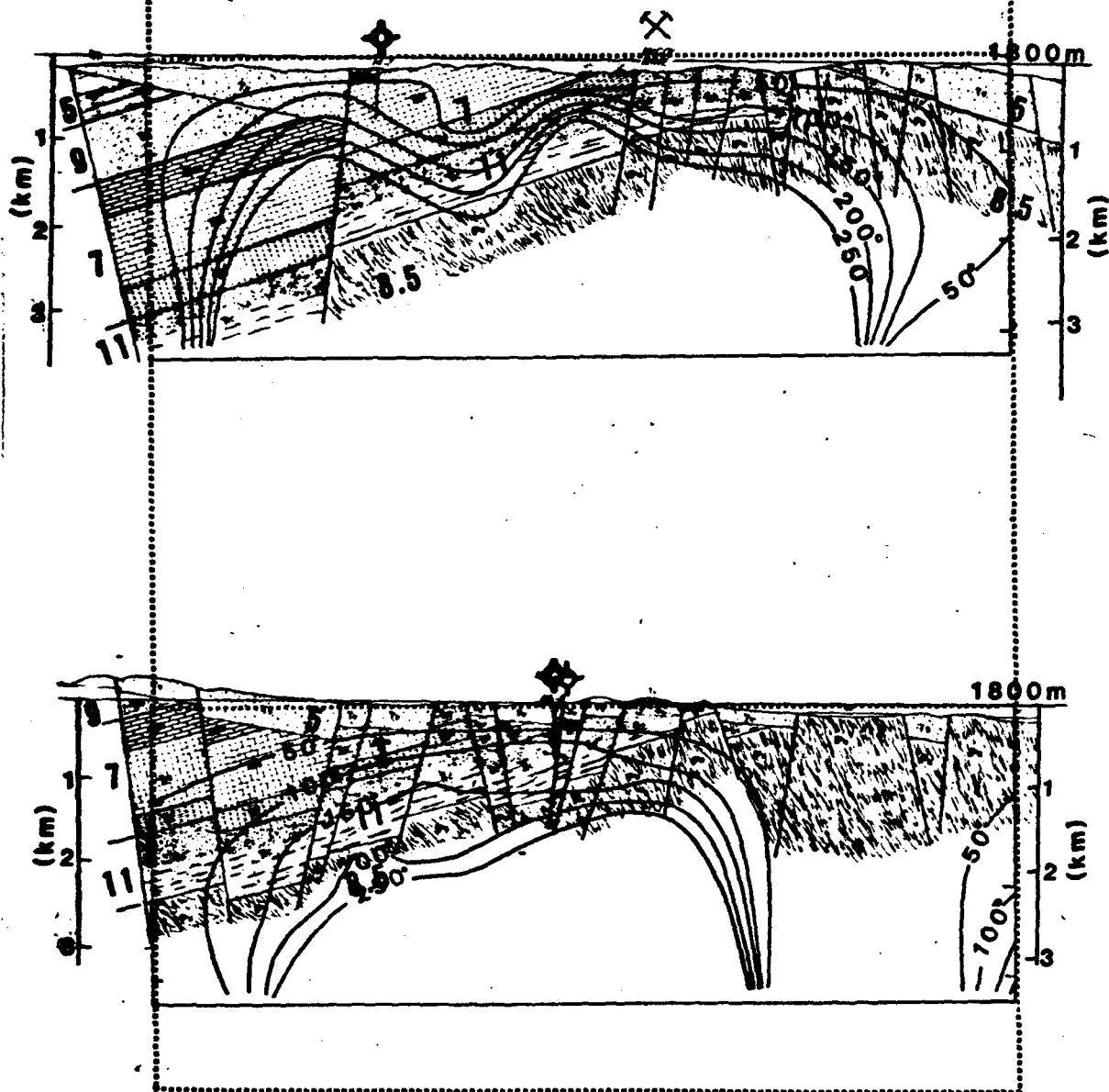

Figure 28. Three-dimensional downward continuation with extended aquifers (Tra limestone at well 14-7 and Trc conglomerate at well 66-8) superimposed on geologic sections, after Lange, 1981.

conductivities continue to increase to about 1 ohm-meter at a depth of 5 km. When we compare the geologic section through well 66-8 (Fig. 3) with the MT section (Fig. 13) we note major discrepancies between the measured resistivities and those one would assign based upon rock type; i.e. the measured values are one to two orders of magnitude lower than the rock resistivities expected. The electric well log for 66-8 gives a value of 60 ohm-meters for the Triassic conglomerates at a depth of 0.5 km. The temperature log for well 66-8 was basically isothermal below a depth of 0.5 km which suggests a low temperature geothermal reservoir is present below 0.5 km. The electrical conductivity of the waters encountered in wells 66-8, 25-9 and 28-18 suggests that the resistivity values determined from the MT are dominated by the geothermal fluids and thus, the electrical methods did in fact see the low geothermal reservoir.

#### Geochemical Manifestations

Geochemically the thermal waters encountered in the exploration drilling at the McCoy prospect are into two distinct types (Fig. 5). However, all the thermal waters are Na-HCO<sub>3</sub>-SO<sub>4</sub>-Cl waters. The McCoy Mine area waters have a higher sodium content than the thermal waters from the southern part of the area (wells 66-8, 25-9 and 2818). Table XIII is a summary of the chemical geothermometers for the McCoy thermal waters.

Table XIII. Chemical Geothermometry Summary - McCoy Thermal Waters.

<u>Well &amp; Sample Depth</u>	<u>T<sup>0</sup>CSiO<sub>2</sub></u>	<u>T<sup>0</sup>C Na-K-Ca</u>	<u>T<sup>0</sup>CNa-K-Ca-Mg</u>	<u>T<sub>11</sub></u>	<u>Max T<sup>0</sup>C obs.</u>
66-8 - 1630'	*148	205	128	142	102
2050'	120	197	R > 50	124	102
2050'	115	194	R > 50	124	102
2410'	112	197	R > 50	131	102
28-18 - 1470'	123	207	122	86	62
38-9 - 550'	66-Chal.	171	45	116	45
1200'	55 "	163	63	116	45
1300'	55 "	162	60	116	45
25-9 - 1640'	25-Chal.	69	R > 50	116	71
1840'	40 "	53	51	104	71
2000'	55 "	50	R > 50	86	71

\*High SiO<sub>2</sub> may be related to contamination by drill cuttings.

The silica geothermometers for well 66-8 all indicate subsurface temperatures of 120°C or less except for  $T_{qSiO_2}$  of 148°C from the first water sample collected. If we throw out the first silica value and the first Li value then the remaining geothermometers agree quite well. The chemical geothermometers applied to average of the other three analyses are:  $TSiO_2$  115°C,  $TNa-K-Ca$  196°C,  $TNa-K-Ca-Mg$  128°C and  $T_{Li}$ , 127°C. The Mg correction brings the alkali geothermometer into good agreement with silica for both well 66-8 and well 28-18. The general agreement between the silica geothermometer and the alkali or Mg corrected alkali geothermometers in well 38-9 and 25-9 lend credibility to the values. Thus, for 38-9 the maximum subsurface temperature seen by those waters is 60-62°C and for well 25-9 it is about 50°C which was equal to temp of water produced.

The waters of well 38-9 and well 25-9 are products of deep circulation along faults and then lateral migration. In well 25-9 it would appear we are seeing recharge waters.

The waters from well 28-18 and 66-8 are probably a part of the same hydrological regime and represent waters which migrated downward along faults and fractures to a depth where the rock temperatures were in the 100-128°C range. The waters were heated then moved upward until they reached the appropriate reservoir in the Triassic rocks then moved laterally. Some dilution with cool meteoric waters could have occurred.

## BIBLIOGRAPHY

- Adams, Mike, Moore, J. N. , Struhsacker, Eric, 1980, Preliminary geologic map McCoy area, Nevada: Unpublished UURI map.
- Dellechiaie, F., 1977, Hydrogeochemistry McCoy geothermal prospect: AMAX Exploration, Inc., I.O.M.
- Lange, A. L., 1978, Temperature surveys in 2-meter holes can be effective; AMAX Exploration, Inc., IOM.
- Lange, A. L., 1980, The McCoy, Nevada geothermal prospect: Paper presented at Soc. Exploration Geophysicist Ann. Mtg.
- Lange, A. L., 1981, Downward continuation of temperature data at McCoy, Nevada; AMAX Report.
- Lange, A. L., Pilkington, H. D., and Deymonaz, John, 1982, Comparative studies of geothermal surveys in 3-meter and temperature gradient holes; Geothermal Resources Council Transactions Vol. 6, 1982.
- McKee, E. H. and Steward, J. H., 1971, Stratigraphy and K-AR ages of some Tertiary tuffs from Lander and Churchill Counties, Nevada: U. S. Geological Survey Bull 1311-B.
- Olson, H. J., Dellechiaie, F., Pilkington, H. D. and Lange, A. L., 1979, the McCoy geothermal prospect a status report of a possible new discovery in Churchill and Lander Counties, Nevada: Geothermal Resources Council Transactions Vol. 3.
- Pilkington, H. D., 1980, Geochemical study drill cuttings, McCoy: AMAX Exploration, Inc., I.O.M.
- Pilkington, H. D., 1982, McCoy area, Nevada, Geothermal reservoir assessment case history, Northern Basin and Range, annual report 1 January 1981-31 December 1981, DOE Contract DE AC08-79ET 27010.
- Shenker, A. E., 1980, Summary hydrogeochemistry from McCoy Well 66-8: AMAX Exploration, Inc., I.O.M.
- Stewart, J. H. and McKee, E. H., 1977, Geology and mineral deposits of Lander County, Nevada: Nevada Bur. Mines and Geology, Bull. 88.
- Terraphysics, 1980, Telluric-Magnetotelluric survey at McCoy prospect, Churchill County, Nevada: AMAX Exploration, Inc., Report
- Wilden, R. and Speed, R. C., 1974, Geology and Mineral deposits of Churchill County, Nevada: Nevada Bur. Mines and Geology, Bull. 83.
- Wilt, M., Haught, R. and Goldstein, N. E., 1980, An electromagnetic (EM-60) survey of the McCoy geothermal prospect, Nevada: Lawrence Berkley Laboratory, Univ. of California, Berkley Rept. 66a.

**GEOTHERMAL BRANCH**

February 23, 1983

Mr. Dennis Nielson  
University of Utah Research Institute  
Earth Science Laboratory  
420 Chipeta Way Suite 120  
Salt Lake City, Utah 84108

Re: McCoy DE-AC08-ET27010 Final Report

Dear Dennis:

Joe Fiore requested replacement diagrams for Figure 25 of the above referenced report. The A and B portions of the original Figure 25 have been placed onto separate pages. The "A" portion has been designed to face the "B" portion of the figure. Please find enclosed three (3) copies of Figure 25 A and B.

Sincerely,  
AMAX Exploration, Inc.



H. D. Pilkington  
Chief Geologist, Geothermal Branch

HDP:cm  
Enclosure: 6

cc: Joe Fiore

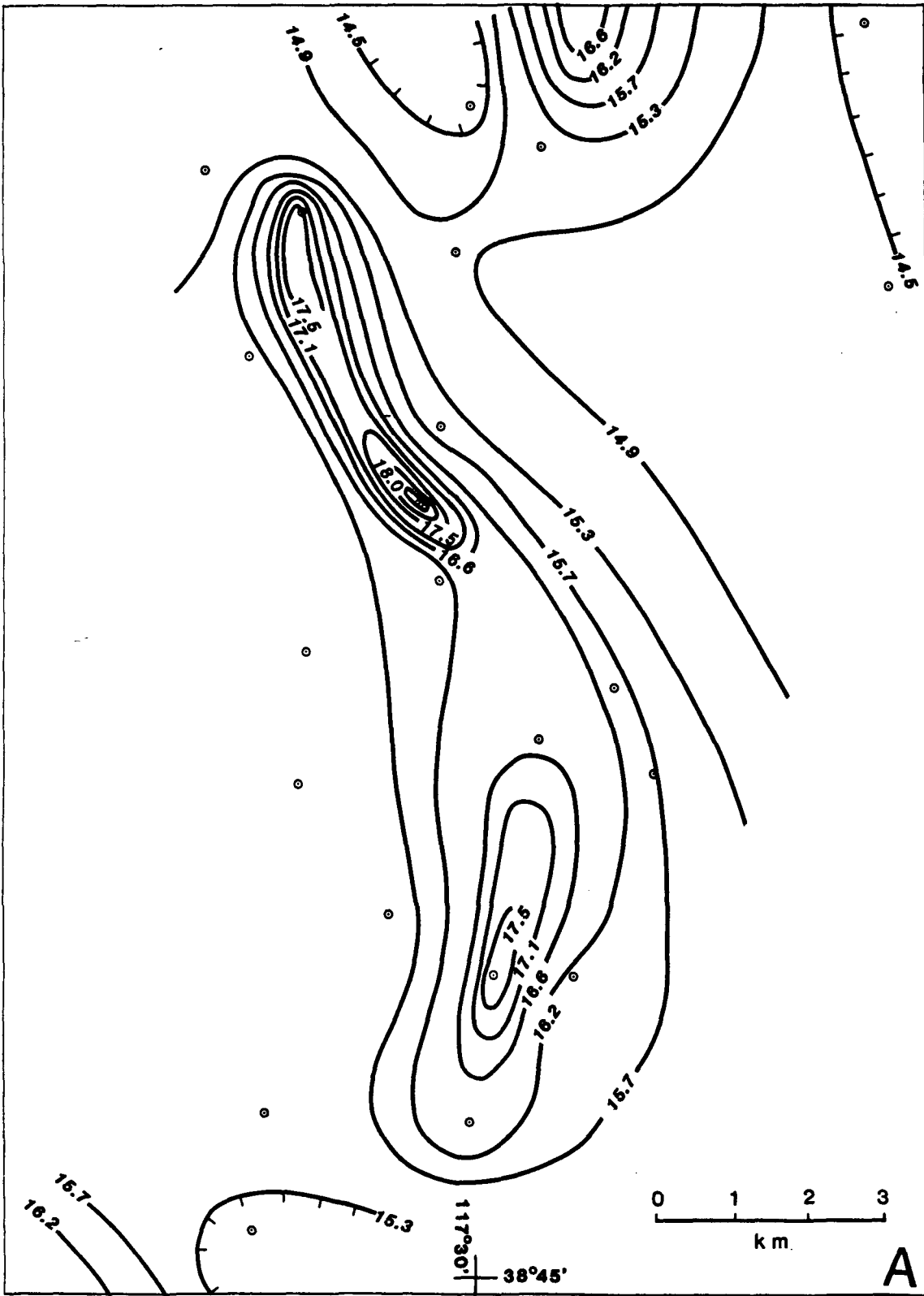

Figure 25. Plan view of the thermal anomaly at McCoy, Nevada. A) Temperatures at 3m. B) Temperatures at 30m (both adjusted for altitude), after Lange et al., 1982.

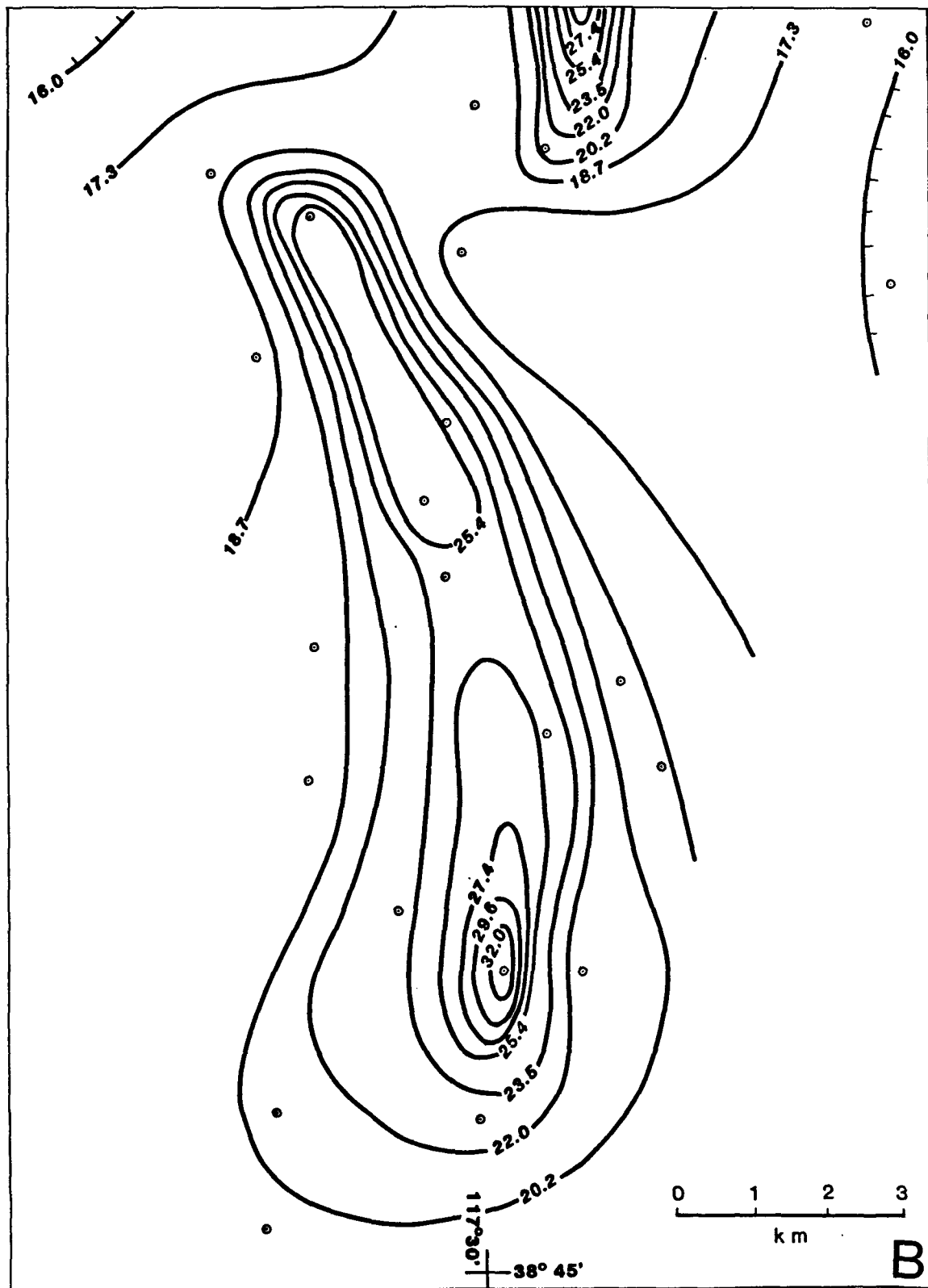

Figure 25. Plan view of the thermal anomaly at McCoy, Nevada. A) Temperatures at 3m. B) Temperatures at 30m (both adjusted for altitude), after Lange et al., 1982.