

GLD1648

358p.

SKB-TR-85-11

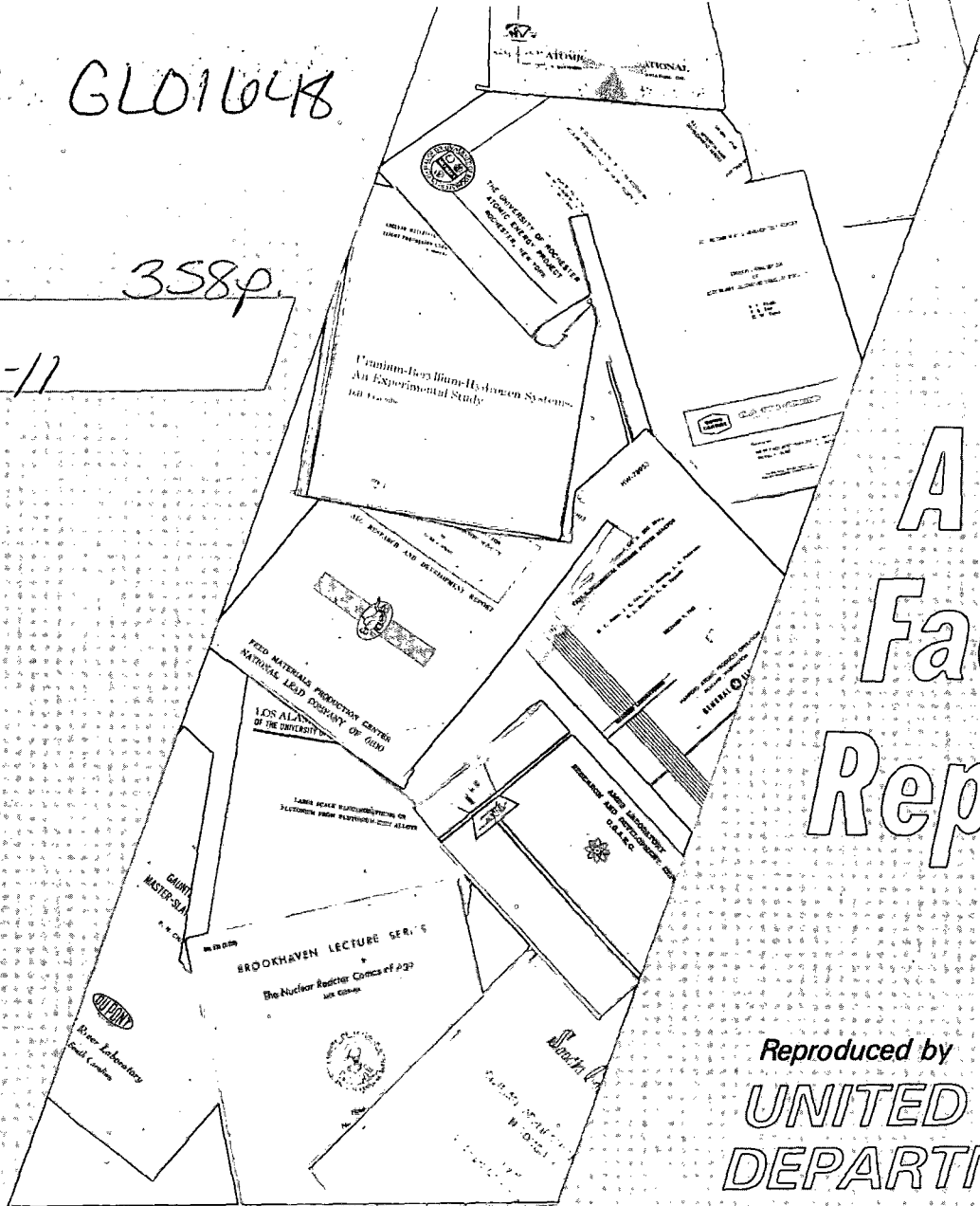

A Facsimile Report

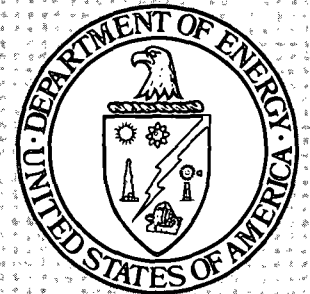

Reproduced by
**UNITED STATES
DEPARTMENT OF ENERGY**
Office of Scientific and Technical Information
Post Office Box 62 Oak Ridge, Tennessee 37831

SE 860 000 7

GLO1648

SKB

**TECHNICAL
REPORT**

85-11

**Hydrochemical investigations in
crystalline bedrock in relation to
existing hydraulic conditions:
Experience from the SKB test-
sites in Sweden**

John Smellie, Nils-Åke Larsson
(Swedish Geological Company, Uppsala, Sweden)

Peter Wikberg
(Royal Institute of Technology, Stockholm
Sweden)

Leif Carlsson
(Swedish Geological Company, Göteborg,
Sweden)

November 1985

SVENSK KÄRNBRÄNSLEHANTERING AB
SWEDISH NUCLEAR FUEL AND WASTE MANAGEMENT CO

BOX 5864 S-102 48 STOCKHOLM
TEL 08-679540 TELEX 13108-SKB
TEL 08-652800

HYDROCHEMICAL INVESTIGATIONS IN CRYSTALLINE BEDROCK
IN RELATION TO EXISTING HYDRAULIC CONDITIONS:
EXPERIENCE FROM THE SKB TEST-SITES IN SWEDEN

John Smellie
Niils-Åke Larsson
(Swedish Geological Company, Uppsala, Sweden)
Peter Wikberg
(Royal Institute of Technology, Stockholm, Sweden)
Leif Carlsson
(Swedish Geological Company, Göteborg, Sweden)

November 1985

This report concerns a study which was conducted for SKB. The conclusions and viewpoints presented in the report are those of the autor(s) and do not necessarily coincide with those of the client.

A list of other reports published in this series during 1985 is attached at the end of this report. Information on KBS technical reports from 1977-1978 (TR 121), 1979 (TR 79-28), 1980 (TR 80-26), 1981 (TR 81-17), 1982 (TR 82-28), 1983 (TR 83-77) and 1984 (TR 85-01) is available through SKB.

SWEDISH GEOLOGICAL COMPANY
Division of Engineering Geology
Client: SKB

REPORT
ID-no: IRAP 85254
Date: 1985-11-20

HYDROCHEMICAL INVESTIGATIONS IN CRYSTALLINE BEDROCK
IN RELATION TO EXISTING HYDRAULIC CONDITIONS:
EXPERIENCE FROM THE SKB TEST-SITES IN SWEDEN

John Smellie¹
Nils-Åke Larsson¹
Peter Wikberg²
Leif Carlsson³

- ¹ Swedish Geological Company, Uppsala
- ² Royal Institute of Technology, Stockholm
- ³ Swedish Geological Company, Göteborg

HYDROCHEMICAL INVESTIGATIONS IN CRYSTALLINE BEDROCK IN RELATION
TO EXISTING HYDRAULIC CONDITIONS: EXPERIENCE FROM THE SKB
TEST-SITES IN SWEDEN

	Page
1. INTRODUCTION	1
2. PARAMETERS CONSIDERED	3
2.1 Hydrologic Parameters	4
2.2 Chemical Parameters	10
2.2.1 General water chemistry	12
pH and carbonate content	13
Sodium, calcium and chloride content	14
Redox sensitive parameters	14
2.2.2 Uranium investigations	16
Uranium geochemistry	17
Uranium isotope geochemistry	20
2.2.3 Environmental Isotopic Studies	22
Tritium	23
Radiocarbon	24
Oxygen and deuterium	26
3. INFLUENCE ON GROUNDWATER CONDITIONS BY BOREHOLE AND BOREHOLE ACTIVITIES	29
3.1 General	29
3.2 Borehole Drilling	31
3.2.1 Performance	31
3.2.2 Influence on the groundwater	32
3.3 Gas-lift Pumping	37
3.4 Hydraulic Testing	38
3.4.1 General	38
3.4.2 Influence on the groundwater conditions	40
3.5 Water Sampling	43
3.6 Open-hole Effect	44
3.6.1 General considerations	44
3.6.2 Numerical calculations	47
3.7 Drilling Debris	52
3.8 Summary	57

4. GROUNDWATER SAMPLING AND ANALYSIS	61
4.1 Sampling Procedures	61
4.2 Sample Preparation and Analysis	65
5. RESULTS FROM THE TEST-SITE INVESTIGATIONS	67
5.1 Fjällveden	68
5.1.1 Borehole Fj 2	73
5.1.2 Borehole Fj 4	94
5.1.3 Borehole Fj 8	112
5.2 Gideå	123
5.2.1 Borehole Gi 2	129
5.2.2 Borehole Gi 4	149
5.3 Svartboberget	172
5.3.1 Borehole Sv 4	178
5.3.2 Borehole Sv 5	195
5.4 Kamlunge	214
5.4.1 Borehole Km 3	220
5.4.2 Borehole Km 13	231
5.4.3 Borehole Km 8	249
5.5 Taavinunnanen	256
5.5.1 Borehole Ta 1	260
5.6 Klipperås	269
5.6.1 Borehole Kl 1	273
6. DISCUSSION AND CONCLUSIONS	279
6.1 General Geological and Hydrogeological Features of the Representative Groundwater Horizons	279
6.2 General Hydrochemical Characteristics of the Groundwaters	282
6.3 Groundwater Redox Conditions and the Geochemical Behaviour of Uranium	284
6.4 Hydrological Models	288
6.5 Gas-lift Pumping	290
6.6 Location of Hydraulically-conducting Horizons	293
6.7 Influence of Bedrock Geochemistry on the Groundwater Chemistry	294
6.8 The Relationship Between Fracture Mineralogy and Groundwater Characteristics	296

6.9 Influence of Pumping on the Physico-chemical Properties of Groundwaters	298
6.10 Drilling Water Properties	299
6.11 Bedrock Sampling Locations - Bedrock vs Fracture Zones	300
6.12 Borehole Sealing	302
7. RECOMMENDATIONS FOR IMPROVING GROUNDWATER SAMPLING QUALITY	304
7.1 Cored Borehole System	304
7.2 Percussion (Booster) Hole Drilling	306
8. ACKNOWLEDGEMENTS	309
9. REFERENCES	310
10. APPENDICES	324
Appendix 1: Theoretical models on the open-hole effect	324
Appendix 2: Numerical calculations of the open-hole effect	332
Appendix 3: Groundwater pump flow-rate and its effect on some physico-chemical parameters - controlled experiments carried out at Kamlunge and Taavinunannen	342

ABSTRACT

This report represents the compilation, discussion and interpretation of hydrochemical and hydraulic data resulting from the SKB test-site investigations carried out over a period of three years (1982-84). By systematically applying hydrological and geological considerations to each sampled horizon, it has been possible to differentiate between those groundwaters which are reasonably representative for the depth sampled, from those which have been subject to contamination from different sources. Groundwaters which are here considered representative are defined as those which show no evidence of mixing with other water sources, whether from drilling water, younger, near-surface water, or other deeper groundwaters. As a consequence, only a very few sampled horizons can be considered worth serious hydrochemical attention. The lack of representative groundwater samples, whilst often due to technical problems or sampling from non-conductive sections of the boreholes, also illustrate the extremely complex geometry of the permeable fracture systems in crystalline bedrock, and thus the difficulty of establishing the nature and depth relation of the groundwater reservoir tapped.

Although the main findings of this study have revealed gross inadequacies in the hydrochemical programme, valuable experience has nevertheless been gained. Consequently, some of the improvements recommended in Section 7 of this report have been already implemented resulting in higher sampling standards and thus water samples which are much more representative for the hydrogeological environment under investigation.

HYDROCHEMICAL INVESTIGATIONS IN CRYSTALLINE BEDROCK IN RELATION TO EXISTING HYDRAULIC CONDITIONS: EXPERIENCE FROM THE SKB TEST-SITES IN SWEDEN

1. INTRODUCTION

One of the many difficulties to be surmounted in the storage of high-level radioactive waste is predicting the long-term effects on the geological environment in the event of a slow release of radionuclide material (i.e. through canister corrosion) to circulating meteoric groundwaters within the surrounding bedrock repository. For the crystalline bedrock repository as envisaged in the SKB programme, the rocks at disposal depths will be fractured, even prior to excavation, and that fracture permeability will be the dominant mode of flow. A sound knowledge of fracture geometry, hydraulic flow and groundwater chemistry within the bedrock is therefore an essential prerequisite for radioactive disposal safety assessment.

Deep hole hydrogeological and hydrochemical investigations have been a feature of the SKB programme for site characterisation during the last 4 years. This has been a time for instrumental development, of proving different techniques, and adapting previously established methods used with success in other geological environments. One major problem is that most of the well documented hydrogeological and hydrochemical studies have been confined to sedimentary strata-bearing aquifers (i.e. a porous medium continuously saturated with water) where groundwater flow patterns and redox parameters can be relatively easily monitored and modelled. Contrastingly, in crystalline bedrock areas groundwater movement is largely controlled by fractures, cracks, and fissures in an otherwise impermeable medium. This situation presents a whole new host of problems to be solved, affecting all aspects of the site characterising programme.

SKB TEST SITES DESCRIBED IN THIS REPORT

- 1 FJÄLLVEDEN
- 2 GIDEA
- 3 SVARTBOBERGET
- 4 KAMLUNGE
- 5 TAAVINUNNANEN
- 6 KLIPPERAS

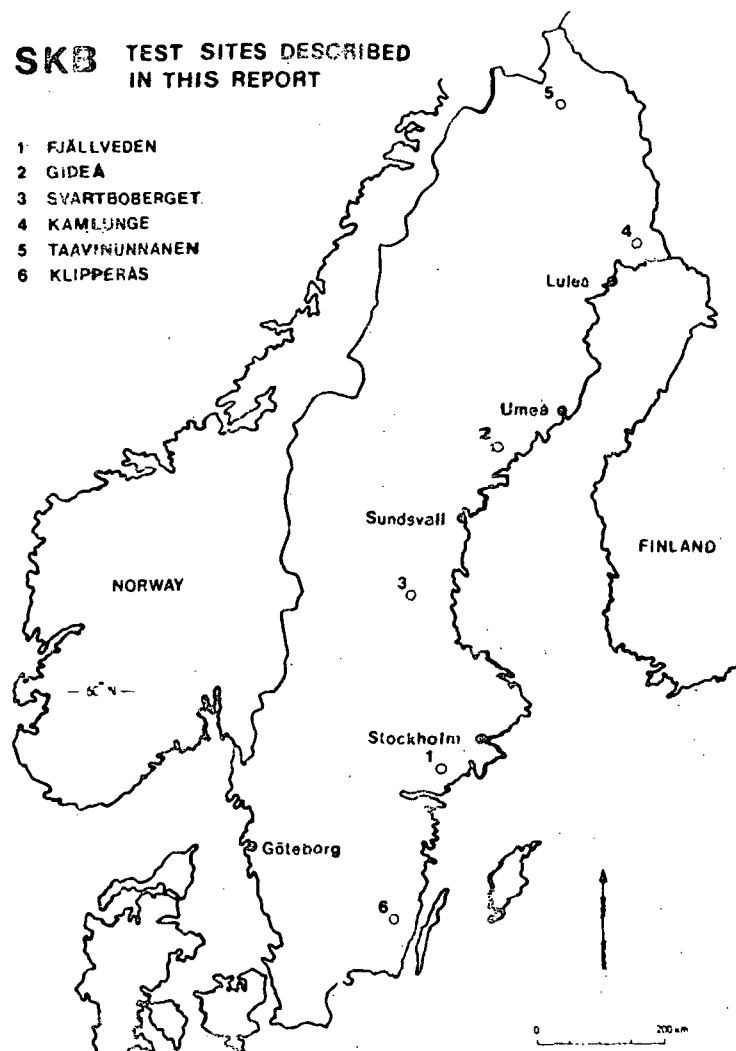

Fig. 1 Location of the SKB test-site areas described in this report.

This report presents the results of hydrogeological and hydrochemical investigations carried out at six sites in Sweden during the last 4 years (Fig. 1). Emphasis is put on deep hole hydrological characterisation of fractured bedrock environments and groundwater sampling methods, and their influence on the groundwater chemistry, particularly with reference to redox-sensitive parameters such as Eh, pH, pS, environmental isotopes such as ^2H , ^3H , ^{18}O , ^{13}C , ^{14}C and the chemical and radiochemical behaviour of uranium.

2. PARAMETERS CONSIDERED

Before describing the various hydrologic and chemical parameters measured and discussed below, it is considered expedient to resolve some of the difficulties in the use of hydrologic and hydrochemical terminology employed to describe the type and character of the waters. Figure 2.1 illustrates a schematic representation of the terminology used in this report.

For a static hydraulic system, the hydrologic use of surface water, near-surface water and groundwater, which relate to depth of origin, conform fairly well with the hydrochemical descriptive terms which relate to redox conditions and the general chemistry of the waters, both of which are usually to some degree a function of depth. However, for a dynamic hydraulic system the description of the water characteristics can be highly variable depending on whether recharge or discharge environments are being discussed. For example, in an area of recharge characterised by a steep hydraulic gradient extending to depth (e.g. via a large-scale fracture), waters which are oxidising and with a low pH can quickly penetrate through the bedrock resulting, in the extreme case, in an intermediate to deep groundwater of typical surface to nearsurface chemistry. Contrastingly, in a strongly discharging area, deep groundwaters of a highly reducing character can dominate the near-surface and even the surface water environments.

As most of the hydrogeological systems in this report relate to active flow conditions, the terminology outlined in Figure 2.1 has been employed to clarify the very complex nature of groundwater flow and chemistry, both within the undisturbed bedrock prior to drilling, and subsequently when changes are incurred during and after drilling.

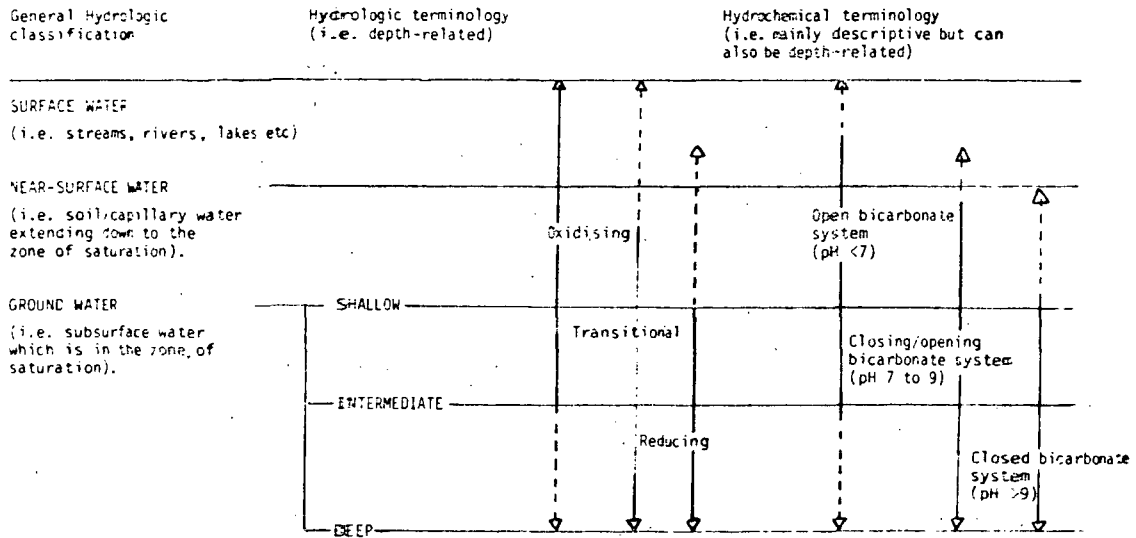

Figure 2.1: Schematic representation of groundwater characteristics within a non-static hydraulic flow system.

2.1 Hydrologic Parameters

The occurrence of mobile groundwater in crystalline rock environments is restricted to the interconnected system of fractures in the bedrock. Water-filled voids in the bedrock unconnected to the fracture system exist, but are not considered to take part in the flow of groundwater.

The flow of groundwater is in most cases laminar and the velocity is therefore determined by the hydraulic gradient and the conductivity of the medium in which the flow occurs. This statement, known as Darcy's Law, is valid for porous media and can be expressed as:

$$Q = v \cdot A = -K \cdot A \frac{dh}{dt} \quad (2.1)$$

- Q = flow (m^3/s)
 v = velocity (m/s)
 A = area (m^2)
 K = hydraulic conductivity (m/s)
 dh/dl = hydraulic gradient (m/m)

The hydraulic conductivity (K) depends on the properties of the rock medium and fluid (water) which are generally assumed to be constant. Thus, the hydraulic gradient represents the force that initiates groundwater flow. If the hydraulic gradient is equivalent to the energy loss (dh) along a flow path, dl , then h can be expressed as:

$$h = Z + \frac{p}{\gamma} \quad (2.2)$$

- Z = elevation above an arbitrary datum plane (m)
 p = groundwater pressure at the elevation Z (N/m^2)
 γ = specific weight of fluid ($kg/m^2 s^2$)

At the groundwater table, $p = 0$ and consequently $h = Z$. This means that the flow between two points near the groundwater table is proportional to the dip of the groundwater table. At greater depth the hydraulic gradient decreases as does the groundwater flow (Figure 2.2).

At any depth beneath the groundwater table a unit mass of fluid is subject to both gravitational and pressure forces. By defining a force potential $\phi^* = g h$, it follows that:

$$\text{grad } \phi^* = g \frac{dh}{dl} = g \left(\text{grad } Z + \frac{1}{\gamma} \text{grad } p \right); \quad (2.3)$$

g = acceleration due to gravity (m/s^2) and

$$Q = v A = -K A \frac{dh}{dl} = -K A \left(\text{grad } Z + \frac{1}{\gamma} \text{grad } p \right) \quad (2.4)$$

$$Q = -\frac{K}{g} A \text{ grad } \phi^* \quad (2.5)$$

$$\underline{v} = -\frac{K}{g} \text{ grad } \phi^* \quad (2.6)$$

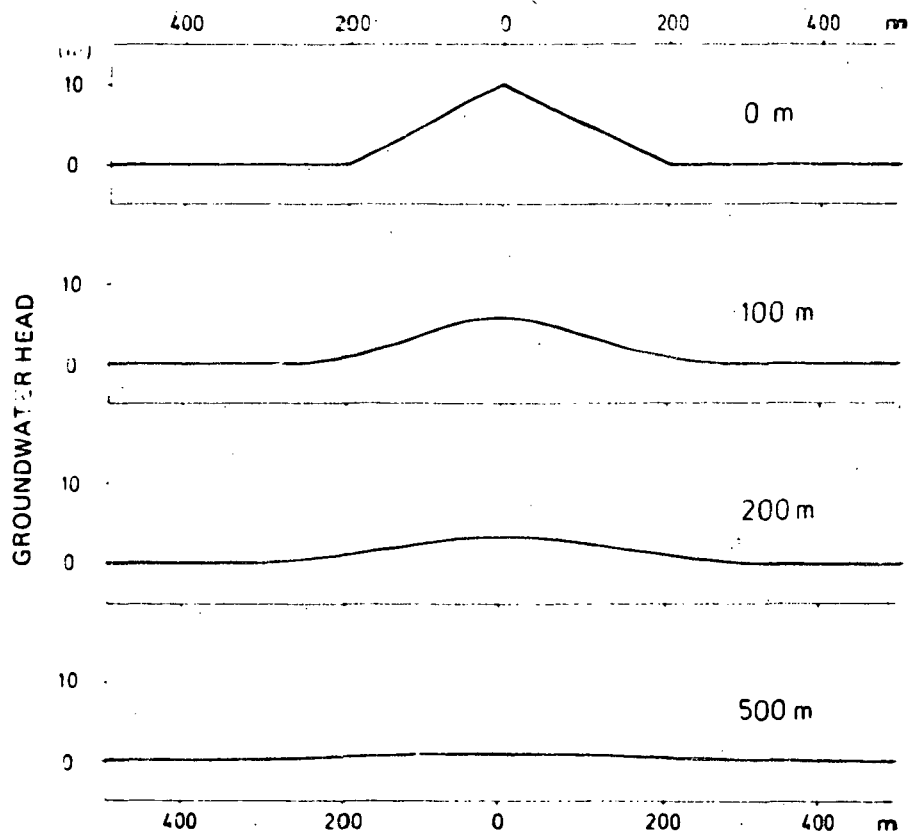

Figure 2.2: Groundwater head at different depths below a circular hill with a 200 m radius. Hydraulic conductivity decreases with depth (after Carlsson et al 1983).

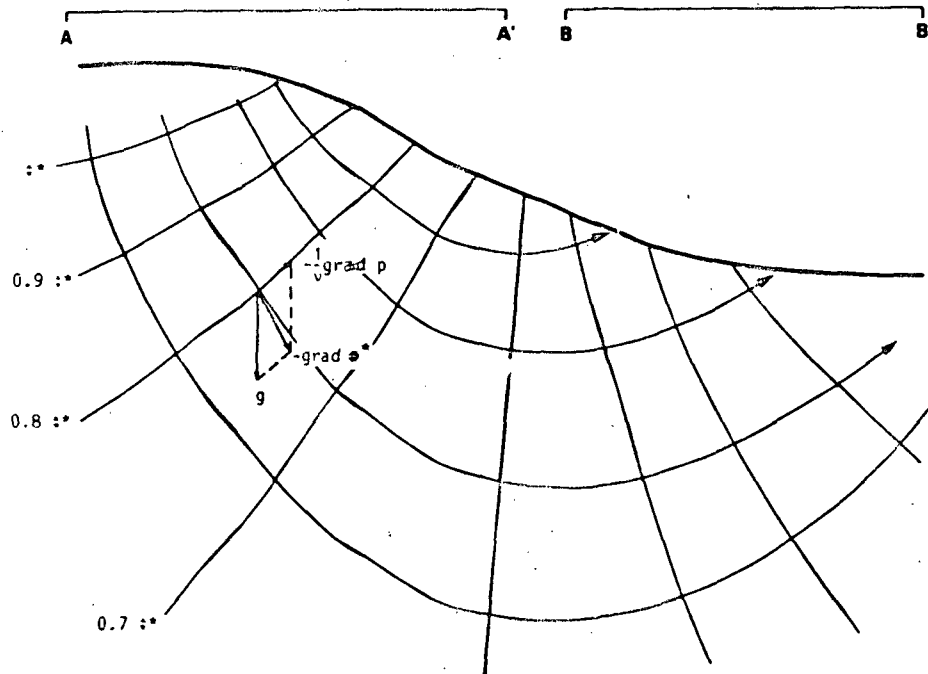

Figure 2.3: Two-dimensional theoretical potential distribution and flow-pattern in a homogeneous porous medium.

Thus, for isotropic media ($K = \text{constant}$) the velocity vector \underline{V} and the direction of flow is perpendicular to the equipotential surfaces ($\phi^* = \text{constant}$). These principles are illustrated in Figure 2.3. If the medium is anisotropic the velocity becomes oblique to ϕ^* -surfaces.

As shown in Figure 2.3 the direction of groundwater flow is downwards in the elevated parts of the terrain (A-A') and upwards in the lower parts (B-B'). The former are referred to as recharge areas and the latter discharge areas. In the recharge areas the hydraulic head, h , or the force potential, ϕ^* , is decreasing with increasing depth while the opposite situation is prevailing in the discharge areas. Thus, the flow is directed from high to low potentials. It can also be seen that the groundwater flowing from the lowest part of the discharge area has

migrated from deeper in the bedrock and over a much larger distance than groundwater seeping out at higher elevations in the slope. This implies that the oldest groundwater is to be found in of the valley bottom. This phenomenon is further accentuated if the hydraulic conductivity decreases with increasing depth, which is a general feature in crystalline bedrock.

To apply Darcy's Law it is assumed that the hydrogeological medium is homogeneous and uniformly porous. However, even though these properties are not normally characteristic of a crystalline rock environment, this concept can still be used if the number of fractures relevant for describing the groundwater flow provide a great enough density to justify a porous medium approach. Based on criteria discussed by Long et al (1982), a fractured crystalline rock can be regarded as an equivalent porous medium when:

- there is an insignificant change in the value of the equivalent hydraulic conductivity with a small change of the test volume (Figure 2.4)
- an equivalent symmetric hydraulic conductivity tensor exists which predicts the correct flux when the direction of hydraulic gradient (in a REV) is changed.

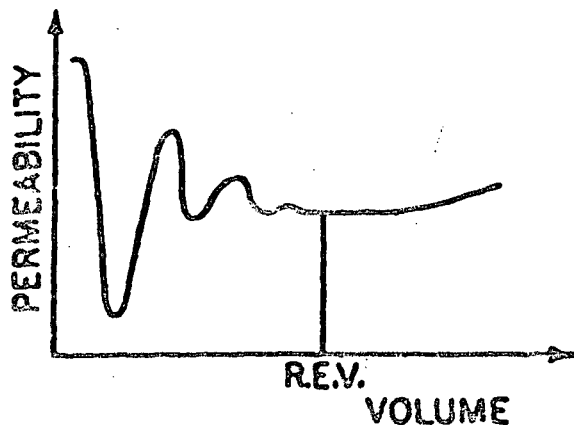

Figure 2.4: Statistical definition of a representative elementary volume (REV). (After Long et al 1982).

The first criterion implies that the hydraulic conductivity in a chosen test volume is a constant (i.e. homogeneous test volume). The second criterion implies that the hydraulic conductivity (in a three-dimensional flow) is a symmetric anisotropic parameter and that the boundary conditions are chosen in such a way that in a truly homogeneous anisotropic test volume a constant hydraulic gradient would be produced. Furthermore, fracture systems behave more like porous media when: 1) the fracture density is increased, 2) the considered volume is expanded, 3) the variation in fracture apertures is small and, 4) the fracture orientations are disturbed rather than constant (Figure 2.5).

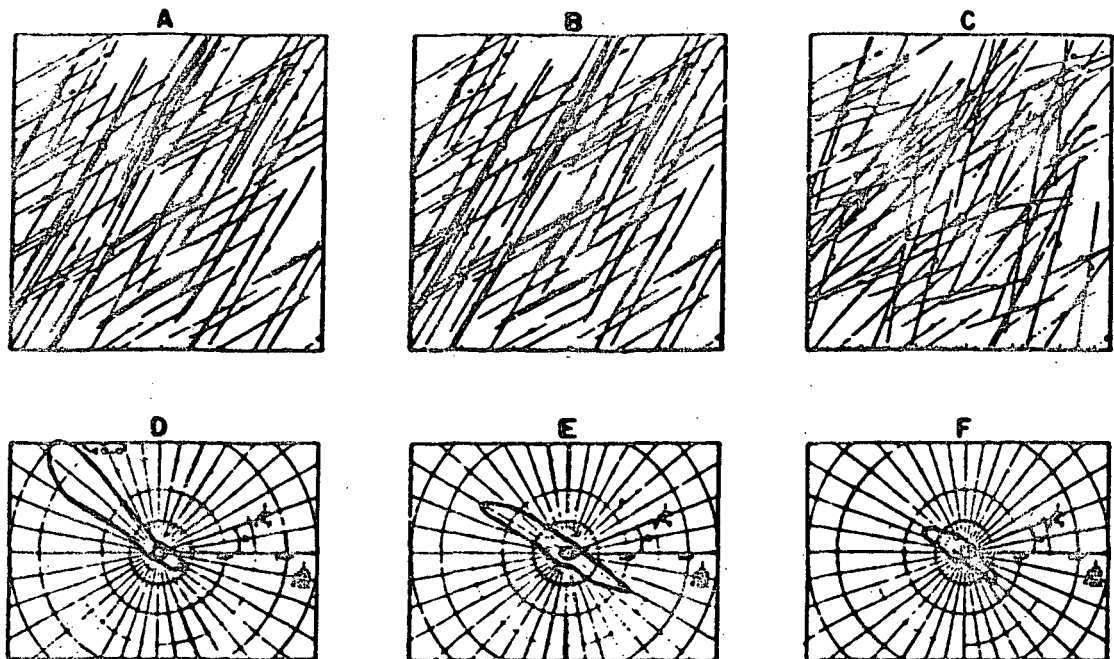

Figure 2.5: Fracture systems with varying parameters (30x30 cm). For A, fracture apertures are log normally distributed, for B, fracture apertures are uniform but with two different orientations, for C, fracture orientations are normally distributed, for D to F, the resulting distributions of hydraulic conductivity are shown (after Long et al 1982).

On the other hand this porous medium concept is not suitable if the distribution of the fractures, together with their respective lengths and apertures, are such that the flow properties of an area are dominated by the largest fractures surrounding and traversing the area (Stokes, 1980). Because of their great influence on the hydraulic head distribution and thereby on the groundwater flow-rates, the presence of such divergent fractures, or more commonly, concentrations of fractures (i.e. fracture zones), must therefore be treated as discrete elements in any model. The groundwater flow paths will naturally be mostly confined to the fracture zones as the resistance to flow in these high-conductive channels is relatively small when compared to the surrounding low-conductive, normally fractured bedrock.

However, the effects of such fracture zones on groundwater flow-rates are also dependent on the orientation of the zones. More or less vertically dipping fracture zones of relatively high hydraulic conductivity tend to decrease the change of hydraulic head and consequently maintain the hydraulic gradient to great depths, thus increasing the flow-rate. Contrastingly, horizontal or sub-horizontal fracture zones act as semi-impervious layers through which only a small flow occurs. As most of the flow will be directed along these horizontal zones, the flow-rates at greater depths tend to become diminished (Carlsson et al 1983) (Figure 2.6).

2.2 Chemical Parameters

Radionuclide mobility and the lifespan of the waste canisters for nuclear waste are strongly affected by the hydrochemical properties of groundwaters. The redox condition, pH, and the concentrations of metal complexing ligands such as carbonate-, fluoride-, chloride-, sulphide- and phosphate -ions, fulvic acids etc are the most important chemical parameters for determining radionuclide mobility and corrosion rates of the copper

canisters. Copper is a stable metal under reducing conditions and the solubility and mobility of most actinides are expected to be low in a naturally reducing environment. Sulphide, on the other hand, will react with copper and make copper oxidation with water possible despite the reducing conditions. Very large concentrations of chloride ions may have similar effects. Complexation with carbonates can for instance increase the solubility of uranium.

The chemical and flow characteristics of the groundwaters can be used to model the history of the waters and predict future changes in composition and flow pattern. A very simplified static model recognises deep ground water, near-surface water and a mixing of these two types. Here the surface and near-surface waters are considered to have a fairly uniform composition. This arises because the near-surface water obtains its character through mixing along its flow-path. The composition is then mainly determined by the hydraulic

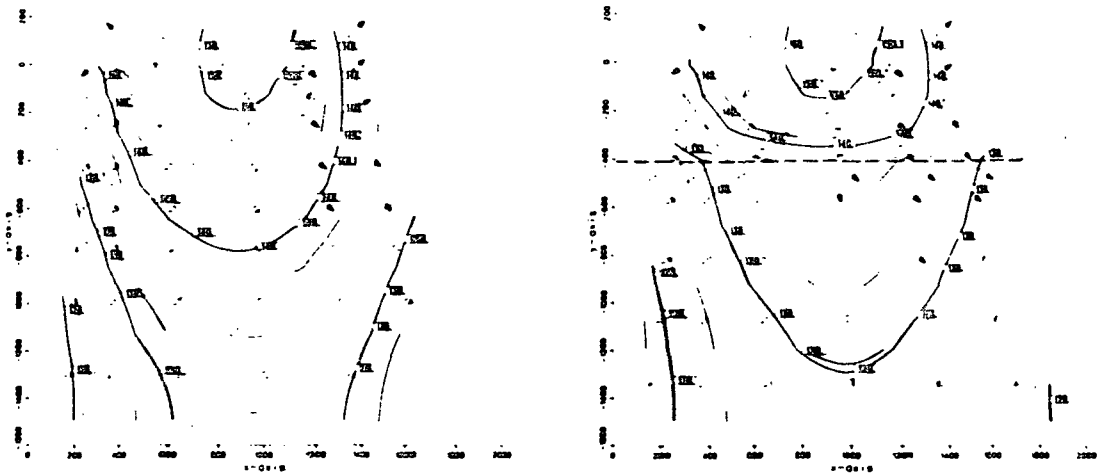

Figure 2.6: Modelled isopotentials and projected flow vectors along a vertical section from the Kamlunge test-site in N. Sweden (after Carlsson et al 1983). The dashed horizontal line denotes a fracture zone.

properties and conditions of the bedrock (e.g. flow-rate) and not by the chemical interaction between the water and the rock-forming minerals. In contrast, at greater depths, the groundwaters tend to permeate slowly through the bedrock which is more conducive to rock/water interaction. Groundwater composition is therefore more dependent on the local bedrock mineralogy.

The near-surface and deep ground waters are best distinguished from each other by pH and the total salt and carbonate contents. Shallow waters are rather dilute with a high carbonate content and neutral pH.

Groundwaters have a much higher pH, much higher sodium and chloride contents, but lower carbonate contents. The salt content of very old groundwater is sometimes extremely high with no apparent upper limit for the salinity. The source of the salinity is sometimes debatable with seawater, fluid inclusions and rock/water interactions all having been proposed as possible sources.

Environmental isotopes (e.g. ^2H , ^3H , ^{18}O , ^{14}C) provide a very useful hydrochemical tool in modelling ground water history. A cross plot of the stable isotopes deuterium and ^{18}O will reveal the origin of the water, i.e. meteoric or otherwise. The radioactive isotopes ^{14}C and tritium are suitable for recognising very old and very young portions of water respectively.

2.2.1 General groundwater chemistry

Within the SKB test-site programme a complete set of chemical analyses has always been carried out on the water samples. However, only some of these analysed parameters are essential to site evaluation and safety assessment considerations. These are pH, carbonate, chloride, sodium and calcium contents and the redox

sensitive parameters Eh, iron species, uranium, sulphide and oxygen.

pH and carbonate content

The pH of the water determines the form of the species in solution and is also a useful parameter for describing the type of water that is investigated. Near-surface groundwaters are mostly neutral with a pH of seven or slightly lower and deep groundwaters are usually characterised by a high pH; in some cases values above nine have been obtained. In near-surface waters the pH is solely buffered by the carbonate system whereas other salts contribute to the buffering capacity of the deep groundwaters.

The carbonate content of the water is important as the CO_3^{2-} ion is a very strong complexing agent for the actinides, appearing as soluble carbonate complexes in the groundwater. The total carbonate content is highest in the near-surface waters and decreases with depth, i.e. as the water becomes older.

Surface waters percolating through the soil zone take up carbon dioxide eventually becoming slightly acidic and aggressive. As a consequence, this water dissolves calcium carbonate when it penetrates to the upper part of the bedrock. Here the system is still open to the input of carbon dioxide with the result that the $\text{CO}_2\text{-HCO}_3$ system determines the pH giving a value of seven or just above. From about 100 m depth in the bedrock the system is no longer open to the input of carbon dioxide and the pH rises to a value around 8.5. In still deeper parts of the bedrock the groundwater flow is extremely low and the more slowly dissolving minerals will begin to have an impact on the composition of the water. Dissolution of feldspar will increase the pH which in turn will cause precipitation of calcite. The more advanced these

reactions become, the higher is the pH and the lower is the carbonate content.

Sodium, calcium and chloride content

The amounts of sodium, calcium, chloride and bicarbonate dissolved in near-surface waters and groundwaters are useful parameters in assessing the migrational history of the waters. For example, surface to near-surface waters tend to be calcium - bicarbonate in type whereas intermediate to deep groundwaters are of a sodium - calcium - chloride nature.

Near-surface and shallow groundwaters are characterised by high concentrations of calcium and bicarbonate due to the dissolution of calcite. As the flux decreases in the deeper parts of the rock the more slowly dissolving minerals (e.g. feldspar) will result in an increase of pH and in the sodium and chloride concentrations. Even when the amount of carbonate decreases due to the precipitation of calcium carbonate, the calcium concentration remains at appreciable levels indicating an input of calcium coeval with the increase in the sodium and chloride concentrations.

Redox-sensitive parameters

The redox condition of the groundwater is one of the most important parameters for estimating the safety of a nuclear waste repository. For example, if the actinides (i.e. released through canister corrosion) are assumed for modelling considerations to migrate in a reduced form through the geosphere, the radiation dose released to the biosphere will be two orders of magnitude lower than in the case where the actinides are transported in an oxidised form.

The redox condition of the groundwater is reflected by the measured redox potential, the amount of dissolved oxygen, and by the contents and oxidation states of the elements iron, sulphur and uranium. From all the various redox couples present in the groundwater it is possible to calculate a redox potential. However, these calculations would give as many different results as the number of redox couples used for the calculations. This simply indicates that no true redox equilibrium exists in the water. The reason for this might be a relatively late mixing of different types of water, but could also reflect the large uncertainties in the analytical data.

Oxygen is a very strong oxidant in the Eh-region of interest for the groundwaters. Small amounts of oxygen dissolved in the water will drastically affect the Eh measurements. Oxygen reacts rapidly with sulphide which means that these components should not be expected to be found in the same water sample. The existence of measurable amounts of sulphide in the water is an indicator of very reducing conditions. The sulphide is oxidized to sulphate by dissolved oxygen whereas the opposite reaction only occurs in the presence of bacterial activity.

As a word of warning, Eh and O_2 monitoring in the flow-through cells should be treated with some caution. In contrast to the contents of dissolved species in the sampled water, the Eh and O_2 contents are not solely characteristic of the groundwater, but are severely affected by atmospheric O_2 during calibration. Each time the cells are opened for electrode calibration, subsequent Eh measurements are disturbed for periods of up to several days before stabilising. Before this effect was appreciated, many cases therefore exist whereupon inadequate time has been available for the measuring electrodes to stabilise, and for the atmospheric-derived O_2 to be effectively removed from the flow-through cells.

The Fe(II)-Fe(III) couple is thought to be the prime redox determining reaction in most natural groundwaters (Wikberg et al 1983). The theoretical calculations of the Eh should be based on this system because the reactions between the ferrous and ferric iron at the electrode surfaces are reversible, the exchange current density is high and the rock contains some 1-10 % iron, most of it in the divalent form. However, in specific cases the Eh can be controlled by other elements. The remaining important redox sensitive parameter, that concerning the behaviour of uranium, is described below. (Section 2.2.2).

2.2.2 Uranium investigations

The presence of dissolved uranium and its isotopic daughter decay products in surface waters, near-surface waters and groundwaters, is of particular interest in the context of high-level radioactive waste safety assessment considerations. Features of importance include:

- a) uranium is a naturally occurring radionuclide which exists, at least in small quantities, in all rocks and therefore in most contact groundwaters.
- b) because of its economic importance as a nuclear fuel, uranium prospecting methods are highly developed and very small quantities (<1ppb) can be measured with precision in groundwaters and rocks.
- c) as uranium is an important constituent of spent nuclear fuel, and because its chemical behaviour resembles closely the more harmful actinides such as neptunium and plutonium, the hydrochemical behaviour of uranium in the geosphere and under laboratory conditions, renders it extremely instructive in helping to predict long-term actinide behaviour in the far-field environs in the event of canister corrosion and subsequent radionuclide leakage.

d) the degree of uranium dissolution and mobility in groundwaters can be used as an important redox-sensitive parameter.

Uranium geochemistry

Uranium dissolution and mobility have over the years been subject to extensive study both in the laboratory and in the field (see, for example, Hostetler and Garrels, 1962; Osmond and Cowart, 1976; Langmuir, 1978; Giblin et al 1981). From such studies an extremely complex picture has emerged which shows that many physico-chemical parameters can influence the behaviour of uranium in natural groundwaters. Based on Langmuir (1978) and Giblin et al (1981) the major influencing parameters are listed below.

- a) the uranium content in the source rocks and its leachability.
- b) the proximity of groundwater to uranium-bearing rocks and minerals.
- c) concentrations in the groundwaters of carbonate, phosphate, vanadate, fluoride, sulphate, calcium, potassium and other species which can form uranium complexes or insoluble uranium minerals.
- d) the sorptive properties of materials such as organic compounds, oxyhydroxides of iron, manganese and titanium, and clays.
- e) pH and Eh states of the groundwater environment.
- f) redox state of the uranium species.
- g) kinetics of uranium speciation reactions.
- h) rates of groundwater mixing and circulation.

However, this list need not be so formidable as it appears because only a few need to be considered in modelling the behaviour of uranium in groundwaters. These are pH, Eh and the total concentrations of the ligands which form complexes of relative strength with uranium in its different oxidation states, i.e. carbonate, biophosphate.

Under strongly reducing conditions the solubility limiting phase would be UO_2 (solid) in either crystalline (i.e. uraninite) or amorphous (i.e. pitchblende) form, depending on the environment. The characterisation of the uranium species present in solution is however less clear. The U(IV) hydrocomplexes $\text{U}(\text{OH})_4$ and $\text{U}(\text{OH})_5$ have been postulated as being responsible for the UO_2 (solid) solubility in carbonate-free alkaline environments (Allard, 1983). However later studies by Rai et al (1984) and Ryan and Rai (1983; 1984) have disproved the possibility of $\text{Ac}(\text{IV})(\text{OH})_5$ (were Ac = the actinides U, Np, Pu). As a result only $\text{U}(\text{OH})_4$ need be considered in reducing carbonate-free environments.

Under less reducing conditions, and/or in the presence of carbonate, the uranyl carbonate species $\text{UO}_2(\text{CO}_3)_2^{2-}$ and $\text{UO}_2(\text{CO}_3)_3^{4-}$ predominate. Depending on the degree of crystallisation of UO_2 (solid) and the oxidation conditions of the surrounding environment, uraninite is no longer the solubility limiting phase. Instead, $\text{UO}_2(\text{OH})_2$ (solid) will control the uranium content in solution (Bruno, 1984). At the pH values usually found in groundwater systems, the U(VII) biophosphate complex formation can also play an important role. The relative occurrence of U(VI)-phosphate complexes vs carbonate complexes increases as pH decreases from 8 to 6.5. Under more acidic conditions fluoride, sulphate and hydroxy complexes will be the dominant species.

The total uranium solubility, and as a consequence its mobility, can be restricted by the possible ternary species which can be found in a multivariant groundwater system. The effect of mixed crystalline solids such as carnotite $K_2(UO_2)_2(VO_4)_2$, uranophane $Ca(UO_2)_2(SiO_3OH)_2$, autinite, $Ca(UO_2)_2(PO_4)_2$, bassetite $Fe(UO_2)_2(PO_4)_2$ etc has been observed in natural environments. Thus, complete modelling of uranium, which is beyond the scope of this present report, should include these species, even if the present state of knowledge regarding the thermodynamic parameters involved are somewhat restricted at this time.

Experimentally-derived conclusions are generally borne out by geological observations. These show that tetravalent uraninite remains immobile under reducing conditions but slowly mobilises during increased exposure to atmospheric conditions or to oxygen/carbon dioxide-bearing groundwaters. Furthermore, and an important point, is that the solubility of low temperature amorphous UO_2 (e.g. pitchblende), which is considerably greater than that of crystalline uraninite, can also occur under more reducing conditions than the more stable uraninite. It is therefore important to correctly assess the hydrogeological features of an area under investigation before applying experimentally-based hydrochemical data. For example, Andrews and Kay (1983) suggested that crystalline UO_2 stability field boundaries were more appropriate for groundwater equilibrium with rock matrices containing well-crystallised UO_2 (i.e. uraninite), as would be associated with some granite environments. Contrastingly, for certain sedimentary environments, uranium deposition in the absence of crystalline nuclei would tend to preferentially form disordered or amorphous UO_2 (i.e. pitchblende). In these cases amorphous UO_2 stability-field boundaries are recommended. However, depending on the Eh-pH parameters of groundwaters representative of the two geological environments, the uranyl carbonate complexes may be stable in the aqueous phase thus

restricting any uranium precipitation. Such a situation has been described in groundwaters from Triassic sandstones (Andrews and Kay, 1983) whereupon in the absence of uranium deposition, some of the highest uranium contents were recorded from those groundwaters which generally exhibited the lowest Eh values. Of-course it is important to note here that a realistic interpretation of natural groundwater data based on thermodynamic models is dependent on the confidence of groundwater Eh measurements. Such confidence is often debatable.

Nevertheless in general terms, natural groundwater uranium concentrations tend to be relatively high (>10ppb) in an oxidising environment, and correspondingly low (<1ppb) beyond the oxidation-reduction interface, and that Eh, pH and total carbonate concentrations are the dominating controlling parameters. Therefore, to use raw uranium values as a direct indication of the redox state of a groundwater environment should be treated with some caution, until the physico-chemical characteristics of the groundwaters are known.

Uranium isotope geochemistry

The uranium decay series (^{238}U - ^{234}U - ^{230}Th) has been increasingly used to characterise groundwaters and rocks (Rosholt, 1959, 1983; Thurber, 1962; Rosholt et al 1963, 1966; Koide and Goldberg, 1965; Kigoshi, 1971; Kronfeld, 1974; Osmond and Cowart, 1976; 1982 and Fleischer and Raabe, 1978). In closed geological systems the nuclides ^{238}U - ^{234}U - ^{230}Th attain radioactive equilibrium after about 1.7 Ma, i.e. the respective activity ratios $^{234}\text{U}/^{238}\text{U}$, $^{230}\text{Th}/^{234}\text{U}$ and $^{230}\text{Th}/^{238}\text{U}$ all equal unity. However, if the systems are exposed to weathering and groundwater circulation, and assuming that ^{230}Th is immobile under normal groundwater conditions, the different physico-chemical properties of ^{238}U and ^{234}U will

result in their fractionation and thus isotopic disequilibrium. The respective activity ratios will therefore be greater or less than unity depending on whether there is an excess or deficiency of ^{238}U and/or ^{234}U .

Applied to groundwater investigations, uranium-series disequilibrium studies should therefore indicate which radionuclides are being leached from the bedrock, and their subsequent behaviour during migration and transport through the rock mass. Owing to the generally assumed immobility of thorium in natural groundwaters (Langmuir and Herman, 1980), the isotopic signature is normally expressed using the $^{234}\text{U}/^{238}\text{U}$ activity ratio. Because groundwaters are rarely static over periods of geological time, the addition and loss of nuclides will be variable depending on the changing physico-chemical properties of the groundwaters as they permeate through bedrock of contrasting chemistry and at different depths. As a result, the $^{234}\text{U}/^{238}\text{U}$ activity ratios invariably show isotopic disequilibrium. $^{234}\text{U}/^{238}\text{U}$ disequilibria have thus been used to characterise water masses, estimate degrees of mixing of different water masses, estimate the intensity of water circulation and as a means of dating groundwaters (e.g. Osmond et al 1974; Kronfeld et al 1975; Osmond and Cowart, 1976).

Well-documented work on large-scale sedimentary aquifer systems (e.g. Kaufman et al 1969; Osmond and Cowart, 1976; Cowart, 1980; Andrews and Kay, 1982) have indicated that during the transition from an oxidising to a reducing environment, there occurs a decrease in total dissolved uranium (discussed above), and an increase in the $^{234}\text{U}/^{238}\text{U}$ activity ratio. It has been suggested (Osmond et al 1974) that such a build-up of ^{234}U with depth indicates an aging effect due to the natural decay of the parent ^{238}U . However, as summarised by Andrews et al (1982), uranium in solution does not form a closed system and ingrowth of ^{234}U

occurs due to solution of alpha-recoil ^{234}Th at the rock/water interfaces during permeation of the groundwaters. In addition, the ultimate extent or excess of ^{234}U and therefore the $^{234}\text{U}/^{238}\text{U}$ activity ratio value, is also dependent on the natural groundwater flow-rate and the possible interchange with active leaching waters. Furthermore, sampling procedures in which artificial groundwater flow-rates have been imposed, may also result in a modification of activity ratio values and total dissolved uranium contents (Smellie, 1983b,c).

It should therefore be recognised that, in common with the other environmental isotopes in routine use, uranium decay series studies of groundwaters should not be used in isolation, but rather as one more important factor to be considered in hydrochemical interpretation.

2.2.3 Environmental Isotopic Studies

Environmental isotopic studies of hydrologic systems mostly involve the light elements and their isotopes: hydrogen (^1H , ^2H , ^3H), carbon (^{12}C , ^{13}C , ^{14}C), nitrogen (^{14}N , ^{15}N), oxygen (^{16}O , ^{18}O) and to a lesser extent sulphur (^{32}S , ^{34}S). These are normally chosen because isotopic fractionation between different isotopes of the same element, resulting from their differing geochemical and physical behaviours, is sufficiently large to be of geochemical interest. Of the heavier elements, the uranium decay series nuclides ^{238}U , ^{234}U , ^{226}Ra and ^{222}Rn exhibit significant measurable fractionation differences to be of use in hydrochemical studies. With greater instrumental sophistication, measurement and application of isotopes such as ^{129}I , ^{39}Ar , ^{85}Kr , ^{81}Kr and ^{36}Cl have increasingly been carried out with limited success.

Within the Swedish radwaste hydrochemical programme, and in most other countries, the major routinely applied isotopes have been tritium, radiocarbon and the stable isotopic ratios of D/H and $^{18}\text{O}/^{16}\text{O}$. Increasing use is being made of the uranium decay series isotopes (see above). Using such isotopic data, groundwaters can be characterised in terms of:

- a) identification of areas of static groundwater where regional migration of radionuclides should be minimal
- b) estimation of water velocities in circulating hydrologic systems
- c) groundwater source (s)
- d) degrees of mixing of groundwaters from different sources
- e) as an aid in predicting future natural changes in the chemistry of the groundwater
- f) an estimation of groundwater age

Only in very rare cases of extreme isolation and confinement can a groundwater be ascribed an age; most groundwaters when sampled are the products of mixing incurred either prior to, or during sampling, and so derivation of an age can be fraught with uncertainty.

Tritium

Tritium (^3H) is the radioactive isotope of hydrogen with a half-life of 12.4 years and is measured in tritium units. One tritium unit (TU) is defined as the concentration of one atom of ^3H in 10^{18} atoms of ^1H . Tritium is derived:

- naturally from the atmosphere by cosmic-ray radiation involving the interaction of nucleons with nitrogen, oxygen and argon. Through oxidation to water it eventually reaches the earth and groundwater systems through precipitation.

- naturally in the sub-surface by the induced reaction of neutrons (from the decay of U and Th in the bedrock) with ${}^6\text{Li}$ and ${}^4\text{He}$. Because of the near-absence of Li in groundwater, ${}^3\text{H}$ production can be neglected.
- artificially from the testing of thermonuclear devices in the period 1952-1962.

By far, most of the tritium present to-day in the atmosphere and subsequently in most surface and near-surface waters, is due to thermonuclear contamination. As the potential use of tritium as a hydrological tool has been mostly recognised during and after this event, there exists only a few pre-test tritium measurements available. However, enough is known to be able to derive some natural tritium levels in precipitation which range from 4 to 25 TU, depending on location (Nir et al 1966). As a result of the thermonuclear tests the tritium values increased dramatically reaching a peak of several thousands TU around 1963, and since then levels have decreased steadily to several tens TU, mostly through an inventory decrease of 5.5 % per year through radioactive decay.

The attraction of tritium as a hydrologic tool is its use in distinguishing between recent water (recharge after 1952) and older water (recharge prior to 1952) thus providing important information on, for example, groundwater recharge velocities.

Radfocarbon

The primary source of ${}^{14}\text{C}$ is the nuclear reaction between the secondary cosmic-ray neutrons and nitrogen nuclei which occurs in the transitional region between the stratosphere and the troposphere (Libby, 1965). These ${}^{14}\text{C}$ atoms eventually oxidise to form ${}^{14}\text{CO}_2$ molecules which, upon mixing with inactive atmospheric

CO_2 , subsequently enter the biosphere and hydrosphere in the form of CO_2 and HCO_3^- .

The chemistry of the CO_2 - CaCO_3 system for groundwaters in contact with the soil and bedrock, which comprise the surface and sub-surface environs, is complex. In a CO_2 - CaCO_3 open-system the carbonate (surface and sub-surface environs) is dissolved by water in continuous contact with the CO_2 reservoir (the soil CO_2) at a fixed partial CO_2 pressure. In the closed-system case, the carbonate is dissolved by infiltrating water which has initially been in contact with the CO_2 reservoir. In nature however, nothing is ever so simple and carbonate dissolution will more than often take place under mixed conditions. Furthermore, when the groundwater becomes supersaturated, the precipitation of ^{14}C -enriched calcite occurs under favourable conditions resulting in groundwaters correspondingly depleted in ^{14}C . As argued by Tullborg (1985), to be able to discuss the relevance of groundwater ^{14}C dating, it is important to know whether dissolution or precipitation of calcite is prevailing at the sampled levels. These complexities mean that it is often difficult to reconstruct the original carbon-14 content of the water. The ratios of the two isotopes of carbon (^{12}C and ^{13}C) vary considerably in nature and their ratios are widely used to help unravel the geochemical history of the groundwater and to estimate the original amount of ^{14}C introduced into the system. Because of these uncertainties, and others which include chemical and isotopic exchange with atmospheric CO_2 , all of which must be corrected for, the characterisation of groundwaters by the ^{14}C technique is treated with some doubt.

To combine ^{14}C and ^3H data in conjunction with hydrogeological evidence has in some circles been considered more appropriate (Eriksson, 1962; Geyh, 1972), thus enabling water sources to be located and also as a

validation of certain correction procedures. Dating of relatively recent water (last 50 years) is also possible. However, because of the large number of unknown variables, many reservations still remain. As summarised by Mook (1980; p. 70) such variables include:

- 1) the mixing ratio of old and young water,
- 2) the tritium content of the precipitation to which the sample refers,
- 3) the ^{14}C content of the humus layer effective in producing the soil CO_2

To conclude, the ^{14}C method should not be over-emphasised in terms of providing concrete evidence, but rather as a sometimes important "sign post" to the origin and characterization of a groundwater system.

Oxygen and deuterium

The oxygen isotopes (^{17}O and ^{18}O) and deuterium (^2H) occur naturally in water and are stable to radioactive decay. Due to natural processes such as phase transitions, water transportation, chemical and biological reactions etc., isotopic fractionation occurs resulting in a distinct isotopic signature for groundwater deriving from different sources. Variations in isotopic abundance is not thought to be adversely influenced by presently-occurring radiogenic production in the atmosphere. All of these factors render such isotopic measurements as extremely useful in characterising surface, near-surface and groundwater environments. As summarised by Fontes (1980; p. 75), "if the isotope content does not change within the aquifer, it will reflect the origin of the water. If the isotope content changes along groundwater paths, it will reflect the history of the water. Origin deals with location, period and processes of the recharge. History deals with mixing, salinisation and discharge processes".

For practical purposes the stable isotopes ^2H and ^{18}O are used to distinguish water originating from different sources in the assumption that they remain unchanged from recharge to groundwater-flow conditions. The initial stable isotope concentration in water is basically controlled by:

- a) condensation stages resulting in precipitation; this tends to result in isotopic fractionation and depends on changes of temperature and pressure.
- b) subsequent evaporation stages; this tends to result in an increase in isotopic content of the residual water and depends on the relative humidity.

Stable isotope values for waters are plotted on a ^2H (ppt) vs ^{18}O (ppt) diagram and interpreted relative to present day oceanic precipitation which is characterised by a deuterium excess (d) of 10 ppt. This is represented graphically by a linear relationship expressed by $\delta^2\text{H} = 8 \delta^{18}\text{O} + 10$ (Craig, 1961). In general, a slope less than 8 (i.e. relative deuterium enrichment) is indicative of water resulting from evaporation in an enclosed basin environment, whilst a slope greater than 8 (i.e. relative deuterium depletion) indicates changes in palaeoclimate.

However, the situation is not always quite so simple; for example, some groundwater stable isotope contents are sensitive to special hydrogeological and chemical circumstances:

- enrichment of $\delta^{18}\text{O}$ in water resulting from rock/water geothermal interactions
- enrichment of $\delta^{18}\text{O}$ and depletion of $\delta^2\text{H}$ in waters resulting from alteration of feldspars to clay minerals.

- gaseous exchange of CO_2 and H_2S from charged groundwaters can result in a depletion of $\delta^{18}\text{O}$ and enrichment for $\delta^2\text{H}$ respectively.

Nevertheless, in the majority of cases deuterium excess is a powerful tool for groundwater identification, in any case much safer than the study of only ^2H and ^{18}O contents. For example, such a limited study can be influenced by local conditions of recharge (e.g. exceptional rains or floods) without a significant change in general climatic conditions (Fontes, 1981).

3. INFLUENCE ON GROUNDWATER CONDITIONS BY BOREHOLE AND BOREHOLE ACTIVITIES

3.1 General

In order to carry out investigations of groundwater conditions in the bedrock, boreholes are required down to different depths. These holes are utilized for in-situ investigations such as single or crosshole measurements using hydraulic and geophysical testing procedures. In addition, water samples are taken from different levels in the boreholes for chemical, physical and isotopic analyses.

The hydraulic conductivity and other groundwater parameters vary considerably within the bedrock. Because of such variation, in combination with topographical and meteorological conditions, different hydraulic head will occur in the bedrock. Furthermore, a borehole which penetrates zones or areas of different hydraulic head will short-circuit the groundwater through the borehole. Thus, the groundwater will flow into the borehole from one or a combination of several horizons and out into the bedrock through others. Such conditions will influence both the hydraulic and the chemical situation in the bedrock at varying distances from the borehole.

Groundwater conditions in the bedrock will also be influenced by drilling and cleaning operations (gas-lift pumping). The drilling water pressure will result in an inflow of water into the bedrock. The amount of inflow and distances of influence are, among other things, dependent on the hydraulic properties of the bedrock surrounding the borehole. In particular the groundwater chemistry is influenced by these operations, but an influence on the hydraulic conditions might also occur from clogging of the borehole due to fine particles in the drilling fluid (drilling debris).

According to Ask and Carlsson (1984) the following activities are considered to be the main causes of influence on the groundwater:

- Borehole drilling
- Gas-lift pumping
- Hydraulic injection tests
- Water sampling
- Open-hole effect
- Drilling debris

Drilling and testing waters, which usually has a chemical composition diverging from the natural existing groundwater, are introduced into the borehole and the surrounding bedrock. Consequently the groundwater chemistry is influenced to varying degrees. Gas-lift pumping and water sampling on the other hand remove water from the borehole. However, under certain circumstances this might also result in waters with different chemical compositions replacing the water being sampled in the borehole.

The open-hole effect will act during long periods of time if the borehole is left open. By introducing a straddlepacker system, sections with different hydraulic head will be sealed off thus preventing a short-circuiting in the borehole. The disturbance caused by short-circuiting might under certain conditions influence the existing natural head distribution within a large area, the groundwater chemistry, and the turn over time in the system.

The different sources of influence just described usually occur in the following order when performing a site investigation (Ahlbom et al 1983a). First borehole drilling takes place followed by an initial gas-lift pumping to remove drilling debris and drilling fluid from the borehole. After being left open for a longer or shorter period of time during which short-circuiting of the groundwater exists in the borehole, the investigation

proper is carried out. First geophysical logging is conducted whereupon probes are lowered and raised within the borehole creating a mixture of the water within the borehole itself. Following that the hydraulic tests are performed, usually for a total duration of about one month for a 600 m long borehole. The borehole is then usually left again without any packers installed until the water sampling procedure is conducted. This sampling procedure starts with an extensive gas-lift pumping before the actual sampling procedure begins. The sampling time is about 2 weeks per sample-section and about 2 months for one borehole (see Section 4).

After the water sampling is completed, the borehole is finally left open without any packer-system.

3.2 Borehole drilling

3.2.1 Performance

In order to cool the drill bit during drilling and to remove drilling debris, flushing water (also referred to as drilling water) is used in the Swedish programme. This water is usually of a divergent chemical character from the groundwater in and around the borehole, and is continuously pumped down into the borehole under high pressure (2 MPa). Under such pressure this flushing water will be forced into the bedrock surrounding the borehole, thus affecting both the hydraulic and chemical parameters therein. These negative effects can be diminished by using shallow groundwater (of similar chemical character to that encountered whilst drilling) from a nearby air-flushed percussion hole.

The core-drilling operation consists of three phases: 1) the drill-rod with the drill bit and the core barrel are lowered into the borehole until the bottom is reached, 2) drilling starts with an applied excess pressure on the drilling water, 3) after having drilled a 6 metre section

the equipment is brought up to the surface and the drilled core is taken out and stored. Due to the displacement of the drill rod etc, the groundwater level in the borehole will be lowered during up-take and thus an inflow of water from the rock to the borehole occurs.

The time required for the initial drilling phase increases with drilling depth. The drilling time involved in the second phase varies depending on bedrock conditions and on the condition of the drill bit; on average 45 - 60 minutes is required to drill 6 m. The time required for the third phase also increases with drilling depth. As an example Figure 3.1 shows the relationship of total drilling time versus drilling depth for borehole Fj2 (Fjällveden) which is 700 m in length.

3.2.2 Influence on the groundwater

The borehole radius of influence on the groundwater conditions caused by the excess drilling fluid pressure is dependent on the hydraulic properties of the bedrock as well as on the excess pressure. It is also dependent on the effective drilling time - the time it takes to drill a certain distance - as well as the time it takes to empty the core barrel and lower it into the borehole again. During drilling the flushing water is injected a certain distance into the bedrock formation. When the drilling is stopped, the equipment raised and the core barrel emptied, the pressure is lowered in the borehole. This causes the drilling water to flow back into the borehole, thus decreasing its radius of influence. When the drilling commences again, the radius of influence will continue to expand, reaching the maximum at the end of the last drilling period.

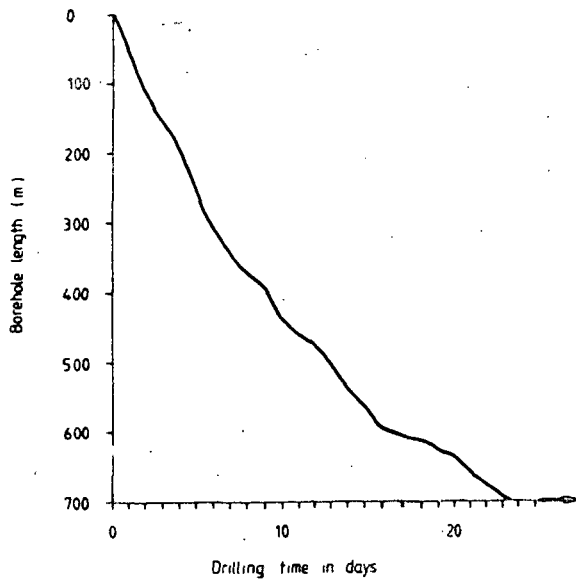

Figure 3.1: Drilling time versus depth for the borehole FJ2.

When the flushing water passes down through the drillrods the excess pressure is reduced by friction. The extent of this reduction is partly dependent on the flow-rate of the water and the diameter of the drill-rod, and can be calculated according to the universal law of resistance or Darcy-Weisbach's formula:

$$h_f = \zeta_d \frac{L}{d} \frac{v^2}{2g} = \zeta \frac{v^2}{2g} \quad (3-1)$$

where h_f = pressure reduction (m wc)
 ζ = resistance coefficient
 v = average velocity (m/s)
 g = acceleration due to gravity (m/s²)
 ζ_d = tube resistance
 L = tube length (m)
 d = tube diameter (m)

The drill-rods, which have an inner diameter of 37.5 mm and are 3 m in length, are connected by 0.2 m long couplings with an inner diameter of 22 mm. The average waterflow during drilling is 20 l/min. This implies that when calculating the pressure reduction, the influence of dimension changes must also be taken into consideration:

$$h_f = \zeta_1 \frac{v_1^2}{2g} + \zeta_2 \frac{v_2^2}{2g} + (\zeta_3 + \zeta_4) \frac{v_2^2}{2g} \quad (3-2)$$

where v_1 = velocity in the drill-rods

v_2 = " " " couplings

$\zeta_1 = 0.028 \times L/d$

$\zeta_2 = 0.027 \times L/d$

$\zeta_3 = (1 - d_2^2/d_1^2)^2 = 0.43$

$\zeta_4 = 0.5 (1 - d_2^2/d_1^2) = 0.33$

The first two terms refer to the pressure reduction due to flow in the rod and coupling respectively. The last term refers to energy losses due to eddying at the widening and contraction of the inner diameter. This gives a total pressure reduction of $1.6 \cdot 10^{-2}$ m/m. An additional pressure drop will occur at the drill bit.

Taking into consideration the actual drilling time, the excess water pressure and flow, a rough estimate to the amount of drilling water entering the bedrock can be carried out. The estimate is very rough and it is recommended to compare the results obtained by detailed measurements of flow and pressure during drilling.

The time for drilling 6 m is set to one hour. During this time an excess pressure of 200 m of water will prevail at the drilling section. Since the measurements of hydraulic conductivity are usually performed in 25 m sections, these longer sections are used as a base division of the borehole. Thus, in the 25 m section containing the actual drilling section, a full excess water pressure is assumed

to prevail. The overlying 25 m sections lying above have all a decreasing excess water pressure in accordance with a linear decrease. For instance, when the drilling has reached section 100-125 m, section 75-100 m is assumed to have an excess pressure of 0.8 times the excess pressure at the drilling section.

The water flow into or out of each 25 m-section of the borehole can be calculated by the following equation (Carlsson and Carlstedt, 1977):

$$Q = \alpha \cdot K \cdot L \cdot \Delta H \quad (3-3)$$

where Q = flow of water (m^3/s)
 α = parameter describing time and geometry (= 1)
 K = hydraulic conductivity (m/s)
 L = length of borehole section (m) ($L = 25$ m)
 ΔH = excess pressure in the borehole section (m)

The amount of water injected into the drilling section being considered can then be estimated by multiplying the flow-rate with the drilling time. However, the actual time of water injection during drilling of the 25 m section is estimated to be half of the actual drilling time. The remaining water flow will continue to the next section above where an estimate is carried out in the same manner. Thus, a step by step calculation is carried out and a summary of all steps will give an estimate of the total amount of water injected to the bedrock during drilling, disregarding any clogging effect and pressure drop at the drill bit.

Figure 3.2 shows estimates of the injected water into different 25 m sections of the boreholes Fj2 and Fj4 (Fjällveden test-site). Table 3.1 summarizes the estimates of the total inflow to the bedrock and the water balance for the drilling period.

Table 3.1: Estimates of the water balance during drilling of selected boreholes. Each borehole is 700–800 m in length.

Borehole	Estimated total use of flushing water during drilling. (m ³)**)	Calculated drilling water injected into the bedrock (m ³)	Drilling water returned to the ground surface (m ³)
Fj 2	135.0	134.9	0.1
Fj 4	135.0	134.9	0.1
Fj 7	125.0	3.3 *)	?
Fj 8	140.0	88.5	51.5
Gi 2	130.0	112.3	17.7
Gi 4	130.0	125.9	4.1
Km 3	130.0	130.0	-
Km 8			
Km 13	125.0	21.4	103.6
Kl 1	105.0	105.0	-
Sv 4	125.0	100.3	24.7
Sv 5	155.0	83.9	71.1
Ta 1	130.0	20.6	109.4

*) K-values are unavailable down to 125 m.

***) All measures are calculated on the assumption of a drilling water rate of 20 l/min

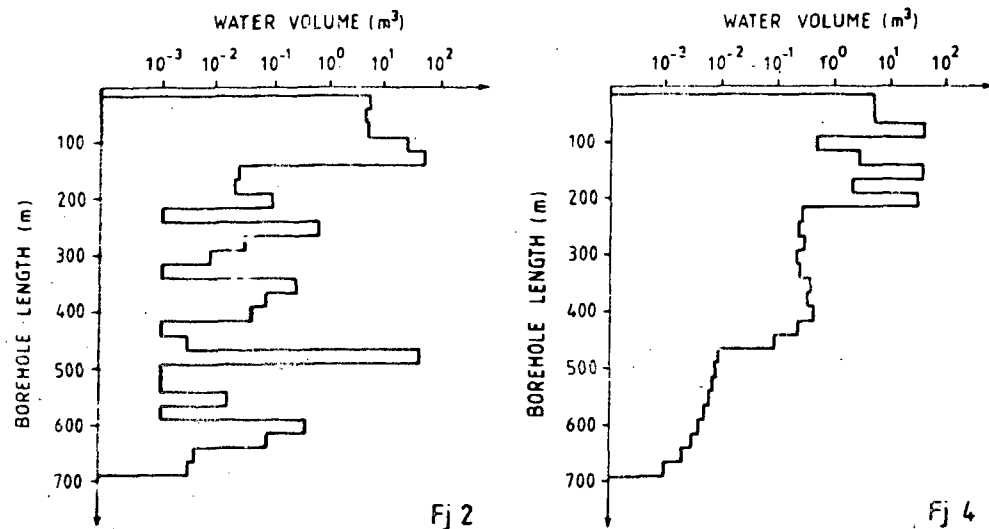

Figure 3.2: Estimated calculations of the amount of drilling water entering different 25 m sections during drilling of boreholes Fj2 and Fj4.

3.3 Gas-lift Pumping

After drilling is completed, the boreholes are cleared from rock debris and drilling water by gas-lift pumping. This is performed by introducing nitrogen gas down the borehole through a plastic hose and then forcing out the water and drilling debris. The nitrogen gas is introduced about 20 meters above the bottom of the borehole and no packers are used to seal off any particular sections in the boreholes. The initial pressure of the gas is 20 MPa. The gas will continue to flush the borehole until the pressure has dropped to about 8 MPa. After that there is a recovery period, during which the water level in the borehole rises to its maximum again due to the inflow of water from the rock. The flushing and recovery procedure is then repeated, in total usually 4 times during the complete cleaning operation after the drilling. The amount of water removed from the boreholes depends on the hydraulic properties of the rock. Usually it is about 4-5 m³ for each flushing period and thus 16-20 m³ in total for one borehole.

During drilling NaI (0.01 mmol/l) has been added to the drilling water (now superseded by uranine), to enable the tracing of any residual drilling water remaining in the groundwaters. As an estimate to the amount of remaining drilling water, samples are occasionally taken during the gas-lift pumping for rough analyses on the concentration of suspended particles and tracer.

The main cleaning operation is normally performed after completion of the drilling but prior to geophysical logging and hydraulic testing. However, additional cleaning is also performed in some boreholes before water sampling is conducted. The flushing is performed in the same way as described above and is usually repeated 3 times. Thus, the total amount of water pumped out of every investigated borehole is 28-35 m³.

3.4 Hydraulic Testing

3.4.1 General

Measurements of hydraulic conductivity are normally performed in the boreholes. These measurements, in the form of water injection tests, are carried out along different sections of the boreholes (diameter 56 mm). Usually 25 m sections are sealed off by means of inflatable rubber packers. In addition, sections of 2, 5 or 10 m are used in parts of the boreholes where fracture zones of interest are found. The lower measuring limit of the equipment used is $1 \cdot 10^{-11}$ m/s when performing 25 m section tests.

The tests are carried out as constant head water injection tests performed in three consecutive phases (Carlsson et al 1983):

- packer sealing (approx. 30 min.)
- water injection (approx. 120 min.)
- pressure fall-off (approx. 120 min.)

After the borehole section to be tested is isolated, a constant water pressure is applied. As a rule this pressure exceeds the existing natural water head by 0.2 MPa (20 m water column). The pressure is then measured in the test section and maintained at a constant value by regulating the water flow. The water flow is registered after commencement of water injection as a function of time. Assuming an outward radial flow from the test section, the flow can be expressed as:

$$Q(t) = 2\pi K L H G(\alpha) \quad (3-4)$$

where $Q(t)$ = flow as a function of time t (m^3/s)

K = hydraulic conductivity of the tested section (equivalent porous media) (m/s)

$G(\alpha)$ = well function at constant head

H = constant excess pressure in the tested section (m wc)

L = length of tested section (m)

$$\alpha = Kt/r_w^2 S_s \quad (3-5)$$

where r_w = borehole radius (m)

S_s = specific storage coefficient (m^{-1})

When the value of α is large, i.e. extended testing time and/or small values of r_w , $G(\alpha)$ can be approximated by $2/W(u)$, where $W(u)$ constitutes Theis's well function whereupon

$$u = 0.25/\alpha \quad (3-6)$$

For values of $u < 0.01$ ($\alpha > 25$) the well-function may be written as:

$$\begin{aligned} W(u) &= -0.5772 - \ln u = \\ &= 2.30 \log((2.25 K t)/r_w^2 S_s) \end{aligned} \quad (3-7)$$

Thus, without any skin-effect, equation (3-4) may be written as:

$$Q(t) = 5.46 K L H / \log((2.25 K t) / r_w^2 S_s) \quad (3-8)$$

The theoretical flow decrease might be influenced by factors associated with the borehole, the equipment and the bedrock (e.g. skin effect, equipment compliance and hydraulic variations). By using constant head testing, the effect of equipment compliance is reduced and by using transient testing it is possible in most cases to evaluate or estimate the influence of the disturbing factors.

In the third and last phase of the water injection test, the water flow to the test section is stopped and the pressure falls off. The hydraulic conductivity is calculated both from the injection and the fall-off phases.

3.4.2 Influence on the groundwater conditions

Water injected during hydraulic testing will influence the hydrochemical and hydraulic conditions of the groundwater. However, it is this change in hydraulic conditions that forms the fundamental concept for the hydraulic testing where the response of a controlled disturbance in the groundwater system is monitored and analyzed regarding the hydraulic properties and conditions.

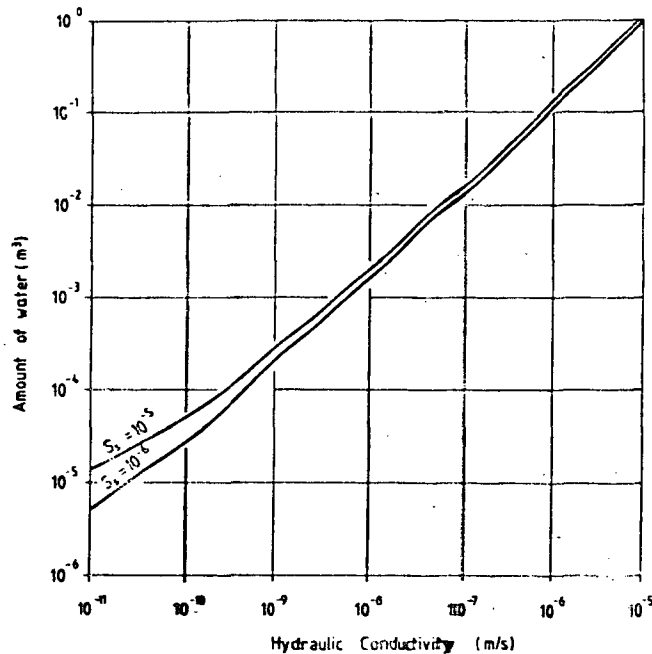

Figure 3.3: Amount of water injected during hydraulic testing as a function of the hydraulic conductivity for a one meter section with an excess pressure of 0.2 MPa and a testing time of 2 hours. (N.B. For explanation of the specific storage (S_s) see Section 3.6).

To estimate the influence of the hydraulic testing, the amount of water injected during the injection phase, and the area influenced around the borehole, have to be calculated. The amount of water injected is given by:

$$V = \int_0^t Q(t) dt \quad (3-9)$$

where V = amount of injected water during time t

By using equation (3-8) and (3-9) the diagram in Figure 3.3 is constructed. In the Figure the amount of injected water is given as a function of the hydraulic conductivity for an equivalent porous media with a test section of one meter length in a borehole with 56 mm diameter. The test duration is 2 hours and the excess water pressure is 0.2 MPa. Thus, at hydraulic

conductivities exceeding 5.10^{-9} m/s, more than one litre per metre test section is injected to the bedrock. It should be noted that the amount of water injected during the hydraulic testing is usually not removed from the borehole. During the recovery phase of the test the head will drop but no water is allowed to flow out from the borehole.

By using equations (3-3) and (3-9) and totaling the amount of water injected in each test-section of a borehole, the total amount of injected water to the borehole will be obtained. In Table 3.2 an estimation is given of the amount of water injected into the bedrock during the hydraulic testing in the sites considered in this report.

Table 3.2: Estimated amount of water injected into the bedrock during hydraulic testing along 25 m-sections at different test-sites.

Site/ borehole	Amount of water injected along 25 m sections (m ³)	Site/ borehole	Amount of water injected along 25 m sections (m ³)
Fj 2	3.0	Km 3	0.9
Fj 4	0.9	Km 8	1.0
Fj 7	0.1	Km 13	0.5
Fj 8	0.4	Km (13 holes)	12.0
Fj (9 holes)	6.9		
		Sv 4	1.0
Gi 2	2.5	Sv 5	1.7
Gi 4	2.2	Sv (6 holes)	8.0
Gi (13 holes)	24.0		
		Ta 1	0.3
		Kl 1	3.1

* Fj = Fjällveden; Gi = Gideå; Km = Kamlunge;
Sv = Svartboberget; Ta = Taavinunnanen; Kl = Klipperåsen.

3.5 Water Sampling

Water is sampled continuously from sealed-off sections in selected boreholes within each site. The sections are 2.7 m in length and sealed-off by rubber packers expanded to a pressure of 0.8-1 MPa above the groundwater pressure. In some cases samples are taken between one packer and the bottom of the borehole. The water is transported to the ground surface by a pump positioned above the sealed off section. The pump has a maximum capacity of about 330 l/day.

The sampling procedure is commonly performed during 14 days for each section. Details of the sampling procedure are outlined below in Section 4. The total amount of water pumped out from the boreholes during water sampling is summarised in Table 3.3.

Table 3.3: Total amount of water pumped out from the boreholes during water sampling at different test-sites.

Site/borehole	Total amount of water pumped out (m ³)	Site/borehole	Total amount of water pumped out (m ³)
Fj 2	13.7	Km 3	18.1
Fj 4	15.4	Km 8	>8
Fj 7	17.7	Km 13	11.8
Fj 8	4.0		
Gi 2	18.1	Sv 4	15.7
Gi 4	9.5	Sv 5	6.9
Ta 1	14.7	Kl 1	1.9

* Fj = Fjällveden; Gi = Gideå; Ta = Taavinunnen;
Km = Kamlunga; Sv = Svartboberget; Kl = Klipperåsen.

3.6 Open-hole Effect

3.6.1 General considerations

The mere existence of a borehole is a source of influence on both the groundwater chemistry and the hydrogeological conditions. This influence is due to the short-circuiting caused by the borehole itself on the naturally existing hydraulic head differences within the bedrock. These differences depend on the regional and local geological and topographical conditions within the actual area. In an open borehole short-circuiting will operate for a long time, affecting under certain conditions both the existing head distribution, the groundwater chemistry and the groundwater turnover time, within a large area.

The results from hydraulic testing and core-logging carried out within each site subdivides the bedrock into different hydraulic units. Currently, this subdivision recognises two types of fracture zones, regional and local, and the remaining rock mass (Ahlbom et al, 1983a). The results show that different hydraulic head exist in a borehole, but due to the borehole itself the groundwater level has equilibrated. However, the groundwater will still continue to circulate in the borehole, flowing from zones of higher hydraulic head to zones of lower hydraulic head. Under ideal conditions, with a constant groundwater level, the amount of water entering the borehole should be equal to the amount removed. This circulation will affect both the hydraulic and the chemical situation in the bedrock surrounding the borehole.

In order to illustrate the conditions mentioned, a series of theoretical models are treated, starting with the simple case of an unconfined aquifer above and a confined aquifer below an impervious layer. In this case groundwater will flow through the borehole from the zone of higher to the zone of lower hydraulic head, and the

groundwater level in the borehole will be situated somewhere between the two different piezometric levels. The amount of flow (Q) is determined by the difference in hydraulic head and the hydraulic conductivity of the actual zones and can be calculated from Dupuit's formula:

$$Q = 2\pi K H \Delta s / \ln (R/r_w) \quad (3-10)$$

where Q = flow of water (m^3/s)
 K = hydraulic conductivity (m/s)
 H = thickness of the aquifer (zone) (m)
 Δs = head difference in the borehole (m)
 R = radius of influence (m)
 r_w = radius of the well (m)

As the flow from the zone of higher head (Q_1) is equal to the flow into the zone of lower head (Q_2) the equation becomes:

$$\frac{\Delta s_1 K_1 H_1}{\ln(R_1/r_w)} = \frac{\Delta s_2 K_2 H_2}{\ln(R_2/r_w)} \quad (3-11)$$

Defining $M = \Delta s_1 + \Delta s_2$ and $R^* = \ln(R_2/r_w) / \ln(R_1/r_w)$ the equation becomes:

$$\Delta s_2 / M = \frac{(R^* K_1 H_1 / K_2 H_2)}{(1 + R^* K_1 H_1 / K_2 H_2)} \quad (3-12)$$

The expression $\ln(R_2/r_w) / \ln(R_1/r_w)$ will probably not exceed 2 or fall below 1/2.

In Figure 3.4 a set of type curves is presented showing $\Delta s_2/M$ for different values of K_1/K_2 and H_1/H_2 . These curves show that the greater K_1 and H_1 become, compared to K_2 and H_2 , the closer to the higher piezometric level will the equilibrium level be. The models are described in detail in Appendix 1.

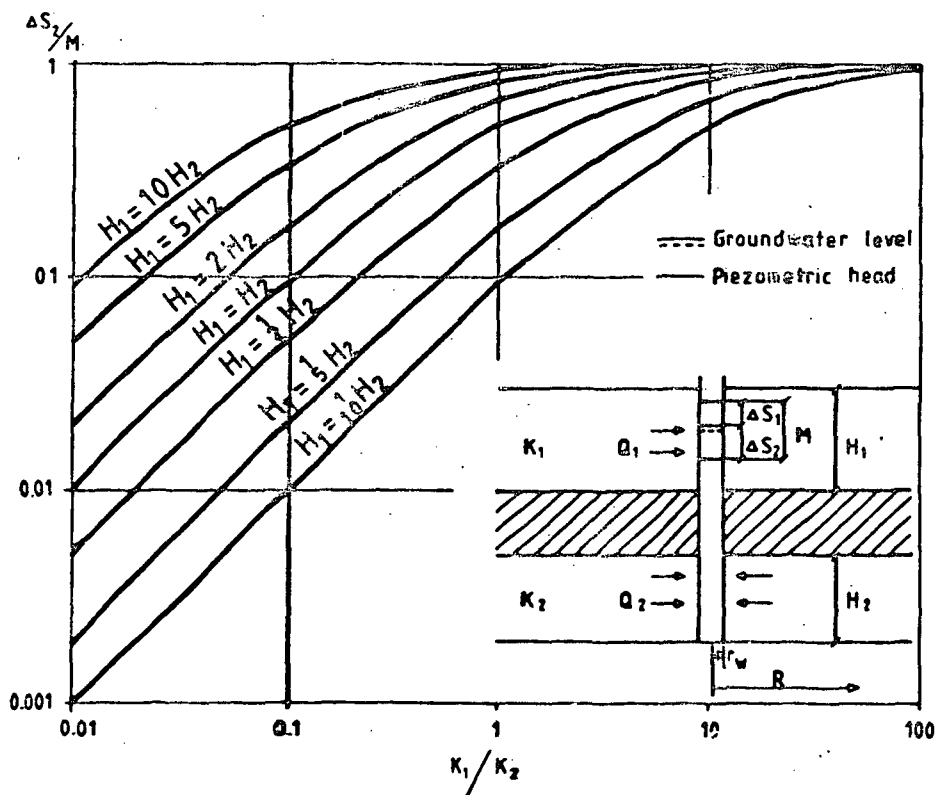

Figure 3.4: The relation between the resulting groundwater level (equilibrium level) and hydraulic conditions of two conductive fracture zones separated by an impervious layer. $\Delta s_2/M$ as a function of K_1/K_2 for different ratios of H_1/H_2 .

3.6.2 Numerical calculations

A generic model, based on geometrical data from the Kamlung site, is calculated by the finite element program GEOFEM-G (Runesson et al, 1979). The object is to illustrate the influence on the groundwater head of a borehole sited in the central part of a circular area having a diameter of 3.2 km. The area comprises a large hill with a relative height difference of 120 m surrounded by a "circular" fracture zone in the circumjacent valley. A section through the hill is given in Figure 3.5, where the boundary conditions used in the model calculations are also shown. The total depth of the calculated section is 1000 m.

The calculations are performed in a sequence comprising: 1) calculation without a borehole, 2) calculations only within a borehole, and 3) calculations when the borehole in the studied models is taken into account. In this section a brief summary of the results of the model calculations is described; for a more extensive presentation see Appendix 2.

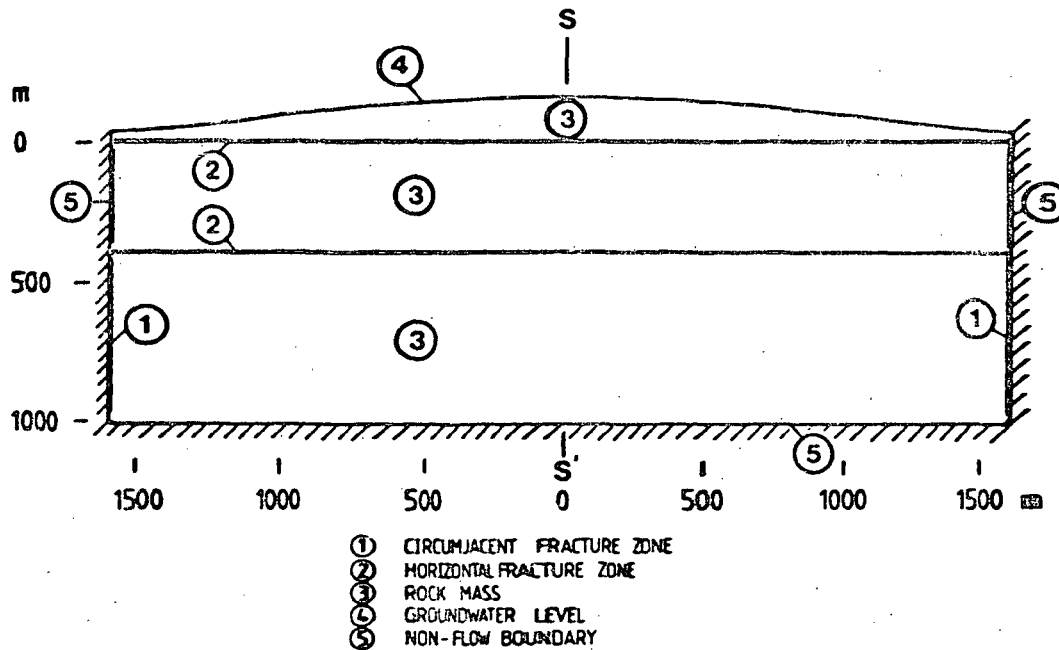

Figure 3.5 Section through the generic area modelled with boundary conditions given in the calculations.

Based on the boundary conditions given in Figure 3.5, the hydraulic head is calculated within the whole area studied. Four different cases are studied with different hydrogeological parameters and conditions as shown in Figure 3.6. In cases A and B, a constant hydraulic conductivity is allocated for the rock mass. In cases C and D the hydraulic conductivity decreases with depth according to the formula given by Carlsson et al (1983) for the Kamlunge site:

$$K = 7.91 \times 10^{-3} Z^{-3.17} \quad (3-13)$$

where Z is the depth below ground surface ($Z > 50$ m).

In cases B and D the influences are illustrated by two horizontal continuous fracture zones, with a thickness of 10 m each, which extend through the whole model. These fracture zones are given a hydraulic conductivity of $1 \cdot 10^{-7}$ m/s, while the outer limiting "circular" zone has a conductivity value of $1 \cdot 10^{-6}$ m/s.

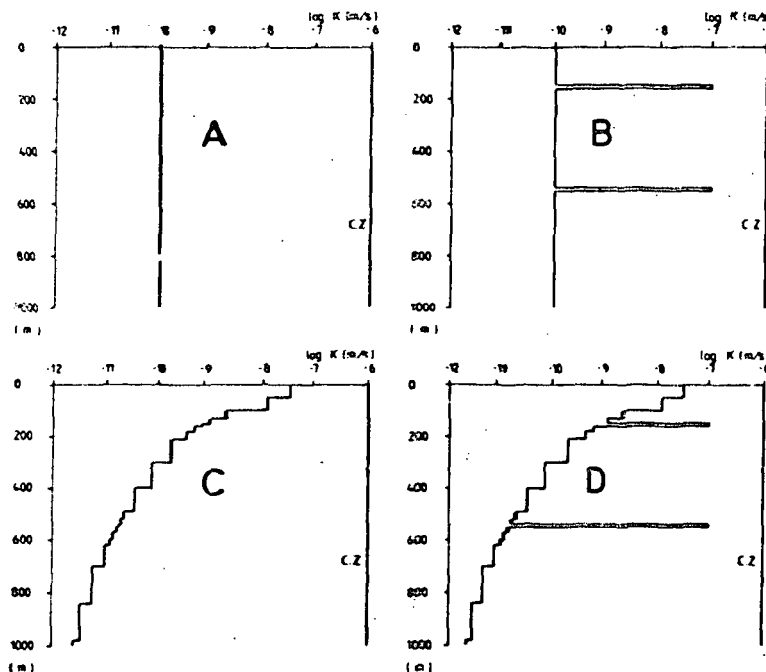

Figure 3.6 Hydraulic conductivity versus depth in the different cases studied. c.z. = circumjacent fracture zone.

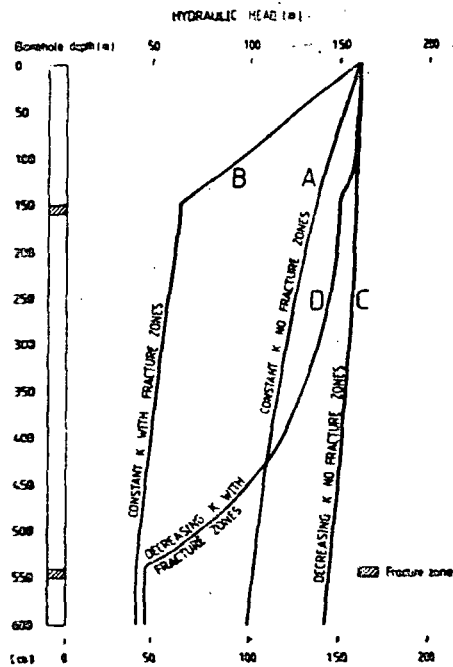

Figure 3.7: Groundwater head along the S-S' symmetry axis before the drilling (see Figure 3.5 for location of symmetry axis).

Along the symmetric line S-S' (see Figure 3.5), a borehole is drilled to 600 m depth. The groundwater head profile along the line before the borehole is drilled is illustrated in Figure 3.7 for the different cases considered. Based on these profiles the groundwater level within the borehole is calculated (Table 3.4) assuming that the water balance is maintained in the hole (i.e. constant groundwater level). Furthermore, the influence radius on the groundwater head from the borehole is assumed to be the same, regardless of the hydraulic conductivity value of the surrounding rock. The analytically calculated head for the different cases are shown in Table 3.4.

Table 3.4: Calculations of the groundwater level in a 600 m deep borehole sited in the centre of the studied model, and of the groundwater in- and outflow within the borehole. For the analytical and numerical calculations for different cases studied, see Figure 3.6.

Case	Calculated groundwater level (m below gw-level in the uppermost bedrock i.e. 160 m)	Annual exchange of groundwater within the borehole (m ³ /year)
A	36.3	9
B	106.1	190
C	0.3	10
D	28.6	1500

The second and last runs of numerical calculations comprise models where the groundwater level in the borehole is given as boundary conditions along the upper 600 m of the symmetry axis S-S'. To illustrate the influence on the hydraulic head orientated horizontally out from the borehole, two sections of head profile at 160 m and at 550 m respectively down the borehole are shown in Figures 3.8 and 3.9. In these figures the head increase or decrease in relation to the conditions before the borehole was drilled are given as a function of the radial distance from the borehole for the different cases considered under steady state conditions. The greatest influence is obtained in case D where horizontal fractures exist in the rock mass which has a decreasing hydraulic conductivity with increasing depth. In the case of constant hydraulic conductivity with depth (case A), a large head influence is also obtained. However, the distance of influence into the bedrock is greatest when horizontal fractures are present.

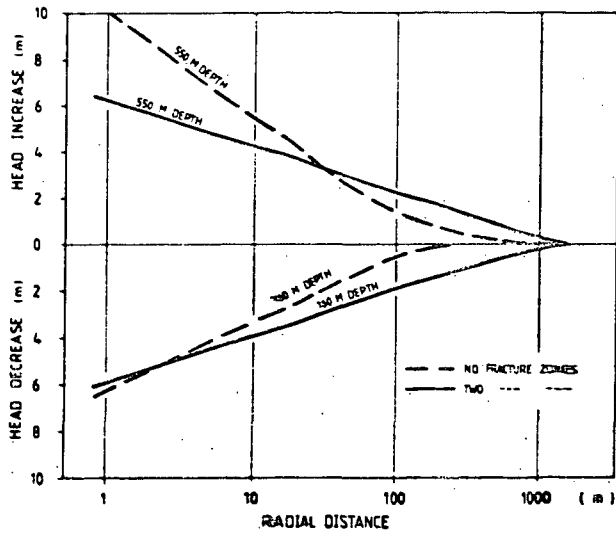

Figure 3.8: Groundwater influence due to the difference in piezometric head before and after drilling along a horizontal profile projecting from the borehole out into the bedrock (steady state). Cases A and B.

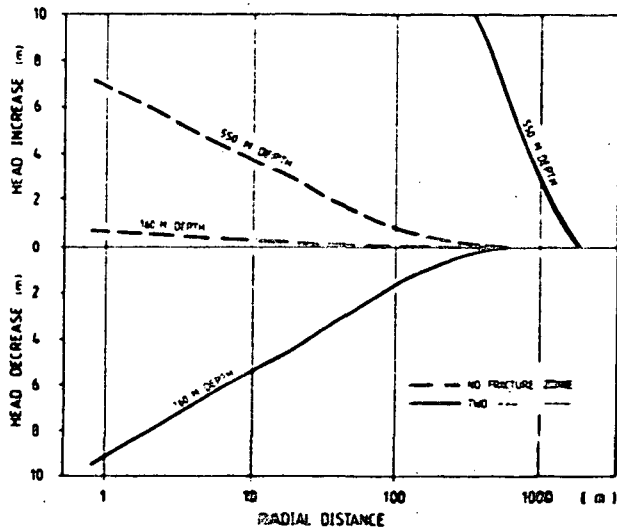

Figure 3.9: Groundwater influence due to the difference in piezometric head before and after drilling along a horizontal profile projecting from the borehole out into the bedrock (steady state). Cases C and D.

3.7 Drilling Debris

The debris formed during drilling consists of a very fine-grained powder. The grain size, which varies with rock-type, drill-bit shape and drill-bit-pressure, is 5-10 μm for granite (Craelius Co pers. commun. 1983). This corresponds to the finest interval of silt.

The bedrock volume converted into debris is 0.75 m^3 for a 700 m borehole of diameter 56 mm and a core diameter of 42 mm. Assuming a porosity of 70 % the drilling debris will occupy a volume of 2.5 m^3 . In general, below 100 m depth no flushing water, and thereby no drilling debris, is returned to the surface. Thus, 2.2 m^3 drilling debris will remain in the borehole and the adjacent bedrock after the drilling is completed. In comparison, a 700 m empty borehole of 56 mm diameter has a volume of 1.7 m^3 and the drilling debris would thus fill out a 900 m borehole.

Some of the drilling debris is removed by gas-lift pumping but to date only qualitative measurements have been performed at the Swedish site investigations (see Section 6). Some authors claim that gas-lift pumping does not remove the impairment (NUREG, 1983).

The drilling debris influences the hydraulic conditions in the bedrock by obstructing the groundwater flow in the fractures. The bedrock volume around the borehole is called the skin zone, which serves to reduce the hydraulic communication between the borehole and the rock-formation. By using a transient hydraulic test-procedure and long injection-times the skin-zone will not normally affect the hydraulic conductivity measurements, only the transient course (Andersson and Carlsson, 1980). This is true when the injection time is of a long enough duration so that the perturbation from the imposed hydraulic pressure exceeds the skin-zone (radius). According to Andersson and Carlsson (1981) the

radius of influence (r_e) of a hydraulic test can be estimated from the formula:

$$r_e = \left(\frac{135 \cdot K \cdot t}{S_s} \right)^{1/2} \quad (3-14)$$

where K = hydraulic conductivity (m/s)
 t = injection time (min)
 S_s = specific storage (1/m)

Thus, the influence radius is dependent on the hydraulic conductivity of the tested borehole section and injection time (Figure 3.10). The specific storage is a parameter describing the elasticity of the combined bedrock-fluid system. The lower the S_s value the more rigid is the system and thus the influence radius increases as the force (excess water pressure) is less absorbed by the elasticity of the system.

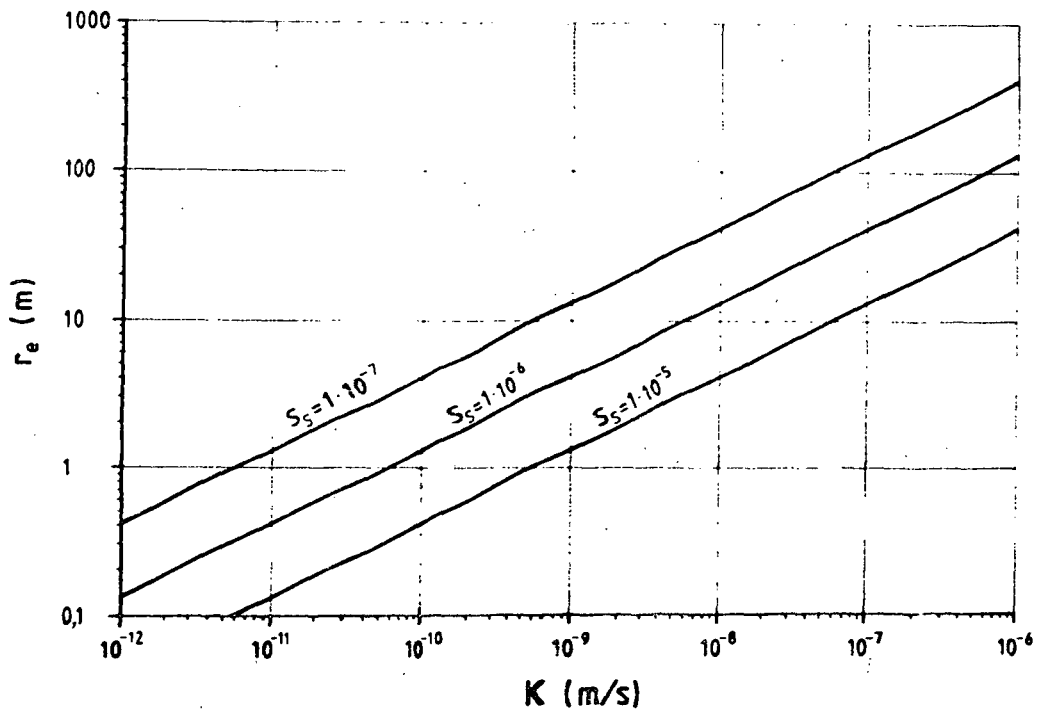

Fig 3.10: Theoretical relationship between influence radius and hydraulic conductivity for a homogeneous medium (injection time 120 min).

The skin-zone radius (r_s) formed by the drilling debris within the 700 m borehole (2.2 m^3) can be estimated if the porosity of the rock-formation directly affected by the drilling debris is known. The porosity of crystalline rock can, according to Norton and Knapp (1977), be divided into flow-, diffusion- and residual porosity:

$$\theta_{\text{tot}} = \theta_F + \theta_D + \theta_R \quad (3-15)$$

The flow porosity represents the voids within a rock through which the dominant mode of fluid and aqueous species transport is by fluid flow, and thus the potential volume for the drilling debris to be deposited. According to Norton and Knapp (1977), published and field observations indicate that flow porosities range from 1.10^{-3} to 1.10^{-6} . Furthermore, flow porosity is a small fraction of the total porosity. Gale (1982) points out that it is quite possible that the total fracture porosity is much higher than the flow fracture porosity computed from injection tests. In fact, it is reasonable to assume that the fractures have openings which are not participating in the flow, but rather provide voids for the contaminant of drilling debris. Values of the flow porosity in crystalline bedrock are presented in Table 3.5.

Table 3.5: Flow porosity determined from crystalline bedrock.

Rock type	Flow porosity	Reference
Granite (Stripa)	1.2×10^{-4}	Lundström and Stille (1978)
" "	8.0×10^{-5}	Andersson and Klockars (1984)
Granite	$5 \times 10^{-2} - 4 \times 10^{-5}$	Bianchi and Snow (1969)
Granite rock	1×10^{-4}	Gale (1982)
Quartz diorite	$2-3 \times 10^{-3}$	Villas (1975)

The skin-zone radius can be estimated using the following expression for a 700 m borehole at maximum flow porosity (i.e. 100 %).

$$r_s = \left(\frac{2.2}{700 \pi \theta_F} + r_b^2 \right)^{1/2} \quad (3-16)$$

where θ_F = flow porosity
 r_s = skin-zone radius (m)
 r_b = borehole radius (m)

In Figure 3.11 the estimated skin-zone radius versus different flow porosities is given at different degrees of filling. At a flow porosity of 1.10^{-3} the skin-zone radius changes from 1.4 m to 1.0 m when the filling degree of the drilling debris changes from 50 % to 100 %.

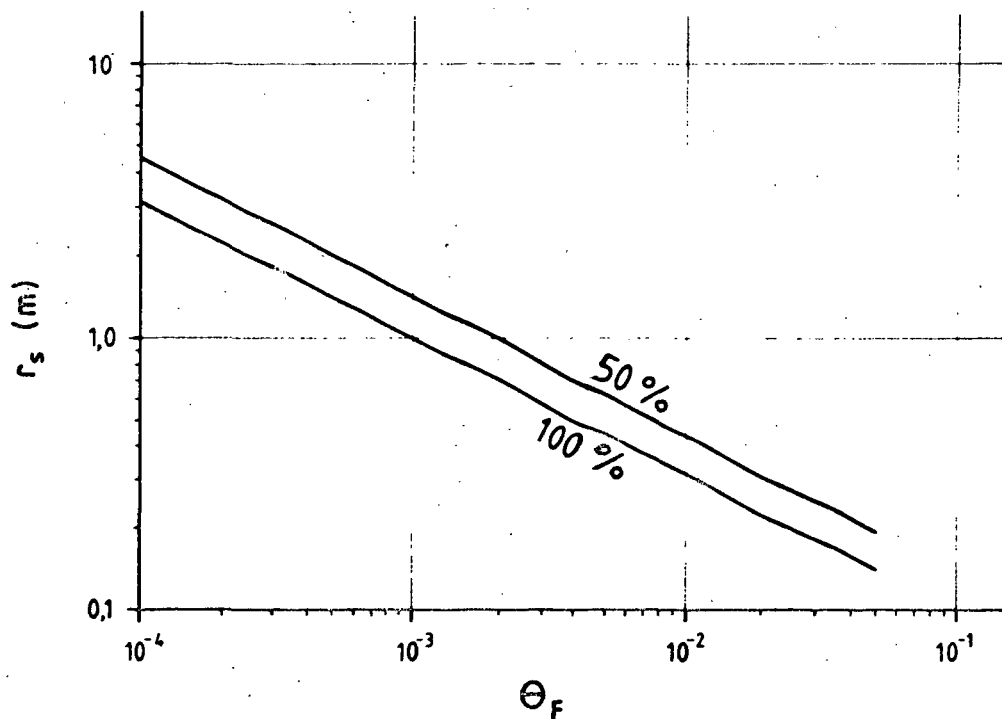

Figure 3.11: Estimated skin-zone radius (r_s) for different flow porosities (θ_F) at 100 % and 50 % outfilling with drilling debris from a 700 m deep borehole.

From Figure 3.10 it can be seen that with $r_s = 1$ m and with an injection time of 120 minutes, the hydraulic conductivity of the skin-zone must exceed $6 \cdot 10^{-11}$ m/s when $S_s = 1 \cdot 10^{-6}$ for the imposed perturbation to reach into the undisturbed rock formation.

For example, a skin-zone radius of $r_s = 1$ m along the whole borehole is of course a purely statistical measure. In reality the skin-zone is a function of the hydraulic conductivity, i.e. the higher the k -value of a borehole section the more drilling water will flow through it, and also the amount of drilling debris. Therefore, from the calculations in section 3.2 the amount of drilling water from the drilling procedure entering 25 m-sections of a borehole reflects the distribution of the width of the skin-zone radius.

Supposing the concentration of drilling debris in the flushing water is constant during drilling, then the amount of debris entering every 25 m-section is easily calculated. Furthermore, if the flow porosity and the amount of debris accumulation in the rock is estimated, the skin-zone radius of every 25 m-section can be roughly calculated. Two examples are presented in Figure 3.12.

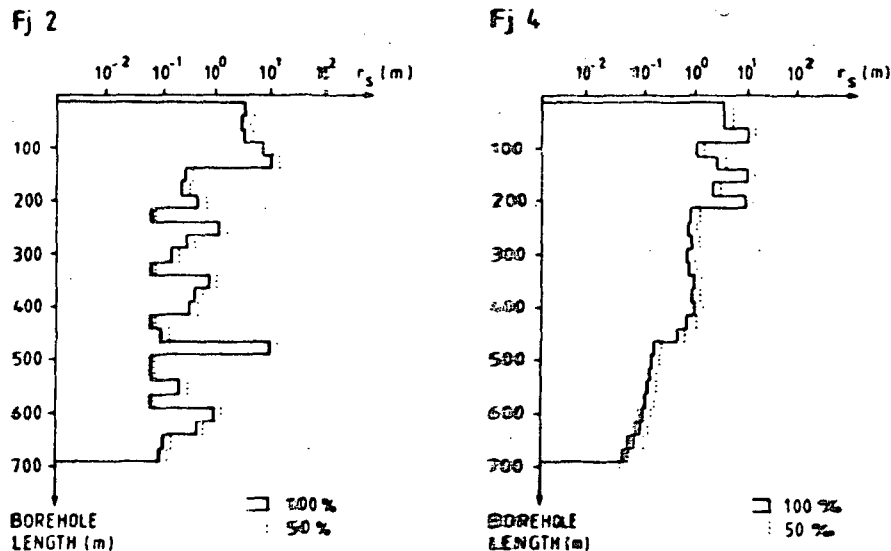

Figure 3.12: Rough calculations of the skin-zone radius in 25 m-sections of two 700 m cored boreholes assuming an accumulation degree of 50 % and 100 % of the flow porosity.

3.8 Summary

A borehole drilled in crystalline bedrock influences the groundwater conditions. In addition, borehole drilling, gas-lift pumping and hydraulic testing also influence the hydraulic and chemical conditions of the groundwater. The two main sources of influence found are those of drilling and the open-hole effect.

Based on values of drilling rate, drilling water pressure and flow-rate, and the hydraulic conductivity of the borehole, a very rough estimate can be made on the amount of water injected into the bedrock during drilling. It has been calculated that more than 100 m^3 of drilling water is injected to the bedrock under certain circumstances. The drilling water has a chemical composition normally diverging from the natural groundwater at each respective groundwater level traversed. During gas-lift pumping, only a small part (12-20 %) of the drilling water is flushed out; consequently most of it remains in the bedrock.

The long-term influence of the open-hole effect is illustrated by numerical modelling of a generic site. Depending on the occurrence of different hydraulic units such as fracture zones, and different assumptions as to the variation of hydraulic conductivity with depth, the amount of water circulating in a borehole might be several hundreds of m^3 per year.

During hydraulic testing additional water is injected into the bedrock, although this amount is very small compared to the amount injected during drilling. A second gas-lifting operation performed prior to water sampling flushes out some additional amounts (8-15 %) of the remaining drilling water. The final procedure to take place is water sampling, during which a somewhat smaller volume of water is removed from the borehole than during the cleaning operation. However, the major part of the injected drilling water is still left in the bedrock.

In Figure 3.13 the calculated amount of water entering and leaving the bedrock surrounding boreholes Fj2 and Fj4 (disregarding the open-hole effect) is presented. The figure also shows the water budget estimations for the sampled level 123 m (borehole length) in Fj2. In this case the long-term importance of the open-hole effect is illustrated.

The different terms of the water budget for a water sampled level (2.7 m length) is obtained by linear extrapolation (i.e. $\times 2.7/25$) of the calculated values from the actual 25 m section. This excludes the sampling amount, which is a direct measure of the 2.7 m section. This extrapolation is valid if the hydraulic properties (K-value, hydraulic head), measured in 25 m sections, are uniformly distributed along the complete section. If the water-conducting fractures are concentrated only within the sampled horizon, the influence of the borehole activities is correspondingly higher. If the sampled horizon falls outside a fracture zone, the opposite effect is true.

The numerical calculations presented also show that the fracture zones, i.e. zones of higher hydraulic conductivity, are of major importance. Short-circuiting by a borehole will eventually result in the drilling water being replaced by fresh groundwater. This replacement might be caused by the flow of drilling water from the rock to the borehole (recharge zone). In this case the fresh groundwater is likely to be from the hydraulic zone itself and thus representative for the level. When replacement is in the other direction (discharge zone), i.e. an inflow of water from the borehole to the rock, it is likely that the drilling water will be replaced by groundwater emanating from other parts of the rock than the actual zone. If the borehole is left for a long time, without the most conductive zones being sealed off by packers, the short-circuiting might seriously affect the naturally existing groundwater conditions at the site area.

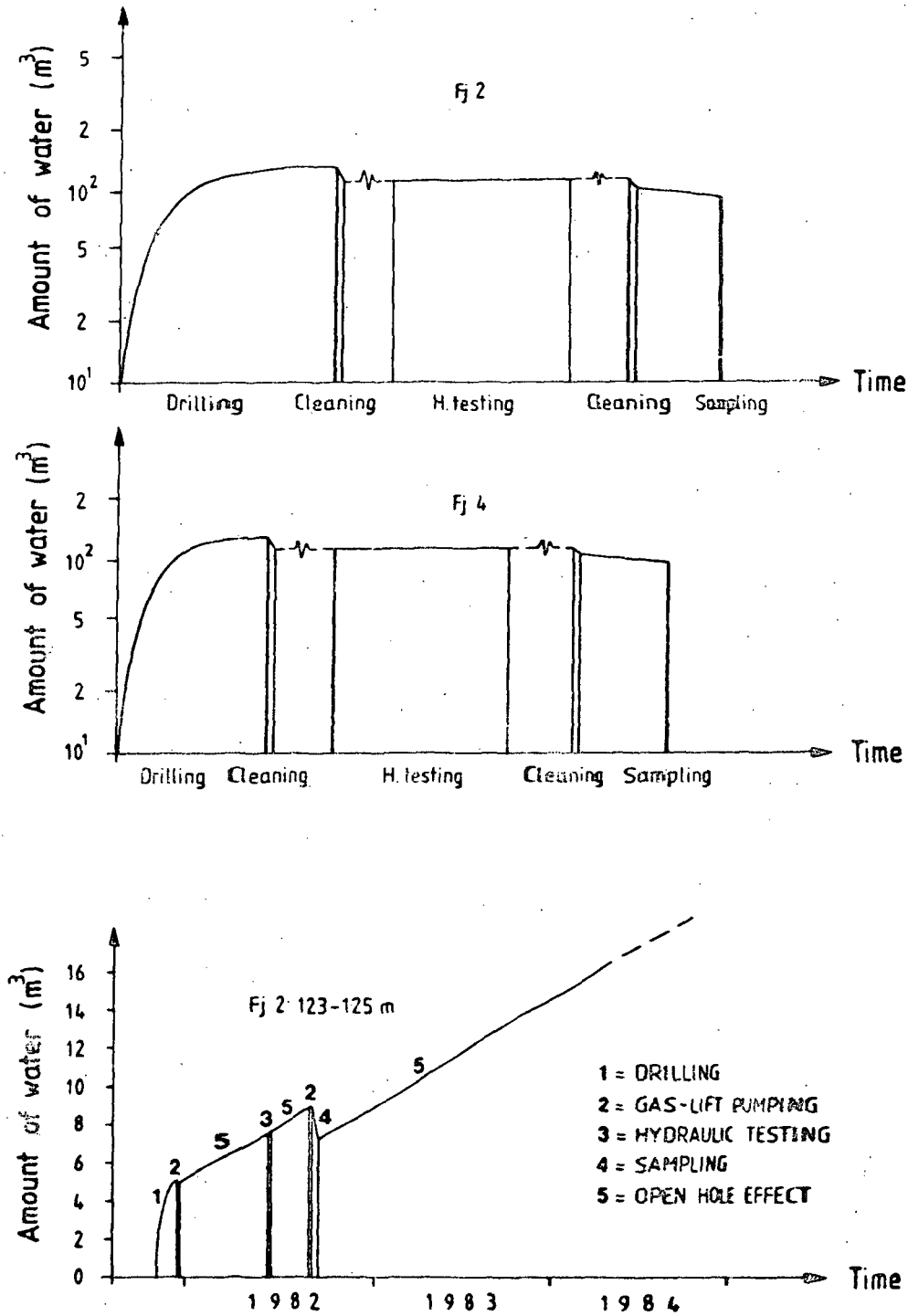

Figure 3.13: Estimated water budget during different activities for boreholes Fj2 and Fj4 disregarding the open-hole effect. The bottom diagram illustrates the water budget for section 123-126 m within borehole Fj2.

The time elapsed before sampling is conducted in the borehole will influence the quality of the sampled water. The kind of influence depends on whether the sampled section of the borehole represents a recharge or a discharge zone. If sampling is carried out in a recharge zone, all the drilling water once injected into the zone may have been replaced by fresh groundwater and thus the sample will consist of up to 100 % groundwater representative for the actual level. If, in contrast, sampling is carried out in a discharge zone, the water sample may be up to 100 % drilling water or fresh groundwater unrepresentative for the actual level. Consequently, depending on the hydraulic head, the hydraulic conductivity of the sampled zone, and on the time elapsed since completion of the core drilling, the sampled water may consist of anything between 100% drilling water and 100% fresh groundwater.

4. GROUNDWATER SAMPLING AND ANALYSIS

4.1 Sampling Procedures

Deep-hole groundwater sampling methods within the SKB programme are well established (e.g. Laurent, 1982; Almén et al 1983) and will thereby only be briefly outlined here.

In accordance with the hydraulic conductivity measurements several water-conducting zones are normally selected from each borehole. In general, zones recording positive heads combined with high hydraulic conductivities ($>1.10^{-9}$ m/s) have proved to be the most favourable for groundwater investigations. At lower conductivities, it is not possible to achieve the necessary pump flow of 100-250 ml/min for practical sampling purposes. Normally a 2.7 m section containing a single or multiple fissure zone is isolated using rubber packers inflated with nitrogen gas to a pressure of 0.8-1.0 MPa above the groundwater pressure.

Guided by the geological results from the core mapping, single fissures (if easily accessible) are preferred to the larger fracture zones because of the difficulty in ensuring complete isolation. If unsuccessful, water from outside the packer sleeves may be sucked into the sampling section by a short-circuiting fracture network which can channel water in from outside sources. In some cases samples are taken between one packer and the bottom of the borehole.

4.1.1 Equipment

The equipment used for the groundwater sampling is schematically shown in Figure 4.1. The water-bearing zone is sealed off with two rubber packers between which the sampling pump is positioned. Both the packers and the

pump are hydraulically operated from the ground surface. The water is transported up through a steel pipe the inside of which is coated with a polyethylene plastic lining. At the surface the water passes a "flow through" cell where the physico-chemical parameters pH, redox potential (Eh), sulphide content (pS^{2-}), dissolved oxygen content (DO) and conductivity are measured; pH, Eh and pS^{2-} are registered on a continuously monitoring chart recorder. The "flow through" cell is equipped with inlet and outlet valves for convenient calibration of the sensors. Calibration solutions are passed through the cell using a circulation pump. The cell and the downhole pump are made of stainless steel; all other parts that come in contact with the groundwater are made of plastic.

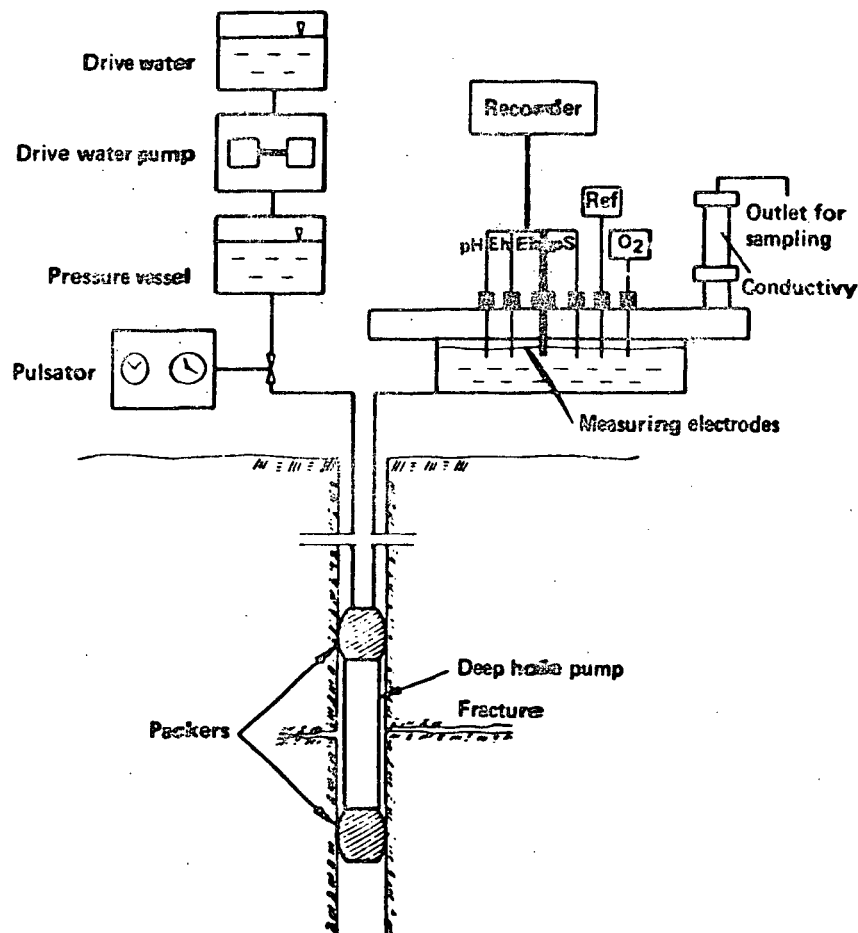

Figure 4.1: Schematic illustration of the sampling equipment.

4.1.2 Sampling programme

After drilling and on completion of the hydrologic tests, but prior to groundwater sampling, the borehole in question is normally cleared of residual waters (e.g. drilling water and groundwater mixtures from different sources) and rock debris. This is carried out by gas-lift pumping (see section 3.2) which involves introducing nitrogen gas down the borehole through a plastic hose. The borehole contents are then forced from the hole in a series of pulses of decreasing strength.

Sampling is usually carried out during a 14 day period for each horizon. For the first 4 days groundwater is continuously pumped to try and ensure maximum removal of drilling water or other contaminants that may still remain after gas-lift pumping. Neither sampling nor field-measurements are made during this stage. During the remaining 10 day period, systematic groundwater sampling (usually comprising 7 to 8 samples) and field measurements are carried out. The flow-rate chosen to pump the groundwater to the surface (100-200 ml/min) is based mainly on practical considerations, i.e. the groundwater yielding capacity of the fracture zone and the time required to collect the necessary volumes of water for adequate chemical characterisation of the groundwaters.

In some cases the sampling programme is prolonged by an additional two week period. After the sampling has been completed, the packers and equipment are moved to another suitable level or borehole. A schematic summary of activities surrounding the sampling period is presented in Table 4.1.

Table 4.1 Sampling activities within a normal week pumping period

Activity \ Day	1	2	3	4	5	6	7	8	9	10	11	12	13	14
Start up at a new section	x	x												
Calibration of field sensors		x					x							
Field measurements							(x)	x	x	(x)	x	x	x	x
Sampling for analysis of main constituents								x	x	x			x	x
Sampling for analysis of trace elements, isotopes and gases													x	
Pumping for cleaning			x	x	x	x								
Pumping for sampling							x	x	x	x	x	x	x	x

Table 4.2 Analysis performed on sampled groundwaters

Normal groundwater constituents	Trace elements, isotopes and dissolved gases
pH	Uranium and $^{234}\text{U}/^{238}\text{U}$
Conductivity	Radium
Sodium	Radon
Potassium	Thorium
Calcium	^2H (Deuterium)
Magnesium	^3H (Tritium)
Silicon	^{13}C
Ammonium	^{14}C
Iron	^{18}O
Manganese	Nitrogen, degassed
Carbonate, total	Helium, degassed
Chloride	Carbon dioxide, degassed
Fluoride	
Sulphate	
Sulphide	
Nitrate	
Nitrite	
Phosphate	
TOC (Total organic content)	
Iodide	

4.2 Sample Preparation and Analysis

The sampled groundwaters are analysed for a whole range of chemical species which are listed in Table 4.2. Most of the samples are collected in acid-washed polyethylene bottles and those for analysis of metals and cations are acidified with hydrochloric acid. For the analysis of total sulphide, the sample is collected in a glass bottle and preserved using zinc acetate and sodium hydroxide. Water for anion analysis is collected in a borosilicate glass bottle with a ground glass stopper. Care is taken to ensure that no air remains in the bottles after the stopper is in place; a leak-free seal is maintained by storing the bottle upside down. Particulate material is removed for analysis by filtration using a 0.45 micron membrane filter. During the period 1982 to the present several laboratories have been involved in the sample analysis. The most common methods used are atomic absorption and calorimetry.

Analysis of tritium and the stable isotopes (^2H and ^{18}O) are carried out on untreated water samples collected in glass bottles (1 litre and 300 ml amounts respectively). For ^{14}C analysis sufficient carbonate and carbon dioxide must be available from the groundwaters under investigation. If present, these contents have to be concentrated and care has to be employed to avoid any contamination by air or chemicals. Sample preparation is usually carried out in the field whereupon a nitrogenfilled polyethylene barrel (capacity 130 litres) is slowly filled with water which gradually displaces the nitrogen gas. Hydrochloric acid is added to convert the carbonate content to carbon dioxide and a stream of nitrogen gas removes the carbon dioxide which is passed and collected through a sodium hydroxide solution.

The analysis of uranium, thorium and the uranium daughter decay products (^{234}U , ^{226}Ra and ^{222}Rn) are carried out at two laboratories. Where uranium is

determined by delayed neutron activation (DNA), water samples for analysis are collected in a 100 ml glass bottle. From the same sample ^{226}Ra is determined by radiochemical separation and measurement of the alpha radiation; radon is determined by direct gamma spectrometry measurement, and thorium (^{232}Th) is determined by instrumental neutron activation (INAA). These results are normally reported in bequerel/litre (Bq/l) or microgrammes/litre ($\mu\text{g/l}$). At the second laboratory, the uranium content and uranium parent/daughter decay pair ^{238}U and ^{234}U are determined by high-resolution alpha spectrometry. For these measurements a five litre volume of water is collected and, in common for both analytical techniques, the samples are immediately filtered (0.45 micron membrane filter) and treated with sufficient hydrochloric acid to attain a pH of 1.0. Details of sample preparation for alpha spectrometry are outlined by Duniec et al (in preparation); uranium contents are expressed in $\mu\text{g/litre}$ and errors quoted are at the 2σ level.

Determination of dissolved uranium and its decay daughters using high-resolution alpha spectrometry was only introduced after investigations were completed for Gideå, Fjällveden and Svartboberget. Consequently, only some reserve samples were available for analysis. For the more recently investigated areas, i.e. Kamlunge, Taavinnunnen and Klipperås, this method has now become part of the hydrochemical programme.

5. RESULTS AND DISCUSSION FROM THE TEST-SITE INVESTIGATIONS

The results from the investigated test-sites are presented in Tables 5.2 to 5.25 and Figures 5.1 to 5.79. As discussed in Section 3.7, the hydrological data used for calculation purposes are based on hydraulic measurements carried out along 25 m sections of the boreholes (except for the total volume of water removed during the sampling period which is measured directly). The calculated hydraulic conductivity values for the 25 m sections are then linearly extrapolated to 2.7 m lengths. Usually there is a wide distribution of fracture type and frequency within such a 25 m section, and as only a small percentage of these fractures will be sampled for water (i.e. the 2.7 m section), the question arises as how representative are the hydrological data for the actual fracture or fracture zone being sampled ?

Linear extrapolation of the data to 2.7 m sections gives a true picture of the water budget if the hydraulic conductivity is uniformly spread along the 25 m length of borehole. However, in the event that the conductive horizon is contained solely within the 2.7 m section, the amount of contaminating water injected and removed due to drilling, hydraulic testing, open-hole effects and gaslift pumping, will be about one order of magnitude larger (i.e. max 25/2.7). This problem is partly resolved for those sampled sections where more detailed measurements (i.e. 5 or 10 m) have been performed. Furthermore, the selected levels for water sampling have in most cases high hydraulic conductivity, thus having a dominating influence on the piezometric head.

In addition, the amount of water removed by the gas-lift pumping is considered to be 100 percent of the drilling water. In practice, however, the drilling water is mixed with groundwater from different levels in the borehole so that the portion of drilling water may vary from 10 to 100 percent of the water which is removed by the gas-lift

Table 5.1 Probable compositional ranges of non-saline groundwaters in Swedish crystalline bedrock. The concentrations are given in mg/l. (Source: KBS-3).

pH	7 - 9	Ca ²⁺	10 - 40
Eh, V	0 - (-0.45)	Mg ²⁺	2 - 10
HCO ₃ ⁻	90 - 275	Na ⁺	10 - 100
SO ₄ ²⁻	0.5 - 15	K ⁺	1 - 5
HPO ₄ ²⁻	0.01 - 0.2	Fe ²⁺	0.02 - 5
NO ₃ ⁻	0.01 - 0.05	Mn ²⁺	0.1 - 0.5
F ⁻	0.5 - 4	SiH ₄ ⁺	0.05 - 0.2
Cl ⁻	4 - 15	SiO ₂ (tot)	3 - 14
HS ⁻	0 - 0.5	TOC	1 - 8

pumping. The amount of drilling water removed is then a factor of 0.1 to 1 times the amount of the total water removed.

Regarding the following presentation of the water chemistry, mention is made of non-saline groundwaters characteristic of crystalline bedrock environments in Sweden. For reference Table 5.1 presents the ranges of the most common chemical species from such groundwaters analysed within the SKB hydrochemical programme.

5.1 Fjällveden

The Fjällveden test-site is located in southern Sweden approx. 80 km south-west of Stockholm (Fig. 1). The region is characterised by a flat topography transected by several valleys following lineament trends mostly orientated in a north-westerly direction. The Fjällveden site is situated between two such valleys separated by a distance of 3 km.

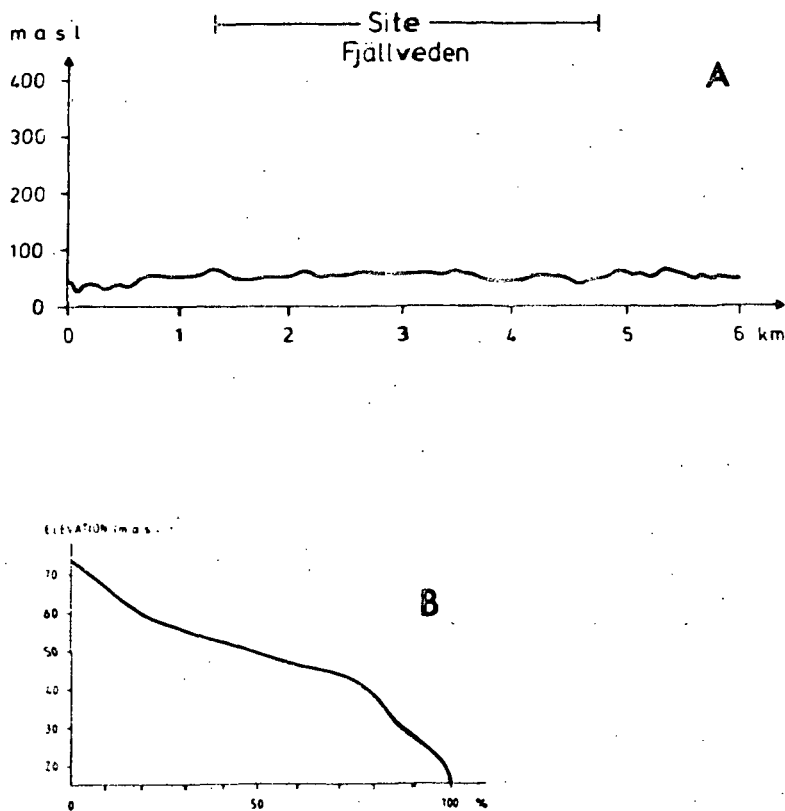

Figure 5.1 The Fjällveden test-site. A: Topographic profile across the site, B: Hypsographic curve showing altitude characteristics.

The differences of altitude in the area are small and the relief within the area is low. The highest and lowest points are 76 m and 38 m above sea-level respectively (Fig. 5.1).

The regional geology of the Fjällveden area has been previously described by Törnebohm (1882), Stålhös (1975), Lundström (1974; 1976) and Wikström (1978). As a result of SKB investigations carried out in the years 1981-1983, the detailed geology of the Fjällveden test-site area has been described by Carlsten et al (1983) and summarised by Ahlborn et al (1983b).

A map of the Fjällveden test-site area showing the general topographic features, together with the dominant rock-types and the main structural zones of weakness, is illustrated in Figure 5.2. The geology of the area is dominated by veined gneisses of sedimentary origin; subordinate masses of granite gneiss are also present and tend to be mostly concentrated along the northern margin of the area. The veined gneisses usually contain small amphibolite bodies orientated parallel to the structural foliation. Varying degrees of migmatisation have occurred coeval with the Svecokarelian orogeny (approx. 1800-2000 Ma) resulting in the formation of irregularly - shaped migmatite granitic bodies orientated parallel to the regional structural trend. Migmatitic gneiss is also present especially along the southern and eastern margins of the Fjällveden area.

As a result of some 49 shallow percussion boreholes (down to a maximum of 150 m) and 15 deep cored boreholes (to a vertical maximum of 700 m) the granite gneiss horizons are seen to be more continuous horizontally than vertically. This is thought to be the consequence of isoclinal folding of the granite and veined gneiss varieties along horizontal fold axes.

Pegmatite occurs throughout the study site in the form of dykes and minor massifs. The youngest rock type present is dolerite which occurs as vertical dykes (0.5 to 4.0 m wide) orientated in a north-westerly direction, i.e. perpendicular to the gneissic structures.

Structurally, the Fjällveden site is bounded to the north-east and south-west by old (approx. 1250 Ma) large-scale lineaments orientated in a north-westerly direction. Borehole investigations of these lineaments revealed that periodic movement had occurred resulting in shearing, crushing, brecciation and mylonitisation. Detailed investigations at the test-site itself have indicated the presence of 11 local fracture zones at depth, some of which are expressed at the bedrock surface

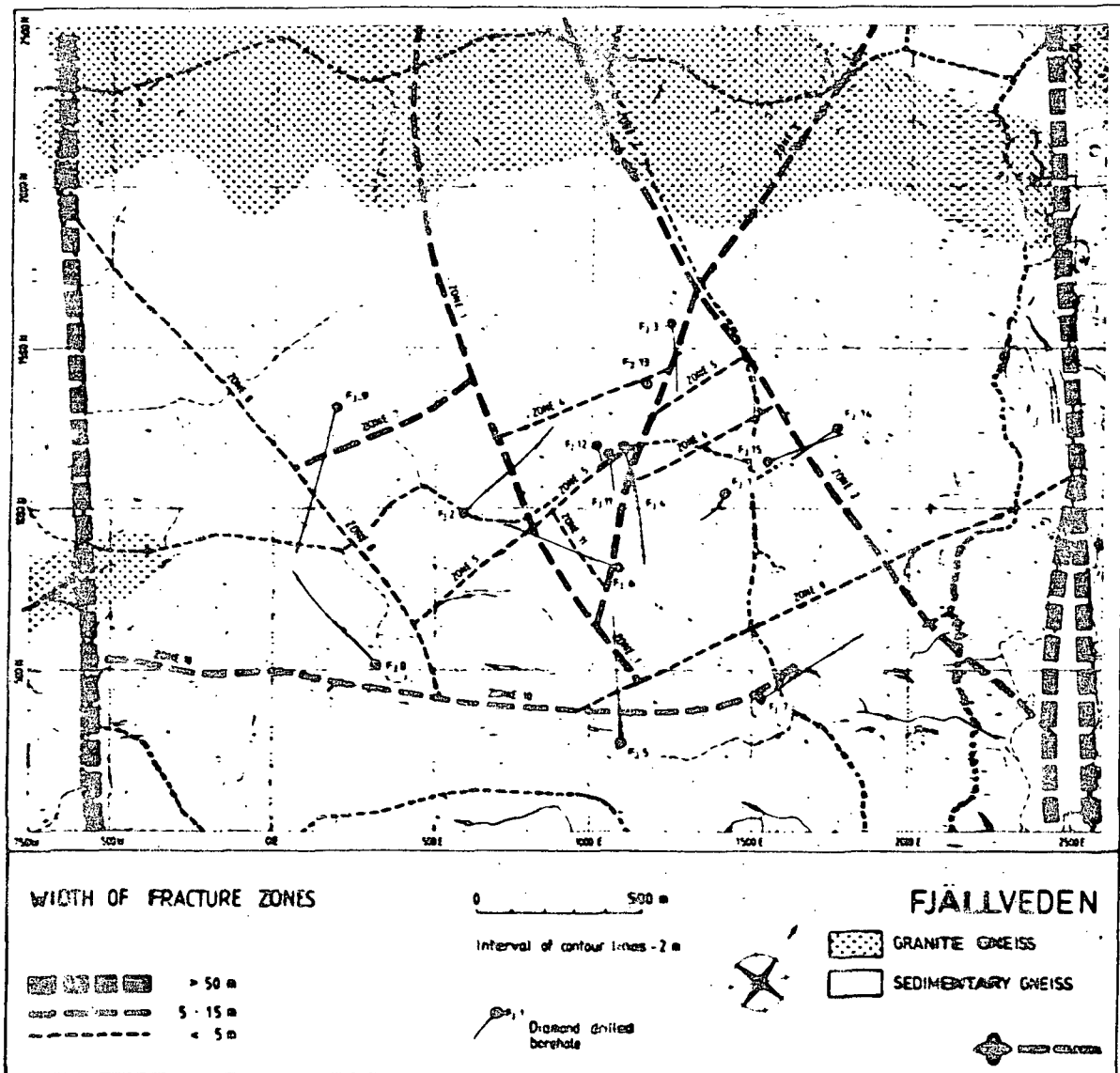

Figure 5.2 Topographic map of the Fjällveden test-site area showing the dominant rock types, the main structural zones of weakness, and the location of the 15 (Fj 1 to Fj 15) cored boreholes. (After Carlsten et al 1983).

as geophysical anomalies and/or topographic features. These regional and local fracture zones, which range in width from <5 to 15 m to >50 m respectively, and vary in dip from vertical to 70° , are illustrated in Figure 5.2.

Fracturing of the rock mass based on surface outcrop measurements has indicated two main directions: north-east and north-west, i.e. parallel with and perpendicular to the prevailing gneiss structures. The frequency of fractures longer than 0.5 m on outcrops is 0.9 fractures/m; at depth the total fracture frequency is 2.5 to 4.0 fractures/m down to 200 m, and then around 1.8 fractures/m down to 700 m. The high fracture frequency at depth is mainly due to horizontal release joints which have resulted from the removal of the ice overburden subsequent to the last ice epoch.

Taking individual rock types, the total fracture frequency for the various rocks irrespective of depth is lowest in migmatite (2.8 fractures/m) followed by granite gneiss (4.3 fractures/m) and finally amphibolite (5.9 fractures/m).

The hydrological features of the area have been described by Larsson (1983) and summarised by Ahlbom et al (1983a). The Fjällveden site is situated on the water divide between two regional drainage basins of 3620 km^2 and 340 km^2 respectively. This effectively means that the site constitutes a region of groundwater recharge, with the lower-lying parts representing local discharge areas for shallow groundwaters, which usually coincide with marsh or peat bog expanses.

The water balance in the Fjällveden area during the period 1951-1980 has been calculated to be:

Adjusted precipitation	650 ± 25 mm/year
Actual evaporation	450 ± 25 mm/year
Run-off	200 ± 10 mm year

Most of the run-off circulates in the near-surface soil horizons; only a minor fraction percolates into the bedrock.

Numerical modelling of the natural groundwater flow at Fjällveden shows a groundwater recharge rate in the crystalline bedrock of about 5 mm/year (Carlsson et al 1983). The main recharge period in this part of Sweden generally occurs in the Autumn whilst a secondary period occurs in the Spring when the accumulated snow cover melts resulting in the maximum groundwater levels of the year.

The groundwater temperatures at depths of 5-10 m show a very regular annual variation which reflects the annual mean air temperature (Knutsson and Fagerlind, 1977). For

Fjällveden this means an average groundwater temperature of about 7°C.

A general feature of the groundwater table profile in Sweden is that it reflects, on a much smoother pattern, the surface topography. At Fjällveden this means that the groundwater table is generally 1-3 m below the ground surface, but this depth increases to 10 m and more below minor hills and under slopes. Thus, the groundwater level at Fjällveden varies from 40 to 70 m above sea-level which indicates a relatively weak hydraulic gradient. The greatest gradient would appear to be along the slopes of the valleys which delineate the Fjällveden test-site.

5.1.1 Borehole Fj 2

Borehole Fj 2 was drilled at 60° to a vertical depth of 575 m (borehole length 700.76 m) in order to confirm the presence of fracture Zone 1 at depth (see Fig. 5.2). This was achieved between 340-360 m; in addition, three more minor zones were intercepted at 466 m, 596 m and between

598-599 m. Significant losses of drilling water occurred at levels 24 m, 87 m and 466 m.

The dominant rock type in the borehole is migmatite gneiss (90.6 length %) followed by gneiss granite (5.6 length %) and greenstone (3.7 length %); the migmatite extends down to a depth of about 500 m before being replaced by the gneiss granite. The number of fractures/metre recorded for each rock type was considered quite normal for the Fjällveden area, i.e. 2.4 for migmatite, 3.3 for gneiss granite and 5.2 for the greenstone. Related to depth, the fracture frequency (Fig. 5.3) was considered low and fairly uniform apart from the upper 150 m (stress-release fractures combined with a greater occurrence of greenstone), at 350 m (local fracture horizon Zone 1), and between 600-700 m (predominantly granite gneiss which is more susceptible to fracturing than the more plastically deformed migmatite).

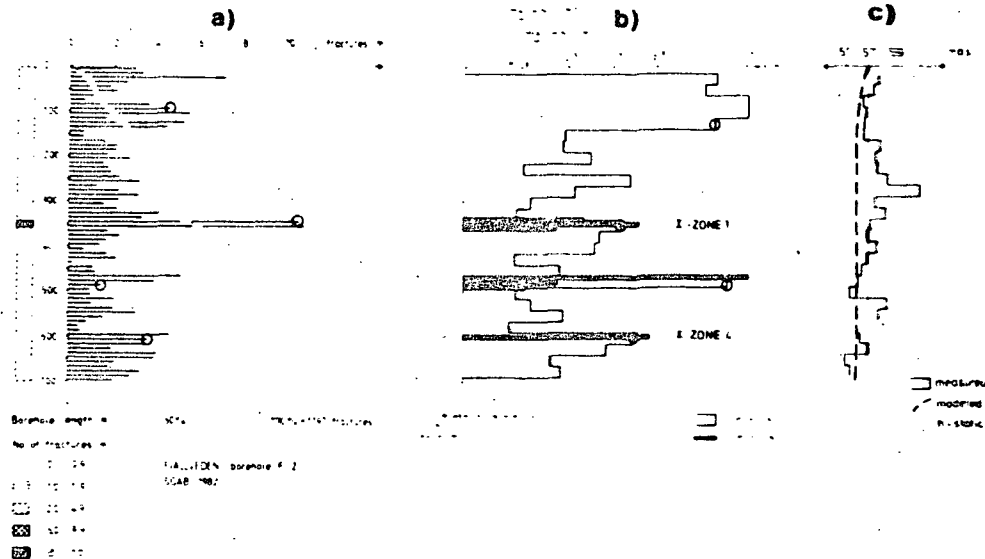

Figure 5.3 Hydrogeological characteristics of borehole Fj 2.
 a) Fracture frequency (for 10 m sections) and the cumulative percentage of fractures
 b) Hydraulic conductivity
 c) Piezometric head distributions and hydrostatic head in the borehole

Fj 2

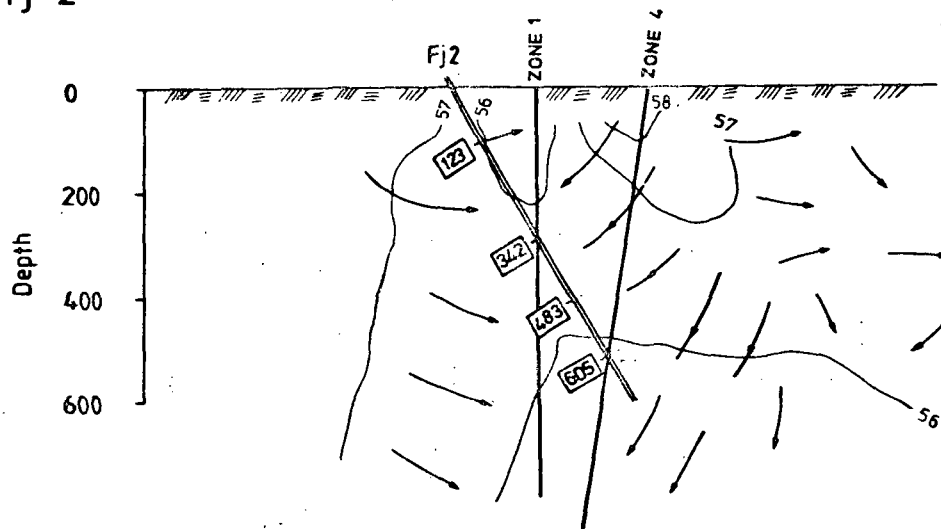

Figure 5.4 The groundwater flow-pattern and isopotentials in the vicinity of borehole Fj 2 illustrated by a vertical section in the sample plane as the direction of the borehole (modified after the numerical modelling of the Kemakta Consulting Co).

The groundwater flow-pattern in the vicinity of borehole Fj 2 is illustrated by a vertical section in the same plane as the direction of the borehole (Fig. 5.4). The flow-pattern is derived from the numerical modelling of the groundwater flow at the Fjällveden site (Carlsson et al 1983). The pattern shows that the groundwater flow component in the drawn section is directed towards the fracture Zone 1 (Fig. 5.4). In a three-dimensional respect, the flow direction is along Zone 1 towards the northwest (Fig. 5.2). The hydraulic gradients are small and the piezometric head along the borehole decreases rapidly from 57.0 m above sea-level in the uppermost part of the bedrock to 56.0 m at about 150 m along the borehole length, and is almost constant throughout the rest of the borehole (Fig. 5.3).

The natural piezometric head in the borehole, derived from Horner-plots of the hydraulic tests (Ahibom et al, 1983b), results in a more detailed picture than can be achieved from the numerical calculations. As the borehole intersects and short-circuits all the water-conducting sections, an open-hole water circulation occurs. Initially, the groundwater level in the borehole will adjust to the integrated pressure of all the borehole sections, i.e. the hydraulic heads. This is represented by the vertical line illustrated in Figure 5.3.c. Following this, all sections of greater head than the hydrostatic head of the borehole will tend to contribute water to the borehole, and contrastingly sections of lower hydraulic head will receive water. These sections of lower head can therefore receive water which originates either higher up or deeper down in the borehole, and the water mixture entering the section will mainly depend on the hydraulic head and hydraulic conductivity of the contributing sections. A qualitative estimate of flow direction for the circulating water in the borehole, together with the calculated water budget resulting from the various borehole activities, is compiled in Table 5.2.

5.1.1.1 Level 123 - 125 m (approx. 106 m)

The sampled section is located within dark-grey migmatite and is characterised by three distinct fracture zones in the core varying in width from 20 to 40 cms (5-10 fractures are characteristic of each zone), and more minor single fractures. These fractures intersect the axis of the core at angles ranging from 20° to 90° , and infilling mineral phases include calcite, chlorite, epidote and pyrite.

Table 5.2a: Measured hydraulic parameters and calculated water budget values of the various influences due to borehole activities at the water sampled levels in borehole P1-11.

Level	k-value* (m/s)	Head deviation* (m)	Flow direction (borehole trends)	Infiltrating water (+) (m ³)	Gas-lift pumping(-) (m ³)	Hydraulic nesting (+) (m ³)	Open hole effect before sampling(+) (m ³)	Sampled water before analysis(-) (m ³)
113-115	2.0 x 10 ⁻⁷	+0.35	+	1.11	0.11	1.00	0.91	1.7
116-118	1.0 x 10 ⁻⁷	+0.11	+	0.11	0.002	0.001	-1.01	3.9
119-121	3.0 x 10 ⁻⁷	+0.13	+	0.13	0.007	0.004	0.08	5.3
122-124	3.0 x 10 ⁻⁷	+0.13	+	0.13	0.004	0.001	0.08	4.8

* 25 m section; head deviation from hydrostatic head in the borehole (in metres of water).

Table 5.2b: Some geochemical parameters of groundwater sampled from the 25 m section in borehole P1-11.

Level	Depth below surface (metres)	Temperature (°C)	pH	Ca ²⁺ (mg/l)	Mg ²⁺ (mg/l)	Na ⁺ (mg/l)	K ⁺ (mg/l)	Cl ⁻ (mg/l)	SO ₄ ²⁻ (mg/l)	NO ₃ ⁻ (mg/l)	NO ₂ ⁻ (mg/l)	CO ₃ ²⁻ (mg/l)	HCO ₃ ⁻ (mg/l)	SiO ₂ (mg/l)	Fe (mg/l)	Mn (mg/l)	Zn (mg/l)	Cu (mg/l)	As (mg/l)	Activity ratio
P1-11	113-115	11.5	7.5	120	40	10	5	10	10	10	10	10	10	10	10	10	10	10	10	10
P1-11	116-118	11.5	7.5	120	40	10	5	10	10	10	10	10	10	10	10	10	10	10	10	10
P1-11	119-121	11.5	7.5	120	40	10	5	10	10	10	10	10	10	10	10	10	10	10	10	10
P1-11	122-124	11.5	7.5	120	40	10	5	10	10	10	10	10	10	10	10	10	10	10	10	10

Note: These analyses represent samples taken towards the end of each sampling period; the pH and temperature should therefore be the most representative for the composition of the water in the borehole.

1. Total dissolved solids (TDS) is the number of tribits atoms per 10⁶ oxygen atoms.

2. Arbitrary values.

3. Values considered statistically representative.

Hydrology

The sampled level lies within a 25 m section of high hydraulic conductivity ($K = 2.10^{-7}$ m/s). This is perhaps not so surprising as this level is located at the bottom margin of that portion of bedrock which is commonly more highly fractured, and correspondingly characterised by relatively conductive conditions. The calculated water budget of the sampled level is presented in Table 5.2a. The results show that a considerable amount of contaminating water (i.e. drilling water; injection test water) has been introduced into this level (i.e. positive values) and that a significant amount still remains after gas-lift pumping and pumping prior to sampling (i.e. negative values) (Fig. 5.5). These

Handwritten note: The water budget is calculated as the difference between the total inflow and the total outflow.

Handwritten note: The water budget is calculated as the difference between the total inflow and the total outflow.

calculations also show, based on the presence of a negative deviation in hydraulic head from the hydrostatic pressure, that whilst the borehole was open (i.e. prior to the second gas-lift pumping and sampling), there was a tendency for water to flow from the hole into the bedrock along the conducting horizon, resulting in additional contamination.

Water geochemistry

The sampled water (Table 5.2b) is characterised by a pH of 8.0; of the major cations, Na^+ and Ca^{2+} are all present in appreciable but normal amounts for non-saline groundwater in Swedish crystalline rocks; likewise for the major anions HCO_3^- and Cl^- (see Table 5.1). The presence of 2% I^- (i.e. tracer) suggests some limited mixing with the drilling waters.

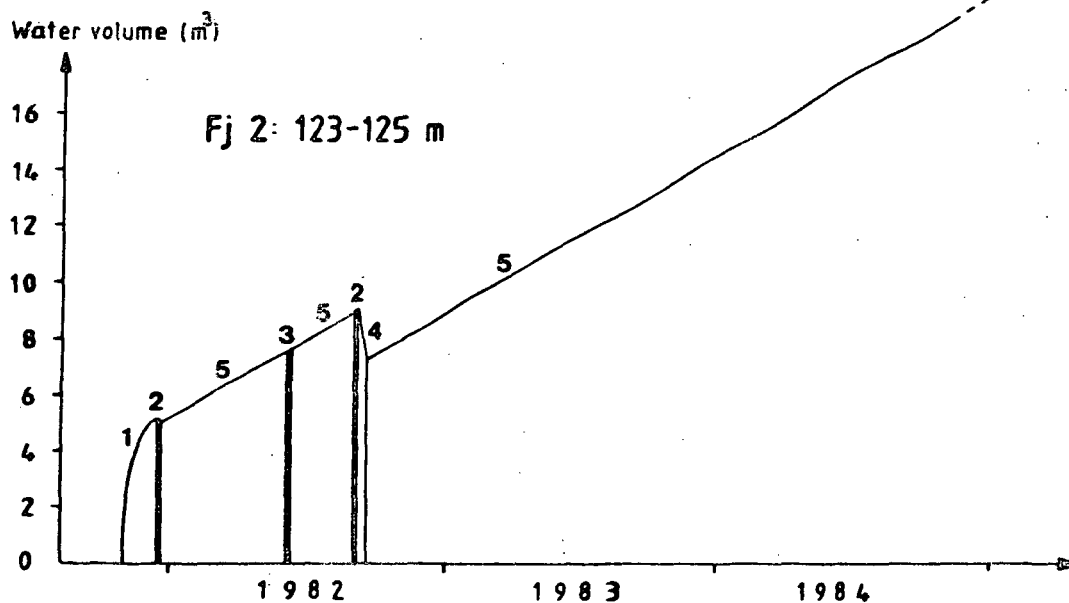

Figure 5.5: Schematic illustration of the calculated water budget for level 123-125 m in borehole Fj 2 (Fjällveden). 1 = Drilling water; 2 = Gas-lift pumping; 3 = Hydraulic testing; 4 = Sampling; 5 = Open-hole effect.

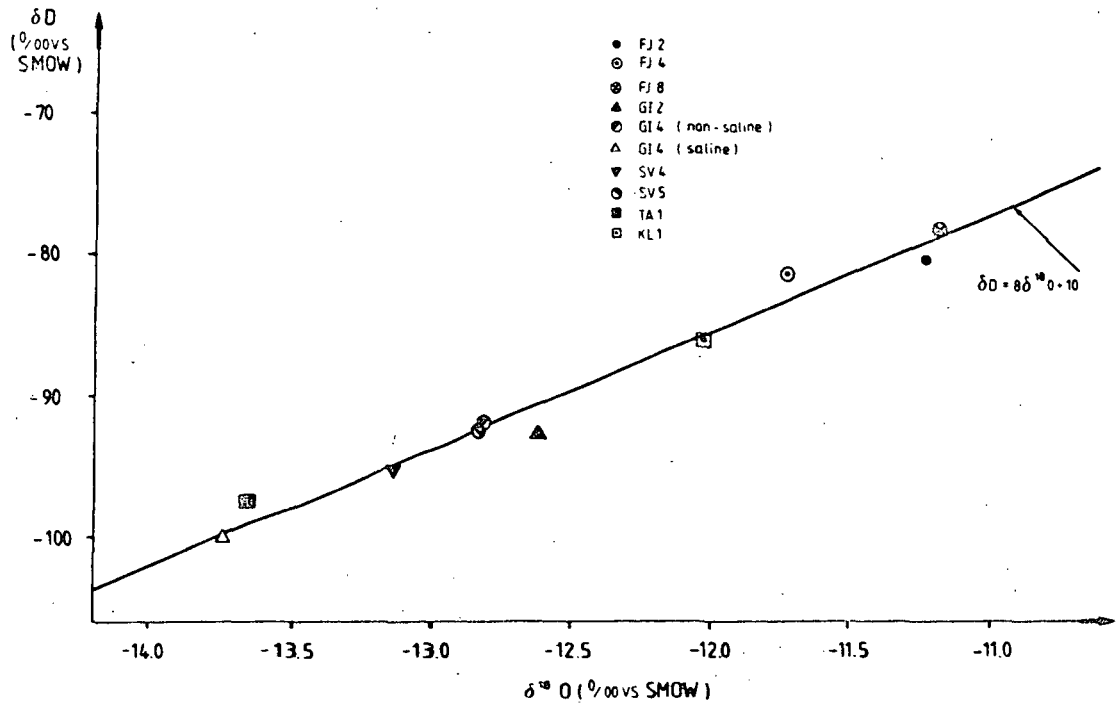

Figure 5.6: $\delta^{18}O$ and deuterium compositions of borehole groundwaters from the SKB test-site areas.

Redox-sensitive parameters

The presence of S(-II) and Fe(II) indicate a reducing environment. This is in part supported by an Eh value of -80 mV although partly off-set by the presence of small, but significant amounts of oxygen (0.05 mg/l).

Isotope geochemistry

The level is characterised by $\delta^{18}O$ and δ^2H values (-11.24 ppt and -80.5 ppt respectively) representative of a meteoric water source (Fig. 5.6). The ^{14}C data indicate an age of some 4725 years; no tritium analysis is available.

Uranium geochemistry

A uranium content of 0.55 ppb is indicated by DNA; no further data of uranium, or the $^{234}\text{U}/^{238}\text{U}$ activity ratio, are available.

Summary

The results show that the sampled horizon is characterised by waters which represent:

- residual water from drilling activities and hydraulic testing
- water from nearby sources (at higher or lower levels) whilst the borehole was open; penetration into the bedrock was facilitated by a negative piezometric head and a high K-value.

Such contaminating waters were not completely removed during gas-lift pumping or pumping prior to sampling. Thus the waters sampled for analysis represent a significant fraction initially derived from other sources. Chemically (Table 5.2b), such contamination is most readily seen as low, but significant amounts of the drilling water tracer (I^-); the remaining chemical parameters appear to be relatively insensitive. Isotopically, particularly in the absence of tritium analysis; it is difficult to assess any marked effect although some "dilution" of the ^{14}C age might be expected.

No significant variation in the physico-chemical parameters of the waters during the period of sampling was observed (Laurent, 1983a).

5.1.1.2 Level 342 - 344 m (approx. 293 m)

The dominant rock type is dark-grey migmatite; a greenstone horizon occurs at about 350 m depth. The sampled borehole section is characterised by a high fracture frequency (i.e. approx. 12 fractures/metre) which comprises part of fracture Zone 1 (Fig. 5.2), defined from 340 - 354 m along the borehole. The fractures intersect the axis of the core at angles varying from 30° - 80° , and the infilling mineral phases mostly include pyrite and chlorite.

Hydrology

The hydraulic conductivity measured along a 25 m section was recorded as $1.6 \cdot 10^{-9}$ m/s, and the piezometric head was found to exceed the hydrostatic borehole pressure by 0.2 m. The calculated water budget presented in Figure 5.7 and Table 5.2 show that the different influence effects should be minimal and that contaminating waters should be removed soon after the commencement of water sampling.

In this part of the borehole detailed water injection tests have been carried out and measurements from a 10 m section, which includes the 2.7 m section, yielded a K-value of $2 \cdot 10^{-10}$ m/s and a negative head deviation of -1.2 m. Thus the open-hole effects would tend to be contrary to those indicated from the calculations. However, as the overall influence effects are small, the water budget is not expected to change from negative to positive during sampling.

Short-time injection tests (15 minutes duration) along 2 m sections have also been carried out resulting in a K-value of $5 \cdot 10^{-10}$ m/s.

Water geochemistry

The sampled water has a pH of 7.3; of the major cations, Na^+ and Ca^{2+} are all present in appreciable amounts for non-saline waters, likewise for the major anions HCO_3^- and Cl^- . The presence of 8.7 % I^- , which is considerably higher than the previous level, indicates a significant increase in mixing with drilling waters.

Redox-sensitive parameters

The presence of S(-II) and Fe(II) suggest an environment which is still largely reducing. This is further supported by an Eh value of -40 mV although the amount of dissolved oxygen is high (0.2 mg/l).

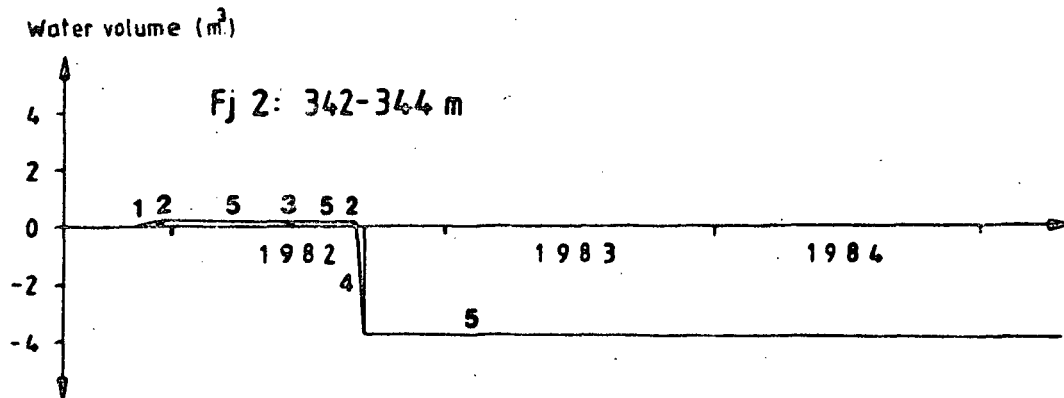

Figure 5.7: Schematic illustration of the calculated water budget for level 342-344 m in borehole Fj 2 (Fjällveden). 1 = Drilling water; 2 = Gas-lift pumping; 3 = Hydraulic testing; 4 = Sampling; 5 = Open-hole effect.

Isotope geochemistry

The $\delta^{18}\text{O}$ value of -11.31 ppt (no $\delta^2\text{H}$ analysis is available) supports a meteoric water source. The ^{14}C indicates an age of some 10960 years; contrastingly the tritium content (19 TU) suggests a significant mixing with younger, near-surface water.

Uranium geochemistry

A uranium content of 0.24 ppb was obtained by DNA; no additional data of uranium, or the $^{234}\text{U}/^{238}\text{U}$ activity ratio, are available.

Summary

The results show that the sampled horizon is characterised by waters which represent:

- residual water from drilling activities and hydraulic testing.
- minimal mixing of open-hole waters along the conducting fracture zone because of the low hydraulic conductivity.
- the waters are characterised by a significant older component (from ^{14}C dating), although this is not reflected by the tritium value or the other chemical species which are more typical of near-surface water or shallow groundwaters.

Drilling water contamination is seen as a high iodine content (8.7 %) and may also have contributed to the component of younger water present, as indicated by the tritium content and the anomalously high Fe (II) content. The iron may be partly explained by the reaction of younger borehole water with the steel piping leading up from the isolated section. The significant amount of

dissolved oxygen in the water may also reflect a younger, near-surface water component.

No significant variation in the physico-chemical parameters of the water during the sampling period was observed.

5.1.1.3 Level 483 - 485 m (approx. 409 m)

This section represents an unfractured portion of fresh dark-grey migmatite; the nearest recorded fracture zones along the core are located some 2 m on either side of the sampled section.

Hydrology

The measured hydraulic conductivity along the 25 m section ($K = 3.9 \cdot 10^{-7}$ m/s) is extremely high for the actual depth; the section is also characterised by a negative piezometric head (Table 5.2). The result is that the water budget is greatly influenced, primarily from open-hole effects (Fig. 5.8).

In this part of the borehole hydraulic tests have been carried out along 2 m and 10 m sections. These results are similar and show how unevenly distributed the hydraulic conductivity is along the section. In point of fact, the hydraulic conductivity in the sampled section is even lower than the measuring limit of the equipment, showing that the water budget presented in Table 5.2 is not representative for this horizon.

Water geochemistry

The pH of the sampled water is 7.4; in common with the upper two levels, the contents of Na^+ , Ca^{2+} , HCO_3^- and Cl^- are normal and representative for non-saline waters. The presence of 7.9 % I^- is still high and suggests a significant drilling water component.

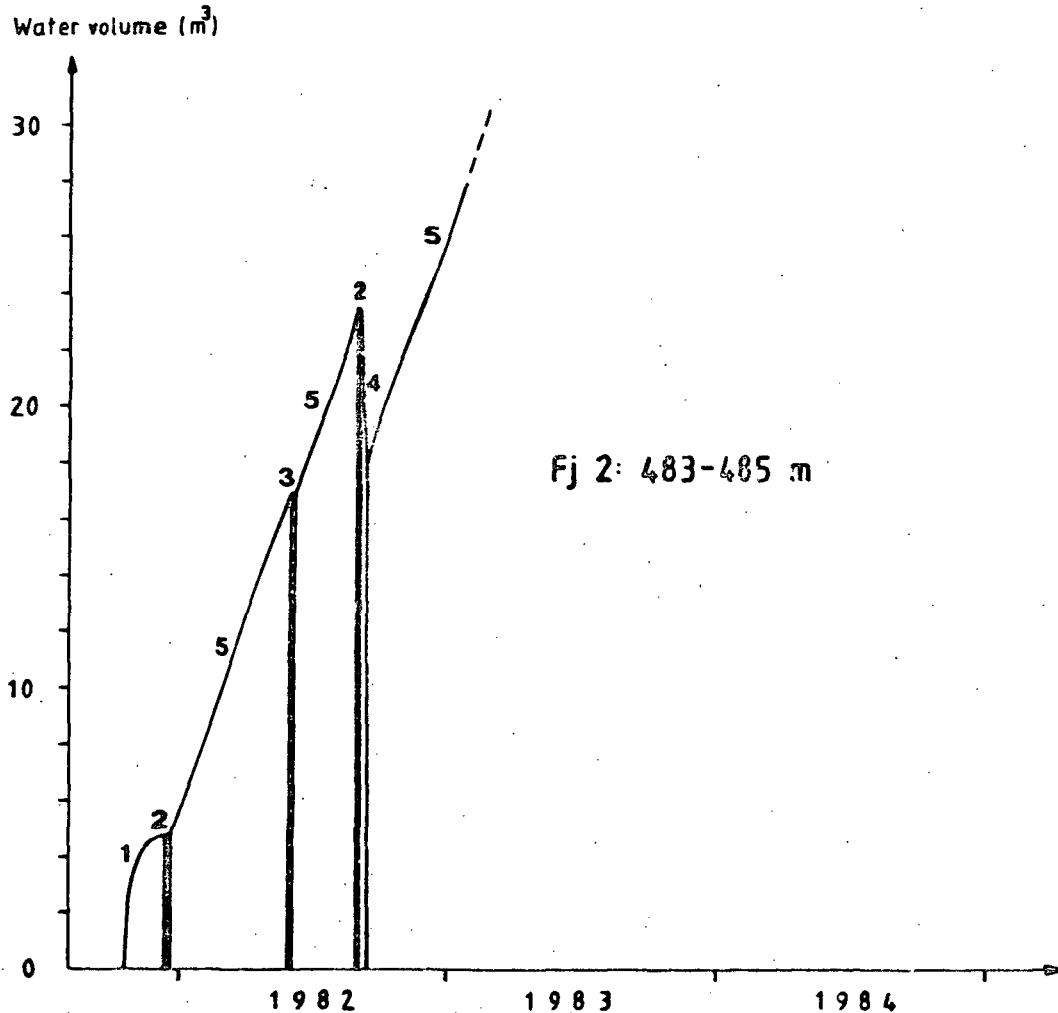

Figure 5.8: Schematic illustration of the calculated water budget for level 483-485 m in borehole Fj 2 (Fjällveden). 1 = Drilling water; 2 = Gas-lift pumping; 3 = Hydraulic testing; 4 = Sampling; 5 = Open-hole effect.

Redox-sensitive parameters

The presence of S(-II) and Fe(II) indicate a reducing environment. This is in part supported by an Eh value of -110 mV although partly off-set by the presence of small but significant amounts of dissolved oxygen (0.05 mg/l).

Isotope geochemistry

The $\delta^{18}\text{O}$ value of -11.35 ppt (no $\delta^2\text{H}$ analysis is available) supports a meteoric origin to the water. The ^{14}C age determination of 4235 years is similar to the shallowest sampled level, but considerably lower than the intermediate level described. This, together with the high tritium value of 19 TU, would suggest a significantly high component of young, near-surface water.

Uranium geochemistry

Uranium contents vary (depending on the analytical method) from <0.1 to 0.12 ppb; the $^{234}\text{U}/^{238}\text{U}$ activity ratio of 2.1 indicates that the waters at this level are not at isotopic equilibrium.

Summary

The results show that the sampled level is characterised by waters which represent:

- residual water from drilling activities and hydraulic testing.
- mixed water sources from the borehole.

Water budget estimations from 2 m and 10 m sections suggest that the contaminating water was minimal and was quickly removed during the sampling period. However, the

chemical analyses (Table 5.2b) show that a significantly high component of young shallow groundwater is present in the sampled waters, together with residual drilling water. This former component was probably pumped into the sampled section from above the borehole; this is further indicated by the high Fe (II) content which, as in the previous level, was probably the result of reactions between borehole water and the steel piping above the packer system.

No significant variation in the physico-chemical parameters of waters during sampling was observed.

5.1.1.4 Level 605 - 607 m (approx. 506 m)

The sampled section represents the dark-grey migmatite which contains several single fractures (approx. 5 mm wide) orientated at 30° - 50° to the borehole axis. The most common infilling constituent is chlorite, followed by pyrite, calcite and biotite. This fractured portion is located just below the intersection of the borehole with local fracture Zone 4 (approx. 598 m).

Hydrology

The high hydraulic conductivity value obtained ($K = 3.0 \cdot 10^{-9}$ m/s) is readily explained by the presence of fracture Zone 4. In fact the 10 m section measured (which included Zone 4) corresponded to the total transmissivity of the 25 m section (i.e. the water injected during the 25 m test flowed mainly into the bedrock within the 10 m section). Ironically the 2 m section injection tests showed that the hydraulic conductivity along the sampled section was below the measuring limit. As a result, the water budget calculation illustrated in Figure 5.9 reveals some small effects from the borehole activities which, however, are not applicable to the sampled zone.

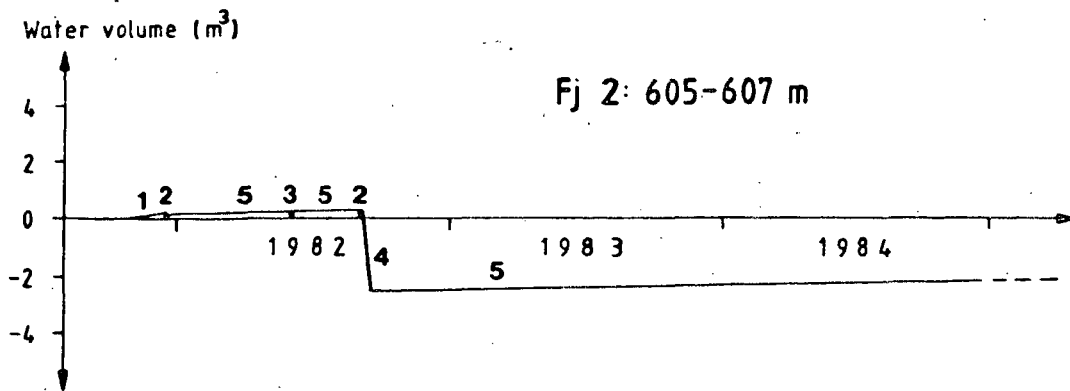

Figure 5.9: Schematic illustration of the calculated water budget for level 605-607 m in borehole Fj 2 (Fjällveden). 1 = Drilling water; 2 = Gas-lift pumping; 3 = Hydraulic testing; 4 = Sampling; 5 = Open-hole effect.

Water geochemistry

In contrast to the above three levels, the representative water sampled here exhibits a high pH (8.9) and contains greater amounts of Na^+ and Cl^- but lesser amounts of Ca^{2+} and HCO_3^- ; the more saline character of the water is also reflected by the high conductivity value. The relatively high I^- content (3.9 %) may be partly a function of drilling water mixing or naturally high contents in the more saline water.

Redox-sensitive parameters

The presence of only small amounts of S(-II) and Fe(II), and an Eh value of -20 mV (the highest of all four measured levels) indicates that this groundwater is only marginally reducing. This is further supported by the highest dissolved oxygen content (0.30 mg/l) encountered within the borehole.

C-068

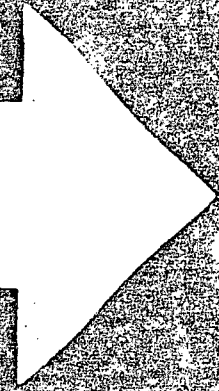

86.06.13

AD.87.11

11.5.5+10

Isotope geochemistry

The $\delta^{18}\text{O}$ value of -14.11 ppt (no analysis of $\delta^2\text{H}$ is available) is lower than for the other levels which further emphasises the difference in character of this water, although a meteoric origin is still assumed. The depth/ age relationship is supported by a value of 13920 years by the ^{14}C method; minimal mixing by younger waters is indicated by the near-absence of tritium (< 3 TU).

Uranium geochemistry

One analysis is available indicating a very low dissolved uranium content of < 0.2 ppb.

Summary

The results show that the water sampled from this level differs in most respects from the three higher levels; the waters thus represent:

- minimal presence of residual water from borehole activities (aided by a very low hydraulic conductivity).
- no mixing with younger, near-surface or shallow groundwater types.
- an old saline groundwater.

During the period of sampling there was a tendency for the waters to become increasingly more saline, i.e. an increase in Cl^- from 140-170 mg/l and a decrease of HCO_3^- from 97-81 mg/l; a gradual increase in pH from 8.6-8.9 was also observed. These trends probably represent the initial removal of some residual contaminating water before the water composition became stabilised and representative.

5.1.1.5 Borehole summary and discussion

Geological mapping, and hydrological investigations along 25 m sections (in some cases more detailed measurements have been carried out along 10 m and 2 m sections) in the borehole, have resulted in locating four conducting levels considered suitable for the chemical characterisation of the groundwaters. Two of these levels (342-344 m and 605-607 m) represent the intersection with the borehole of local fracture Zones 1 and 4 respectively, which are thought to extend to the bedrock surface.

The natural groundwater flow in the near-vicinity of the borehole is downwards, particularly towards Zone 1. At the borehole intersection with Zone 1, a positive piezometric head exists. This contrasts with the other three levels which show negative values along the measured 25 m sections. In general, the water budget calculations suggest that at only two levels (i.e. those characterised by Zones 1 and 4) should truly representative water be sampled, i.e. devoid of residual water from borehole activities or water mixtures from other sources within the bedrock. However, only at levels 123-125 m and 342-344 m is it thought that the water budget values (i.e. based on 25 m sections) are directly applicable to the 2.7 m borehole lengths actually sampled. Thus, from the hydrological point of view the only representative water sample would be from level 342-344 m.

The overall chemical results indicate that at only the deepest level is the water truly representative and therefore uncontaminated by borehole activities and/or mixing with other waters originating from different sources. As indicated by non-detectable amounts of tritium (< 3 TU), no component of young surface or near-surface water is present. As the water is saline in type, the presence of $3.9\% \text{ I}^-$ may be explained by natural background values rather than due to drilling

water contamination. Finally, the high ^{14}C age of 13920 years and a very low dissolved uranium content (< 0.20 ppb) are further indications that this water is a true deep groundwater of reducing character. Hydrologically, this could only be explained if the fractures contained within the sampled section are in some way connected with Zone 4 (located 4.5 m above the sampled section), or if water from Zone 4 has been sampled via the borehole. Zone 4 has an estimated K-value of 7.10^{-9} m/s.

The water associated with the local fracture Zone 1 (section 342-344 m) is also characterised by a high ^{14}C age but is non-saline and also contains high contents of both tritium and iodide. This water can therefore be classified as a mixed water containing a smaller component of deep groundwater and a larger component of shallow groundwater which has leaked into the sampling section from the borehole. Mixing of shallow and deep groundwater types has most probably been facilitated by the hydrological characteristics of fracture Zone 1 (i.e. high hydraulic conductivity and positive piezometric head). The high iron content has likely resulted from reactions with the outside surface of the steel piping used to transport the water to the surface. Alternatively, the presence of a nearby fractured greenstone horizon may have contributed groundwaters slightly enriched in iron.

The water sampled from section 483-485 m has a composition which is very similar to that of section 342-344 m, i.e. both contain major portions of shallow groundwater type. The data show that at this level the bedrock is unfractured and that the hydraulic conductivity is low ($< 10^{-11}$ m/s). It is thus highly probable that some portion of the water sampled has leaked into the sampling section around the inflated packers to compensate for the lack of water available from the bedrock section. However, there is still the problem to explain the ^{14}C age differences between

this level and the above section at 342-344 m. As mentioned above, both water types exhibit similar chemistries and similar tritium values and these characteristics suggest a dominant shallow groundwater type. However the difference in ^{14}C age indicates that in one case a significantly large portion of very old water is also present; less marked in the other. A possible explanation to these observations is that during open-hole conditions a component of very old groundwater (not necessarily from the deepest saline variety) enters the borehole at the Zone 1 intersection and mixes with the near-surface and shallow ground waters. Considerable dilution of the older component will result in a lower apparent ^{14}C age. This water will tend to dominate the composition of the water sampled at the 483-485 m level. Subsequently, when the sampling equipment is raised to the 342-344 m level and the packers inflated around the sampling section, a greater portion of the older water component will thus be obtained resulting in a water of similar chemistry but greater ^{14}C age.

The indications are, therefore, that at least three main water types are present: 1) near-surface and shallow ground waters of a young age, 2) intermediate to deep old groundwaters (non-saline) and 3) deep to very deep old groundwaters (saline).

Table 5.3: Uranium content and theoretical Eh values of the groundwaters from borehole Fj 2.

Level (metres)	Uranium Content (ppb)	Calculated Eh (mV)
123 - 125	0.6	- 150
342 - 344	0.2	- 70
483 - 485	< 0.1	- 80
605 - 607	< 0.2	- 250

The measured uranium content of the groundwater sampled from the Fj 2 borehole is slightly higher in the uppermost level and then systematically decreases to below detection limits in the lowest level. The uranium content of the water, together with the theoretical Eh values calculated from the iron content of the water, is presented in Table 5.3 and Figure 5.10. The figure also contains theoretical uranium solubility curves calculated from crystalline and amorphous UO_2 for three different pH values which cover the range of most groundwater types. It is interesting to note that the values for the two most representative groundwater types (i.e. levels 123-125 m and 605-607 m) plot within the calculated stability limits.

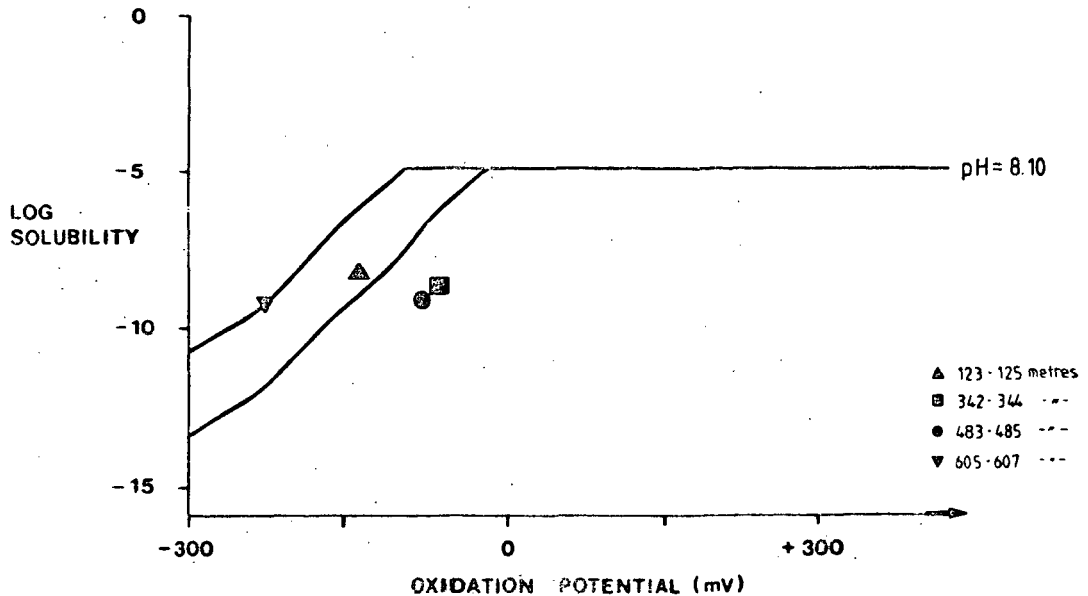

Figure 5.10: Plots of uranium content (expressed as log (mol/litre)) and the calculated theoretical Eh values of groundwaters collected from borehole Fj 2. The values are plotted with respect to theoretical uranium solubility curves calculated for amorphous (lower stability limit) and crystalline (upper stability limit) UO_2 at a pH of 8.10.

5.1.2 Borehole Fj 4

Borehole Fj 4 was drilled at 60° to a vertical depth of 585 m (borehole length 700.50 m) in order to confirm geophysical investigations which had indicated surface expressions of deep-seated fracture zones (i.e. local fracture Zones 3 and 5; Fig. 5.2.). This was achieved between 61-63 m (Zone 5) and 140-192 m (Zone 3); the former is near-vertically orientated (80° - 85°) and the latter is considered vertical. Significant losses of drilling water occurred at 62 m.

The dominant rock-type in the borehole is migmatite gneiss (96.7 % of the borehole length) followed by greenstone (2.3 % of the borehole length) and granite gneiss (1.0 % of the borehole length). The greenstone and granite gneiss occurs as distinct horizons of maximum thicknesses of 4.9 m and 5.9 m respectively. The greenstone horizons occur throughout the drilled core length; granite gneiss appears to be more restricted to below 400 m. The number of fractures/metre recorded, normal for Fjällveden, showed 3.0 for migmatite, 6.4 for greenstone and 5.4 for granite gneiss. Compared to borehole Fj 2 (Figs. 5.3 and 5.11), borehole Fj 4 shows a more distinct contrast between a highly fractured (part crushed and brecciated) upper 200 m, and the lower 200-700 m which exhibits several areas of low fracture density. The highest fracture densities within this lower length interval are mostly associated with the greenstone horizons.

Hydrologically, the bedrock in the near-vicinity of borehole Fj4 is characterised by small hydraulic gradients. The piezometric head is 57 m above sea-level and almost constant down to 400 m before decreasing to 56 m above sea-level towards the bottom of the borehole at 700 m (Fig. 5.11). The direction of the groundwater flow, based on the numerical modelling of Carlsson et al (1983), is uniformly and strongly downwards around the borehole. Only the upper part of fracture Zone 3 indicates a localised upward flow (Fig. 5.12).

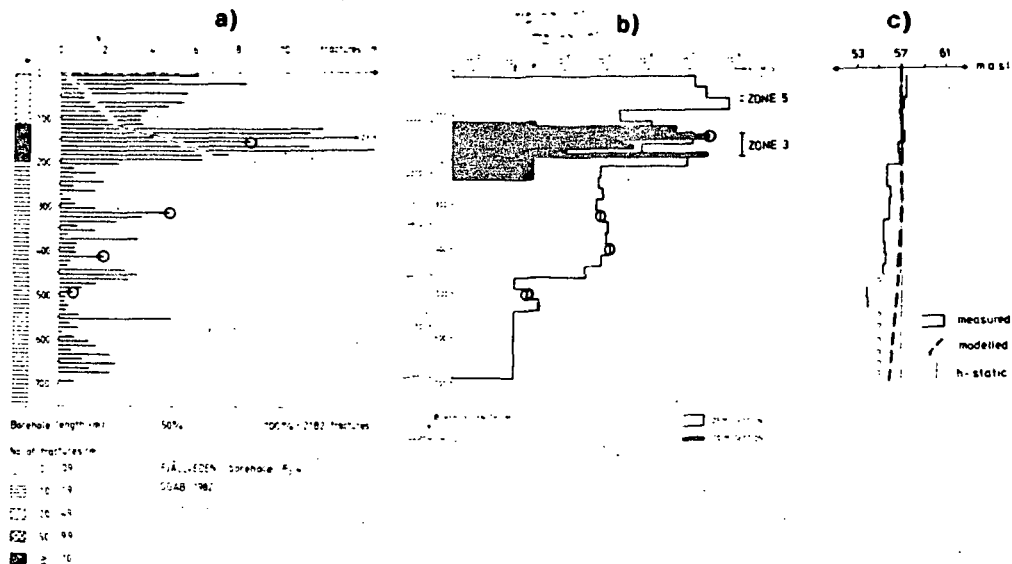

Figure 5.11: Hydrogeological characteristics of borehole Fj4.
 a) Fracture frequency (for 10 m sections) and the cumulative percentage of fractures.
 b) Hydraulic conductivity
 c) Piezometric head distribution and hydrostatic head in the borehole.

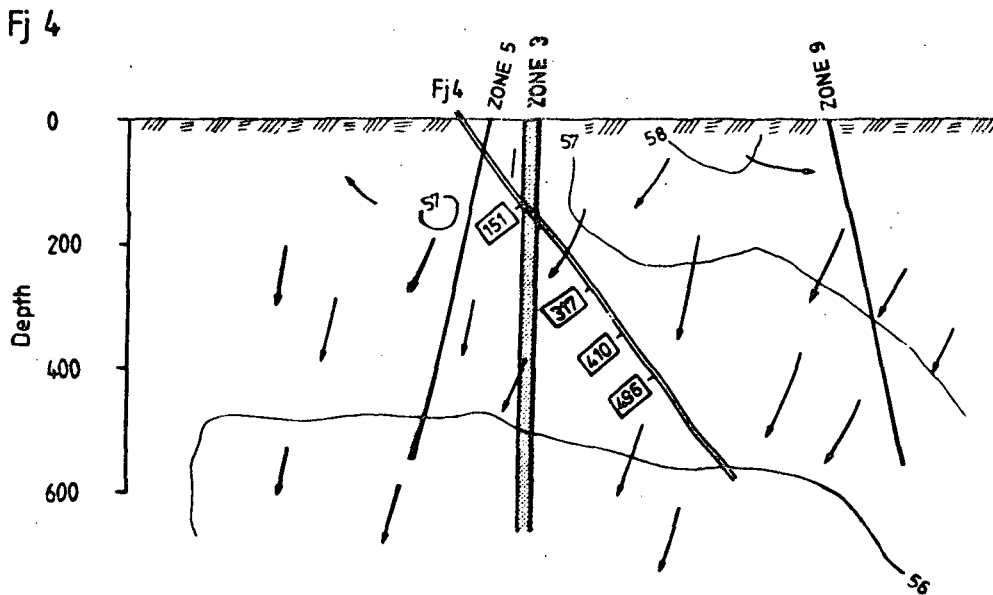

Figure 5.12: The groundwater flow-pattern and isopotentials in the vicinity of borehole Fj 4 illustrated by a vertical section in the same plane as the direction of the borehole (modified after the numerical modelling of the Kemakta Consulting Co).

5.1.2.1 Level 151-153 m (approx. 131 m)

The sampled section represents part of fracture Zone 3 which extends approximately from 140-190 m. Two rock-types are represented within the section: the dominant dark-grey migmatite and a coarse-grained pink pegmatite. Two distinct fracture zones occur varying in width from 25 to 55 cm (i.e. 9 to 17 fractures respectively) and one narrow crush zone some 2 cm in width; these all occur within the migmatite. In contrast the pegmatite is characterised by 5 to 6 single fractures. Generally the fractures intersect the axis of the core at angles ranging from 20° to 90° , and the main infilling mineral phases include chlorite, calcite and pyrite.

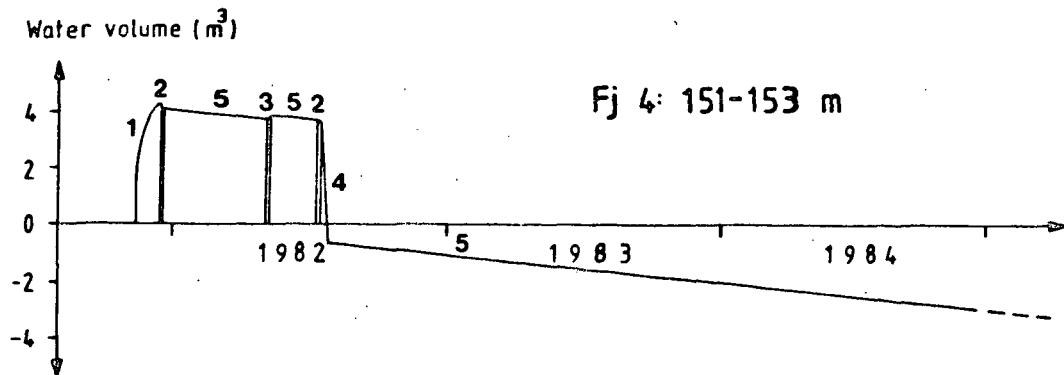

Figure 5.13: Schematic illustration of the calculated water budget for level 151-153 m in borehole Fj4 (Fjällveden). 1 = Drilling water; 2 = Gas-lift pumping; 3 = Hydraulic testing; 4 = Sampling; 5 = Open-hole effect.

Hydrology

The water-sampled horizon is characterised by a hydraulic conductivity of $1.2 \cdot 10^{-7}$ m/s and a piezometric head excess of 0.1 metres. Injection tests carried out along 10 m sections confirm these data and show that the horizon selected lies within the most conductive 10 m section. From water budget considerations (Table 5.4a; Fig. 5.13) the contaminating influences of the drilling and other borehole activities should have been removed during the sampling period and therefore the groundwater should be representative.

Water geochemistry

The sampled water (Table 5.4b) recorded a laboratory pH of 8.2; no field measurements are available. The major cations Na^+ and Ca^{2+} and anions HCO_3^- and Cl^- are present in normal concentrations for non-saline groundwaters representative of crystalline bedrock areas in Sweden (Table 5.1). The presence of 6% I^- is high and represents a significant component of drilling water contamination.

Redox-sensitive parameters

The presence of small amounts of S(-II) and Fe(II) indicate an overall reducing environment. This is partly supported by an Eh value of -70 mV although partly off-set by trace amounts of oxygen (0.04 mg/l).

Isotope geochemistry

The water is characterised by a $\delta^{18}\text{O}$ value of -11.50 ppt; no $\delta^2\text{H}$ is available. The ^{14}C data indicate an age of 3950 years and the tritium content of 9 TU shows a significant component of young, near-surface water.

Uranium geochemistry

The water contains 3.5 ppb uranium and records an isotopic activity ratio of 4.1 which is a high value and indicates widespread disequilibrium in the sampled water.

Summary

The hydrologic data indicates that the sampled groundwater should be largely free of all contamination resulting from the borehole activities. However, the chemistry of the waters showed:

- residual water from drilling activities (i.e. high I^- content).
- water from a younger, near-surface source (i.e. significant tritium content).

This shows that the pumping carried out immediately prior to, and during sampling, was inadequate to remove all water contamination derived from other sources. This may have been achieved over a longer pumping time as suggested by the variation in chemistry during the period of sampling. This showed small but significant increases in Na^+ , HCO_3^- and conductivity, and decreases in Ca^{2+} , $Fe(II)$ and Eh; small increases in oxygen were also noted (Laurent, 1983a). However, these variations, which on one hand suggest an increasing reducing component, and on the other hand an increasing, more oxidising near-surface component (further supported by a moderate tritium content), probably accurately reflect the complexity of characterising waters from such large-scale fracture zones as Zone 3, which can intersect different groundwater physicochemical environments at varying depths.

5.1.2.2 Level 317-319 m (approx. 272 m)

This level chosen for water sampling is completely contained within a greenstone horizon which extends from 316-321 m. The section is characterised mainly by two narrow fracture zones (20 and 25 cm wide) containing 3 and 5 fractures respectively. These, together with two single fractures, intersect the core axis at angles of 15° - 80° ; the main infilling mineral phases are chlorite and calcite.

Hydrology

The sampled section is located central to the sector of the borehole where the hydraulic conductivity is reasonably uniform (i.e. just below 1.10^{-9} m/s). The piezometric head is -1.1 metres of water. As no detailed water injection tests were performed along the 25 m section, it is unclear if the hydraulic properties and the corresponding water-budget calculations (Fig.5.14; Table 5.4a) are representative for the sampled level. It is known from experience that dykes or rock horizons of differing composition and physical properties (e.g. in this case the greenstone) often have a greater fracture frequency and are correspondingly more conductive.

Water geochemistry

The water sampled recorded a laboratory measured pH of 7.5. The major cations Na^+ and Ca^{2+} , although still indicating contents within the range of non-saline groundwaters, show lower Na^+ and higher Ca^{2+} than the shallower level just described. Of the anions, HCO_3^- recorded a slightly lower value and Cl^- a small increase. The presence of 4.4% I^- is still fairly high and shows that drilling water is present.

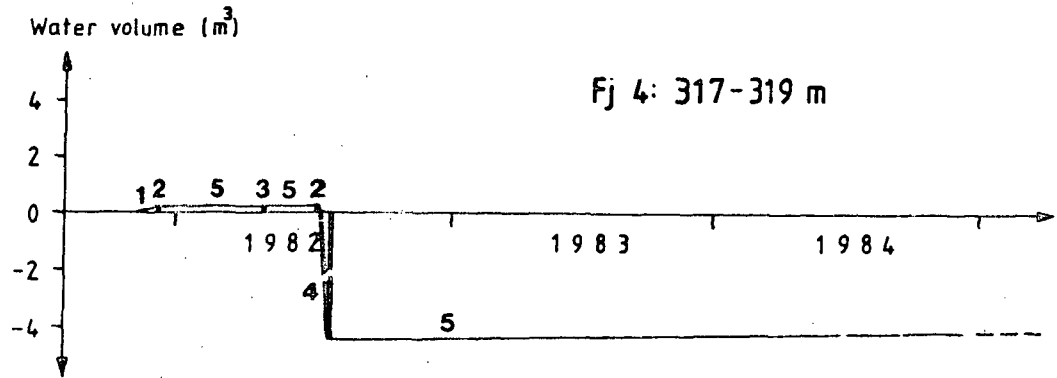

Figure 5.14: Schematic illustration of the calculated water budget for level 317-319 m in borehole Fj4 (Fjällveden). 1 = Drilling water; 2 = Gas-lift pumping; 3 = Hydraulic testing; 4 = Sampling; 5 = Open-hole effect.

Redox-sensitive parameters

A reducing environment is indicated by the presence of S(-II) and Fe(II); the latter is anomalously high (5.7 mg/l). This is supported by an Eh value of -85 mV although trace levels of oxygen (0.04 mg/l) are still present.

Isotope geochemistry

The water is characterised by a $\delta^{18}\text{O}$ value of -11.57 ppt and a $\delta^2\text{H}$ value of -82.6 ppt; this confirms a meteoric origin to the water (Fig. 5.6). The tritium content is higher (19 TU) and the ^{14}C age (3475 years) correspondingly lower than the previous shallower level sampled.

Uranium geochemistry

The uranium content of 3.0 ppb is only slightly lower than the previous level, although the $^{234}\text{U}/^{238}\text{U}$ activity ratio is more markedly reduced to 2.0.

Summary

The results from this level indicate a water characterised by:

- the presence of residual water from borehole activities (aided by a negative piezometric head).
- mixed water sources from within the borehole; this includes a considerably younger near-surface component.

Drilling water contamination is indicated by a significant iodine content; a younger near-surface component is indicated by a high tritium value and further supported by the major ion chemistry (i.e. higher Ca^{2+} lower Na^+ etc.). The high uranium value of 3.0 ppb would also suggest a near-surface water component. The high iron content is unusual and may reflect the greenstone horizon which appears to be conducting the water. Alternatively, it may be due to a reaction of the borehole water with the outer surface of the steel piping above the packers, which has subsequently leaked into the sampled section during pumping. This is supported by the low hydraulic conductivity recorded for the sampling section. The chemical composition of the water has remained uniform during the sampling period.

5.1.2.3. Level 410-412 m (approx. 349m)

The section investigated is comprised of the dark-grey migmatite. Only four isolated single fractures (5 mm wide) characterise the section, intersecting the core axis at angles ranging from 50° - 60° ; pyrite is the most readily identifiable infilling mineral phase present. More major fracture zones (up to 1 m wide) occur some 5 metres away at a depth of 417 m.

Hydrology

Hydraulically, this level represents the same sector as that of the preceding level (Fig. 5.11). The hydraulic conductivity is $1.3 \cdot 10^{-9}$ m/s and the hydraulic head is -1.5 metres; the water flowing into this level almost certainly has its source higher up in the borehole.

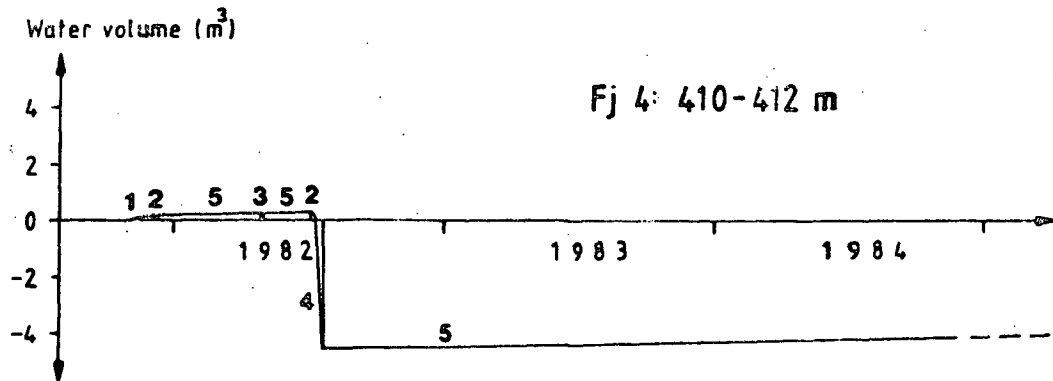

Figure 5.15: Schematic illustration of the calculated water budget for level 410-412 m in borehole Fj4 (Fjällveden). 1 = Drilling water; 2 = Gas-lift pumping; 3 = Hydraulic testing; 4 = Sampling; 5 = Open-hole effect.

The lack of detailed information on the hydraulic parameters introduces some uncertainty into the water budget calculations, even though the fracture frequency within the level is representative of the measured 25 m section as a whole. The low hydraulic conductivity means that it is the water sampling procedure which is responsible for the negative water budget, i.e. all the water introduced as a result of the borehole activities is removed before the water sample is taken (Fig. 5.15).

Water geochemistry

The laboratory pH recorded a value of 9.3. Na^+ , Ca^{2+} , Cl^- and HCO_3^- are present in similar amounts to those recorded for the uppermost level. The presence of 4.3% I^- still indicates a significant amount of drilling water.

Redox-sensitive parameters

The Eh value of -100 mV indicates a further increase in reducing conditions with depth. The Fe(II) is still high (6.5 mg/l) although the S(-II) has decreased somewhat from the previous level. The oxygen content is below the limits of detection.

Isotope geochemistry

The stable isotope values indicate a meteoric origin to the water (Fig. 5.6); the presence of tritium (12 TU) shows a significant young component involved. The ^{14}C data records a much older water (5535 years) than either of the two previous levels.

Uranium geochemistry

Only a small amount of uranium is present (0.63 ppb) when compared to the previous two levels; no isotopic data are available.

Summary

The results indicate that the sampled water is characterised by:

- residual waters derived from borehole activities.
- a younger water component derived from a near-surface level.
- an older groundwater as suggested by the ^{14}C data.

It would appear that the water budget prediction of a representative groundwater being possible from this level has not been realised.

Because of the low K-value and the geological features of the section, it is almost certain that much of the water sampled originates from higher levels within the borehole. This is supported by the tritium content and the high Fe(II) content, both of which characterised the preceding level. However, the ^{14}C age of the water, the lower Eh values and the virtual absence of oxygen, would suggest a deeper groundwater component.

Analytical trends in water composition during sampling (Laurent, 1983a), show a steady increase in Ca^{2+} , Mg^{2+} , SO_4^{2-} and conductivity, and a decrease in Na^+ , HCO_3^- , Cl^- and I^- . This would suggest that the initial groundwater sampled was gradually replaced by an increasing amount of shallower groundwater, still of a reducing character.

5.1.2.4. Level 496-498 m (approx. 420 m)

The sampled section is located within a length of unfractured, fresh, dark-grey migmatite. The nearest significant fracture zone (40 cm in width and containing some five fractures) is at approx. 499 m depth and associated with a greenstone horizon.

Hydrology

This bedrock section is characterised by very low hydraulic conductivities (Fig. 5.11) near the limits of measurement. The calculation of the hydraulic head is therefore somewhat uncertain. The water volume injected into the bedrock from the borehole activities probably corresponds to the fractured greenstone horizon located about 0.7 m below the sampled level. Calculation of the water budget, though not representative of the level, is illustrated in Fig. 5.16.

Groundwater geochemistry

The pH of the sampled water is 8.4; Na^+ , Ca^{2+} , HCO_3^- and Cl^- are all present in normal amounts for non-saline groundwaters. Low amounts of I^- (0.7 %) indicate the absence of any significant amounts of drilling water.

Redox-sensitive parameters

The presence of Fe(II), relatively high S(-II), and the general absence of oxygen together with an Eh value of -160 mV, indicate the most reducing water measured from this borehole.

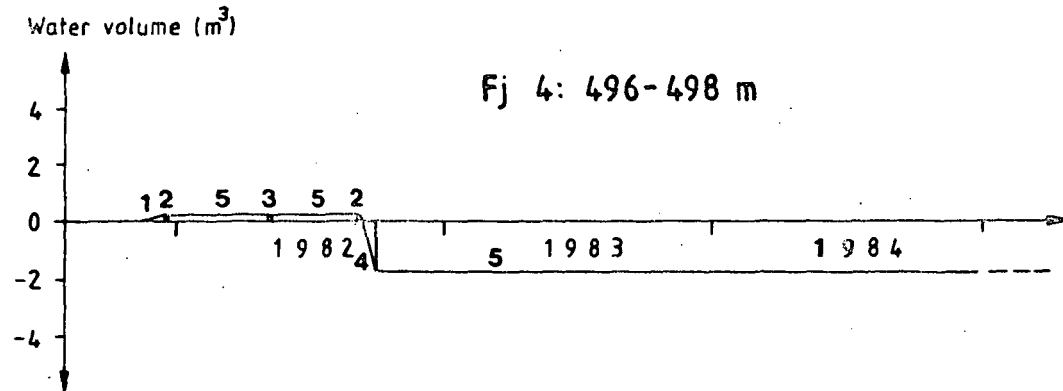

Figure 5.16: Schematic illustration of the calculated water budget for level 496-498 m in borehole Fj4 (Fjällveden). 1 = Drilling water; 2 = Gas-lift pumping; 3 = Hydraulic testing; 4 = Sampling; 5 = Open-hole effect.

Isotope geochemistry

The stable isotope data ($\delta^{18}\text{O} = -11.88$ ppt and $\delta^2\text{H} = -84.7$ ppt) indicate a meteoric water origin (Fig. 5.6). Both the low tritium content (6 TU) and the old age of the groundwater (6850 years) suggest a major portion of old groundwater with a minor component of younger water.

Uranium geochemistry

The uranium content lies below the level of detection (< 0.2 ppb); no isotopic data are available.

Summary

The results show that the sampled groundwater is characterised by:

- a general absence of drilling water.
- a minor component of younger, near-surface water.
- a major, old groundwater portion, probably representative for the sampled depth.

From hydrogeological considerations, most of the sampled water must have come from sources other than the section of the borehole sampled. The two most likely sources are the borehole waters above and below the packed-off section. Analytical trends in water composition during sampling (Laurent, 1983a) are very revealing. These show a very marked decrease within the first two days of sampling of Na^+ (100 to 62 mg/l), Ca^{2+} (21 to 13 mg/l), Fe(II) (3.3 to 1.3mg/l), Cl^- (220 to 30 mg/l), I^- (4.8 to 2.2 $\mu\text{g/l}$) and conductivity, and increases in HCO_3^- and SO_4^{2-} . This indicates that a limited amount of old saline groundwater (which still retains some I^- from the initial drilling period) is quickly removed from the section and increasingly replaced by younger waters derived from higher levels within the borehole and uncontaminated by drilling water.

5.1.2.5. Borehole summary and discussion

Geological mapping and hydrological investigations along 25 m sections in the borehole (at one level more detailed measurements were made along 10 m sections), have resulted in the sampling of groundwater from four levels. The most promising level (151-153 m), due to positive head deviation, represents the intersection of the borehole with fracture Zone 3 (140-192 m); a less promising level was located at 317-319 m, and the lowest two levels were the most doubtful.

The natural groundwater flow around the borehole is downwards; this is evident at Zone 3 which records a marginal positive piezometric head. Otherwise the lower three levels show negative values along the measured 25m sections. In general, the water budget calculations suggest that representative groundwater samples should be obtainable from all four demarcated levels. However, only in the uppermost level (151-153 m) is it thought that the water budget values (i.e. based on 25 m sections) are directly applicable to the 2.7 m borehole lengths actually sampled.

The hydrologic promise of the fracture Zone 3 level was not reflected by the water chemistry which indicated a mixture of water sources. The major water component is thought to be a shallow reducing groundwater with significant amounts of residual water from the various borehole activities. A younger, near-surface component is also indicated by the tritium content. As pointed out above, groundwater mixing is probably inevitable within these deeply penetrating local fracture zones which must intersect and form conducting channels between different groundwater environments.

From the water budget calculations the second level (317-319 m) appears to be less promising because; 1) the fractured greenstone is much broader (5 m) than the sampled section, 2) an overall low K-value for the 25 m measured section and, 3) a negative piezometric head. This means that there is a high probability that borehole water will be pumped around the packers, i.e. directly or via a suitable fracture network, to the sampling section. As the uppermost level is characterised by a positive piezometric head and shallow groundwater composition, one might expect such a composition to dominate the borehole water. However, the chemistries are sufficiently different to show that the dominant water in the borehole at the second level is of a younger, near-surface water origin, and must therefore have come from a higher level than the uppermost level sampled.

The two lowermost levels sampled are similar in that they are both characterised by K-values which are too low to result in adequate volumes of groundwater for sampling purposes. The effect of pumping is clearly seen from the trends in water composition during sampling. In both cases there is a rapid response, after the first day or so, resulting in less saline groundwater of the same composition, i.e. reducing shallow groundwater types similar to those entering the borehole at level 151-153 m at the fracture Zone 3 intersection. It would thus appear that these borehole waters are being leaked into the sampling section from around the packers. The initial more saline water removed (especially marked in the lowermost level; very much weaker in the overlying level) probably gives some very qualitative idea of the true groundwater composition at these levels, although the high I^- content in both cases may denote a significant drilling water component. The greater percentage of deep reducing groundwater at these two levels is reflected by lower tritium and older ages derived from the ^{14}C data than the Zone 3 level. Moreover, the uranium is present as low to trace amounts at both the lowermost levels, suggesting strongly reducing conditions.

In summary, the major groundwater types represented by borehole Fj4 are: 1) near-surface and shallow ground waters of a young age, 2) intermediate to deep old ground waters (non-saline) and 3) the possibility of very deep old groundwaters (saline). Unfortunately, none of the groundwaters collected from the four levels can be considered truly representative.

The uranium contents of the sampled waters from borehole Fj4 decrease with increasing depth. There is a clear distinction between the two uppermost (3.66 and 3.03 ppb U) and the two lowermost levels (0.63 and <0.2 ppb U). The analytical contents, together with the theoretical Eh values calculated for the iron system, are presented in Table 5.5 and Figure 5.17. The figure also contains theoretical uranium solubility curves calculated from

crystalline and amorphous UO_2 for a pH of 8.1 which is reasonably representative for the waters from the borehole Fj4. All four water compositions plot within the uranium solubility boundaries.

Table 5.5: Uranium content and theoretical Eh values of the groundwater from borehole Fj4.

Level (metres)	Uranium Content (ppb)	Calculated Eh (mV)
151 - 153	3.66	-120
317 - 319	3.03	-130
410 - 412	0.63	-150
496 - 498	< 0.2	-260

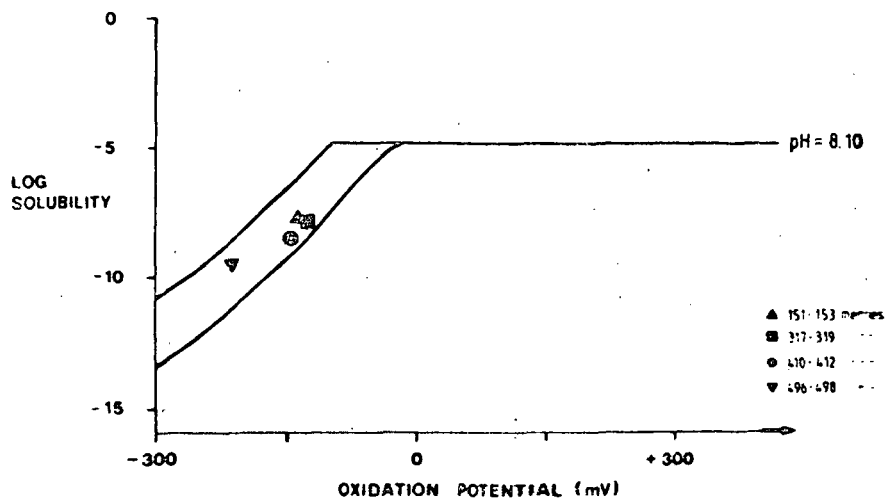

Figure 5.17: Plots of uranium contents (expressed as log (mol/litre)) and the calculated theoretical Eh values of groundwaters collected from borehole Fj4. The values are plotted with respect to theoretical uranium solubility curves calculated for amorphous (lower stability limit) and crystalline (upper stability limit) UO_2 at a pH of 8.10.

5.1.3 Borehole Fj8

Borehole Fj8 (borehole length 731.80 m and vertical depth 615 m) was drilled at 60° to investigate the underlying bedrock mass; there were no surface geophysical indications of any large scale structural weaknesses within the near-vicinity of the borehole. The drilled bedrock was generally weakly fractured and no crush zones were encountered.

Typically for the Fjällveden area, the dominant rock-type is migmatite (95 % of borehole length) containing up to 6 granite gneiss horizons (2.7 % of borehole length; max. thickness 7.45 m) and several zones of amphibolitic greenstone (2.3 % of borehole length; max. thickness of 2.70 m). The greenstone occurs throughout the drilled length whilst granite gneiss tends mostly to occur at the very top or at depths greater than 500 m.

The average fracture frequency/metre for the total borehole is 1.9 fractures/metre. Of the individual rock-types, granite gneiss exhibits the greatest frequency/metre (7.0), followed by the greenstone (4.3) and lastly the migmatite (1.7). Figure 5.16 shows that zones of higher fracture frequency occur between 460-480 m and around 660 m and 690 m, all of which can be explained by horizons of granite gneiss.

Hydrologically, borehole Fj8 penetrates a groundwater transition zone whereupon the direction of flow changes from downward-penetrating to upwards (Fig. 5.18). On the section illustrated in Figure 5.18, the downward flow is directed towards the borehole. Considering the situation in three dimensions, the flow is towards Zone 10 (i.e. inwards through the plane of the section which is inclined towards the plane of the section). The hydraulic head along the borehole initially drops rapidly from 59 metres above sea-level at the bedrock surface down to 200 metres; after this the drop is more gradual resulting in

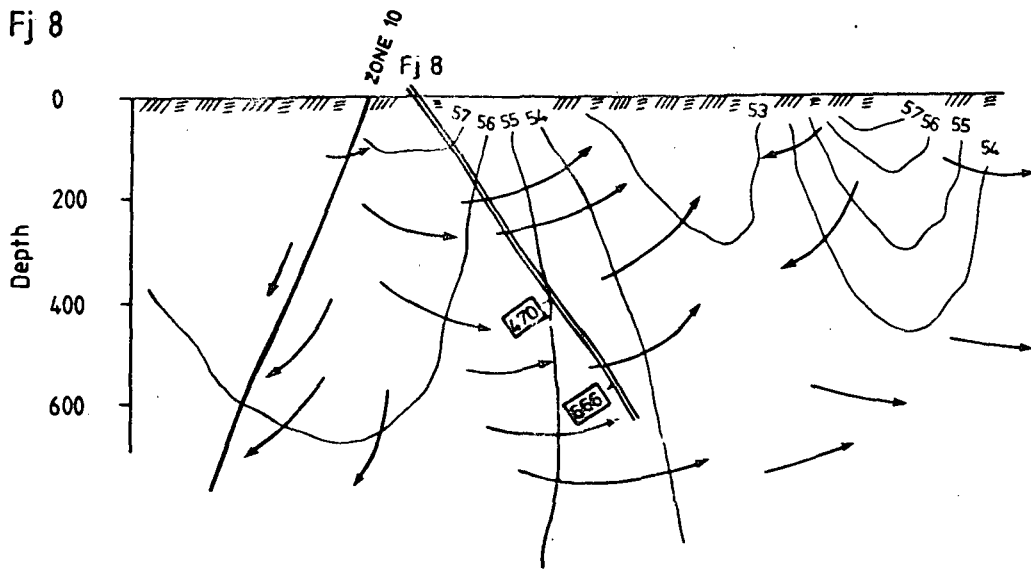

Figure 5.18: The groundwater flow-pattern and isopotentials within a vertical section along borehole Fj8 obtained from numerical modelling (modified after the numerical modelling of the Kemakta Consulting Co).

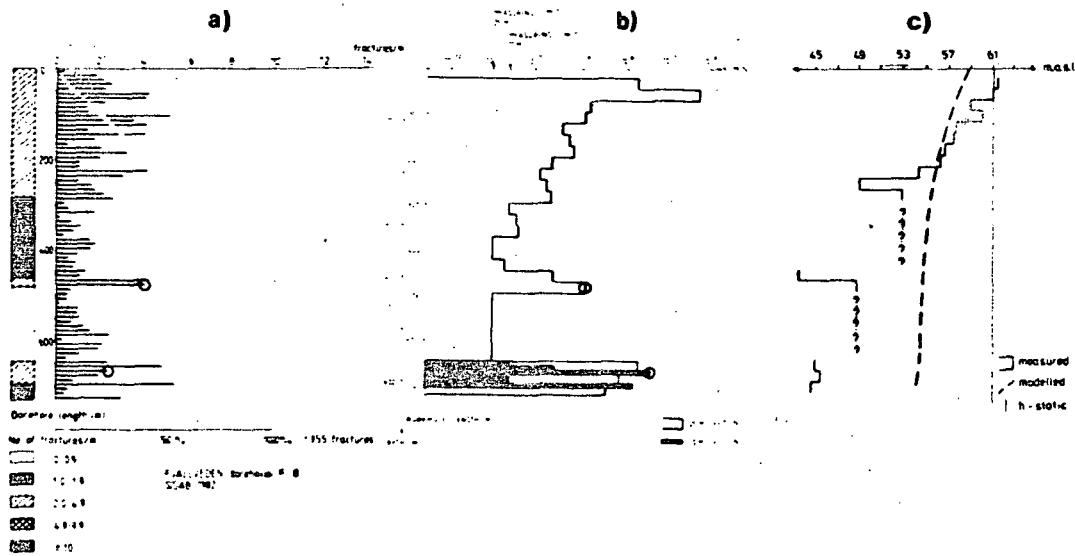

Figure 5.19: Hydrogeological characteristics of borehole Fj8.
 a) Fracture frequency (for 10 m sections) and the cumulative frequency of fractures
 b) Hydraulic conductivity
 c) Piezometric head distributions and hydrostatic head in the borehole

a head of about 54 metres above sea-level at the bottom of the borehole. The natural piezometric heads derived from the hydraulic testing are illustrated in Figure 5.19; it is noticeable that the head gradient along the borehole is much greater than that obtained from the numerical modelling. The measured results are confirmed by detailed injection tests and also by multi-packer piezometric measurements (Ahlbom et al 1983b). These somewhat surprisingly low hydraulic heads are interpreted as having been caused by highly conductive layers of granite gneiss which intersect the boreholes (Ahlbom et al 1983b).

5.1.3.1 Level 470-472 m (approx. 402 m)

The sampled section core is characterised by dark-grey migmatite containing some 10 single fractures (average of 5 mm wide) distributed fairly evenly along the section. These fractures intersect the axis of the borehole at angles ranging from 24° to 50° ; the main infilling mineral phases are calcium, chlorite and pyrite.

Hydrology

The sampled level represents a section of the borehole characterised by increased hydraulic conductivity; at greater and lower levels the bedrock records very low K-values (Fig. 5.19). The unusually low hydraulic head results in a significantly marked open-hole effect even though the K-value ($1.2 \cdot 10^{-9}$ m/s) is not especially high. The various influencing activities and the calculated water budget for the level are presented in Table 5.6a and Figure 5.19. The values quoted in Table 5.6a are believed to be an over-estimation because the K-value of the sampled level is supposed to be lower than the measured value. It is highly probable that the most conductive part of the 25 m section is represented by the 5 m horizon of granite gneiss located outside the sampled area (i.e. 2 m below).

From the overall water budget (Fig. 5.20) it can be seen that the open-hole effect plays an important role, although the indications are that the contaminating influence of a water influx from the borehole into the sampled zone is removed whilst sampling, especially during the latter part of the sampling period.

Water geochemistry

The sampled water (Table 5.6b) has a pH of 8.6; the contents of the major anions HCO_3^- and Cl^- , and cations Na^+ and Ca^{2+} , are generally lower than the previous two drillholes although still characteristic of non-saline groundwaters. Significant iodine (5.5 % I^-) indicates a drilling water component.

Redox-sensitive parameters

Significant amounts of Fe(II), an Eh value of -110 mV, and low O_2 (0.02 mg/l), indicates a reducing environment.

Isotope geochemistry

The $\delta^{18}\text{O}$ and $\delta^2\text{H}$ isotopic values (-11.21 ppt and -79.3 ppt respectively) confirm a meteoric water source (Fig. 5.6). The ^{14}C data indicates an age of some 3980 years, whereas the tritium analysis gives 8 TU indicating an appreciable portion of younger, near-surface water.

Uranium geochemistry

The amount of dissolved uranium is 1.10 ppb (DNA) and 0.90 ppb (alpha-spectrometry) with an $^{238}\text{U}/^{235}\text{U}$ activity ratio of 3.5, indicating widespread disequilibrium.

Summary

The results show that the sampled water is characterised by:

- a considerable portion of drilling water (i.e. 5.5 mg/l I⁻).
- a portion of young, near-surface water (i.e. generally low ¹⁴C age and moderate tritium content).

These observations might be explained by the low hydraulic conductivity of the sampled section; it is doubtful as to whether adequate water was available from the packed-off bedrock section. As a consequence, a large portion of borehole water (of a shallow, younger origin) containing residual drilling water has been leaked past the packers during sampling.

5.1.3.1. Level 666-668 m (approx. 562 m)

The sampled section is contained within a 7.5 m thickness of fine-grained, grey granite gneiss. Apart from one marked fractured zone (25 cm wide and comprising 5 fractures) the section is characterised mostly by single fractures (a total of 5) approximately 5 mm in width. The fractures intersect the plane of the borehole at angles ranging from 30⁰-45⁰, and the main mineral filling phases are calcite, chlorite and pyrite.

Hydrology

The sampled section represents part of a 25 m borehole length characterised by a high hydraulic conductivity ($K=1.9 \cdot 10^{-8}$ m/s). For such depths this is an unusually high value and, as clearly shown by the detailed injection tests, is caused by the presence of granite gneiss horizons (Ahlbom et al 1983b).

The combination of a low hydraulic head and a high K-value results in an extreme open-hole effect as illustrated in Figure 5.21. From a sampling point of view, the Figure shows that very long sampling pump times are necessary to remove all contaminating waters. This condition has not been fulfilled, and so the water sampled from this level should represent a mixture of water types from different sources.

Water geochemistry

The sampled water records a pH value of 8.9; the contents of the major anions HCO_3^- and Cl^- , and cations Na^+ and Ca^{2+} , are similar to the above-described level. Although the I^- content is lower (4.7 %) it still represents an appreciable portion of drilling water.

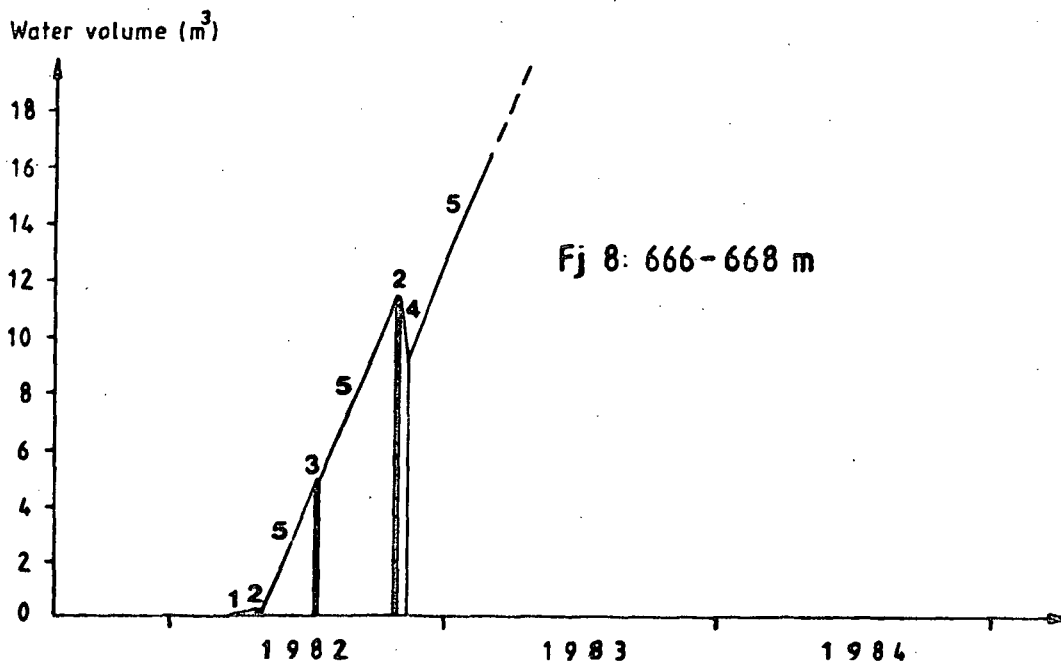

Figure 5.21: Schematic illustration of the calculated water budget for level 666-668 m in borehole Fj 8 (Fjällveden). 1 = Drilling water; 2 = Gas-lift pumping; 3 = Hydraulic testing; 4 = Sampling; 5 = Open-hole effect.

Redox-sensitive parameters

The presence of 3.2 mg/l Fe(II) and the absence of any significant oxygen indicate reducing conditions. This is further supported by an Eh value of -140 mV.

Isotope geochemistry

The stable isotope data (-11.16 ppt $\delta^{18}\text{O}$ and -77.8 ppt $\delta^2\text{H}$) indicates a meteoric water origin (Fig. 5.6). The ^{14}C data signifies an age of 3975 years and the tritium content (10 TU) suggests a younger, near-surface water component.

Uranium geochemistry

A slightly lower dissolved uranium content (0.43 ppb by DNA, 0.60 ppb by alpha-spectrometry) and a slightly higher $^{234}\text{U}/^{238}\text{U}$ activity ratio (3.8), distinguishes this sampled level from the previous one.

Summary

Apart from minor differences in pH, and the contents of Fe(II), uranium and I^- , the water from this level is similar to that described previously. The water budget indicates a very large open-hole effect due to the low piezometric head and high hydraulic conductivity. The sampled water thus represents the borehole water which has previously penetrated the fractured horizon, and consequently is similar in type to that from the upper horizon.

5.1.2.5 Borehole summary and discussion

On the basis of geological and hydrological investigations, two levels were selected for water sampling purposes. In both cases the hydraulic properties measured and described are influenced to a major degree by the granite gneiss horizons. These are generally highly fractured, and are believed to extend for considerable distances into the bedrock parallel to the regional structural trend, i.e. usually along the isoclinal fold axes.

The hydrological data generally indicate a relatively strong downward groundwater gradient around the vicinity of the borehole. Measurements from the two borehole levels indicate a very low piezometric pressure. This feature combined with a low hydraulic conductivity within level 470-472 m, has resulted in a limited water influx into the bedrock during open-hole conditions, although the water budget calculations indicate that this should be adequately removed during the initial stages of sampling. For the lowermost level at 666-668 m, the low piezometric head in combination with a high hydraulic conductivity has resulted in a considerable water influx into the fractured bedrock horizon. The water budget calculations show that only a small fraction of this water is removed by gas-lift pumping and pumping prior to sampling. The sampled water from this zone should therefore represent a mixture of water types from different sources.

The chemistry of the water sampled from the two levels is essentially the same, i.e. shallow groundwater type, often characteristic of that associated with the local fracture zones. This suggests the possibility of a hydraulic connection from the borehole to a local fracture zone - most likely Zone 8 (Fig. 5.2). The most obvious connection is via the granite gneiss horizons which, as pointed out above, are usually fractured, highly conducting, and can be traced for considerable

distances parallel to the regional structural trend. Because of the negative piezometric head present at both levels, appreciable quantities of drilling water are also present within the sampled waters.

In conclusion, the waters represented in borehole Fj8 comprise: 1) a residual drilling water component, 2) reducing shallow groundwaters possibly originating in a nearby local fracture zone, and 3) a young, near-surface component which may partly represent the drilling water source.

The uranium content of the waters collected at the two levels indicate a decrease with depth. In Table 5.7 and Figure 5.22 the analytical uranium content and the theoretically calculated uranium solubilities for both crystalline and amorphous UO_2 at a pH of 8.1 and 9.3 are presented and plotted as a function of Eh. Both water compositions plot along the crystalline UO_2 solubility curve at a pH of 9.3.

Table 5.7: Uranium content and theoretical Eh values of the groundwater from borehole Fj8.

Level (metres)	Uranium Content (ppb)	Calculated Eh (mV)
470 - 472	1.10	-240
666 - 668	0.43	-320

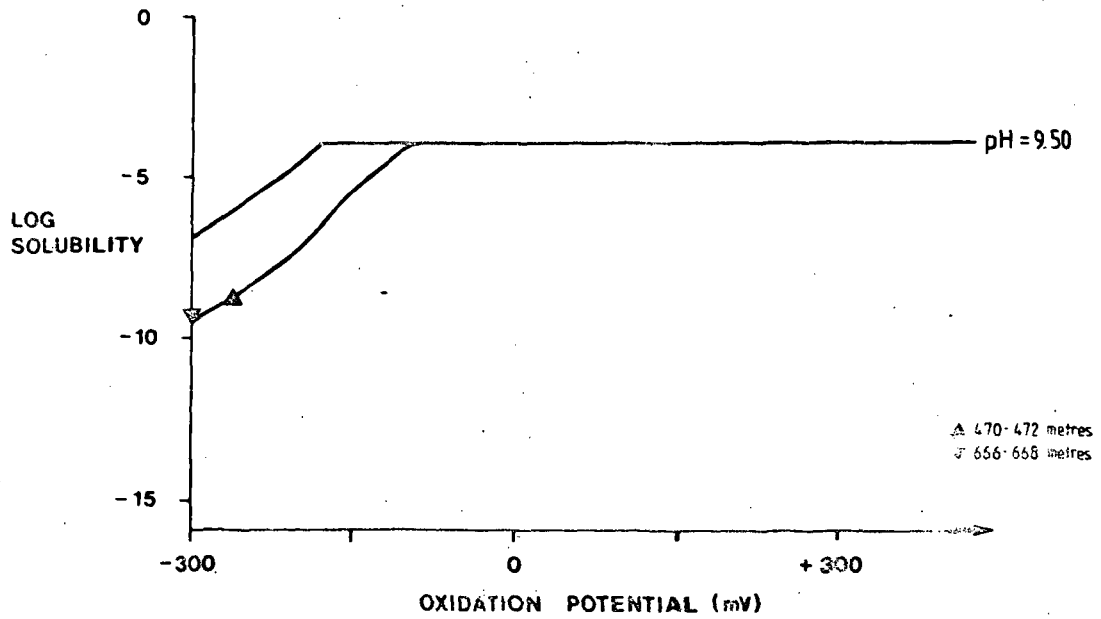

Figure 5.22: Plots of uranium contents (expressed as log (mol/litre)) and the calculated theoretical Eh values of groundwaters collected from borehole Fj8 (Fjällveden). The values are plotted with respect to theoretical uranium solubility curves calculated for amorphous (lower stability limit) and crystalline (upper stability limit) UO_2 at a pH of 8.10 and 9.3.

5.2 Gideå

The Gideå test-site is situated in the county of Ångermanland about 480 km north of Stockholm and approximately 10 km from the Baltic coast (Fig 1). The coastal areas of this region reflect the highest land isostatic uplift evidenced in Sweden. This has helped to produce a markedly undulatory topography which tends to plane out northwards. The Gideå test-site is located on a flat plateau area enclosed by major fracture-dependent valleys orientated in a north-westerly direction. The differences in altitude in the area are relatively small varying between 80 m and 130 m above sea-level (Fig 5.23).

The regional geology has been recently described by Lundqvist (1980); resulting from SKB investigations carried out in the years 1981-1983 the detailed geology of the Gideå test-site area has been described by Albino et al (1982) and later summarised by Ahlbom et al (1983c). A map of the Gideå test-site area showing the general topographic features and the main structural zones of weakness is illustrated in Fig 5.24.

The geology of the area is dominated by Precambrian migmatitic sedimentary gneisses formed during the Svecokarelian orogeny some 1800-1900 Ma. Metre wide dykes and more massive pegmatite bodies traverse the region in an eastwest direction, as do younger dolerite dykes (approx. 1200 Ma) which are mostly < 1 metre wide; larger dykes are often composite. The gneisses are unevenly migmatized due to primary compositional differences and local melting has resulted in the formation of irregular bodies of migmatized granite (granite gneiss). These tend to be orientated parallel to the regional structural trend.

The veined sedimentary gneiss is usually grey in colour and fine to medium-grained in texture comprising on

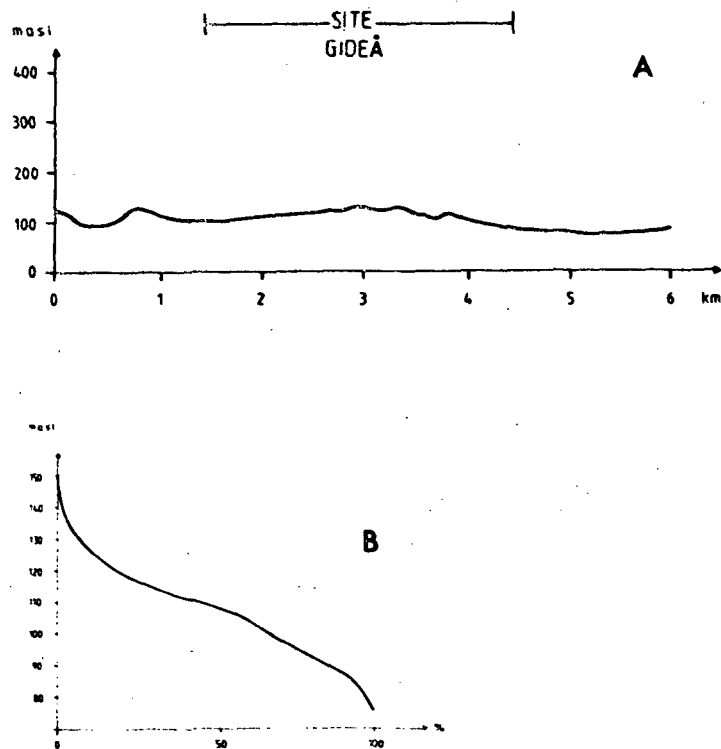

Figure 5.23: The Gideå test-site. A: Topographic profile across the site, B: Hypsographic curve showing altitude characteristics.

average 56 % quartz, 19 % biotite, 13 % plagioclase and 6 % microcline (in vol %). Sulphides in the form of pyrite and pyrrhotite are sporadically present as aggregates or fracture fillings; disseminations and thin enrichments parallel to the regional foliation also occur. Distributed throughout the gneiss are lenses, schlieren and irregular bodies of varying mineralogical composition which usually represent fragments of the original sediment; these also trend parallel to the regional structures. The schistosity varies with the degree of migmatization and appears as a parallel orientation of biotite; the foliation is in a general north-easterly direction with a shallow dip of about 10° - 30° towards the north-west.

As a result of some 24 shallow percussion boreholes (to a maximum depth of 153 m) and 13 deep cored boreholes (to a maximum depth of around 700 m) the granite gneiss is estimated to comprise some 6 % of the total bedrock volume and consists of almost horizontal horizons parallel to the regional foliation. It is typically grey in colour and medium grained.

Structurally the Gideå area is enclosed by near-vertical regional fracture zones striking west-north-west and north-west (Fig 5.24). As estimated from geophysical data the former zones are extensive varying in width in excess of 100 m; the latter zones are generally smaller (50-100 m). Within the investigated area only local fracture zones are present, i.e. those of 15-20 m and 5-15 m in width (Fig 5.24). These have been interpreted from aerial photography, surface geology and geophysics, and shallow and deep drilling. As a result 11 fracture zones have been located with an average width of 11 m; the mutual distance between these local zones ranges from 400-800 m and the general dip varies from 30° - 90° to the horizontal. Down to depths of 100-200 m there exist horizontal tensional release joints; at greater depths no further horizontal fracturing has been observed. The most commonly occurring fracture infilling mineral phases are calcite, chlorite, laumontite, pyrite and clay minerals such as smectite and illite.

Fracturing in the bedrock blocks separating these local fracture zones have been mapped from outcrop and drillcores. Surface fractures have two dominant directions, north and north-east. The latter trend is parallel to the regional foliation exhibited by the gneiss. The frequency of fractures longer than 0.5 m on the outcrops is 1.2 fractures/metre.

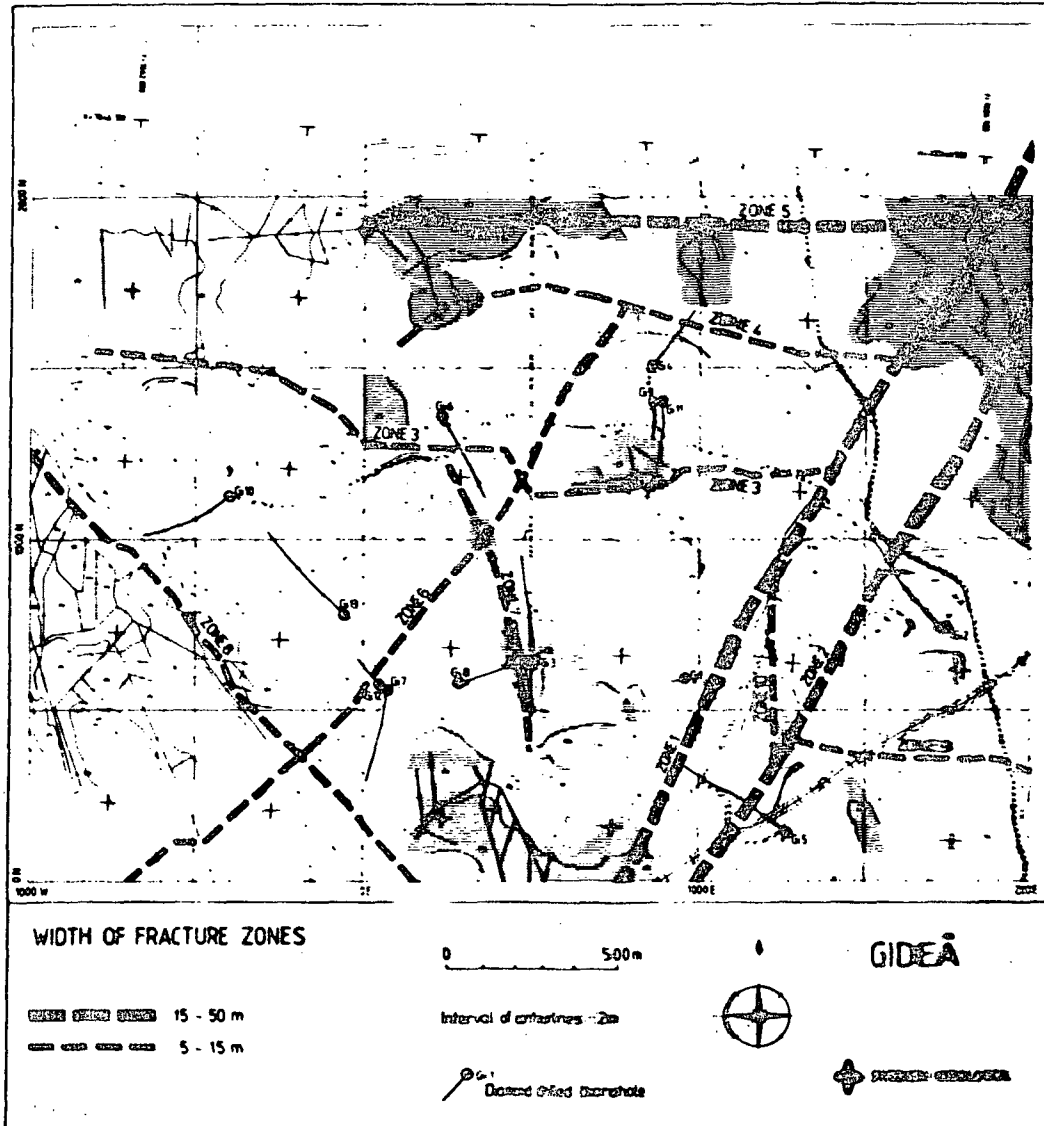

Figure 5.24: Topographic map of the Gidea test-site area showing the main structural zones of weakness and the location of the 13 (G1 to G13) cored boreholes (After Albino et al 1982).

The fracture frequency variation with depth in the rock mass is greater than 4.0 fractures/metre down to 400 m; below 500 m it decreases markedly to 2.0 fractures/metre. The higher fracture frequency of the drillcores as compared to the outcrop measurement is due to the fact that the frequency of horizontal fractures (i.e. tensional release joints) has been underestimated from the outcrops. The drillcore fracture frequency also comprises all fractures irrespective of length; from outcrop measurements all fractures less than 0.5 m have been neglected.

The variation of fracture frequency of the various rock-types, in order of decreasing frequency, is dolerite (20.6 fractures/metre), granite gneiss (7.4) and finally veined gneiss (4.2).

Hydrologically the Gideå site is located on the water divide between two drainage areas. The northern part drains to the north-east into the Husån stream (catchment area of 579 km²), and the remaining area drains to the west into the Gide river (catchment area of 3425 km²); drainage in both areas is via a system of small streams and both the Husån and Gide rivers ultimately drain into the Baltic. The site area contains minor local discharge areas in the low-lying parts, usually characterised by peat bogs.

The water balance of the Gideå site for the period 1951-1980 has been calculated to:

Adjusted precipitation	765 + 25 mm/year
Actual evaporation	410 + 25 mm/year
Run-off	345 + 10 mm/year

The annual precipitation exceeds the sum of the actual evaporation and run-off by about 10 mm which corresponds to 3 % of the run-off. This may be a function of the uncertainty caused by the estimated basic values and should thus be regarded as acceptable. Groundwater

drainage outside the boundaries of the test-site is considered to be negligible. The major portion of the run-off is circulated in the soil horizon and the uppermost part of the fractured bedrock. In the numerical modelling of the groundwater flow in the Gideå test-site the groundwater percolation rate to the bedrock has been calculated to approx. 75 mm/year (Carlsson et al 1983).

The main period of groundwater recharge in the region occurs in the Spring resulting in the largest groundwater level differential of the year. A minor period occurs in the Autumn due to low evaporation in combination with precipitation on the ground which has not yet become impermeable due to freezing. The groundwater temperature in Sweden tends to be uniformly low; at depths of 5-10 m it generally coincides with the annual mean air temperature which at Gideå is just below 5 degrees C (Knutsson and Fagerlind, 1977).

In general, the profile of the groundwater table reflects on a much smoother scale the topographical relief. In the Gideå area the groundwater table is located 1-3 m below the ground surface although in the more hilly parts and adjacent slopes the groundwater level depth can be in excess of 10 m. As a consequence the groundwater level at Gideå varies between 85-120 m above sea-level. The groundwater level profile is dome-shaped, highest in the centre of the site area and falling off towards the marginal boundaries. The greatest gradients are towards the eastern depression which contains the Husån.

5.2.1 Borehole Gi 2

Borehole Gi 2 was drilled at 60° to a vertical depth of 510 m (borehole length of 705 m) in order to confirm the presence of local fracture Zone 1 at depth (Fig 5.24), earlier indicated by the near-surface percussion drilling. In addition, more information was required to adequately describe the occurrence of narrow dolerite dykes which outcropped just north of the drilling site. As a result of drilling fracture Zone 1 was located between 309-335 m; furthermore, more minor crush zones were encountered at depths of 100 m, 199-202 m, 462-505 m and 541-643 m. Dolerite dykes were intercepted at depths of 223-224 m and 398-426 m; in both cases the dykes were associated with fracture/crush zones. At 100 m depth artesian water was encountered.

The dominant rock type traversed by the borehole is migmatitic veined sedimentary gneiss (81.5 length %) followed by migmatite granite gneiss (10.0 length %), pegmatite (5.0 length %) and finally dolerite (3.5 length %). Essentially the borehole section is comprised of veined gneiss with more minor horizons of granite gneiss (2-20 m in extent), up to 28 pegmatite zones (to a maximum thickness of 11.5 m), and 8 dolerite dykes mostly ranging in thickness from 0.35-2.45 m although one recorded 11.5 m. More massive thicknesses of these subordinate rock types tend to occur below 400 m. The number of fractures/metre recorded for this borehole was anomalously high for the area (7.38). The veined migmatite gneiss recorded the lowest fracture frequency (5.74); this was superceded by the pegmatite (7.37), migmatite granite gneiss (10.89), and lastly dolerite (36.10). The dolerite can be considered completely crushed, i.e. an average value of 50 fractures/metre. Related to depth the fracture frequency is uniformly high (average of around 8-10 fractures/metre) with the highest values (15-25 fractures/metre) being recorded between 400-600 m.

The dolerites are usually partly altered to chlorite and the most common fracture filling mineral phases regardless of rock-type are chlorite, calcite, pyrite and laumontite.

The groundwater flow-pattern in the vicinity of the borehole, derived from the numerical modelling of the groundwater flow at the Gideå site by Carlsson et al. (1983), is illustrated by a vertical section in the same plane as the direction of the borehole (Fig 5.25). The borehole is located near the eastern (non-flow) boundary of the modelled area, and therefore the calculated groundwater flow is to some extent influenced by this. As illustrated by Figure 5.25 the groundwater flow that comes in contact with the borehole is directed towards fracture Zone 2; there also exists a directional component along the Zone towards the north, i.e. perpendicular to the plane of the paper.

The modelled head profile, illustrated in Figure 5.26c, together with measured heads from the hydraulic testing along 25 m sections, shows an increasing piezometric head of 1 m from the surface to a depth of 50 m implying that the upper bedrock horizon constitutes a discharge area; this is supported by the artesian water encountered at approx. 100 m during drilling. Down to a depth of 400 m the head decreases from 107 to 102 m above sea-level; at greater depths it is almost constant. The measured head profile is in general agreement with these values, significant deviations only occurring at 330-530 m along the borehole whereupon values are much lower. A qualitative estimation of the flow directions for the circulating groundwater in the borehole, together with the calculated water budget resulting from the various borehole activities, is compiled in Table 5.8a.

The hydraulic conductivity (Fig 5.26) in the boreholes is predictably high (around $1 \cdot 10^{-7}$ m/s) in the upper part of the borehole before decreasing markedly at app-

Gi 2

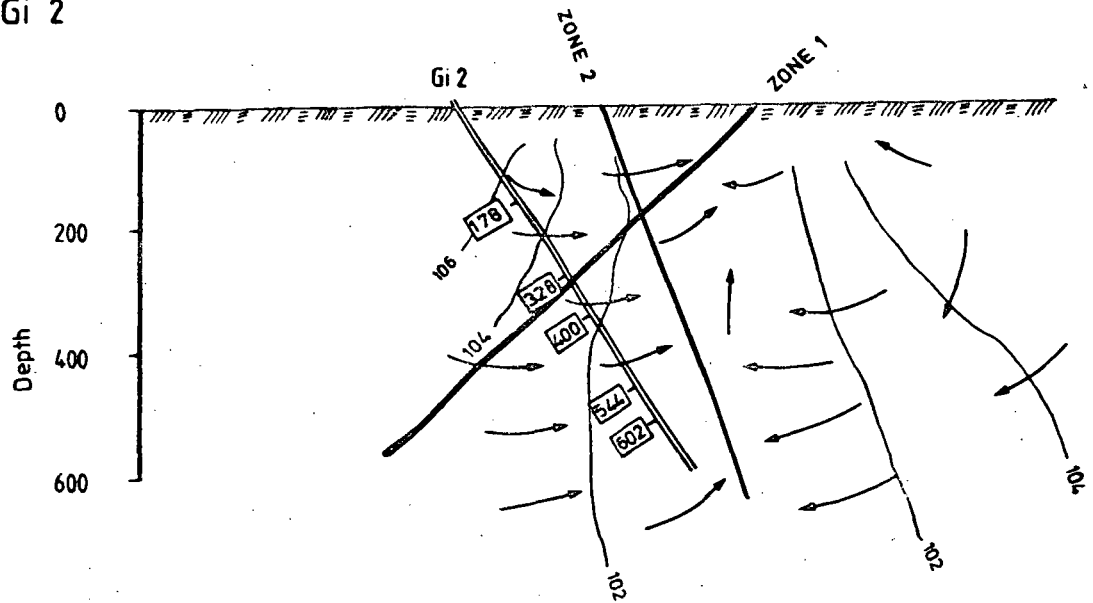

Figure 5.25: The groundwater flow-pattern and isopotentials in the vicinity of borehole Gi 2 illustrated by a vertical section in the same plane as the direction of the borehole (modified after the numerical modelling of the Kemakta Consulting Co).

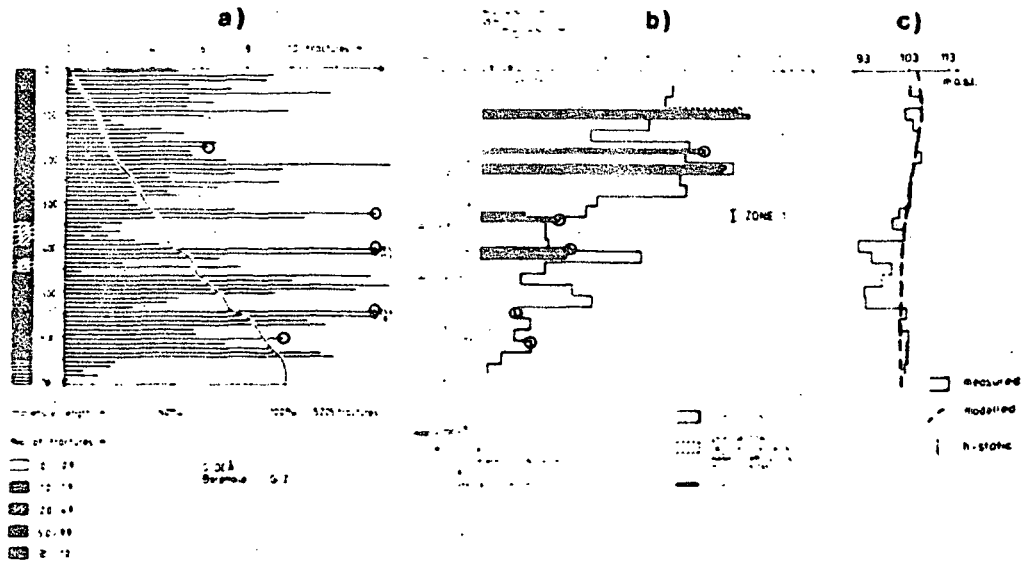

Figure 5.26: Hydrogeological characteristics of borehole Gi 2.

- a) Fracture frequency (for 10 m sections) and the cumulative percentage of fractures
- b) Hydraulic conductivity
- c) Piezometric head distributions and hydrostatic head in the borehole

Table 5.8a: Measured hydraulic parameters and calculated water budget values of the various influences due to borehole activities at the water sampled levels in borehole G1 Z.

Level	K-value*	Head deviation*	Flow direction (borehole trends)	Drilling water (+)	Cas-lift pumping(-)	Hydraulic testing (+)	Open hole effect before sampling(+)	Sampled water before analysis (-)
(m hole length)	(m/s)	(m)		(m ³)	(m ³)	(m ³)	(m ³)	(m ³)
178-180	1.3·10 ⁻⁷	+1.6	↑	0.61	0.15	0.055	-8.5	7.7
328-330	8.6·10 ⁻¹¹	-3.5	→	0.004	<0.001	<0.001	0.015	2.6
400-402	1.0·10 ⁻¹⁰	-11.0	→	0.004	<0.001	<0.001	0.055	2.3
544-546	2.1·10 ⁻¹¹	-0.5	→	<0.001	<0.001	<0.001	0.001	2.0
602-604	4.5·10 ⁻¹¹	-0.4	→	<0.001	<0.001	<0.001	0.001	3.5

* 25 m section; head deviation from hydrostatic head in the borehole (in metre of water).

Table 5.8b: Geo physicochemical parameters of groundwater sampled from the G&B Test-site area, Et. Sweden.

DEPTH BELOW SURFACE (meters)	TEMPERATURE (°C)	pH	CONDUCTIVITY (µmhos/cm)	Ca ²⁺ (mg/l)	Mg ²⁺ (mg/l)	Na ⁺ (mg/l)	Cl ⁻ (mg/l)	SO ₄ ²⁻ (mg/l)	NO ₃ ⁻ (mg/l)	CO ₃ ²⁻ (mg/l)	HCO ₃ ⁻ (mg/l)	SiO ₂ (mg/l)	Fe (µg/l)	Mn (µg/l)	Zn (µg/l)	Cu (µg/l)	Activity Ratio
178	10.5	7.2	120	1.2	0.8	0.5	1.5	1.0	0.5	0.2	0.3	0.1	0.1	0.1	0.1	0.1	0.1
328	10.5	7.2	120	1.2	0.8	0.5	1.5	1.0	0.5	0.2	0.3	0.1	0.1	0.1	0.1	0.1	0.1
400	10.5	7.2	120	1.2	0.8	0.5	1.5	1.0	0.5	0.2	0.3	0.1	0.1	0.1	0.1	0.1	0.1
544	10.5	7.2	120	1.2	0.8	0.5	1.5	1.0	0.5	0.2	0.3	0.1	0.1	0.1	0.1	0.1	0.1
602	10.5	7.2	120	1.2	0.8	0.5	1.5	1.0	0.5	0.2	0.3	0.1	0.1	0.1	0.1	0.1	0.1

NOTE: These analyses represent samples taken towards the end of each sampling period. The reported values should therefore be the best representation for the groundwater at the depth of investigation.

- 1) Conductivity (TCU) = the number of tri-ionic atoms per 10⁶ molecules water.
- 2) Laboratory values.
- 3) Samples considered suitably representative.

rox. 300 m; only around 400 m does the conductivity temporarily increase to 1.10⁻⁹ m/s.

5.2.1.1 Level 178 - 180 m (approx. 157 m)

The sampled level is located within a section comprising 3 different rock types. The dominant rock is the veined migmatite gneiss which is traversed by a coarse pegmatite (approx. 50 cm thick); a small thickness of granite gneiss constitutes the lower part of the section. The frequency of fracture zones is high ranging in width from 10 to 30 cm; a 30 cm wide crush zone (50 fractures/metre) is also present. These fractures intersect the axis of

the core at angles ranging from 20° to 90° and the infilling mineral phases include chlorite, calcite, epidote, pyrite and laumontite. The main concentration of fractures occurs at the lower part of the section where the contacts between the veined gneiss/ pegmatite/ granite gneiss are present.

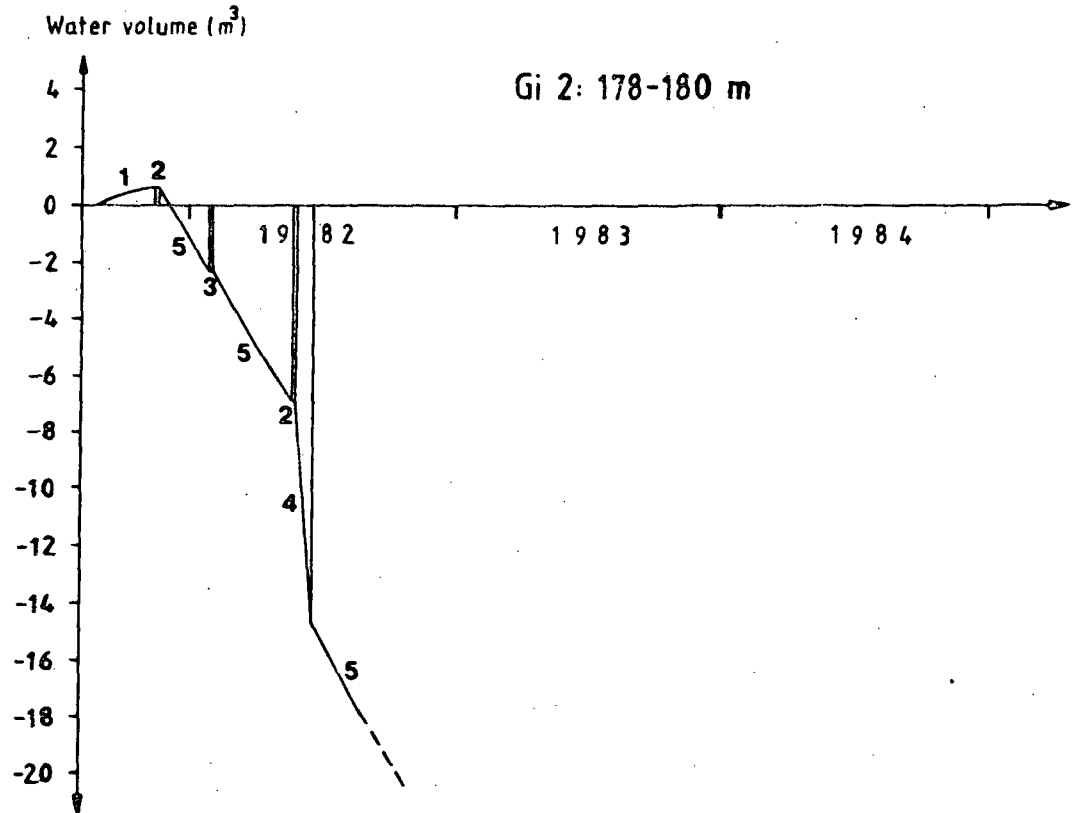

Figure 5.27: Schematic illustration of the calculated water budget for level 178-180 m in borehole Gi 2 (Gideå). 1 = Drilling water; 2 = Gas-lift pumping; 3 = Hydraulic testing; 4 = Sampling; 5 = Open-hole effect.

Hydrology

The water injection tests conducted along 25 m and 10 m sections of the borehole indicate that the sampled section coincides with a water-conducting horizon. From the 25 m section a hydraulic conductivity of $1.3 \cdot 10^{-7}$ m/s was calculated which is considered normal for this depth. The piezometric head is determined to 1.6 m above hydrostatic head in the borehole; the 10 m section measurement doubles this value. Overall, these hydraulic characteristics result in a water budget (Fig 5.27) which gives good reason to believe that a representative groundwater sample should be possible from this level.

Water geochemistry

The sampled groundwater (Table 5.8b) is characterised by a pH of 8.8 and normal amounts of the major cations Na^+ and Ca^{2+} and anions HCO_3^- and Cl^- that would be expected for non-saline groundwaters in Swedish crystalline rocks (Table 5.1). Iodine is very low and probably represents background levels; this would infer minimal mixing with drilling waters.

Redox-sensitive parameters

Only low amounts of S(-II) and Fe(II) are present; an overall reducing environment is indicated by an Eh value of -90 mV and a general absence of oxygen.

Isotope geochemistry

The groundwater is characterised by $\delta^{18}\text{O}$ and $\delta^2\text{H}$ values of -12.62 ppt and -90.4 ppt respectively which indicate a meteoric origin (Fig 5.6); radiocarbon data are not available from this horizon. The background

tritium value (<3 TU) shows an absence of mixing with younger surface and near-surface waters.

Uranium geochemistry

Dissolved uranium contents by both methods give low values (0.20 - 0.23 ppb); the $^{234}\text{U}/^{238}\text{U}$ activity ratio records a value of 7.7 which indicates widespread disequilibrium in the groundwater.

Summary

The results show that the sampled horizon is characterised by groundwaters which appear to be representative for shallow groundwaters of a mildly reducing character. There is no indication that drilling water or younger more surficial water are present in significant quantities. This is supported by the hydrological data which recorded a positive piezometric head and reasonable hydraulic conductivity for this horizon. From the water budget calculations the small amount of drilling water introduced into the bedrock was quickly removed by open-hole effects as determined by the bedrock hydrology. No significant variation in the physico-chemical parameters of the water during the sampling period were observed.

5.2.1.2 Level 328 - 330 m (approx. 288 m)

The bedrock present within the sampled section length represents the contact between brecciated veined gneiss and pegmatite. The section is thus highly fractured and contains three crush zones varying in width from 2 to 17 cm. Single fractures and composite fracture zones (10-15 cm wide and containing 4 and 6 fractures respectively) constitute the remaining portion of the section. The fractures intersect the axis of the core at angles

varying from 40° to 90° and the dominant infilling minerals include laumontite, calcite, chlorite, and muscovite; the fractures are commonly weathered. The fracturing exposed along this section forms part of the much larger local fracture Zone 1 which extends from 309-335 m.

Hydrology

The hydraulic conductivity of fracture Zone 1 is estimated to be $6.5 \cdot 10^{-10}$ m/s. Although the conductivity across the total width of the Zone has not been measured in detail, it is clear that the sampled section is located in a relatively conductive part. The hydraulic head determined from the 25 m section test is calculated to -3.5 metre of water and to -1.6 m using measurements along a 10 m section. The hydraulic characteristics and the calculated water budget values compiled in Table 5.8 imply that the influence from the borehole activities are very small. The movement of groundwater in the borehole due to open-hole effects is downwards (almost certainly in part from the higher sampled level at 178-180 m), and enters the sampled horizon whereupon it is quickly removed during gas-lift pumping and pumping prior to sampling. The water sample should therefore be representative and uncontaminated.

Water geochemistry

The sampled groundwater has a pH of 8.8; of the major cations (Na^+ and Ca^{2+}) and anions (HCO_3^- and Cl^-) there are no differences from the previous higher level and the water shows no significant drilling water component (0.2 % I^-).

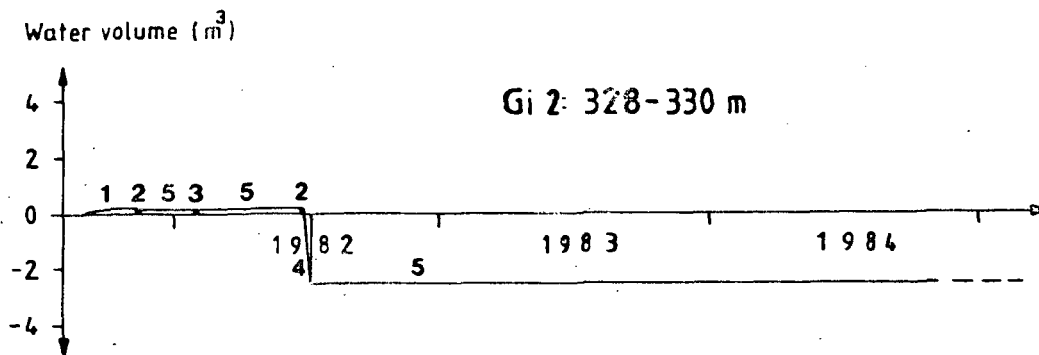

Figure 5.28: Schematic illustration of the calculated water budget for level 328-330 m in borehole Gi 2 (Gideå). 1 = Drilling water; 2 = Gas-lift pumping; 3 = Hydraulic testing; 4 = Sampling; 5 = Open-hole effect.

Redox-sensitive parameters

In comparison with the higher sampled level only Fe(II) shows an increase to 0.59 mg/l; S(-II) is similarly low and no oxygen was recorded. A moderately reducing environment is indicated by a Eh value of -60 mV.

Isotope geochemistry

A meteoric origin is indicated by the $\delta^{18}\text{O}$ and $\delta^2\text{H}$ values of -12.57 ppt and -90.1 ppt respectively. The radiocarbon data recorded an age of 6445 years; this together with background tritium values (<3 TU) show that there is no major young water component involved.

Uranium geochemistry

The dissolved uranium content ranges from 0.12 - 1.13 ppb and the $^{234}\text{U}/^{238}\text{U}$ activity ratio is 5.4 which denotes widespread disequilibrium in the groundwaters.

Summary

The general chemistry of the groundwater from this level differs little from the preceding horizon. The representative groundwater predicted by hydrological considerations seems to be borne out by the various chemical parameters. There is no evidence of significant mixing with younger, more surface-derived waters, nor with drilling water. The waters, in common with the previous higher level, appear to be representative of shallow to intermediate groundwaters of a moderately reducing character.

No significant variation in the physico-chemical parameters of the water during the sampling period were observed.

5.2.1.3 Level 400 - 402 m (approx. 353 m)

The rock-type characterising this section is a red, twomica granite, strongly crushed and fractured. Four crush zones are in evidence ranging in width from 10 - 25 cm; single fractures and 2 fracture zones (up to 5 cm in width and containing 3 fractures) comprise the remainder of the drillcore section. These fractures intersect the axis of the core at angles varying from 10° - 80° ; the main infilling mineral phases are calcite and chlorite with subordinate laumontite and fluorite.

Hydrology

From the water injections tests it was indicated that the sampled level formed part of a measured 10 m section which conducted all of the water from within the initially measured 25 m section. The hydraulic conductivity of the 10 m section is $2.5 \cdot 10^{-10}$ m/s and is thus assumed to be representative for the sampled horizon. As a result the water budget values are somewhat

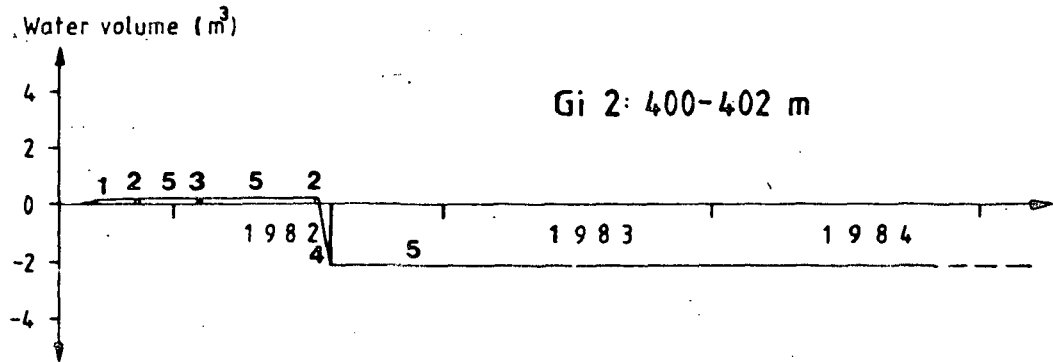

Figure 5.29: Schematic illustration of the calculated water budget for level 400-402 m in borehole Gi 2 (Gideå). 1 = Drilling water; 2 = Gas-lift pumping; 3 = Hydraulic testing; 4 = Sampling; 5 = Open-hole effect.

greater than those presented in Table 5.8a, which are calculated from the 25 m sections. However, this does not change the general overall picture illustrated in Figure 5.29 which shows that contaminating waters introduced along the fracture zone, i.e. drilling water and water resulting from hydraulic testing and open-hole effects, are rapidly removed during gas-lift pumping and pumping just prior to sampling. The waters should therefore be uncontaminated and representative for the sampled level.

Water geochemistry

The pH of the sampled water is 8.6; in common with the upper two levels the contents of Na^+ , Ca^{2+} , HCO_3^- and Cl^- are normal and representative for non-saline groundwaters. The very low I^- content (0.4 %) indicates little of drilling water contamination.

Redox-sensitive parameters

S(-II) and Fe(II) are still present in low amounts (0.04 and 0.41 mg/l respectively); a higher Eh value (-40 mV) is obtained than the two preceding levels although the O_2 content is still low (0.1 mg/l).

Isotope geochemistry

The $\delta^{18}O$ value of -12.68 ppt and the δ^2H value of -91.4 ppt supports a meteoric origin to the water. The ^{14}C age of 6570 years is close to the last level described; this, together with background tritium values (<3 TU), indicate the absence of a younger, near-surface water component.

Uranium geochemistry

Only a single value for the total dissolved uranium is available. This is low (0.27 ppb) and supports a generally reducing environment; no activity ratio value is available.

Summary

Water budget estimations from 10 m and 25 m sections suggest that the introduction of contaminating water into the fracture zone was minimal and was quickly removed during gas-lift pumping and pumping just prior to sampling. This is supported by the chemical parameters which point to a moderately reducing shallow to intermediate groundwater with an absence of drilling water contamination and groundwater mixing from younger, surface and near-surface sources.

No significant variation in the physico-chemical parameters of the water during the sampling period were observed.

5.2.1.4 Level 544-546 m (approx. 478 m)

The section chosen for sampling is contained within a heavily crushed chloritised dolerite dyke. Fracturing along the section consists of a crush zone (20 cm wide), three fracture zones varying in width from 2 to 12 cm, and a single fracture; the intersection angles with the axis of the core range from 10° to 90° . The dominant fracture filling minerals are chlorite, epidote and calcite.

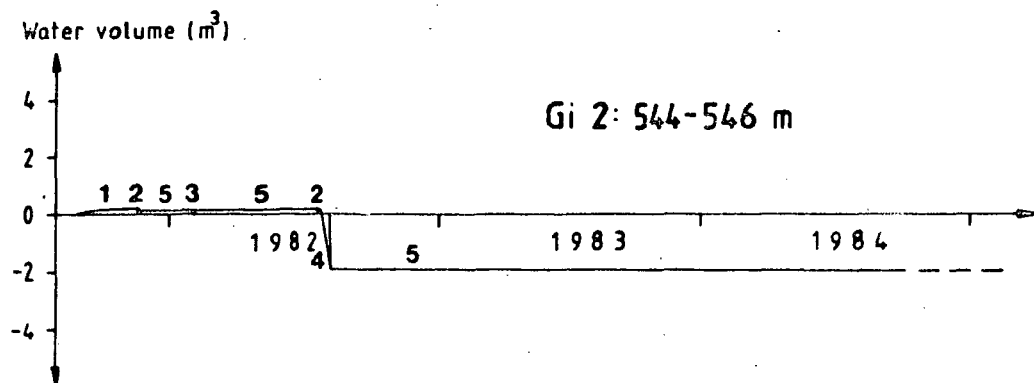

Figure 5.30: Schematic illustration of the calculated water budget for level 544-546 m in borehole Gi 2 (Gideå). 1 = Drilling water; 2 = Gas-lift pumping; 3 = Hydraulic testing; 4 = Sampling; 5 = Open-hole effect.

Hydrology

Based on measurements carried out along 25 m sections, the hydraulic conductivity ($K = 2.1 \cdot 10^{-11}$ m/s) and the piezometric head deviation (i.e. -0.5 m) are quite small (Table 5.8a). This means that the potential extent of groundwater contamination during drilling and injection testing is minimal and should be easily removed prior to sampling (Fig 5.30). A downward transport of groundwater along the borehole is also indicated at this depth.

Water geochemistry

A pH of 8.8 and normal non-saline groundwater amounts of Na^+ , Ca^{2+} , HCO_3^- and Cl^- characterise the groundwater from this level (Table 5.8b). The low background amounts of I^- (0.4 %) indicate the absence of a significant drilling water component.

Redox-sensitive parameters

The S(-II) and Fe(II) values are low (0.2 and 0.78 mg/l respectively); the slightly higher Fe(II) value compared with the preceding three levels may be a local influence from the dolerite. A more negative Eh value (-90 mV) and an absence of O_2 might suggest a more reducing groundwater than the previous two levels.

Isotope geochemistry

A meteoric origin to the groundwater is indicated by the $\delta^{18}\text{O}$ and $\delta^2\text{H}$ values which record respectively -12.44 ppt and -89.5 ppt (Fig 5.6). The radiocarbon data indicate an age of 6720 years for the groundwater; this, together with background tritium values (<3 TU), indicate the absence of a younger near-surface component.

Uranium geochemistry

Low uranium amounts are also maintained at this level (0.31 ppb); supplementary uranium and $^{234}\text{U}/^{238}\text{U}$ activity ratio data are not available.

Summary

From the hydrological and water budget considerations this sampled zone should be characterised by a minimum of contamination either from drilling water or from injection testing and open-hole effects. From the various chemical parameters measured this would appear to the case, with an absence of drilling water tracer and of a younger, near-surface water component. The sampled waters are typical of shallow to intermediate groundwaters. No significant variation in the physico-chemical parameters of the water during the sampling period was observed.

5.2.1.5 Level 602 - 604 m (approx. 528 m)

The bedrock section chosen for sampling represents the contact between a fine-grained chloritised dolerite and the dominant migmatitic veined gneiss. The core section is markedly tectonised resulting in two crushed portions (4 and 20 cm wide), one major fracture zone (10 cm wide and containing 10 fractures), and one single fracture. The angle of fracture intersection with the axis of the core ranges from 5° to 90° ; the main fracture filling mineral phases include chlorite, laumontite and pyrite with some evidence of iron oxide staining on the fracture interfaces.

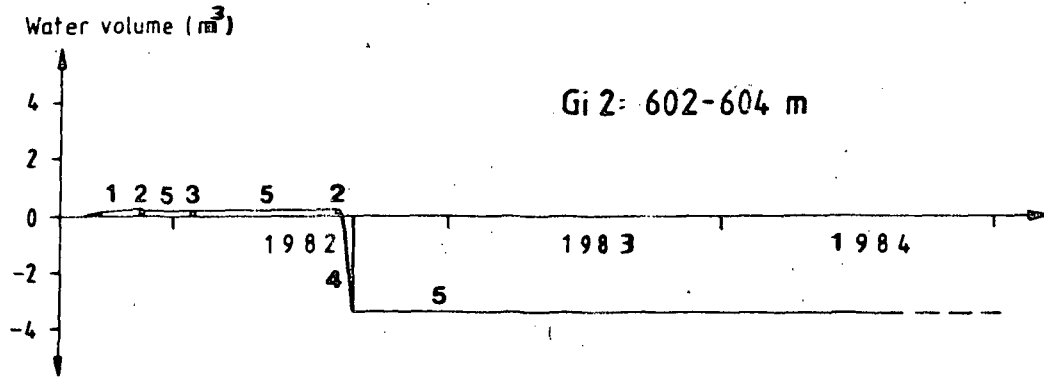

Figure 5.31: Schematic illustration of the calculated water budget for level 602-604 m in borehole Gi 2 (Gideå). 1 = Drilling water; 2 = Gas-lift pumping; 3 = Hydraulic testing; 4 = Sampling; 5 = Open-hole effect.

Hydrology

A combination of a low hydraulic conductivity ($K = 4.5 \cdot 10^{-11}$ m/s) and a small negative head deviation (-0.4 m) make this level similar to the previous one.

Water geochemistry

Essentially similar to the previous level (Table 5.8b).

Redox-sensitive parameters

Essentially similar to the previous level.

Isotope geochemistry

Essentially similar to the previous level.

Uranium geochemistry

More information is available from this level. The dissolved uranium content is low ranging from 0.06 to 0.15 ppb and the activity ratio is 5.9 which is high and indicates extensive isotopic disequilibrium in the groundwater.

Summary

There are no significant differences in the hydrological and chemical properties of the groundwater sampled from this level when compared with the previous level. In addition, there was no variation in the physico-chemical properties of the water during the sampling period.

5.2.1.6 Borehole summary and discussion

Based on geological considerations and hydrogeological investigations carried out along 25 m sections of the borehole (in some cases more detailed measurements were conducted along 10 m lengths) five suitably conducting fracture zones were selected for groundwater sampling purposes. It should be noted, however, that four of the levels record hydraulic conductivity values which are lower than $1 \cdot 10^{-10}$ m/s. One of the sampled levels (328 - 330 m) represents the intersection of the borehole with local fracture Zone 1 which is thought to extend to the bedrock surface. All the selected fracture horizons are markedly fractured; this is usually apparent as crush zones, fracture zone and individual fractures of varying widths and orientations. The dominating fracture infilling phases are chlorite and pyrite with subordinate amounts of laumontite; epidote tends to occur within the dolerite and muscovite within the more granite/pegmatite rock types. Red staining due to iron-oxide disseminations is sporadic.

The natural groundwater flow in the near-vicinity of the borehole is generally downwards and directed towards fracture Zone 2 (Fig 5.24).

At the uppermost level a positive piezometric head exists which contrasts with the remaining four levels which show negative values along the measured 25 m sections. In general, the water budget calculations suggest that at all levels, in particular the uppermost horizon, the sampled groundwaters should be representative of the respective depths sampled i.e. devoid of residual water from borehole activities and from other sources within the surrounding bedrock. Because of the very fractured nature of the bedrock, the chosen water conducting levels are reasonably representative for the hydrologic parameters measured.

Considering the fractured nature of the bedrock and the variation in depth of the groundwater samples, it is remarkable to note the homogeneity of the groundwater chemistry from all sampled horizons. In general, the groundwaters can be considered shallow to intermediate in origin exhibiting a pH of 8.6 to 8.9 and a major ion content indicative of non-saline groundwaters common to Swedish crystalline bedrock environments. Residual drilling water is generally absent and the isotopic data show that no younger, surface or near-surface component is present. The radiocarbon ages are uniform (6435-6720 years) and the stable isotope data suggest a meteoric origin to the waters. The measured redox parameters indicate a low to moderately reducing environment (Eh is -40 to -90 mV); O_2 is on the whole absent and dissolved uranium contents are uniformly low (0.06 to 1.34 ppb). The $^{234}U/^{238}U$ are anomalously high (5.4 to 7.7) which indicates widespread disequilibrium in the groundwaters. The high values also suggest that the groundwaters have had long residence times in contact with the fracture zone interfaces allowing alpha recoil processes to make a significant contribution to the

excess ²³⁴U. The unusually low Fe(II) and S(-II) contents may reflect the moderately reducing nature of the groundwaters.

As we have seen from the hydrological considerations, the uppermost level is characterised by a positive head and reasonable conductivity in comparison with the deeper levels. Open-hole effects will then be dominated by water entering the borehole at the uppermost level; groundwater sampled from this horizon will therefore be representative. However, the combination of a negative head and low conductivity values for the four deeper horizons will result in an partial vacuum being produced within the individual sections being sampled thus encouraging borehole water to be pumped into the section via an interconnecting network of fractures or between the packers and the borehole walls. The water sampled from these horizons will therefore be dominated by borehole water which has its source in the uppermost level. This would account for the observed uniformity of all chemical parameters measured, and would explain why all the sampled waters can be classified as being shallow to intermediate in origin. Only the uppermost level can be considered representative; the groundwater characteristics of the deeper groundwaters are still unknown.

The uranium contents of the sampled groundwaters from borehole G1 2 are mostly low (0.06 - 0.31 ppb) with the exception of one analysis from level G1 2 which recorded 1.34 ppb. There is no obvious systematic decrease of content with depth, but the lowest values (0.06 - 0.15 ppb) correspond with the deepest level (602 m). The lack of any systematic variation is in accord with most of the chemical parameters measured from this hole. The analytical contents, together with the theoretical Eh values calculated for the iron system, are presented in Table 5.9 and Figure 5.32. The figure also contains theoretical uranium solubility curves calculated from crystalline and amorphous UO₂ for a pH of 9.50 which is

reasonably representative for the waters from borehole Gi 2. All five water compositions plot within or just outside the calculated uranium solubility boundaries.

Table 5.9: Uranium content and theoretical Eh values of the groundwater from borehole Gi 2

Level (metres)	Uranium Content (ppb)	Calculated Eh (mV)
178-180	0.20	-218
328-330	1.34	-256
400-402	0.27	-236
544-546	0.31	-280
602-604	0.15	-207

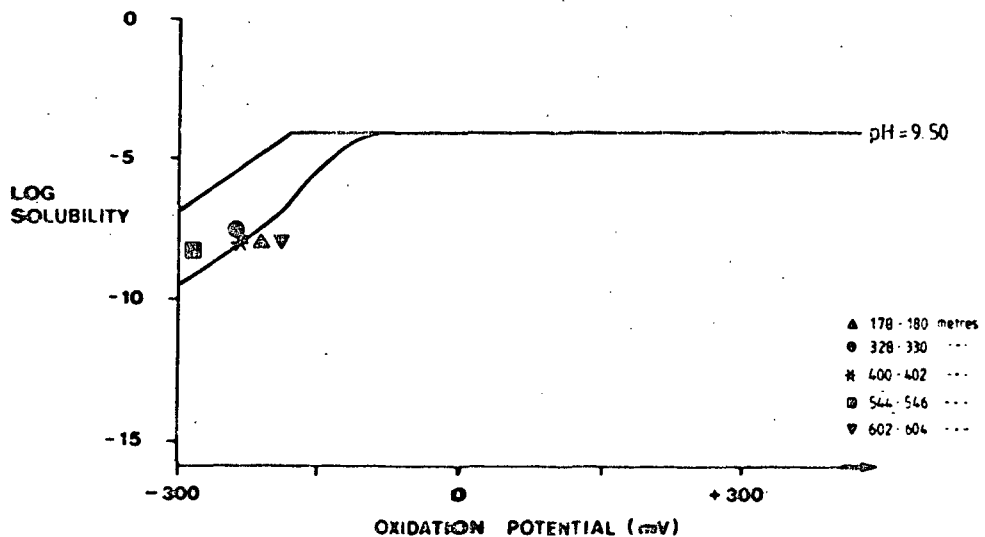

Figure 5.32: Plots of uranium content (expressed as log (mol/litre)) and the calculated theoretical Eh values of groundwaters collected from borehole Gi 2. The values are plotted with respect to theoretical uranium solubility curves calculated for amorphous (lower stability limit) and crystalline (upper stability limit) UO_2 at a pH of 9.50.

5.2.2 Borehole Gi 4

Borehole Gi 4 was drilled at 70° to a vertical depth of 543 m (borehole length 692 m) to investigate at depth local fracture Zone 4 which could be detected topographically and geophysically in a east-west orientation just to the north of the drilling site (Fig 5.24). In addition, the area is characterised by a magnetic anomaly which could indicate subsurface structures of interest. Drilling of the borehole encountered three main structural zones of weakness in addition to several more minor zones of increased fracture frequency. The initial 250 m was representative of near horizontal tensional fracturing due to the removal of the ice burden during Pleistocene times. Between 217 - 259 m fracture Zone 3A was traversed and Zone 4 between 606 - 655 m; Zone 6 was intercepted at 670 - 690 m (Fig 5.24).

The dominant rock type is veined migmatite gneiss (93.3 length %) with subordinate intercalations of granite gneiss (4.0 length %) and pegmatite (2.7 length %); no dolerite dykes were intercepted by drilling. The granite gneiss varied in thickness from 0.5 to 8.4 m with an average thickness of 1.96 m, and the pegmatite ranged from 0.2 to 5.5 m with an average thickness of 0.88 m. The average number of fractures/metre is less than Gi 2 (i.e. 5.12 compared to 7.37) with the pegmatite being least fractured (4.35 fractures/metre) followed by migmatite gneiss (5.05) and lastly the granite gneiss (7.05). The greatest concentration of fractures (apart from the upper 200 - 250 m) occurs between 600 - 700 m which represents the intersection of the borehole with Zones 4 and 6. Within the major crush zones the most common fracture filling minerals are chlorite, calcite and laumontite.

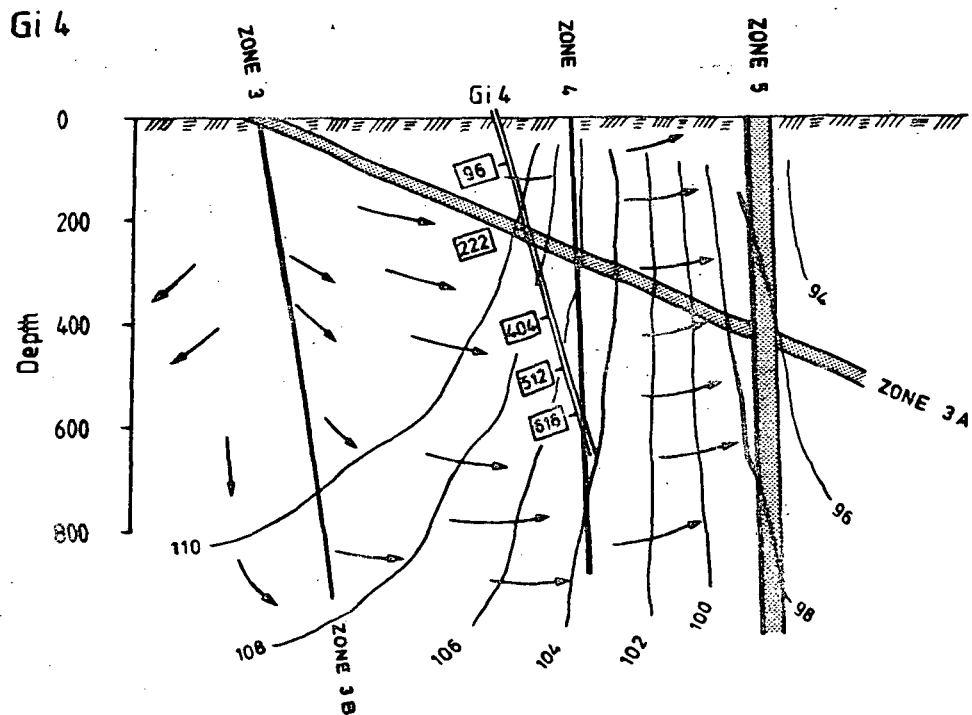

Figure 5.33: The groundwater flow-pattern and isopotentials in the vicinity of borehole Gi 4 illustrated by a vertical section in the same plane as the direction of the borehole (modified after the numerical modelling of Kemakta Consulting Co).

The presence of three major structural zones of weakness and their geometry have resulted in a very complex groundwater flow pattern around the borehole, too complex to be illustrated by the two-dimensional diagram shown in Figure 5.33. However, if one accepts that the considerable piezometric head is maintained to depth in the vicinity of Zones 3A and 3B, the high head gradients will result in a general groundwater flow directed towards Zone 5 and also along Zones 4 and 5 towards the east. Fracture Zones 3A and 3B thus facilitate fast transport of groundwater to depth and it would therefore be expected to find a younger water at greater depths here than elsewhere.

The hydraulic conductivity along the borehole is variable with sections of high conductivity separated by relatively impermeable rock sections (Fig 5.34b). The three intercepted fracture Zones 3A, 4 and 6 have an estimated hydraulic conductivity of 2.10^{-7} m/s, 2.10^{-10} m/s and $<5.10^{-12}$ m/s respectively. According to the numerical modelling of Carlsson et al (1983) the piezometric head decreases almost linearly from 114 m above sea-level to 104 m at the bottom of the hole. The results from the injection tests diverge significantly from this, especially below 200 m. The few piezometric head measurements available between 300 - 500 m indicate a much lower head, which at greater depths increases and even becomes positive implying an upward groundwater flow.

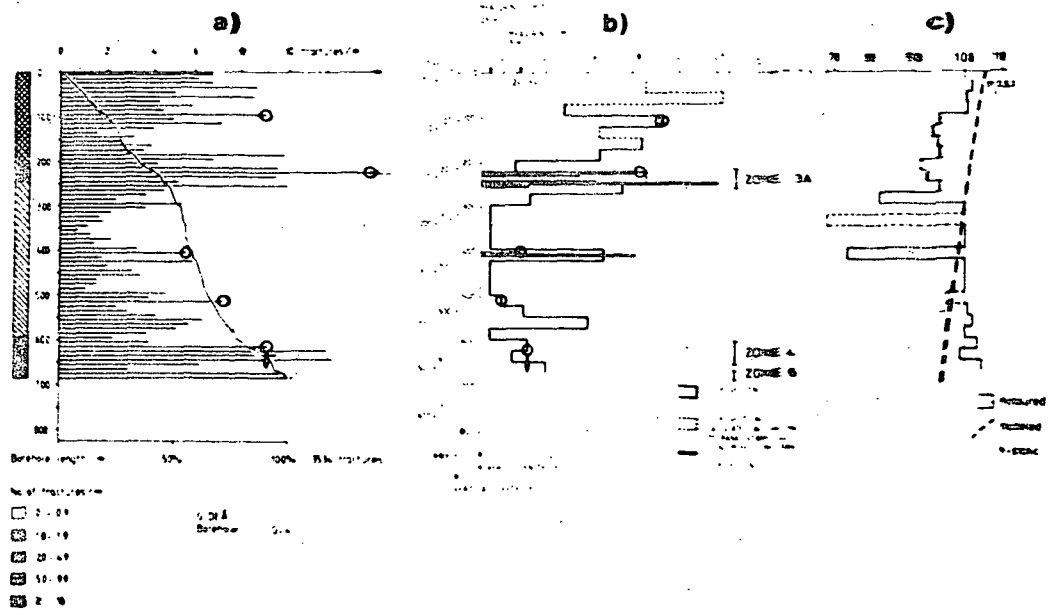

Figure 5.34: Hydrogeological characteristics of borehole G1 4.

- a) Fracture frequency (for 10 m sections) and the cumulative percentage of fractures
- b) Hydraulic conductivity
- c) Piezometric head distributions and hydrostatic head in the borehole

Table 5.10a: Measured hydraulic parameters and calculated water budget values of the various influences due to borehole activities at the water sampled levels in borehole G1-4.

Level	K-value*	Head deviation*	Flow direction (borehole trends)	Drilling water (+)	Gas-lift pumping(-)	Hydraulic testing(+)	Open hole effect before sampling(±)	Sampled water before analysis (-)
(m hole length)	(m/s)	(m)		(m ³)	(m ³)	(m ³)	(m ³)	(m ³)
96-98	4.4·10 ⁻⁸	-5.1	+	1.50	0.108	0.018	8.0	2.7
222-224	2.1·10 ⁻⁸	-7.3	+	0.82	0.053	0.004	5.9	1.3
404-406	2.3·10 ⁻⁹	-26.6	+	0.076	0.005	0.002	2.6	2.2
512-514	9.5·10 ⁻¹²	-3.5	+	<0.001	<0.001	<0.001	0.002	3.2
616-	1.10 ⁻¹⁰ **	+4.0	+	0.207	<0.001	<0.001	-1.13	0.07

* 25 m section; head deviation from hydrostatic head in the borehole (in metre of water).

** Average of three 25 m sections

Table 5.10b: Some geochemical parameters of granoblasts sampled from the G1/G2-1000 area in Sweden.

DEPTH BELOW SURFACE (metres)	DEPTH (cm)	SPOT NO.	ANALYSES	SiO ₂ (%)	TiO ₂ (%)	Al ₂ O ₃ (%)	FeO (%)	MnO (%)	MgO (%)	CaO (%)	Na ₂ O (%)	K ₂ O (%)	H ₂ O (%)	CO ₂ (%)	Loss on ignition (%)	Activity index
100	100	10	10	65.5	0.1	15.2	1.5	0.1	1.2	0.1	0.1	0.1	0.1	0.1	0.1	0.1
100	100	11	11	65.5	0.1	15.2	1.5	0.1	1.2	0.1	0.1	0.1	0.1	0.1	0.1	0.1
100	100	12	12	65.5	0.1	15.2	1.5	0.1	1.2	0.1	0.1	0.1	0.1	0.1	0.1	0.1
100	100	13	13	65.5	0.1	15.2	1.5	0.1	1.2	0.1	0.1	0.1	0.1	0.1	0.1	0.1
100	100	14	14	65.5	0.1	15.2	1.5	0.1	1.2	0.1	0.1	0.1	0.1	0.1	0.1	0.1

1) These analyses represent samples from towards the end of each sampling line (and the reported values should therefore be the most representative for the granuloblasts at the depth of investigation).

2) 100 analyses (10) = the number of mineral grains per 1² centimetre area.

3) Laboratory values.

* Sample considered suitable representative

5.2.2.1 Level 96 - 98 m (approx. 91 m)

The section chosen for sampling represents the contact between veined migmatite gneiss and a grey medium-grained granite. The core is not heavily fractured but contains some 15 single fractures and one narrow fracture zone (2 cm in width) comprising 3 fractures. The intersection angle of the fractures with the axis of the core ranges from 20° to 90°. The main infilling mineral phases are calcite with subordinate pyrite and muscovite.

Hydrology

The hydraulic conductivity of $4.4 \cdot 10^{-8}$ m/s recorded for this level is a moderate value for such a bedrock depth. From the water budget calculations (Table 5.10a, Fig 5.35) by far the greatest influence on the groundwater conditions is caused by open-hole effects due to the hydraulic head being some 5 m below hydrostatic head in the borehole. This will result in drilling water contamination being drawn far into the fracture zone together with the water in the borehole which probably originates from higher, near-surface levels. It is therefore highly unlikely that gas-lift pumping and pumping just prior to sampling will have any marked effect on removing the contaminated water. From hydrological considerations this groundwater should not be representative.

Water geochemistry

The sampled water (Table 5.10b) records a pH of 7.9; the major ions Na^+ and Ca^{2+} are respectively somewhat lower and higher, and Cl^- somewhat lower than normal shallow to intermediate groundwaters encountered so far in borehole Gi 2. This would suggest waters from a near-surface horizon. A I^- content of 0.5 % indicates some contamination from drilling fluid.

Redox-sensitive parameters

An Eh value of +10 mV indicates an oxidising groundwater environment. This is to some extent supported by low to negligible amounts of Fe(II) and S(-II); in this context the presence of only 0.04 mg/l of oxygen is rather surprising.

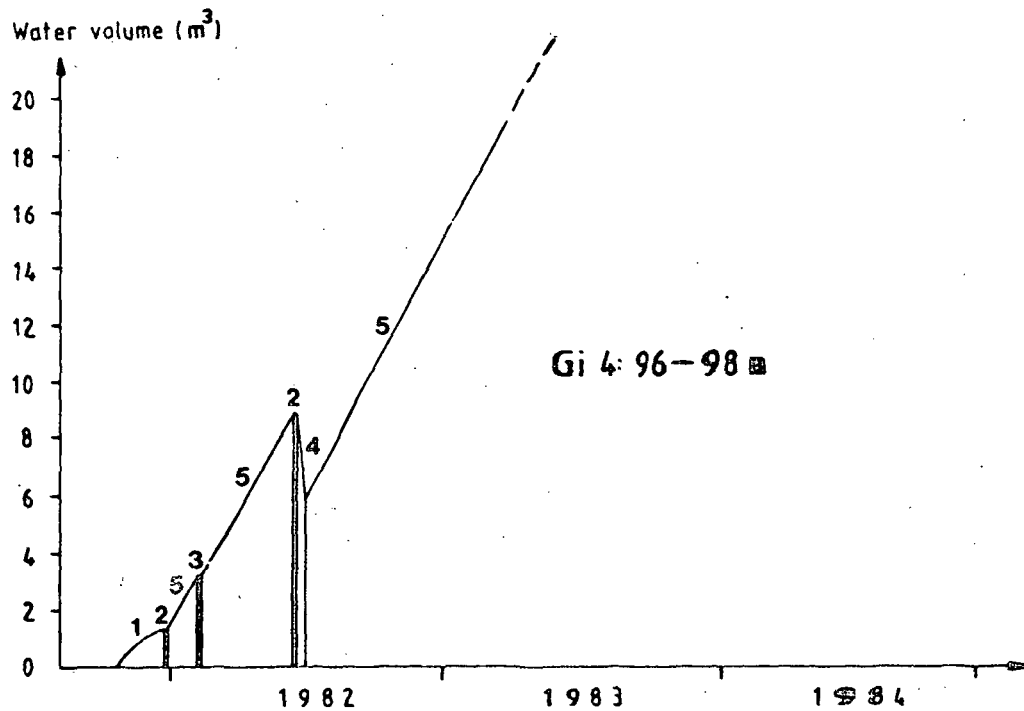

Figure 5.35: Schematic illustration of the calculated budget for level 96 - 98 m in borehole Gi 4 (Gideå). 1 = Drilling water; 2 = Gas-lift pumping; 3 = Hydraulic testing; 4 = Sampling; 5 = Open-hole effect.

Isotope geochemistry

Stable isotope values of $\delta^{18}\text{O} = -12.93$ ppt and $\delta^2\text{H} = -93.4$ ppt indicate a meteoric origin to the water (Fig 5.6). The very high tritium value of 36 TU supports the significant young water component suggested by the general chemical characteristics above; no radiocarbon data are available.

Uranium geochemistry

Only one uranium value is available (1.02 ppb) suggesting a marginally oxidising environment; no isotope data exist.

Summary

The chemical parameters of the water sample indicate that a major portion is derived from young near-surface sources; a smaller percentage is from the drilling water source. It is thus reasonable to assume, as predicted by the hydrological data, that the sampled groundwater is not representative for this level, and that it has mostly originated from higher more oxidising levels in the bedrock.

5.2.2.2 Level 222 - 224 m (approx. 212 m)

The sampled section is composed of a single rock-type, a light-grey, medium-grained granite; contact with the veined migmatite gneiss occurs just below the section. The core length comprises numerous fracture zones ranging in width from 2 to 16 cm (containing 3 to 20 fractures); 3-4 single fractures and a narrow crush zone (3 cm wide) constitute the remainder. These fractures represent part of local fracture Zone 3A which extends from 217 - 259 m. The angle of intersection of the fractures with the core axis varied from 10° to 80° and the main infilling minerals are calcite with subordinate chlorite.

Hydrology

Because the sampled section is located marginally to fracture Zone 3A, it does not constitute the most conductive part. The hydraulic tests carried out along 25 m and 5 m length recorded a K-value of around 1.10^{-8} m/s. The low piezometric head (101 m above sea-level) emphasises the important influence open-hole effects will have on the waters sampled from this horizon (Fig 5.36). The water budget thus indicates that the groundwater sampled is not representative and probably originates from shallower levels; gas-lift pumping and pumping prior

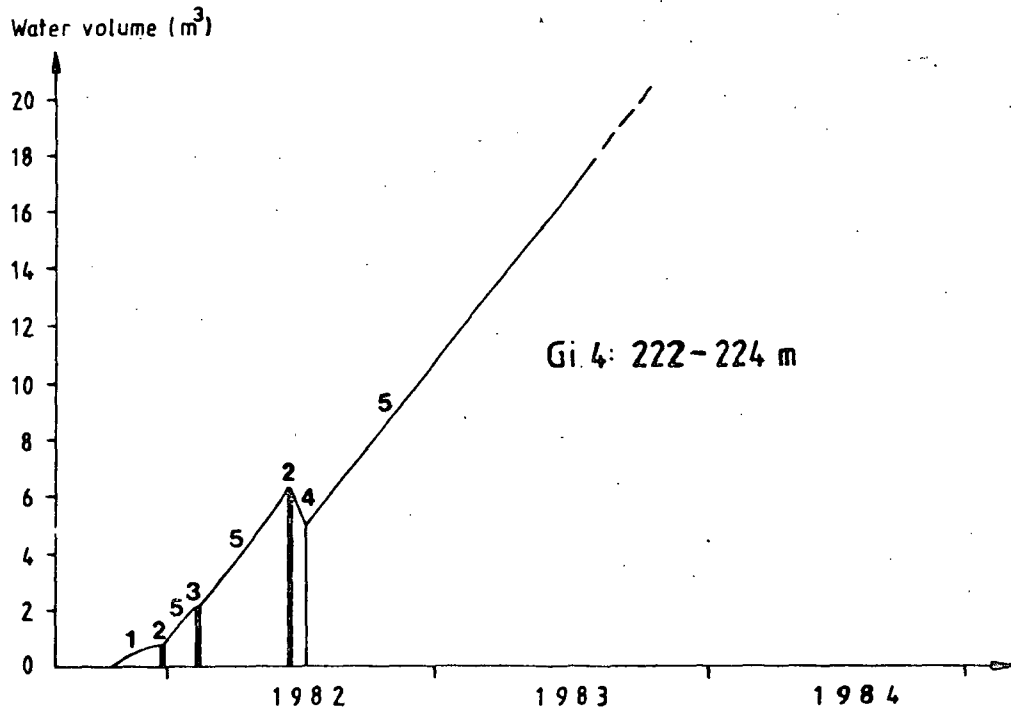

Figure 5.36: Schematic illustration of the calculated water budget for level 222 - 224 m in borehole Gi 4 (Gideå). 1 = Drilling water; 2 = Gas-lift pumping; 3 = Hydraulic testing; 4 = Sampling; 5 = Open-hole effect.

to sampling is inadequate to remove such contamination, which will also include a drilling water component.

Water geochemistry

The sampled waters (Table 5.10b) have a pH of 9.0 and a major ion content (Na^+ , Ca^{2+} , HCO_3^- , Cl^-) more typical of non-saline groundwaters than the preceding level. The presence of 1.5 % I^- indicates a significant drilling water component as suggested by the water budget calculations.

Redox-sensitive parameters

An Eh value of -60 mV renders this water as being considerably more reducing than the previous level although only small amounts of Fe(II) and S(-II) are present; O_2 is more or less absent.

Isotope geochemistry

$\delta^{18}O$ and δ^2H values (-12.55 ppt and -89.7 ppt respectively) indicate a meteoric origin to the waters. A tritium value of 5 TU suggests only a small, younger near-surface component, which is essentially supported by the old radiocarbon age of 11895 years.

Uranium geochemistry

Dissolved uranium contents range from 0.67 to 0.98 ppb which support a general reducing environment. The $^{234}U/^{238}U$ activity ratio records a value of 6.7 which is high and indicates widespread disequilibrium in the groundwaters.

Summary

In contrast with the previous level this horizon from a chemical viewpoint is more representative for a shallow to intermediate groundwater environment. The hydrological data suggest that the water sampled should be from higher levels. This maybe so, but the lack of a significant younger water portion shows that the waters must be coming from a deeper level than those sampled from the previous horizon; drilling water, as shown by the I^- content, plays a part and this may account for the small amounts of tritium observed. This infers that perhaps the hydrological prediction is not quite valid for this

section, and that the sampled water may after all be reasonably representative for this depth, or alternatively, the groundwaters may be originating from a highly conductive zone at a greater depth than the previous section sampled, i.e. a more conductive part of the fracture Zone 3A positioned below the present horizon.

No significant variation in the physico-chemical parameters of the water during the sampling period were observed.

5.2.2.3 Level 404 - 406 m (approx. 385 m)

The chosen section is comprised of veined migmatite gneiss which are only moderately fractured. Apart from one fracture zone some 8 cm wide and containing 11 fractures, the remaining core is characterised by 10 to 12 single fractures. Angles of intersection between fracture and the core axis range from 30° to 90° , and the main infilling mineral phases consist of chlorite and laumontite with subsidiary calcite and pyrite.

Hydrology

The water budget calculations for this level, based on hydrological parameters measured along 25 m sections and illustrated in Figure 5.37, are not representative for the sampled horizon. Detailed injection tests performed have shown a much lower K-value for this horizon (below the limit of measurement) than the calculated values. It should therefore be impossible to obtain adequate groundwater from this rock section.

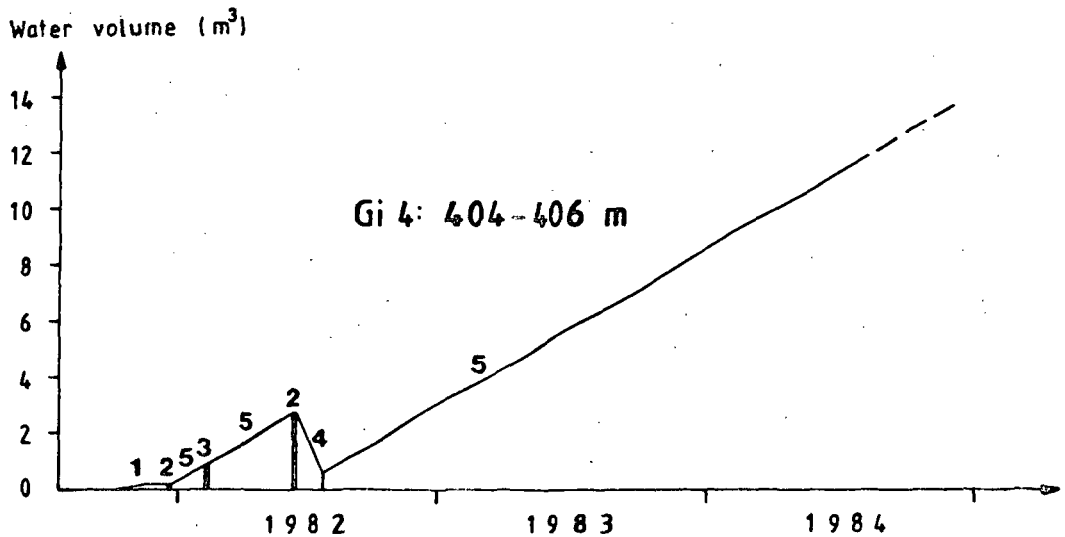

Figure 5.37: Schematic illustration of the calculated water budget for level 404-406 m in borehole Gi 4 (Gideå). 1 = Drilling water; 2 = Gas-lift pumping; 3 = Hydraulic testing; 4 = Sampling; 5 = Open-hole effect.

Water geochemistry

The sampled water has a pH of 9.3; compared with non-saline crystalline bedrock groundwaters the major cations Na^+ and Ca^{2+} are respectively higher and lower than would be expected, and the anions HCO_3^- and Cl^- are respectively lower and higher. The groundwater is therefore saline in type and appears to contain a high drilling water component (I^-).

Redox-sensitive parameters

Surprisingly, the groundwater is marginally oxidising as evidenced by an Eh of +10 mV and low to negligible amounts of Fe(II) and S(-II). The presence of small amounts of O_2 (0.25 mg/l) perhaps supports a near-surface water component.

Isotope geochemistry

The more saline groundwater is characterised by lower $\delta^{18}\text{O}$ and $\delta^2\text{H}$ values (-13.6 ppt and -99.4 ppt respectively) than for non-saline waters; the tritium value (8 TU) indicates a small younger water component. No radiocarbon data are available.

Uranium geochemistry

Dissolved uranium is present in low amounts (0.06 ppb for one method and below the level of detection for the other) and the $^{234}\text{U}/^{238}\text{U}$ activity ratio records a value of 2.8 which is markedly nearer to unity than level 222 - 224 m although still indicating isotopic disequilibrium in the groundwaters.

Summary

From hydrological considerations no representative groundwater should be possible from the demarcated zone. The water collected is therefore most likely from the borehole, having been pumped around the packer system either directly or via a network of interconnecting fractures through the bedrock. However, the sampled water shows saline properties which contrasts with the borehole water composition thought to have been collected from the higher levels. This saline water must therefore have come from the bedrock section being sampled, or via a fracture system leading to greater depths. Sufficient water was available as can be observed from the uniformity of water chemistry during sampling (Laurent, 1983b), in point of fact during sampling there was a tendency for the salinity to increase slightly and the the I^- content to sympathetically decrease from 13.4 - 10.2 %. Although the water is contaminated to some extent by drilling water, and as can be seen from the tritium content by a younger component also, sufficient saline water has been

available to influence the composition significantly. The groundwater collected from this level is thus characterised by:

- residual drilling waters
- younger, more near-surface waters from the upper horizons of the bedrock
- component of more typical marginal reducing groundwaters probably from the vicinity of the fracture Zone 4
- saline groundwaters of limited quantities from the sampled level or from deeper levels via fractures, which are probably approaching representative compositions for these depths.

5.2.2.4 Level 512 - 514 m (approx. 498 m)

The geology of the cored section consists of veined migmatite gneiss with a decimetre thickness of pegmatite; this is in contact with a more substantial pegmatite which occupies about 80 cm of the sampled section. The migmatite is weakly fractured comprising mostly single fractures (up to 10) with two narrow (2-3 cm) fracture zone bands consisting each of 3 fractures. The intersection angle with the axis of the core ranges from 10° to 90° and the main fracture filling minerals are chlorite and laumontite with subordinate calcite.

Hydrology

The sampled horizon is characterised by a very low permeability ($K = 9.5 \cdot 10^{-12}$ m/s); this will result in only very small amounts of contaminating water (i.e. drilling and borehole waters) entering the bedrock although the head deviation (-3.5 m) is not especially small. The water budget calculation (Fig 5.38) points to a groundwater which should be representative of the

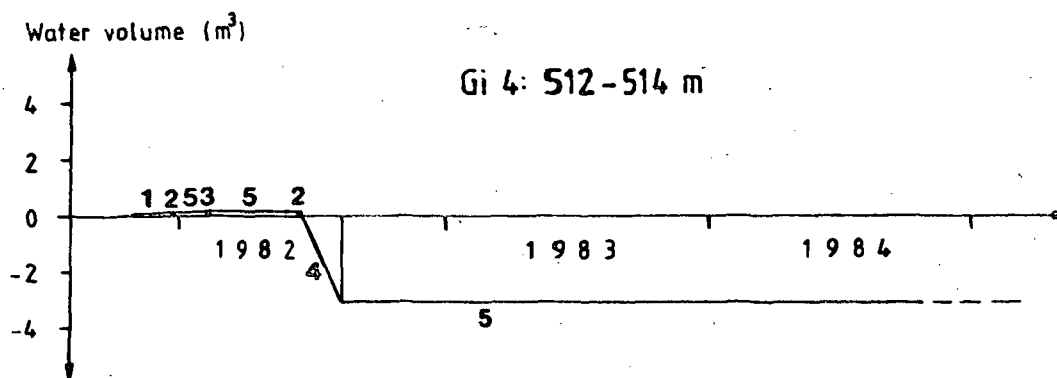

Figure 5.38: Schematic illustration of the calculated water budget for level 512-514 m in borehole Gi 4 (Gideå). 1 = Drilling water; 2 = Gas-lift pumping; 3 = Hydraulic testing; 4 = Sampling; 5 = Open-hole effect.

sampled depth. On the other hand the low K-value will limit the amount of water that can be taken from the bedrock section.

Water geochemistry

The collected groundwater shows certain similarities with the uppermost level sampled (Table 5.10b), i.e. when compared with average non-saline groundwaters from Swedish bedrock Na^+ is lower, Ca^{2+} is higher, and Cl^- and HCO_3^- are both lower, Cl^- markedly so. Although the pH is still rather high (8.8), the general characteristics of the groundwater point to a surface/near-surface origin with a deeper groundwater component. Low amounts of I^- are present (0.3 %) indicating little drilling water contamination.

Redox-sensitive parameters

An Eh of -50 mV indicates a marginally reducing groundwater; this is supported by negligible amounts of O_2 and S(-II). The high Fe(II) content (7.3 mg/l) is anomalous and may, as explained for some of the above-described horizons, be due to reaction in the borehole between the steel piping and borehole waters.

Isotope geochemistry

The stable isotope data ($\delta^{18}O = -12.94$ ppt and $\delta^2H = -94.1$ ppt) indicate a meteoric origin to the groundwaters. A combination of a very high tritium content (49 TU) and low radiocarbon age (3850 years) point to a young water component being present.

Uranium geochemistry

The dissolved uranium content is low (<0.2 to 0.44 ppb); the $^{234}U/^{238}U$ activity ratio is 2.4 which is similar to the preceding horizon and indicates disequilibrium in the groundwaters.

Summary

Due to the low permeability of the sampled section, only small amounts of contamination into the bedrock were expected. However, the chemistry of the groundwaters show that they are composed primarily of a young, surface to near-surface component, as indicated by both the chemical and isotopic data. It seems possible from the geology that the cored section represents a relatively impermeable bedrock horizon with the result that during pumping a partial vacuum was established within the sampling section. As the only substantial water source was the water in the borehole, this was pumped into the

sampling section either directly between the packers and the borehole wall, or via an open system of interconnecting fractures. The waters sampled thus represents surface to nearsurface waters which have collected above the packer system. Once the hydraulic connection between the borehole water and the sampled section was established, there was a continuous flow of water during the sampling period. This is shown by the constant chemistry of the waters during sampling (Laurent, 1983b).

5.2.2.5 Level 616 m - drillhole bottom

The sampled section represents some 75 m of drillhole which intersects two major fracture zones, i.e. Zone 4 at 606-655 m and Zone 6 at 670-690 m. The section is thus extensively fractured and the variation in rock-type and fracture mineralogy noted for the upper part of the borehole continues for the full extent of the hole.

Hydrology

This drillhole section has an estimated K value of 1.10^{-10} m/s and an estimated head deviation of 4 m of water. The water budget calculations (Fig 5.3) appear to be promising for a representative water sample to be obtained. However, the water removed prior to sampling amounted to only 70 litres which is less than 40% of the total volume sealed off in the borehole section.

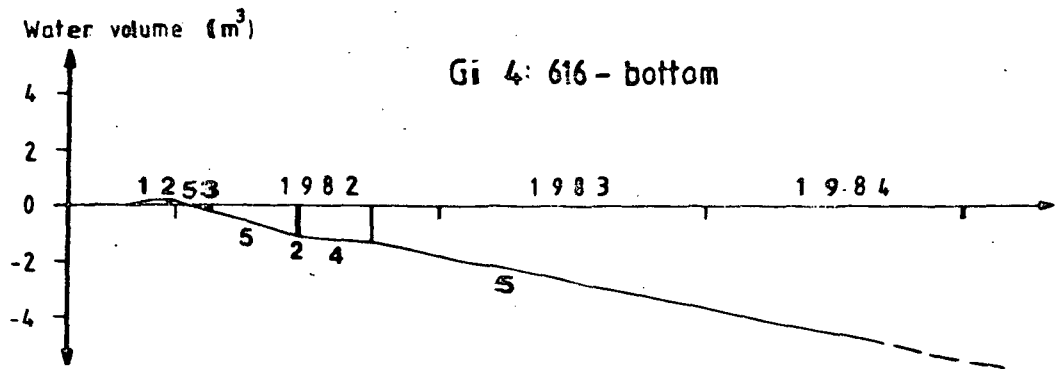

Figure 5.39: Schematic illustration of the calculated water budget for Level 616-bottom in borehole Gi 4 (Giceá). 1 = Drilling water; 2 = Gas-lift pumping; 3 = Hydraulic testing; 4 = Sampling; 5 = Open-hole effect.

Water geochemistry

The sampled groundwater is characterised by a pH of 8.8, high amounts of Na^+ , Ca^{2+} and Cl^- and low HCO_3^- ; the content of I^- is very high (24 %) and may indicate a considerable drilling water component. Compared to a typical non-saline groundwater, this horizon is distinctly saline (260 mg/l Cl^-).

Redox-sensitive parameters

The groundwater is markedly reducing ($E_h = -290 \text{ mV}$); this is supported by the absence of O_2 . No analyses of Fe(II) and S(-II) are available.

Isotope geochemistry

Similarly to the more saline waters encountered from section 404-406 m, the stable isotopes exhibits more negative values ($\delta^{18}\text{O} = -13.81$ ppt; $\delta^2\text{H} = -100.8$ ppt) although still indicating a meteoric origin. A tritium value of 10 TU infers a significant younger water component; no radiocarbon data are available.

Uranium geochemistry

Dissolved uranium values are very low (0.02 ppb); the $^{234}\text{U}/^{238}\text{U}$ activity ratio value is 2.0 which indicates disequilibrium in the groundwaters.

Summary

Because of the borehole length sampled, a mixture of groundwaters from different sources is inevitable. The question is whether all the groundwater has originated at the depth of sampling (i.e. 616 m to the borehole bottom), and is therefore representative of deep groundwaters, or has there been a substantial contaminating component from higher levels. The chemistry of the water indicates that considerable mixing has occurred; the tritium and I^- contents show mixing from drilling water and younger near-surface waters although at the sampled depths a strongly reducing environment has been maintained. From the data compiled by Laurent (1983b), a steady increase in Na^+ , Ca^{2+} and Cl^- occurred during the sampling period, with a corresponding decrease in HCO_3^- ; the drilling water tracer I^- gradually increased from 4.4 % to 16.5 %, with local highs of up to 29.9 %. The groundwaters from this section are thus composed of:

- residual drilling waters
- younger, near-surface component
- deep reducing saline groundwaters

The gradual increase in salinity during pumping, i.e. probably the removal of higher level-derived groundwaters, is supported by the hydrological data which indicated that only 40 % of the borehole water in the sealed section had been removed prior to sampling. Continued pumping would most likely have resulted in increasingly more saline groundwater. In this respect it is interesting that the I^- content appears also to increase. Does this represent natural iodine levels in the water, or does it indicate that considerable amounts of drilling water have been unsuccessfully removed by gas-lift pumping? The former explanation would appear to be more plausible.

5.2.2.6 Borehole summary and discussion

From hydrogeological considerations five suitably conducting horizons have been selected from borehole Si 4 for chemical characterising of the groundwaters. One of these levels represents the intersection with a major local fracture Zone 3A (217-259 m) which is believed to extend to the bedrock surface; the lowest level, which in reality comprises a borehole length of some 75 m, includes the intersection with two local fracture Zones 4 and 6, also thought to extend to the bedrock surface.

The natural groundwater flow in the near vicinity of the borehole according to measured piezometric head tends to be generally downwards in the upper regions (0-300 m) and upwards in the lower regions of the borehole. With the exception of the lowest sampled section, which is estimated to have a positive piezometric head, the remaining levels are considered negative. The water budget calculations suggest that the upper three levels are problematic with regards to suitably representative groundwater samples; this is attributed to the noted negative piezometric heads (levels 96-98 m and 222-224 m) resulting in important open-hole effects, and in rock impermeability (level 404-406 m) resulting in inadequate

volumes of water. The lower two levels (512-514 m and 616-bottom) are considered more hopeful although the former level maybe somewhat impermeable.

The groundwater chemistry shows that degrees of contamination are evident from all the sampled levels. In general terms, two of the levels (404-406 m and 616-bottom) are characterised by saline groundwaters (178-260 mg/l Cl^-) with a high I^- content which may reflect natural background values rather than excessive drilling water contamination. These, however, are contaminated by small amounts of younger, near-surface groundwater (8 - 10 TU); in addition the higher level groundwater is marginally oxidising (+10 mV) compared to the deepest sampled level (-290 mV) which can be considered truly reducing. In both cases the degree of salinity increased during sampling so that a more saline and reducing groundwater would probably be typical for these sampled depths. Two of the remaining three levels (levels 96-98 m and 512-514 m) are characterised by groundwaters of typical surface and near-surface chemistry, i.e. lower than normal Na^+ and Cl^- and higher Ca^{2+} when compared with non-saline groundwaters from Swedish bedrock. High tritium contents (36-49 TU) at both levels and a young (diluted) ^{14}C age (3850 years) from the 512-514 m level, support a major near-surface component to the waters. The remaining level at 222-224 m shows groundwater compositions normal for non-saline waters. Moreover, it is characterised by low tritium amounts (5 TU), an old radiocarbon age (11895 years), and is moderately reducing (-60 mV). This water would appear to be representative for the depth sampled and can be regarded as shallow to intermediate in origin.

Much of the observed contamination is due to the incursion at depth of younger, near-surface waters. From hydrological considerations there are indications that the general water-flow direction in the upper part of the borehole is downwards. This can, therefore, adequately

explain the presence of such waters at the 96-98 m level, and even as deep as the 512-514 m level. In the former case open-hole effects contributed to the high surface-derived content, and in the latter case low conductivity has resulted in the near-surface-derived borehole water being pumped around the packer system into the sampling section. At level 212-214 m similar open-hole effects to the uppermost level should have resulted in a sizable younger, near-surface water component, which is known to have penetrated to deeper levels. Its relative absence at the 212-214 m level suggests that the more surface-derived borehole waters have been largely removed and replaced by shallow to intermediate groundwaters representative of the sampled section. This has been probably facilitated by the presence of the highly conductive zone 3A which dominates this part of the borehole from 211-255 m.

The increase in groundwater salinity and reducibility with depth as suggested by the waters sampled from levels 404-406 m and 616 m - bottom, probably reflects the true groundwater situation, although in a much diluted scale due to contamination from other sources. The presence of older, more saline water within the lower borehole sections is supported by the hydrology which indicated an upward groundwater direction flow, i.e. from deeper, more saline levels. This upward water trend may explain the systematic increase in salinity of the groundwaters during the sampling period.

Increase in reducing conditions, in addition to being indicated by more negative Eh measurements (i.e. -290 mV for the deepest section), is also suggested by low dissolved uranium values (i.e. 0.02 ppb for the deepest section). Regarding the $^{234}\text{U}/^{238}\text{U}$ ratio values, level 212-214 m recorded 6.7 which is high and suggests a long residence time for the groundwater so that alpha recoil processes have made a significant contribution to the excess ^{234}U . Furthermore, this value is similar to the range of activities obtained for the three

analysed Gi 2 levels ($^{234}\text{U}/^{238}\text{U}$ activity ratios of 5.4 - 7.7). The remaining ratio values for the Gi 4 borehole are considerably lower (2.0 - 2.8) and, although still indicating widespread disequilibrium in the groundwater environment, show that mixing with other groundwaters has occurred and that any original isotopic signature that may have indicated long residence times has been effectively destroyed.

Table 5.11: Uranium content and theoretical Eh values of the groundwater from borehole Gi 4.

Level (metres)	Uranium Content (ppb)	Calculated Eh (mV)
96 - 98	1.02	-128
222 - 224	0.98	-268
404 - 406	<0.2	-283
512 - 514	<0.2	-266
616 -	<0.1	-262

Even though the uranium contents show a distinct boundary between the upper two and the lower three levels, the apparent systematic variation with depth is complicated by groundwater contamination described above. In Table 5.11 and Figure 5.40 the analytical uranium contents and the theoretically calculated uranium solubilities for both crystalline and amorphous UO_2 at a pH of 8.10 and 9.50 are presented and plotted as a function of Eh.

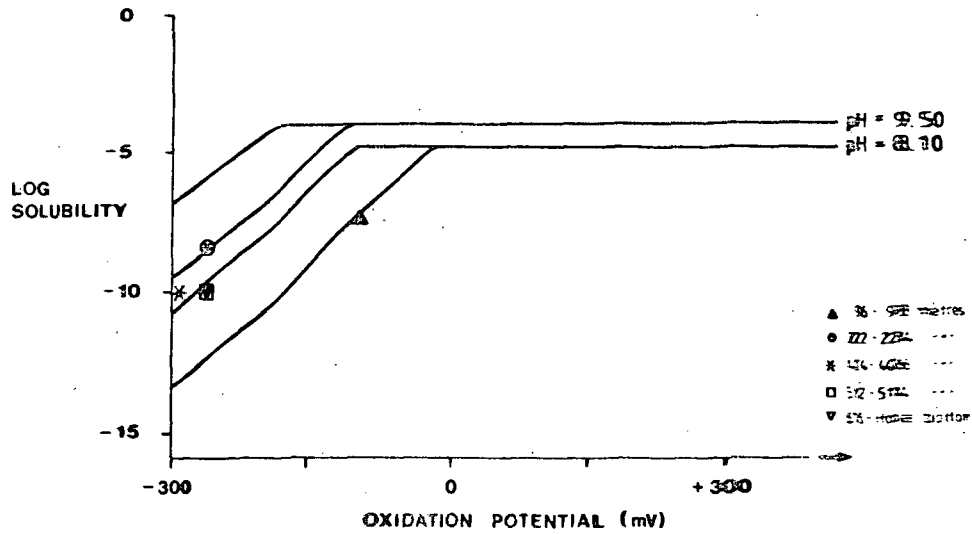

Figure 5.40: Plots of uranium content (expressed as log (mol/litre)) and the calculated theoretical Eh values of groundwaters collected from borehole G1. The values are plotted with respect to theoretical uranium solubility curves calculated for amorphous (lower stability limit) and crystalline (upper stability limit) UO_2 at a pH of 8.10 and 9.50.

5.3 Svartboberget

The Svartboberget test-site, which forms part of the Voxna region (375 km²), is located in the western part of the county of Hälsingland, some 260 km north-west of Stockholm and approximately 80 km due west of the Baltic Sea (Fig 1). Topographically, the most prominent features in the region are a series of hills and valleys aligned in a N-NW direction. The south central part of the Voxna region is sub-divided by such parallel valleys into three areas which are 2 - 2.5 km wide and more than 8 km long. The smoothly sculptured hill of Svartboberget constitutes the centrally located area. The differences in altitude between the highest point of the site, approximately 305 m above sea-level, and the lowest parts of the adjacent valleys, are 70-85 m (Fig 5.41).

The regional geology of the Voxna region has been previously described by Lundquist (1963) and Lundegårdh (1967). As a result of SKB investigations during the period 1979-1982, the detailed geology has been described by Tirén et al (1981), Tirén (1982), and later summarised by Ahlbom et al (1983d).

A map of the Svartboberget area showing the general topographic features, together with the main zones of structural weakness, is illustrated in Figure 5.42. The regional bedrock is dominated by migmatite (mostly of sedimentary origin) and gneisses. These were formed during the Svecokarelian orogeny (approx. 1800-1900 Ma); at a relatively early stage granites and subordinate amounts of basic rocks were intruded into the older basement rocks. These igneous rocks, the so-called Old Granites, are to-day deformed and referred to as granite gneiss. The youngest rocks in the area are dolerite dykes estimated to be around 1200 Ma old.

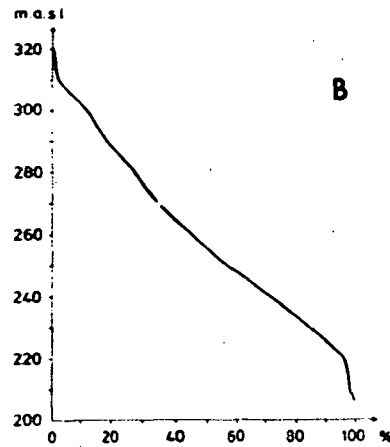
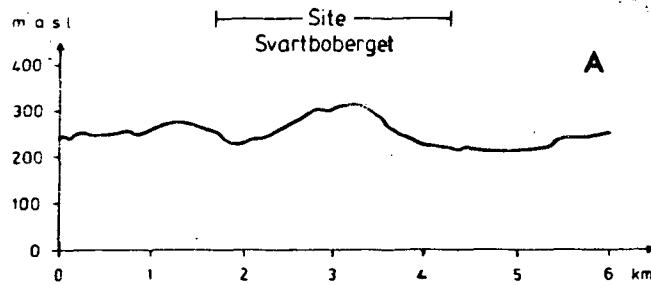

Figure 5.41: The Svartboberget test-site. A: Topographic profile across the site; B: Hypsographic curve showing altitude characteristics.

As a result of 14 shallow percussion boreholes (down to a maximum depth of 150 m) and 7 deep cored boreholes (to a vertical maximum depth of 800 m) the bedrock of the site consists of 95 % migmatite which has a maximum thickness of at least 800 m. Intercalated throughout the migmatite are lenses and schlieren of quartzite and rocks of varying grain-size. These represent variations of the primary sediments which occurred within the dominating pelitic host sediments.

A grey granitic component (<0.5 % of the bedrock) also occurs within the migmatite. Formed during migmatization, this granite conforms to the internal structural trends of the migmatite, and locally forms a transitional contact with the migmatite, although sharp contacts are also observed. The presence of these granitic bodies (usually minor, irregular, and medium- to coarse-grained) appears to have an annealing effect on the bedrock.

Greenstones constitute 2-3 % of the bedrock, occurring as evenly distributed layers and lenses parallel to the foliation of the migmatite. The average thickness of these layers is less than one metre, and the composition ranges from amphibolitic to gabbroic.

Structurally, the Svartboberget site is bounded to the NE and SW by N-NW trending, fracture-defined valleys, which are widest when they intersect minor NW-orientated valley/fractures (Fig 5.42). These major NW striking regional fracture zones dip 30-40 degrees to the SW and can be followed for 10-15 km. They can exceed 30 m in width and normally comprise sets of parallel fractures often with a central part of crushed rock (less than 5 m) surrounded by narrow sections of high fracture frequency. The central parts are usually weathered and permeable to water. Approximately 40 km west of Svartboberget one of these zones delimits to the east an old granite/migmatite region (approx. 1800 Ma) from a younger (1400-1600 Ma) series of granites and volcanites. The zones are therefore extremely old and may have been re-activated approximately 900-1200 Ma ago during the Swedonorwegian orogeny when the area was subjected to compression from west to east.

The correlation between the major fracture type and distribution indicated topographically and geophysically is good within the test-site where there is an insignificant soil depth. In all, 17 local fracture zones and 2 regional lineament zones have been located within

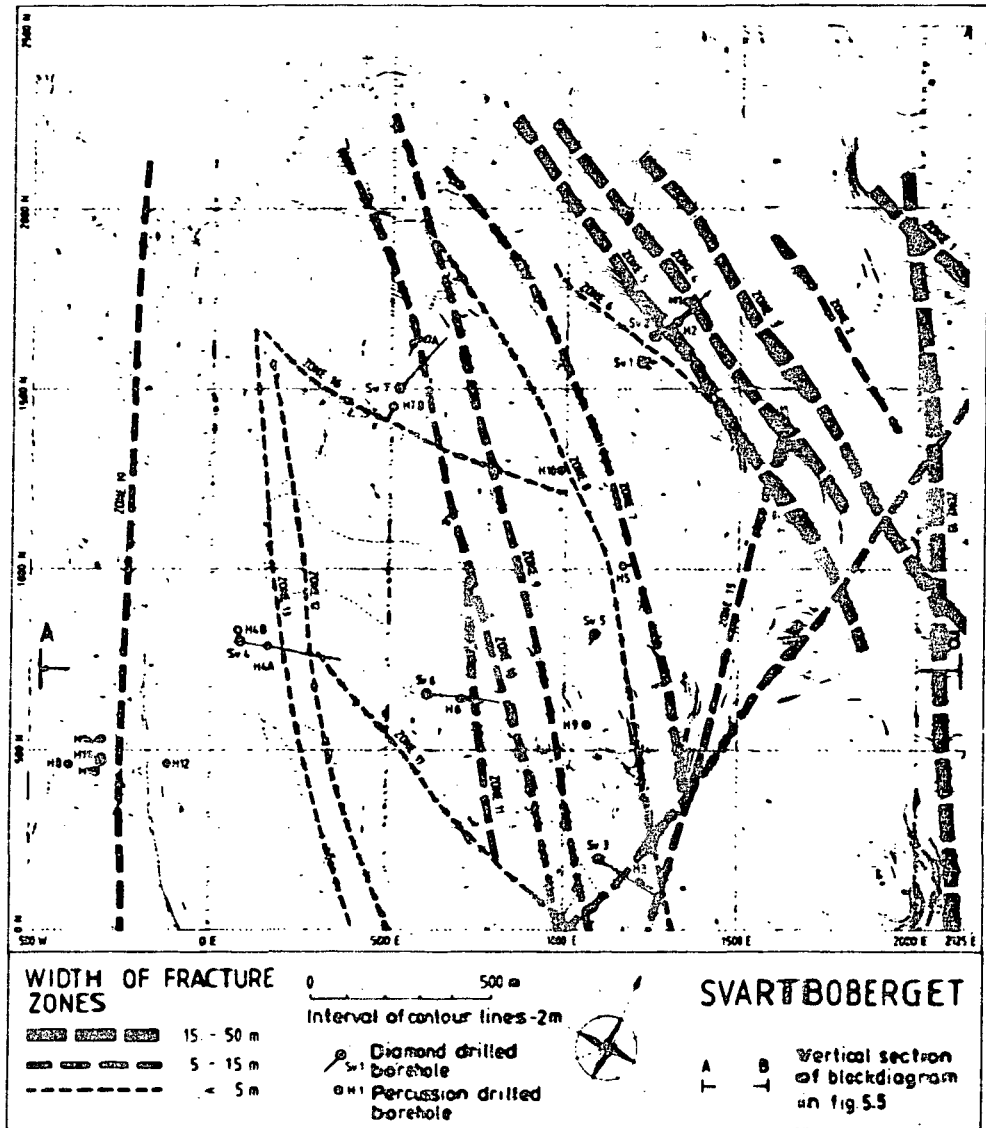

Figure 5.42: Topographic map of the Svartboberget test-site area showing the main structural zones of weakness, and the location of the 7 (Sv 1 to Sv 7) cored boreholes. (After Tirén et al 1981).

the test-site. The mutual distance between the local fracture zones as indicated on the surface are generally 100-500 m. To the NE of the area the occurrence of local zones is very marked (Zones 1-6); the width of these zones ranges from 5-50 m and they are on average 30-80 m apart. The remaining local fracture zones are 2-15 m wide and the overall dip varies from 30-90 degrees, mostly towards the south and south-west.

Surface outcrop measurements of rock mass fracturing revealed a dominant strike of north to north-east, i.e. at a high angle to the foliation in the migmatite. These fractures show no indication of movement and are probably tension fractures. The frequency of fractures longer than 0.5 m in outcrop is 1.0 fractures/m. At depth, the fracture frequency in the rock mass between the local fracture zones which records an average of 2.6 fractures/m, varies insignificantly. The rock mass to the west of the area has a low fracture frequency (1.6 fractures/m) which contrasts eastwards whereupon 2.7 fractures/m occur. This difference is partly due to a greater density of fractures out-cropping to the east, and the fact that boreholes in the western part penetrate most of the fracture zones at depth.

Taking individual rock-types, the total fracture frequency for the various rocks irrespective of depth is lowest in the migmatite granite (2.7 fractures/m) followed by migmatite gneiss (4.1 fractures/m), gneiss granite (4.9 fractures/m) and finally greenstone (6.8 fractures/m). The most common fracture minerals are chlorite, calcite and illite. Illite usually appears in the form of thick coatings of up to 2 mm thick on shear surfaces; otherwise as a thin film on fracture surfaces. Chlorite is present especially on fracture surfaces parallel to the foliation. Zeolite minerals are also sometimes observed within the large-scale fracture zones.

The hydrological features have been described by Gentzschein (1983a) and summarised by Ahlbom et al (1983d). The Svartboberget test-site is located within the drainage basin of the Voxna river (3708 km²), whereupon some 6 % constitutes lake water. The Voxna forms a tributary to the Ljusnan river (approx. 20 000 km² catchment area) and they confluence some 40 km downstream from the site. After an additional 40 km the river discharges into the Baltic Sea. The test-site can largely be subdivided into two drainage areas delineated by two streams flowing east and west respectively. The local topography of Svartboberget indicates a groundwater recharge area, with the main discharge areas located in low-lying areas around the margins.

The water balance of the Svartboberget site has been calculated to:

Adjusted precipitation	715 + 50 mm
Actual evaporation	390 + 50 mm
Run-off	300 + 15 mm

The precipitation excess of 25 mm can partly be explained by the uncertainty in measuring the various parameters, but can also be partly attributed to the permeation of groundwater through the Quaternary deposits so that the run-off values is underestimated. However, in the long term, the run-off corresponds to the groundwater recharge of which most is cycled within the soil cover and the surficial bedrock, and only a very small percentage percolates to depth.

Climatically, the site is located in a region characterised by two periods of groundwater recharge and discharge. The former occurs in the Spring and Autumn. The highest groundwater levels result from snow melting in the Spring, and the lowest levels just prior to the melting period or at the end of the Summer. The mean groundwater temperature in the area varies between 4 and 5 degrees C (Knutsson and Fagerlind, 1977).

The groundwater table profile is a smoothed version of the general Svartboberget topography. From measurements conducted in the site area, the depth of the groundwater table is estimated to be 10-15 m (in some cases >25 m) within the higher relief regions and along the slopes; in the lower parts the level is only some 0.5-1 m below the surface. Generally, the altitude of the groundwater table varies from approximately 220-305 m above sea-level. Very localised discharge areas exist as indicated by two of the boreholes which are artesian in character.

The local groundwater flow in the test-site is primarily orientated towards the regional fracture zones which determine the valley directions not only to the west and east, but also in a northerly trend. From a regional aspect, the groundwater flow is apparently towards the Voxna river to the south and south-west where the low-lying parts of the area are located.

5.3.1 Borehole Sv 4

Borehole Sv 4 was drilled at 60° to a vertical depth of 569 m (borehole length 641.5 m) in order to confirm the presence at depth of the large-scale NW-SE trending local fracture zones indicated on the surface by aerial and ground geophysical methods (see Fig 5.42). In addition, the borehole was planned to intercept a positive anomaly associated with one of the fracture zones; this may indicate the presence of a dolerite dyke. Of the fractures, three major zones were located; Zones 17, 13 and 15 at 435-437 m, 545-549 m, and 643-648 m respectively. Zone 13 represents the fractured dolerite dyke (Fig 5.43).

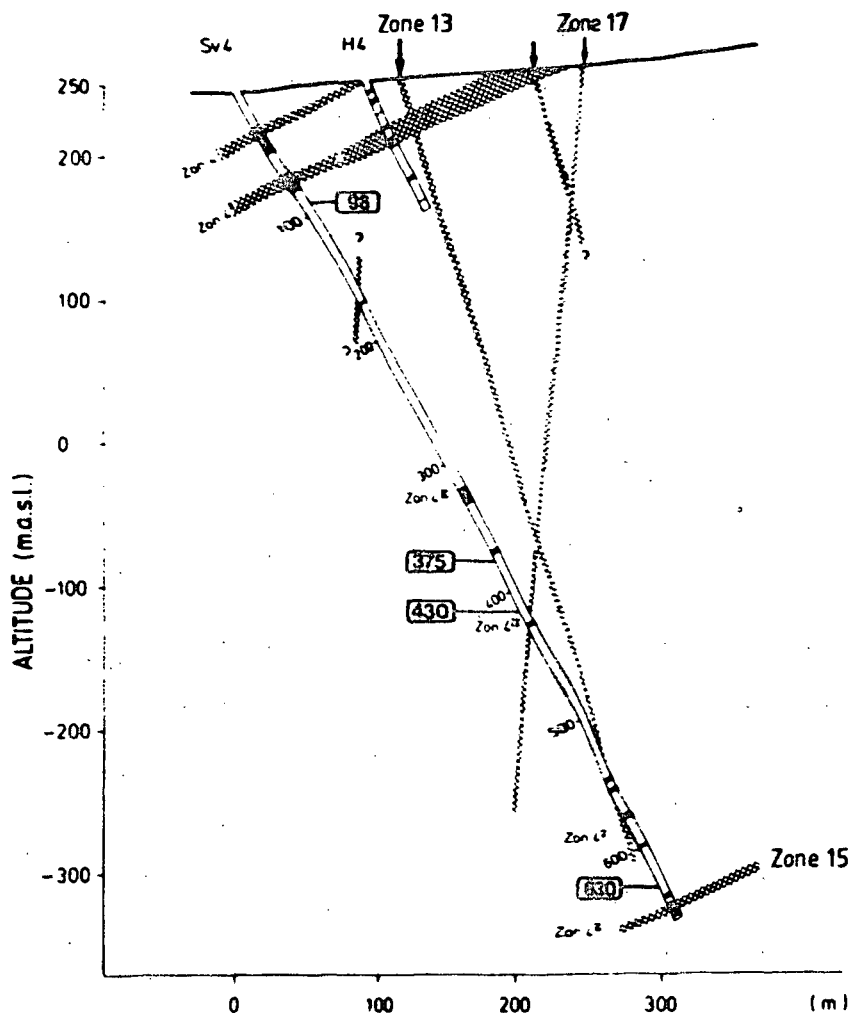

Figure 5.43: Location of the major local fracture zones and their relationship with the groundwater sampling horizons: (Borehole Sv 4).

The dominant rock-type intercepted by the borehole is migmatite gneiss (67 length %), followed by migmatite granite (28 length %) and greenstone (5 length %). The migmatite gneiss is typically veined (mainly quartz/feldspar-rich matrices) and is fairly evenly distributed

throughout the hole. The migmatite granite has a very low content of mafic constituents and feldspar commonly dominates over quartz; garnet occurrences are quite common. Texturally, this granite is medium- to coarse-grained, and often contains lenses of gneissose material, sheared out along the foliation trend. The thickest occurrence is about 42 m; the granite occurs mostly within the upper bedrock horizon (30-315 m) and the lowest horizon (600-650 m).

The greenstone horizons (average thickness 0.6 m; maximum around 3 m at 574 m depth) comprise amphibolite, biotite altered greenstones, and dolerite. The amphibolite varieties usually occur along shear zones.

The average number of fractures/metre for the borehole is 1.9; of the representative rock-types greenstone exhibits the highest (5.2 fractures/metre), followed by migmatite gneiss (1.9 fractures/metre) and finally the migmatite granite (1.3 fractures/metre). In the uppermost borehole horizon (down to approx. 300 m) the most marked fracture frequency occurs between 30-80 m; for local fracture Zones 17 and 15 the fracture frequency is 5.0-9.9/metre; Zone 13 is considerably weaker at 1.0-1.9 fractures/metre.

Hydrologically, Sv 4 is located in the lower part of a slope and in a direction beneath the hill such that the immediate vicinity can be considered a local groundwater discharge area, with an expected increase in piezometric head with depth. In the upper 200 m of the hole the hydraulic conductivity varies from 1.10^{-9} m/s to 1.10^{-7} m/s, which is quite normal for this depth (Fig 5.44b). At greater depths the conductivity is near the limit of measurement apart from three exceptions, two of which correspond with local fracture Zones 17 and 15 which record calculated values of 2.10^{-7} m/s and 2.10^{-9} m/s respectively. The piezometric head measured along the hole show excess pressure, according

Table 5.12a: Measured hydraulic parameters and calculated water budget values of the various influences due to borehole activities at the water sampled levels in borehole Sv4.

Level	K-value	Head deviation	Flow direction (borehole trends)	Drilling water (+)	Gas-lift pumping(-)	Hydraulic testing(+)	Open hole effect before sampling(±)	Sampled water before analysis (-)
(m hole length)	(m/s)	(m)		(m ³)	(m ³)	(m ³)	(m ³)	(m ³)
96-108	8.4·10 ⁻⁸	+1.0	*	1.86	0.88	0.032	-5.52	3.6
376-378	6.5·10 ⁻⁹	+17.4	*	0.22	0.69	0.003	-7.82	4.1
430-432	1.9·10 ⁻⁸	-	?	0.54	0.195	0.007	?	4.1
630-632	2.0·10 ⁻¹⁰	-	?	0.001	0.002	<0.001	?	3.9

* 25 m section; head deviation from hydrostatic head in the borehole (in metre of water).

Table 5.12b: Measured hydraulic parameters and calculated water budget values of the various influences due to borehole activities at the water sampled levels in borehole Sv4.

Level	K-value	Head deviation	Flow direction (borehole trends)	Drilling water (+)	Gas-lift pumping(-)	Hydraulic testing(+)	Open hole effect before sampling(±)	Sampled water before analysis (-)
96-108	8.4·10 ⁻⁸	+1.0	*	1.86	0.88	0.032	-5.52	3.6
376-378	6.5·10 ⁻⁹	+17.4	*	0.22	0.69	0.003	-7.82	4.1
430-432	1.9·10 ⁻⁸	-	?	0.54	0.195	0.007	?	4.1
630-632	2.0·10 ⁻¹⁰	-	?	0.001	0.002	<0.001	?	3.9

* 25 m section; head deviation from hydrostatic head in the borehole (in metre of water).

?

?

?

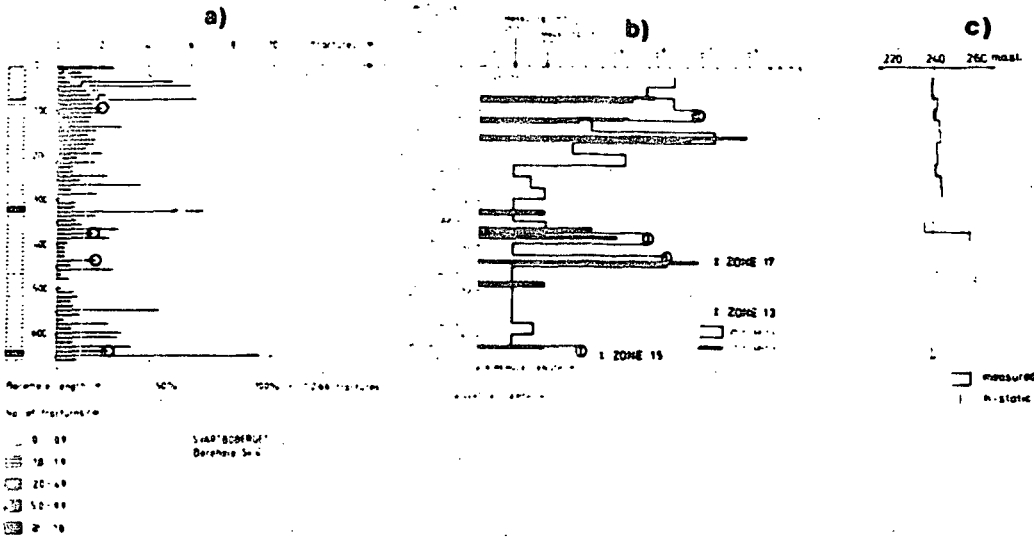

Figure 5.44: Hydrogeological characteristics of borehole Sv 4.

a) Fracture frequency (for 10 m sections) and the cumulative percentage of fractures.

b) Hydraulic conductivity.

c) Piezometric head distribution and hydrostatic head in the borehole.

to the hydrostatic head, along a major length of the hole (Fig 5.44c); the greatest head deviation exceeds 17 metres of water (below 420 m piezometric head measurements are missing due to a default with the head transducers). The uppermost part of the hole is characterised by small negative head deviations. The groundwater level in the borehole is very near the ground surface for most of the year.

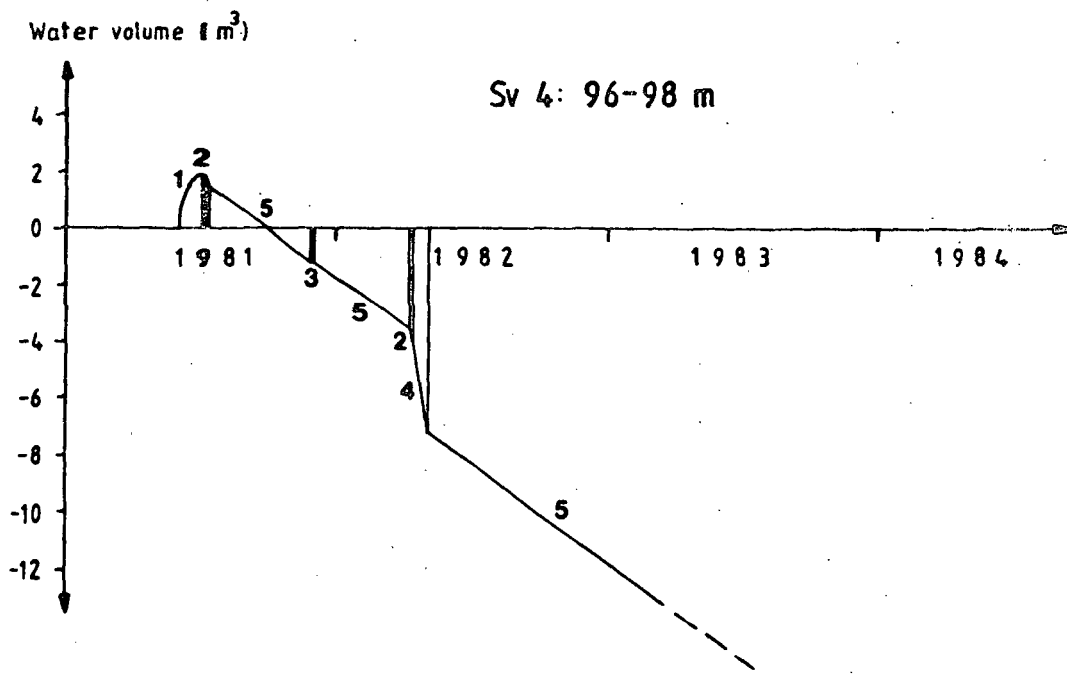

Figure 5.45: Schematic illustration of the calculated water budget for level 96-98 m in borehole Sv 4 (Svartboberget). 1 = Drilling water; 2 = Gas-lift pumping; 3 = Hydraulic testing; 4 = Sampling; 5 = Open-hole effect.

5.3.1.1 Level 96-98 m (approx. 83 m)

The sampled section is located within a light-coloured, garnetiferous migmatite granite with local biotite-rich zones. The borehole length is characterised by three simple fractures which intersect the axis of the core at angles ranging from 55° to 90° . The dominating fracture minerals are chlorite, epidote and an unidentified mafic mineral. Very close to the upper part of the section, and covered by the packer length, is a fracture zone 20 cm wide comprising four fracture zones which show evidence of weathering.

Hydrology

A high hydraulic conductivity ($K=8.4 \cdot 10^{-8}$ m/s), in combination with a positive piezometric head deviation (+1.0 m), should contribute to a suitable water sampling situation. The one injected 5 m borehole section resulted in a lower conductivity value (and also a positive head deviation) than the overall 25 m section. This, however, is no guarantee that the fractures in the actual sampled section are in fact water conducting. The water budget calculations based on measurements along the 25 m section are presented in Table 5.12a and illustrated in Figure 5.45.

Water geochemistry

The sampled water (Table 5.12b) is characterised by a pH of 8.4; of the major cations, Na^+ is present in slightly lower, and Ca^{2+} in slightly higher amounts than for normal non-saline groundwaters in Swedish crystalline rocks. Cl^- is low and HCO_3^- is normal for such shallow groundwaters. The presence of 1.0 % I^- indicates a significant drilling water component.

Redox-sensitive parameters

A positive Eh value (+50 mV), together with a near absence of Fe(II) (0.04 mg/l) and S(-II) (<0.01 mg/l), indicate a groundwater largely derived from a near-surface environment. This is further supported by a sizeable oxygen content (0.42 mg/l).

Isotope geochemistry

This level is characterised by $\delta^{18}\text{O}$ and $\delta^2\text{H}$ values (-12.51 ppt and -90.0 ppt respectively) indicative of a meteoric water source (Fig 5.6). The tritium data of 5TU indicates a small surface-derived component; no ^{14}C data are available.

Uranium geochemistry

The dissolved uranium content is 3.47 ppb which is high and supports an oxidising groundwater environment. No isotope data are available for this level.

Summary

The results show that the level sampled is characterised by waters which represent:

- small residual near-surface/drilling water component.
- shallow groundwaters.

The presence of oxygenated near-surface groundwaters is a function of the shallow depth of the sampled level, in combination with high conductivity and a positive piezometric head. However, the actual section length sampled is quite compact and free of any major fractures. There is therefore the real possibility that the waters sampled represent borehole water obtained from higher-

level conducting fracture zones which have channelled near-surface groundwaters (containing small quantities of marked drilling water) into the borehole.

5.3.1.2 Level 376-378 m (approx. 324 m)

The main rock-type along this section is a fine- to medium-grained grey gneiss granite; grain size can be heterogeneously distributed. Structurally, the section consists of four single fractures which intersect the core at angles varying from 45° to 90° ; the main fracture filling minerals are calcite and one fracture shows signs of weathering.

Hydrology

The sampled section length has a hydraulic conductivity of $6.5 \cdot 10^{-9}$ m/s and an unusually high excess pressure (+17.4 m; Table 5.12a). Two 5 m sections have been injection tested, one of which includes the most fractured part of the 25 m sections (incorporates 3 fracture zones). Both of these 5 m sections resulted in lower K-values. It is therefore more plausible that the sampled section containing only four single fractures should be represented by the calculated water budget illustrated in Figure 5.46, which favours a contamination-free groundwater sample. The distribution of fractures along the rest of the 25 m section is similarly low.

Water geochemistry

The sampled groundwater has a pH of 9.0 and a major cation and anion content typical for a shallow to intermediate non-saline groundwater. However, a sizeable I^{-} content (1.9 %) indicates a significant drilling water component.

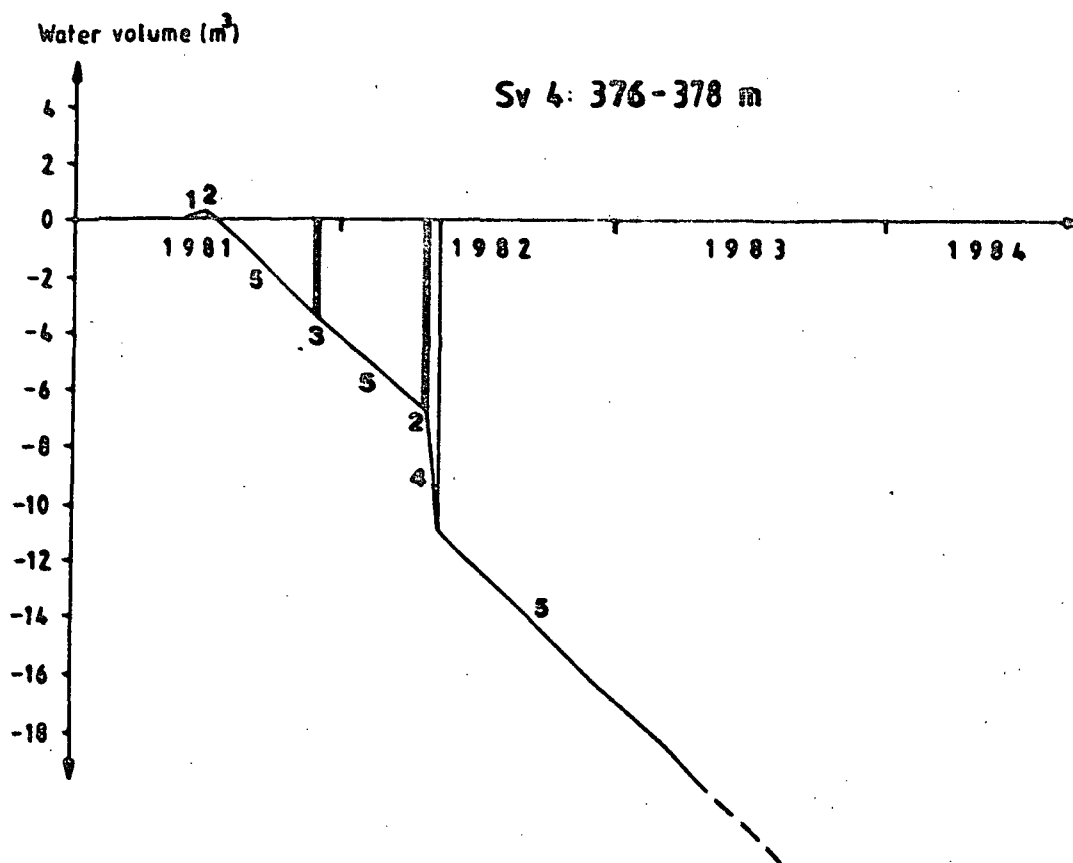

Figure 5.46: Schematic illustration of the calculated water budget for level 376-378 m in borehole Sv 4 (Svartboberget). 1 = Drilling water; 2 = Gas-lift pumping; 3 = Hydraulic testing; 4 = Sampling; 5 = Open-hole effect.

Redox-sensitive parameters

A strongly reducing groundwater environment is indicated by an Eh value of -130 mV and significant amounts of Fe(II) (0.21 mg/L) and S(-II) (0.03 mg/l); further indications include a virtual absence of oxygen (0.01 mg/l).

Isotope geochemistry

Stable isotope values ($\delta^{18}\text{O} = -13.22$ ppt, $\delta^2\text{H} = -95.3$ ppt) suggest a meteoric origin. A below detection limit of tritium (<3TU) indicates no contamination from young, surface to near-surface groundwaters, and a ^{14}C age of 14820 years is further reinforcement that this sample is representative for an intermediate non-saline groundwater.

Uranium geochemistry

Dissolved uranium contents are low (<0.01 - 0.22 ppb) and the $^{234}\text{U}/^{238}\text{U}$ activity ratio is high (3.3). This further supports a reducing environment and shows widespread isotopic disequilibrium due to an excess of ^{234}U .

Summary

Hydrologically, the water budget calculations from the measured 25 m section indicate that a representative groundwater sample should have been possible; however, the actual sampled 2.7 m section may be doubtful because of an absence of convincing water-conducting fractures. The chemistry of the water supports the water budget calculations in that a representative sample was in fact obtained. The only negative feature is the low but significant iodine content which indicates the presence of some drilling water contamination. It is proposed, therefore, that most of the water collected was from the borehole above or below the packer system. The origin of this water was probably from these conductive zones indicated from the hydrological data along the 25 m section, which may come from the sealed-off horizon. This groundwater is intermediate, non-saline in type, and is representative for the bedrock depth sampled. The small drilling water component probably comes from some

residual contamination in the borehole. The authenticity of the sample is supported by negligible tritium (<3TU), negative Eh (-130 mV), an absence of oxygen, and an old ^{14}C age of 14820 years.

5.3.1.3 Level 430-432 m (approx. 373 m)

This level is located within a thick horizon (approx. 30 m) of a grey, gneissose granite characterised by porphyroblasts/veins of feldspar and garnet; some biotite-rich horizons also occur. The section sampled is totally devoid of fractures; the nearest major fracture zone (Zone 17) occurs at greater depth some 2-3 m away.

Hydrology

Injection tests conducted along the 25 m section (Table 5.12a) show that 88 % of the water corresponds to local fracture Zone 17, which is known not to coincide with the actual sampled section. Measurements along a 5 m section, which includes Zone 17, also show a positive piezometric head of +3.6 metres.

Water geochemistry

The major chemical components show no significant variation from the above level (Table 5.12b). Some drilling water component is still present, as indicated by 1.0 % I^- .

Redox-sensitive parameters

There is an indication from these parameters that the groundwater is less reducing; for example, an Eh value of -50 mV and an increase of O_2 to 0.25 mg/l. The Fe(II) and S(-II) contents show little change, although the

absence of any S(-II) might be some support for a less reducing groundwater.

Isotope geochemistry

Little change in stable isotope composition can be observed. An absence of tritium (<3TU) and an old ^{14}C age (12935 years) suggest a good representative groundwater.

Uranium geochemistry

The dissolved uranium content ranges from <0.10 - 0.20 ppb, i.e. similar to the preceding level. The $^{234}\text{U}/^{238}\text{U}$ activity ratio is markedly higher and again indicates widespread disequilibrium in the groundwater.

Summary

The location of the sampled section within a fracture-free, non-conducting part of the borehole is not particularly conducive to groundwater sampling. The sampled water is therefore from the borehole, probably partly from above the packers, but even more probably from the highly conductive Zone 17 situated just below the packer system. The similarity in chemistry of this groundwater with the preceding level indicates that both samples mostly represent the same groundwater source. The less reducing nature of the present level may indicate some mixing with groundwaters from higher levels, although the chemical characteristics are similar. Residual drilling water from the borehole probably accounts for the detectable I^- content.

5.3.1.4 Level 630-632 m (approx. 551 m)

This level is characterised by a light-coloured pegmatitic granite containing subordinate bands (approx. 10-20 cm) of darker, biotite-rich gneiss. The investigated section contains a single weathered fracture orientated at 40° to the core axis.

Hydrology

The 25 m section which includes the sampled section records a hydraulic conductivity of $2.0 \cdot 10^{-10}$ m/s (Table 5.12a). No hydraulic head data are calculated because of defaulting pressure transducers. As the injection tests are considered to correspond only to local fracture Zone 15, it is highly doubtful whether the calculated water budget values reflect the actual situation prevailing along the sampled section located some 10 m above Zone 15.

Water geochemistry

A pH of 9.1 and major ion contents of 35 mg/l for Na^+ , 17 mg/l for Ca^{2+} , 7 mg/l for Cl^- , and 126 mg/l for HCO_3^- , demonstrate the similarity of this groundwater with the two preceding sampled levels. In some contrast, the iodine content (0.6 %) is lower and therefore suggests a smaller drilling water component.

Redox-sensitive parameters

Fe(II) and Si(-II) show similar levels to the previous level (0.27 mg/l and <0.01 mg/l respectively); the oxygen content, however, has increased slightly to 0.50 mg/l suggesting a greater near-surface component. The overall groundwater environment is reducing ($E_h = -110$ mV).

Isotope geochemistry

The stable isotope data (values for $\delta^{18}\text{O}$ and $\delta^2\text{H}$ are -13.10 ppt and -95.4 ppt respectively) show little deviation to the previous level. The absence of detectable tritium (<3TU), and the correspondingly old ^{14}C age (13210 years), indicate a relatively uncontaminated and representative groundwater.

Uranium geochemistry

Dissolved uranium is present in only very small amounts (<0.1-0.15 ppb). This, together with a high $^{234}\text{U}/^{238}\text{U}$ activity ratio of 4.1, suggest a deep reducing environment with widespread disequilibrium due to excess ^{234}U , probably caused by alpha-recoil processes.

Summary

Hydrological and geological considerations indicate that little water is possible from the sampled section length which reveals only one single fracture. The water sampled must therefore originate in the borehole, and the similarity in chemistry with the two preceding levels indicates a common source i.e. local fracture Zones 15 and 17. The small amounts of iodine tracer and the continued measurement of some oxygen show that some drilling water + a small surface component are still present, although the quantities involved are not sufficient to influence the isotopic data significantly.

5.3.1.5 Borehole summary and discussion

Geological mapping, and hydrological investigations carried out along 25 m sections (in some cases more detailed measurements have been conducted along 5 m lengths) in borehole Sv 4, have resulted on locating three major conducting horizons at depth, two of which correspond to the intersection of the hole with local fracture Zones 17 and 15. These are thought to extend to the bedrock surface.

The borehole is thought to be located in a local groundwater discharge area and therefore the piezometric head might be expected to increase with depth. Hydraulic measurements are reasonably high ($>1 \cdot 10^{-8}$ m/s) in and around the upper three investigated levels; the deepest level records a value of $2 \cdot 10^{-10}$ m/s. Positive piezometric head values, when possible to measure, characterise the two uppermost levels. As a consequence, the calculated water budgets for these two horizons indicate that uncontaminated, representative groundwater samples should be obtained. However, for at least three of the four locations chosen for sampling, the section selected fell outside the conducting horizons featured in the water budget calculations. Thus, taking into consideration the geological characteristics of the drillhole, this effectively means that portions of the borehole devoid of any significant conducting fractures were sampled for groundwater. The only suitable water source was the borehole itself, and the most likely origin of these waters is from those major conducting local fracture Zones identified by the hydraulic testing.

The water chemistry indicates two groundwater types:

- oxygenated, near-surface water
- non-saline, intermediate groundwater of a reducing character

In both cases the presence of iodine indicates a residual drilling water component. The presence of oxygenated, near-surface water at level 96-98 m is a function of the shallow depth of the sampling, combined with high conductivity and a positive piezometric head. The source of the water probably originates from higher-level conducting zones which have channelled some near-surface water (indicated by measurable tritium and containing small amounts of drilling water) into the borehole. This water has been subsequently leaked around the packer system during sampling. The remaining three sampling points are characterised by non-saline, intermediate groundwater which is uncontaminated by any younger water component (<3TU) and is greater than 12 000 years old; small amounts of residual drilling water are present. This groundwater source almost certainly originates from the highly conductive local fracture Zones 15 and 17. The high angle intersection of Zone 17 (85° with the bedrock surface), together with the intersection of Zone 15 with several local fracture zones at depth, would facilitate groundwater mixing and homogenizing from different sources and may have a bearing on the similar water chemistries obtained from these two potential sources. However, the available hydrological data suggests that level 376-378 m, close to the highly conductive Zone 17, is the most likely groundwater source which represents an intermediate non-saline type.

The dissolved uranium in groundwaters from the sampled levels show high contents for the uppermost oxidising horizon (3.47 ppb). At greater depths, and in accordance with the other chemical parameters, the uranium content is similar in the three remaining sampled groundwaters. Here, the low to negligible contents (<0.1-0.22 ppb) support a reducing groundwater environment. The ²³⁸U/²³⁴U activity ratios for the three deeper levels range from 3.3 to 4.5 which indicate substantial ²³⁴U excess, probably from alpha-recoil mechanisms and suggest fairly long residence times in the bedrock.

In Table 5.13 and Figure 5.47 the analytical uranium contents and the theoretically calculated uranium solubilities for both crystalline and amorphous UO_2 at a pH of 8.10 and 9.50 are presented and plotted as a function of Eh. The uppermost water sampled plots within the calculated stability boundaries for a pH of 8.10. The remaining three samples plot in and around the amorphous UO_2 stability curve at a pH of 9.50.

Table 5.13: Uranium content and theoretical Eh values of the groundwater from borehole Sv 4.

Level (metres)	Uranium Content (ppb)	Calculated Eh (mV)
96- 98	3.47	-129
376-378	0.22	-355
430-432	0.20	-285
630-632	0.15	-273

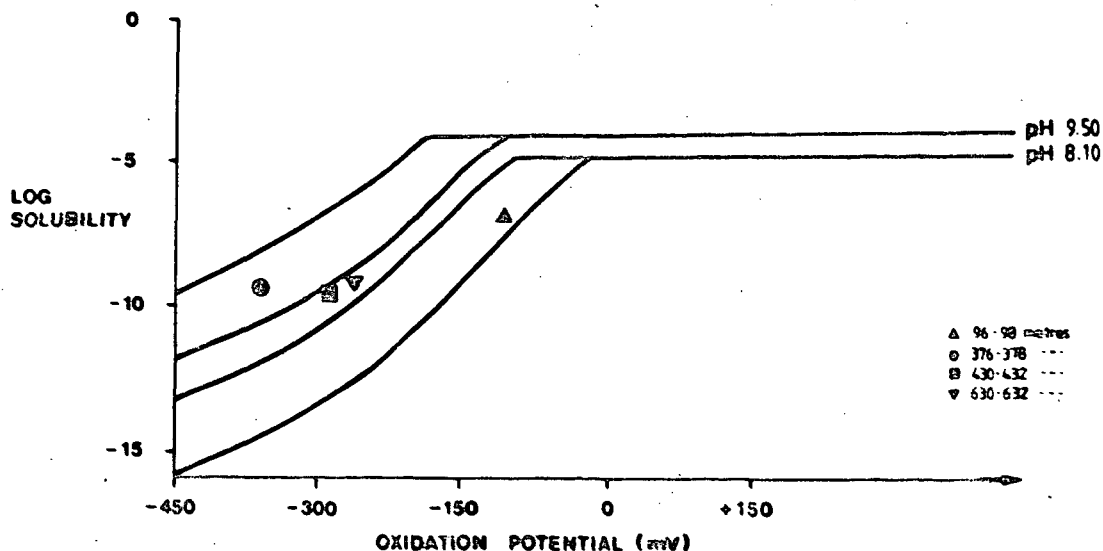

Figure 5.47: Plots of uranium content (expressed as log (mol/litre)) and the calculated theoretical Eh values of groundwaters collected from borehole Sv 4. The values are plotted with respect to theoretical uranium solubility curves calculated for amorphous (lower stability limit) and crystalline (upper stability limit) UO₂ at a pH of 9.50.

5.3.2 Borehole Sv 5

The borehole was drilled at 86° to a vertical depth of 799.50 m (borehole length 801.45 m) in order to:

- study the hydrogeological properties of the bedrock from a centrally-located deep borehole
- study a relatively fracture-free portion (as deduced from ground geophysical measurements) of the test-site area
- locate at depth the presence of possible local fracture zones as suggested from geophysical investigations
- estimate the extent of the migmatite

Resulting from the drilling a total of five major fracture zones were intersected; Zone 8 at 128-136 m, Zone 15 at 254-270 m, Zones 7 and 14 at 371-410 m, and Zone 18 at 727-737 m (see Figures 5.42 and 5.48).

The bedrock encountered comprised 71 % migmatite gneiss, 25 % granitic migmatite, and 3 % greenstone; percentages relate to borelength length. The migmatite is typically banded to veined in appearance, with more diffuse homogeneous thicknesses commonly present. Below 200 m a coarse veined gneiss with decimetre thick bands/veins tends to occur more frequently. The granitic bedrock variety is characterised by a coarse-grained, light-coloured pegmatitic quartz/feldspar type, and a grey-coloured, medium-grained, more homogeneous type. The former type is a typical migmatite granite which mostly occurs within the upper part of the borehole (0-500 m) as thin (<10 m) horizons fairly evenly distributed in the migmatite gneiss. The latter type is mostly present as greater thicknesses, e.g. 510-570 m, 605-670 m and 700-800 m, although of less frequent occurrence.

Greenstones (average thickness of 0.7 m) are often sheared and occur parallel to the regional structural trend. Certain dolerite varieties can be distinguished; these are present throughout the bedrock and have an average thickness of around 1 m.

The average fracture frequency/metre for the hole is 3.5. For individual rock-types, the greatest fracture frequency is recorded by the greenstone (9.0 fractures/m), followed by migmatite gneiss (3.8) and finally the migmatite granite (1.9). In general, fracture frequency decreases with depth with the greatest frequency occurring from 0-270 m, and the lowest frequency being present between 270-360 m and 400-700 m (i.e. less than 2 fractures/metre) (see Figure 5.49a).

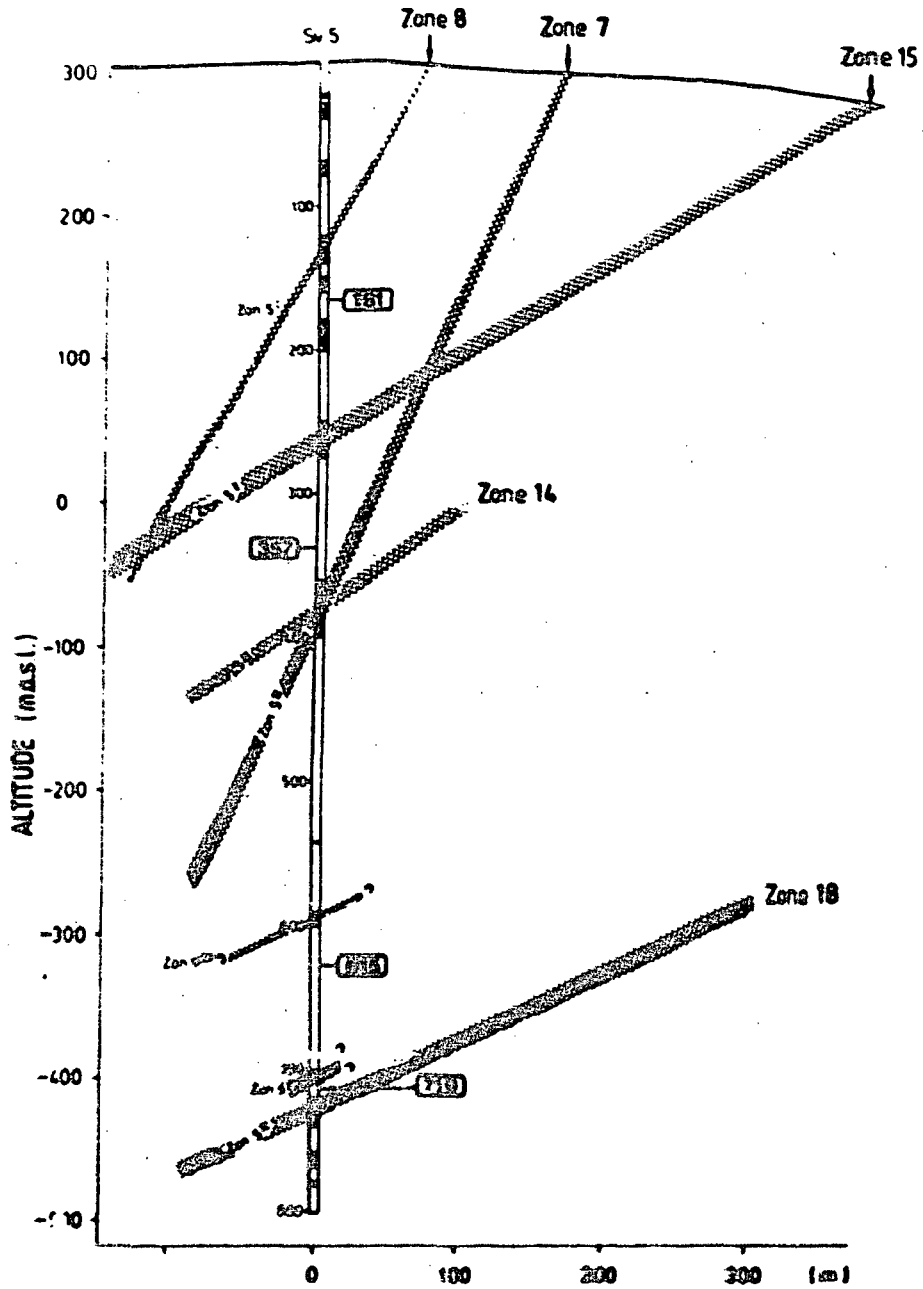

Figure 5:48 Location of the major fracture/crush zones and their relationship to the groundwater sampling horizons (Borehole Sw 5).

As mentioned above, a characteristic feature of the borehole is the presence of five major fracture zone intersections one of which (Zone 18) being of regional importance. These range in width from 5 to 15 m, and each comprise 8 to 14 fractures/m. These zones are moderately to steeply inclined to the borehole axis (30-80°) and the three shallower zones (i.e. Zones 8, 15 and 7/14) show evidence of widespread alteration due to weathering. The most common fracture/crush zone minerals are illite, chlorite and calcite with more minor amounts of other clay mineral phases and zeolites.

Hydrologically, because of the borehole location close to the summit of Svartboberget itself, groundwater recharging conditions prevail, most probably accompanied by a decrease of piezometric head with depth. The groundwater level in Sv 5 usually exceeds 10 m depth. The hydraulic conductivity measured along the hole roughly decreases with increasing depth apart from four sections at approximately 375, 500, 625 and 750 m. Two of these correspond to fracture zone intersections, i.e. Zone 7/14 at 371-401 m and Zone 18 at 727-737 m. Zone 18, which is regional in extent and delineates the eastern margin to the test-site, records an extremely high conductivity ($K = 3.0 \cdot 10^{-8}$ m/s) for this depth (Table 5.14a).

The piezometric head shows a rapid decrease to about 300 m depth; little variation occurs for a further 200 m whereupon an increase is recorded towards the hole bottom (Fig. 5.49c). The differences in piezometric head is greater than 50 metres of water and varies between 245 and 300 m.

Table 5.14a. Measured hydraulic parameters and calculated water budget values of the various influences due to borehole activities at the water sampled levels in borehole Sv 5.

Level (m hole length)	K-value ^a (m/s)	Head deviation ^b (m)	Flow direction (borehole trends)	Drilling water (+) (m ³)	Gas-lift pumping(-) (m ³)	Hydraulic testing (+) (m ³)	Open hole effect before sampling(±) (m ³)	Sampled water before analysis (-) (m ³)
161-163	1.9·10 ⁻⁸	+0.5	•	0.78	0.147	0.007	-0.82	1.6
357-359	3.0·10 ⁻⁸	-52.0	•	1.43	0.23	-0.001	+138.7	1.22
615-617	1.8·10 ⁻⁹	-45.5	•	0.043	0.014	0.001	+7.65	1.41
719-721	9.2·10 ⁻⁹	-30.5	•	0.10	0.072	0.004	+27.58	2.65

^a 25 m section; head deviation from hydrostatic head in the borehole (in metre of water).

Table 5.14b. Measured hydraulic parameters and calculated water budget values of the various influences due to borehole activities at the water sampled levels in borehole Sv 5.

Level (m hole length)	K-value ^a (m/s)	Head deviation ^b (m)	Flow direction (borehole trends)	Drilling water (+) (m ³)	Gas-lift pumping(-) (m ³)	Hydraulic testing (+) (m ³)	Open hole effect before sampling(±) (m ³)	Sampled water before analysis (-) (m ³)
161-163	1.9·10 ⁻⁸	+0.5	•	0.78	0.147	0.007	-0.82	1.6
357-359	3.0·10 ⁻⁸	-52.0	•	1.43	0.23	-0.001	+138.7	1.22
615-617	1.8·10 ⁻⁹	-45.5	•	0.043	0.014	0.001	+7.65	1.41
719-721	9.2·10 ⁻⁹	-30.5	•	0.10	0.072	0.004	+27.58	2.65

^a These values are calculated using the data from the 10 m sections. The values in all tables are the most representative for the geology of the site.

^b • indicates that the flow is from the borehole to the surrounding rock.

^c See Table 5.14a.

^d Figure 5.49 shows the representative

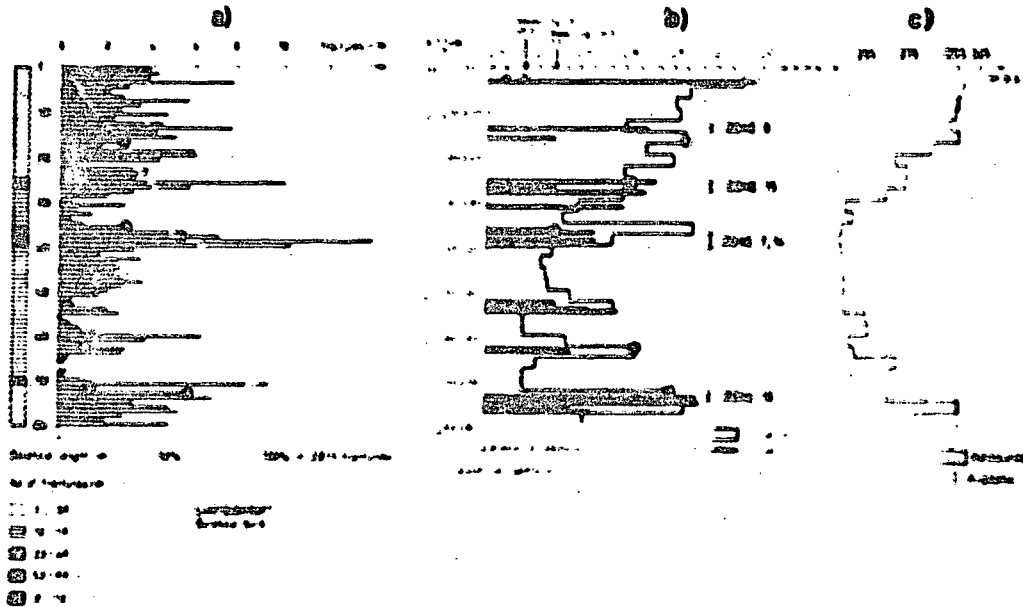

Figure 5.49: Hydrogeological characteristics of borehole Sv 5.
 a) Fracture frequency (for 10 m sections) and the cumulative percentage of fractures.
 b) Hydraulic conductivity.
 c) Piezometric head distribution and hydrostatic head in the borehole.

5.3.2.1 Level 161-163 m (approx, 160 m).

The sampled section is characterised by uniformly-grained biotite quartz gneiss containing veining of a coarser, pegmatitic material, which is structurally foliated along the regional trend. The borehole section contains two fracture zones varying in width from 10-25 cm and each comprising 4 fractures. In addition, two single fractures occur; the various fractures intersect the axis of the core at angles ranging from 20-90°, and all show signs of weathering.

Hydrology

This level is located within the highly conductive upper part of the borehole, and records a conductivity value of $1.9 \cdot 10^{-8}$ m/s and a head deviation of ± 0.5 m (Table 5.14 a). This results in a negative water budget (i.e. all contaminating water should be theoretically removed) even prior to sampling (Fig. 5.50). It is remarkable that the most fractured part of the 25 m section (approx. 155-158 m), tested more specifically along a 5 m section, records a hydraulic conductivity below the measuring limit (i.e. $< 2.5 \cdot 10^{-11}$ m/s).

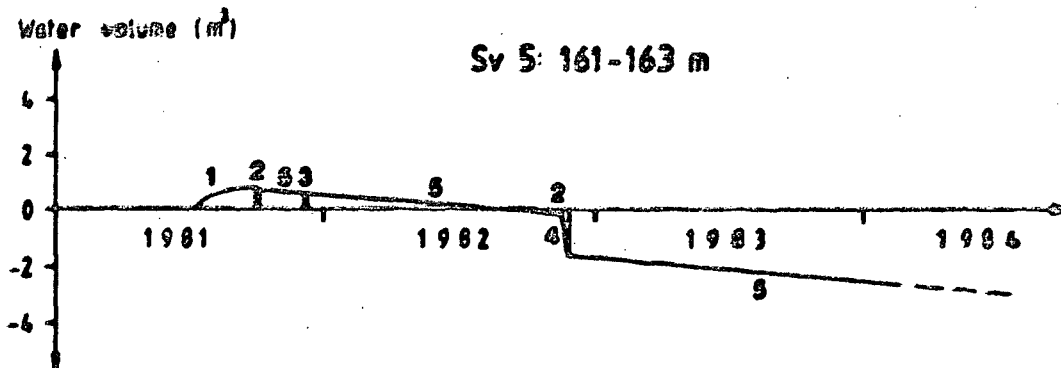

Figure 5.50: Schematic illustration of the calculated water budget for level 161-163 m in borehole Sv 5 (Svartberget). 1 = Drilling water; 2 = Gas-lift pumping; 3 = Hydraulic testing; 4 = Sampling; 5 = Open-hole effect.

Water geochemistry

A laboratory pH value of 7.7 was recorded (Table 5.14b). The major cations, Na^+ and Ca^{2+} , and the anions, HCO_3^- and Cl^- , are present in amounts which, although lower than expected for this level, still fall within the range of shallow, non-saline groundwaters. The presence of 2.4 % I^- indicates a sizeable drilling water component.

Redox-sensitive parameters

The stable isotope data ($\delta^{18}\text{O} = -12.8$ ppt and $\delta^2\text{H} = -92.2$ ppt) is representative for a meteoric water origin (Fig. 5.6). The tritium content (33 TU) indicates a major near-surface component; no ^{14}C data are available.

Uranium geochemistry

The oxidising groundwater environment indicated by the redox-sensitive parameters is further supported by very high dissolved uranium contents (40.19-44.5 ppb). An $^{234}\text{U}/^{238}\text{U}$ activity ratio of 2.1 indicates isotopic disequilibrium in the groundwater.

Summary

From hydrological considerations, the sampled groundwater should be free from all major sources of water contamination and therefore representative for the investigated level. However, the hydrochemical results show that:

- there exists a sizeable drilling water component
- there exists a major near-surface component
- some of the sampled water comprises a non-saline component which would be expected from such a level

The discrepancy between the predicted result and that obtained is due to the location of the sampling section within a relatively conductive part of the borehole, also characterised by a marginally positive piezometric head. In the largely recharging environment around the borehole, groundwater flow in this highly fractured upper section of the bedrock will therefore be strongly downwards, resulting in the availability of younger, near-surface derived water within and in the near vicinity of the borehole. This effect will be particularly emphasised during pumping for sampling purposes, resulting in the mixing of representative groundwaters for the sampled level with younger water from shallower sources. Furthermore, because of the very conductive/fractured character of the upper bedrock horizon, there will be an extremely high drilling water loss resulting in groundwater contamination for a considerable radius around the borehole. The presence of a sizeable drilling water component in the sampled water is therefore not surprising.

5.3.2.2 Level 357-359 m (approx. 356 m).

The dominating rock-type in this section is a grey-coloured, inhomogeneous gneiss with veining and fine banding of quartzitic material sometimes containing large sporadic feldspar grains; aggregates of garnet also occur.

Structurally, the section comprises one fracture zone (40 cm wide and containing 7 fractures) and four single fractures; fracture intersection with the axis of the core ranges from 15-80° and the main fracture filling minerals are calcite, together with unidentified mafic and non-mafic phases. Local fracture zones 7/14 are located approximately 10 m below the sampled level.

Hydrology

The 25 m borehole section containing the sampled length (which excludes Zones 7/14) records a hydraulic conductivity of $3.0 \cdot 10^{-8}$ m/s (Table 5.14a). Two 5 m sections within the 25 m section, which are located close to these fracture zones, show rather a low conductivity, i.e. the most hydraulically conductive part of the 25 m section appears to be furthest from these local fracture zones. With respect to the actual section sampled for groundwater, the one detailed water injection test, which included the sampled horizon, showed a K-value below the measuring limit. This effectively means that the water budget illustrated in Figure 5.51 is not representative.

Water geochemistry

For such a sampling depth the recorded laboratory pH value of 6.2 is unusually low (Table 5.14b) and more typical for surface to near-surface waters. This is further supported by the major ions (3 mg/l Na^+ ; 8 mg/l Ca^{2+} ; 28 mg/l HCO_3^- ; 8 mg/l Cl^-) which are lower than would be expected for groundwaters of an intermediate, non-saline nature. The virtual absence of a drilling water component is indicated by a low I-content (0.2 %).

Redox-sensitive parameters

A highly oxidising groundwater environment is indicated by a positive Eh (+275 mV), an absence of S(-II), and a high O_2 content of 2.75 mg/l. In contrast, the Fe (II) content is high (4.1 mg/l) which is not readily explained.

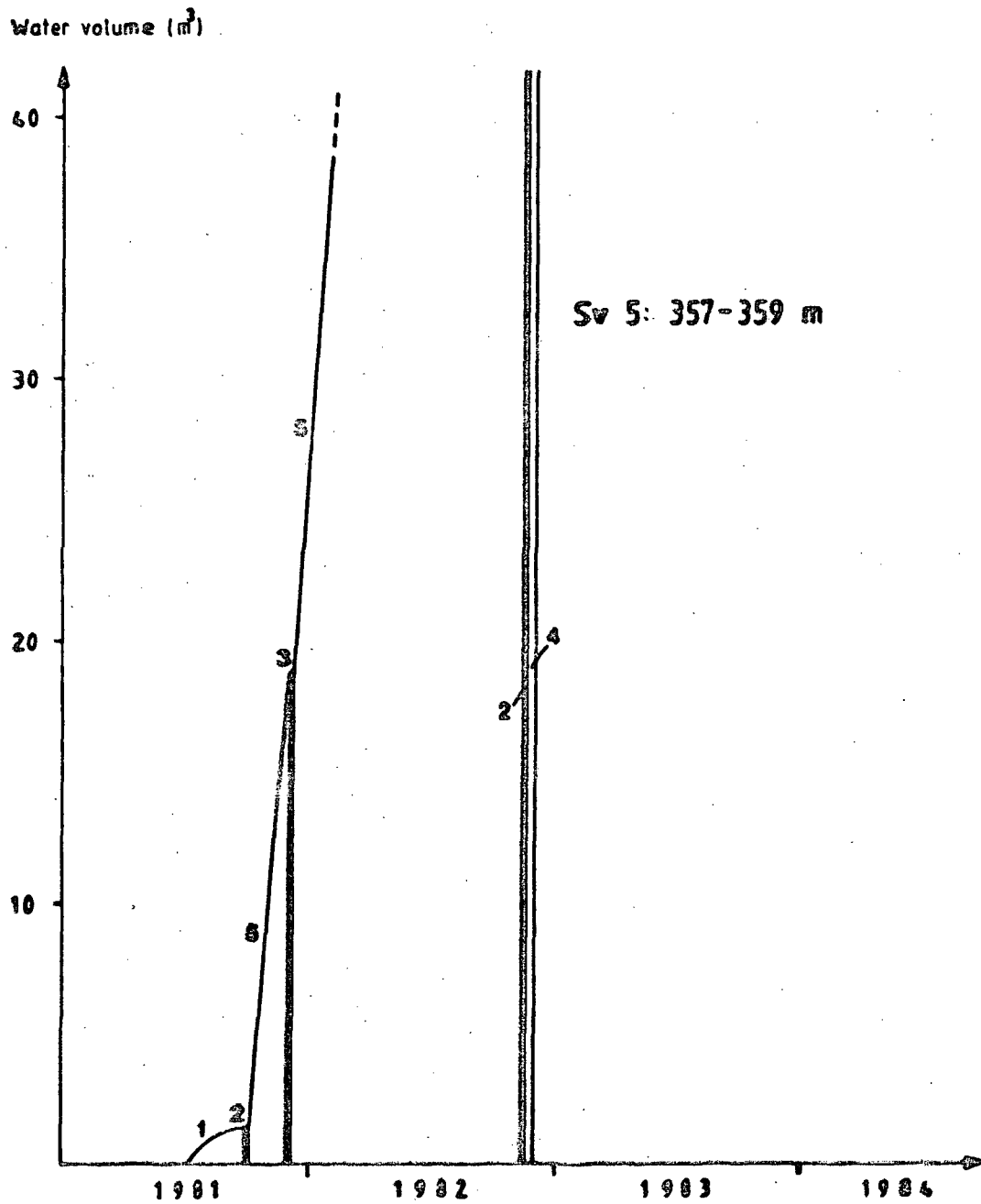

Figure 5.51: Schematic illustration of the calculated water budget for level 357-359 m in borehole Sv 5 (Svarthoberget). 1 = Drilling water; 2 = Gas-lift pumping; 3 = Hydraulic testing; 4 = Sampling; 5 = Open-hole effect.

Isotope geochemistry

The $\delta^{18}\text{O}$ value of -12.60 ppt indicates a meteoric origin; no deuterium data are available. The tritium content is very high (36 TU) and strongly suggestive of surface water. A similar source is supported by the ^{14}C data which indicates a very young water (285 years).

Uranium geochemistry

The dissolved uranium content is very low (<0.01-0.2 ppb); isotopic disequilibrium is shown by a $^{234}\text{U}/^{238}\text{U}$ activity ratio of 2.6.

Summary

As illustrated by the hydrological data, the selected borehole section for sampling is located below the dominating conductive horizon within the 25 m section. Thus, the illustrated water budget in Figure 5.51 is representative for the horizon rather than for the sampled section. The hydrochemical data points strongly to a young surface origin to the water sampled, which can only have originated from the borehole above the packed-off section. This is also plausible from the hydrogeological measurements which show that the combination of high conductivity and positive piezometric head occurs most convincingly in the very uppermost part of the borehole, where the dominant water source is young. The resulting downward transport of water is further accentuated by the very low piezometric heads in combination with significant K-values from 200 to 700 m, which results in the flow penetration of young water into the bedrock.

5.3.2.3 Level 615-617 m (approx. 614 m).

This level is located in a massive grey granite which is weakly foliated, uniformly fine-grained, and sometimes containing garnet. The drillcore section is characterised by only two single fractures which intersect the axis of the core at 30° and 75° respectively; calcite is the only recorded fracture mineral.

Hydrology

The sampled borehole length forms part of a 25 m section which records a higher conductivity ($1.8 \cdot 10^{-9}$ m/s) than the respective adjacent shallower and deeper borehole lengths: the hydraulic head is -45.5 m (Table 5.14.a). The water budget illustrated in Figure 5.52 shows that the water sampled should be 100 % composed of contaminating water from the borehole. Although calculated from the 25 m section, the water budget may be representative for the sampled section. This is supported by the fact that the two 5 m sections tested, which included the most fractured portions of the 25 m section, still recorded low conductivity values (Fig 5.49b).

Water chemistry

Similar to the preceding level (Table 5.14b).

Redox-sensitive parameters

Similar in properties to the preceding level.

Isotope geochemistry

Similar in properties to the preceding level.

Uranium geochemistry

Similar to the preceding level.

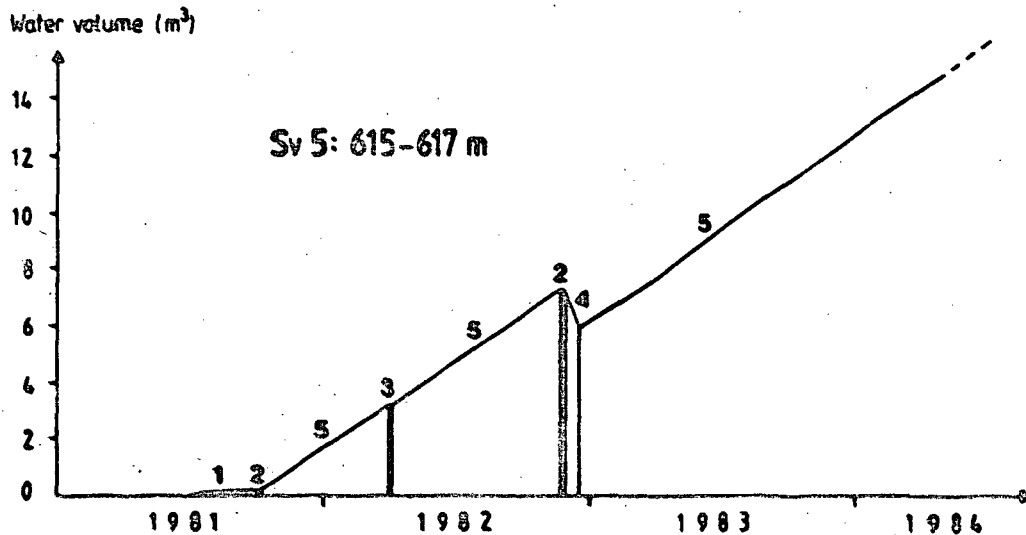

Figure 5.52: Schematic illustration of the calculated water budget for level 615-617 m in borehole Sv 5 (Svartboberget). 1 = Drilling water; 2 = Gas-lift pumping; 3 = Hydraulic testing; 4 = Sampling; 5 = Open-hole effect.

Summary

The hydraulic characteristics of the sampled level and the immediately adjacent borehole lengths show that the hydraulic conductivity is generally moderate and the piezometric head markedly negative. Geologically, the selected level for sampling is located in one of the least promising sections which is characterised by only two single fractures. The calculated water budget is therefore considered possible for the section sampled and this would indicate that the water collected is highly contaminated and originates from the borehole having been leaked past the packers during pumping. Contaminating borehole water is supported by the hydrochemistry which points to a young, near-surface derived, highly oxidising water of similar origin to that described from the preceding level.

5.3.2.4 Level 719-721 m (Approx. 718 m).

This level is characterised by three distinct rock-types; veined gneiss, greenstone horizon (55 cm wide), and migmatite granite. Structurally, there exists one fracture zone within the greenstone (30 cm wide and containing 5 fractures); four single fractures characterise the remainder of the core. Angles of intersection with the core axis vary from 30-80°, and the main filling minerals consist of calcite together with unidentified phases of mafic- and iron-mafic-rich composition. Located some 10 m below the sampled horizon is the regional fracture/crush Zone 18.

Hydrology

The very high hydraulic conductivity of the 25 m section corresponds to the regional fracture Zone 18, which has been tested along two 5 m sections. It is thus very doubtful whether the horizon sampled is water-conducting or is to any marked extent influenced by the open hole effect as illustrated in Figure 5.53.

Water geochemistry

Similar to the previous two levels apart from a much higher I⁻ content (4.7 %) indicating a significant drilling water component (Table 5.14b).

Redox-sensitive parameters

Similar to the previous two levels in that a markedly oxidising groundwater environment is indicated.

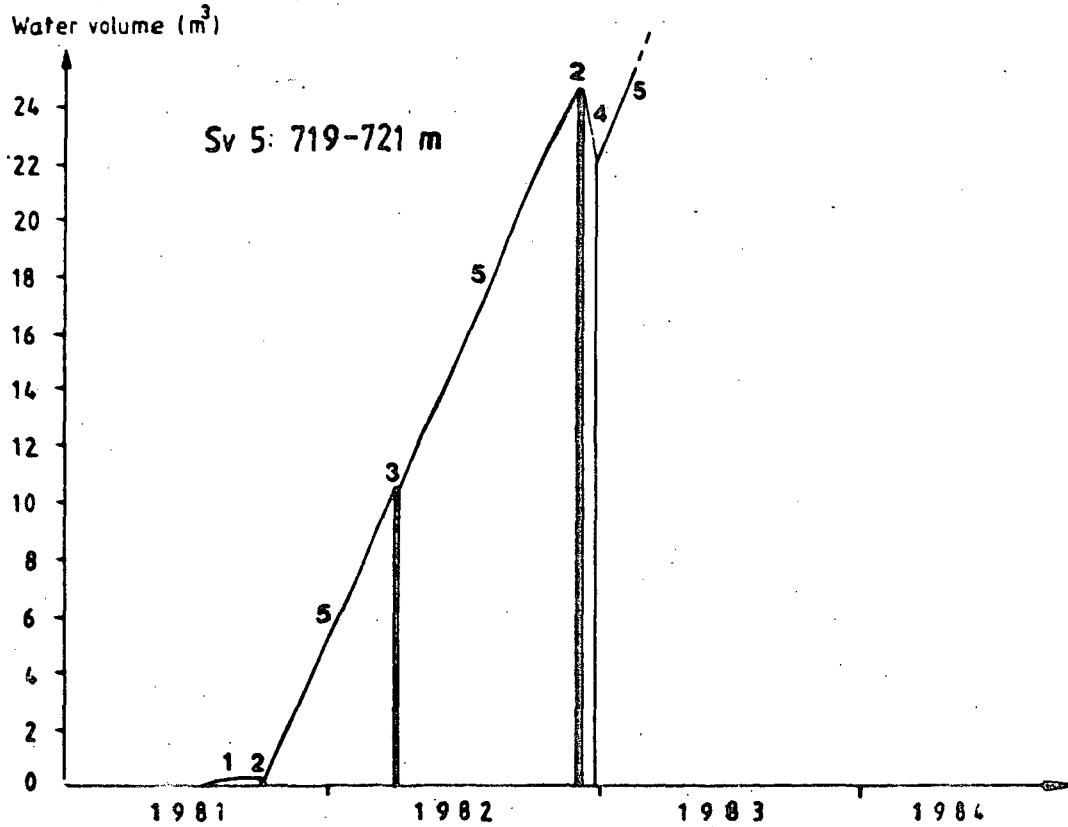

Figure 5.53: Schematic illustration of the calculated water budget for level 719-721 m in borehole Sv 5 (Svartboberget). 1 = Drilling water; 2 = Gas-lift pumping; 3 = Hydraulic testing; 4 = Sampling; 5 = Open-hole effect.

Isotope geochemistry

Similar to the two previous levels in that a young, near-surface to surface water, characterises the collected sample.

Uranium geochemistry

The limited data that are available indicate very low levels of dissolved uranium.

Summary

Because of the dominating influence of Zone 18 located some 10 metres below the sampled horizon, the illustrated water budget is not representative for the sampled level. Some limited groundwater may be expected from the fractured greenstone contained within the packed-off section. However, the hydrochemical data, in common with the previous two levels, indicate a young, near-surface to surface water which is significantly oxidising in character. The source of the water is similar to that of the two previous levels.

5.3.2.5 Borehole summary and discussion

Borehole Sv 5 was drilled to characterise the general hydrological, geological, and hydrochemical characteristics of the bedrock from a central location in the Svartboberget test-site area. The dominating bedrock is a migmatite gneiss with subordinate migmatite granite and greenstone/dolerite. At depth, several large-scale fracture/crush zones were intercepted, the deepest of which (Zone 18) being of regional scale. All of these zones are considered to intercept the bedrock surface to the east of the test-site area and all have a general strike of NW-SE.

Because of the topographic location of Sv 5 close to the highest point of the area, the local hydrological conditions are considered recharging, probably accompanied by a decrease of piezometric head with depth. The measured hydraulic conductivity along the hole decreases with depth apart from four sections, two of which correspond to local fracture zones 7/14 and the regional fracture Zone 18 (Fig. 5.49b). The latter records an extremely high conductivity ($3.0 \cdot 10^{-8}$ m/s) for such a depth (727-737 m).

With the exception of the uppermost sampled level (161-163 m), all other water budget calculations for the 25 m borehole sections indicate waters which are highly contaminated and therefore non-representative. The major cause of contamination is due to open-hole effects which result from medium to high hydraulic conductivities combined with strongly negative piezometric heads. To further complicate the situation, not only are the sampled groundwaters not representative for the bedrock depths investigated, but they are not even a product of the packed off sections. For the lower three sampled levels, the sections selected fell outside the conducting horizons featured in the water budget calculations. The groundwater samples must therefore have been leaked past the packer system from the borehole most likely via a short-circuiting network of fractures.

The hydrochemical data identify two groundwater types:

- surface to near-surface oxidising water
- intermediate to shallow non-saline groundwater

The second groundwater type is present only within the uppermost level, and even then in a much diluted form resulting from mixing with surface to near-surface water and drilling water. In general the dominating water sampled from all the levels is characterised by the first type. There is no doubt that the waters sampled are surface to near-surface in origin. The question is whether they represent water in the borehole above the packer system, or water removed from nearby fractured conductive horizons which has collected as a result of open-hole effects?. Because of the prevailing hydrological conditions in the borehole (i.e. conductive and positive heads), waters derived from the uppermost 100 m of the borehole will not surprisingly penetrate to depth and into the bedrock were strong negative heads and marked conductivities are indicated. It is thus proposed that the waters sampled have their origin from the uppermost part of the borehole. In the case of the

uppermost level, some mixing with bedrock groundwater has occurred facilitated by the high hydraulic conductivity and positive head. The next two levels are characterized only by waters of surface origin which is in part supported by an almost complete absence of iodine tracer. The lowermost level sampled represents again mostly surface-derived water although the presence of iodine tracer (4.7 %) might suggest some mixing with drilling water from the major fracture Zone 18.

It is noticeable that the three deepest levels record high Fe (II) contents (4.1-11.0 mg/l). This may be the result of reaction in the borehole between the metal pipes and the downward penetrating oxidising waters.

Because of the non-representative character of the sampled waters, interpretation of any uranium trends is meaningless. The very high uranium contents from the uppermost level (40.19-64.5 ppb) is further support that some of the sampled water has originated in the bedrock, and that the groundwaters have been sufficiently oxidising to accommodate so much uranium in solution. In contrast the very low contents from the other levels are typical of highly oxidising surface water which has had minimum contact with the bedrock. In Table 5.15 and Figure 5.54 the analytical uranium contents and the theoretically calculated uranium solubilities for both crystalline and amorphous UO_2 at a pH of 6.20 are presented and plotted as a function of Eh. All water compositions plot within the amorphous stability field.

Table 5.15: Uranium content and theoretical Eh values of the groundwater from borehole Sv 5.

Level (metres)	Uranium Content (ppb)	Calculated Eh (mV)
161-163	44.5	+292
357-359	0.23	+179
615-617	0.15	+216
719-721	0.20	+ 75

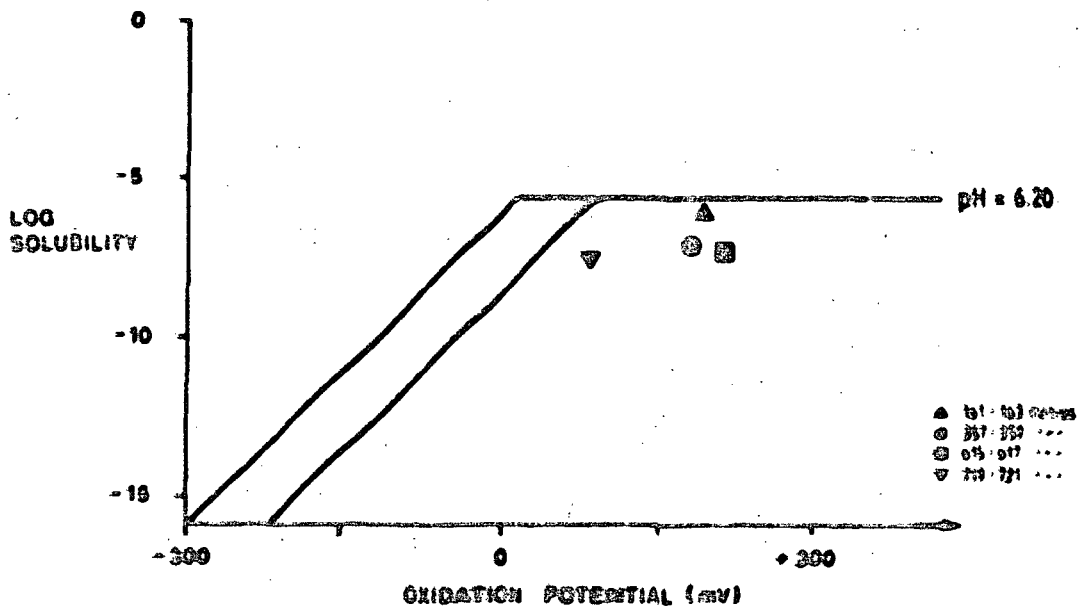

Figure 5.54: Plots of uranium content (expressed as log (mol/litre)) and the calculated theoretical Eh values of groundwaters collected from borehole Sv 5. The values are plotted with respect to theoretical uranium solubility curves calculated for amorphous (lower stability limit) and crystalline (upper stability limit) UO_2 at a pH of 6.20.

5.4 Kamlunge

The Kamlunge test-site is situated in northern Sweden about 35 km from the Baltic coast (Fig. 1). In common with the other described areas, Kamlunge represents a crystalline rock environment which is Precambrian in age. Topographically the region forms a plateau with a ground level range of 40 to 175 m above sea-level (Fig 5.55); ice-movement has imposed a dominant NNW - SSE orientation on the local topographic features. The plateau may be described as a horst-type feature, a triangular block some 16 km² in area, bounded on three sides by large-scale regional lineaments which are presumed to be near vertical in penetration. Outcrop exposure is generally good, otherwise a thin to moderate moraine cover is usual (approx. 5-10 m).

The regional geology of the area has been described generally by Önan (1957) and Lundqvist (1979). As a result of SKB investigations between 1981-83 the area has recently been described in more detail by Albino et al (1983) and summarised by Ahlborn et al (1983e). The region is characterised by metamorphic and migmatitic rocks which are Precambrian in age; the region is regarded as having been relatively stable for long periods of geological time. Briefly, the oldest rocks in the area are basement Archean granite gneisses. In Finland and further north in Sweden, similar basement rocks reveal ages ranging from 2600-2800 Ma (Melin et al, 1971; Perttunen, 1980). Overlying and disconformable with the Archean basement are the younger Svecofennian rock groups. The Svecofennian is initially represented by metasediments and metavolcanics. These are followed by the Haparanda series of deep intrusives comprising granodiorite and gabbro which have been dated by Rb-Sr to around 1840 Ma (Melin et al, 1970). The earlier metasediments and metavolcanics are thus considered to be within the range of 1900-2500 Ma. Metamorphism in the region culminated during the Svecofennian epoch at approximately 1800 Ma resulting in widespread

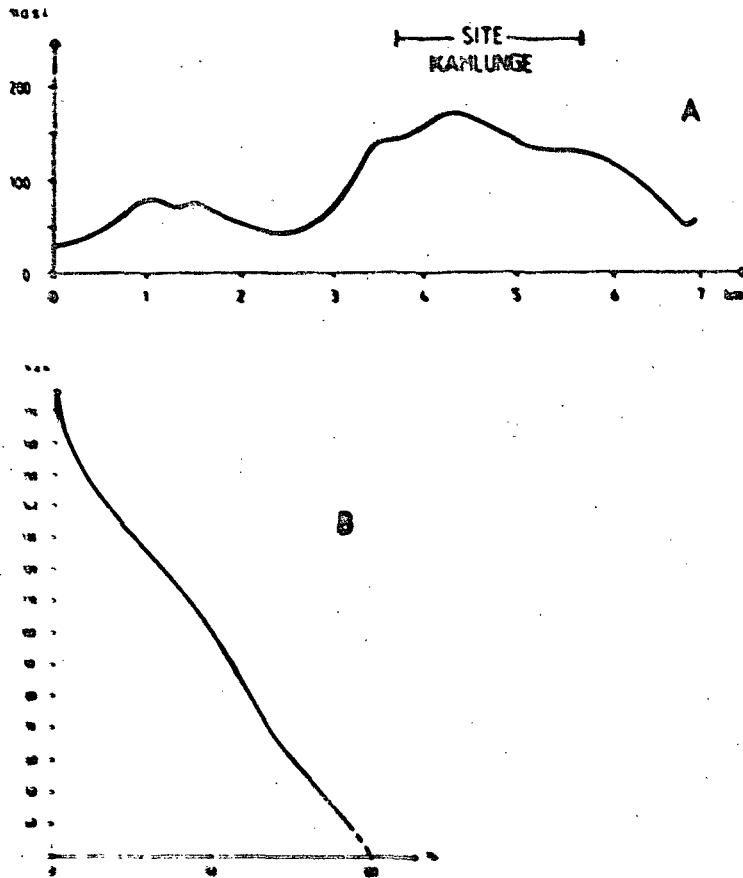

Figure 5.55: The Kamlunga test-site. A: Topographic profile across the site; B: Hypsographic curve showing altitude characteristics.

migmatization. Coeval with metamorphism, and forming large-scale intrusions in the region, is the Lina granite which indicated a range of Rb-Sr ages from 1565-1800 Ma (Melin et al, 1970).

The oldest rocks exposed at the Kamlunga test-site area are the above mentioned metasediments and metavolcanics. These are present as quartzitic gneiss, biotite gneiss and amphibolite which are later intruded by granodiorite and gabbro of the Haparanda series. The Lina granite, with widespread pegmatitic activity, intrudes all older rock types.

Large-scale lineaments measured in an area of approximately 600 km² around Kamlunge revealed three main groups characterised by orientation. The most important group was orientated parallel to the dominant ice-movement direction (N40W-S40E); the remaining more minor trends were N10E-S10W and N30E-S30W respectively. Detailed fault and joint patterns have been measured from the exposed bedrock at the Kamlunge test-site. Local fracture zones have been indicated by different geophysical methods, and have suggested the presence of seven zones ranging in width from less than 5 m to 15 m which traverse the test-site area (Fig 5.56).

The properties of these fracture zones at depth have been investigated by means of 16 core drillholes (to a maximum depth of 650 m) and 21 percussion drillholes (0-150 m depth); the zones tend to be steeply inclined and spaced about 500-1500 m apart. In addition, a horizontal fracture zone was penetrated at a depth of 550 m. This zone, which was water conducting, varied in width from 4 to 14 m and is less weathered and crushed than the steeply inclined fracture zones.

Fracturing of the bedrock mass has been mapped on surface outcrops and on drillcores. The fractures on the surface have a dominant W-NW orientation which is largely perpendicular to the direction of the regional foliation. In the gneisses the fracture frequency averages 1.3 fractures/metre whilst the dioritic, granodioritic and granitic rock-types are characterised by 1.1 fractures/metre.

In relation to depth the greatest fracture frequency (4 fractures/metre) is encountered in the uppermost 200 m. At greater depths an average of 2.5 fractures/metre is usual. In common with the other areas it is important to note that the higher fracture frequency of the drillcores compared with the outcrop measurements is due to the fact that the frequency of horizontal fractures is underestimated in the outcrop mapping. Moreover, the

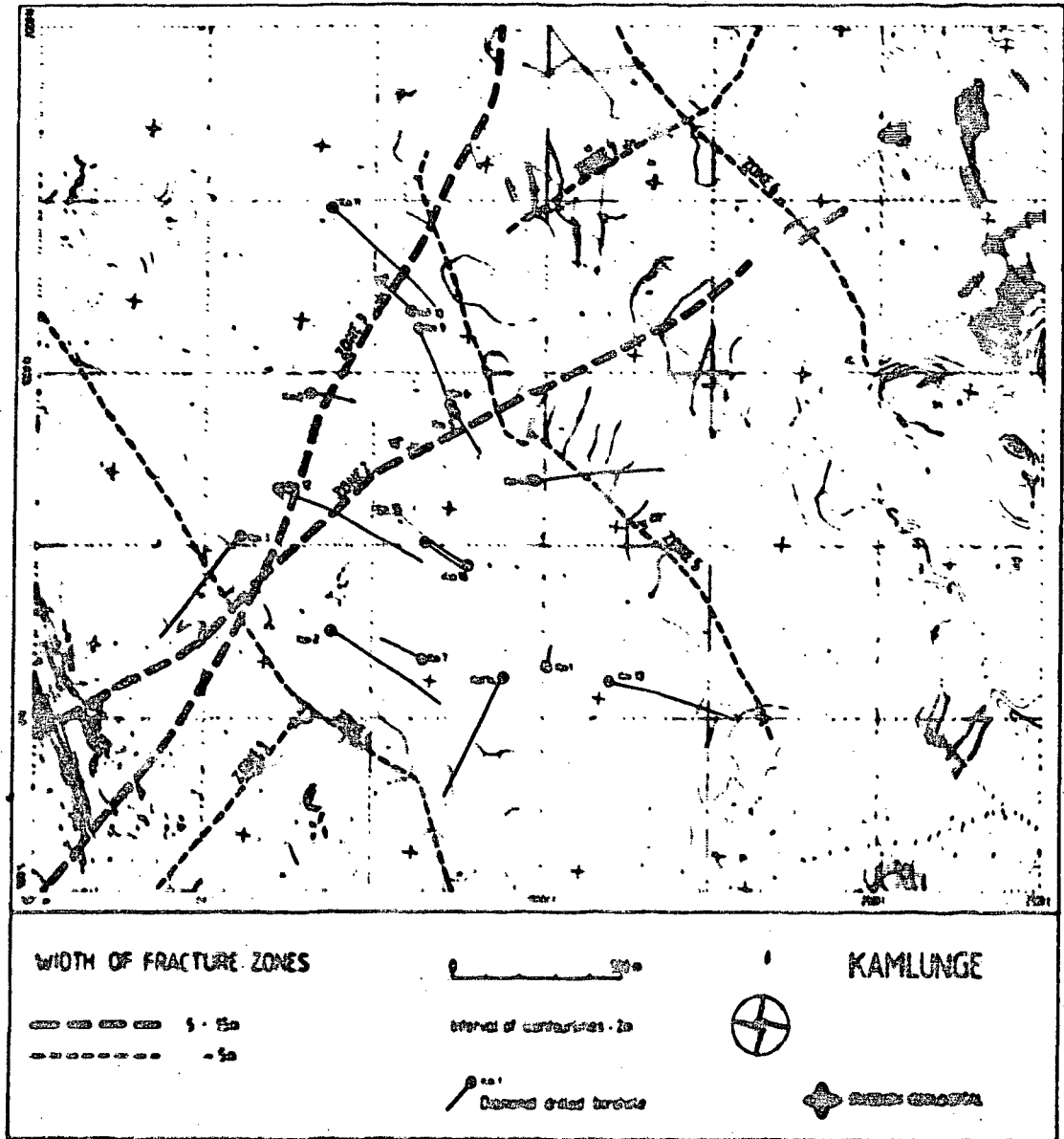

Figure 5.56: Topographic map of the Kamlunge test-site area showing the main structural zones of weakness and the location of the 14 (Km 1 to Km 14) cored boreholes.

fracture frequency of the drillcores include all fractures regardless of length, whereas the outcrop mapping does not include fractures shorter than 0.5 m.

Regardless of depth the total fracture frequency for different rock-types is greatest for the amphibolite (4.7), followed by granodiorite (4.0), quartzitic gneiss (3.9) and lastly the biotite gneiss (3.6). The highest fracture frequency has been recorded for an ultrabasic rock only found in one borehole. The most commonly occurring fracture filling mineral phases include chlorite, calcite and zeolites with subordinate sulphide minerals. Many of the local fracture zones (and others of lesser dimensions) are often characterised by coatings of iron oxides which include hematite and goethite.

Hydrologically the Kamunge test-site is situated on a ridge which constitutes the water divide between the Kalix river catchment area to the west and the Sangis river catchment area to the east. These areas are about 23 000 km² and 600 km² respectively and the rivers eventually flow into the Baltic sea. The major part of the investigated region is drained by the Korpikån stream which forms part of the Sangis catchment area.

Since Kamunge is a plateau the site as a whole can be regarded as a recharge area. Minor discharge areas occur in low-lying regions usually evident as expanses of marsh or peat bog; additional discharge occurs along the steep western slopes of the plateau resulting in several lakes.

The annual fluctuation in groundwater recharge and storage in the Kamunge area is typical for coastline regions of northern Sweden. Two periods of recharge occur, one in late Spring and the other in the Autumn. The former coincides with snow melting and the latter with moderate to heavy precipitation, in combination with low evaporation rates. The minimum and maximum groundwater levels occur just prior to and just after snow melting.

The mean groundwater temperature in this region is 3.5° to 4.0°C, i.e. some degrees above the annual mean air temperature. This is due to the absence of any recharge in the Winter in combination with the insulation effect of the snow cover (Knutsson and Fagerlind, 1977).

The groundwater table level is in general 1 to 3 m below the surface; this depth can vary up to more than 10 m along slopes and under isolated topographic high spots. As with the other areas described the morphology of the groundwater table reflects on a smoother scale the topographic relief of the area. The groundwater gradients are relatively small along the top of the plateau and considerably greater at the plateau boundaries, especially at the western margin. The altitude of the groundwater table varies between 135 and 165 m above sea-level.

The water balance of the Kamlunga test-site during the period 1951-1980 has been calculated to:

Adjusted precipitation	690 ± 25 mm/year
Actual evaporation	350 ± 25 mm/year
Run-off	330 ± 10 mm/year

The discrepancy between run-off and available precipitation (i.e. evaporation less precipitation) is probably due to the uncertainty in these recorded values. The groundwater run-off through the boundaries of the area is supposed to be negligible. From the numerical modelling by Carlsson et al (1983) the groundwater recharge to the bedrock has been calculated to be approx. 2 mm/ year.

5.4.1 Borehole Km 3

Borehole Km 3 was drilled at 60° to a vertical depth of approx. 585 m (borehole length of 700.15 m) in order to: 1) investigate the bedrock comprising the steep western edge of the plateau and 2) to locate at depth the presence of local fracture Zone 4 (see Fig 5.56). As a result Zone 4 was located at 504 - 517 m; in addition, Zone 2 was intercepted at 313 - 337 m and Zone 3 at 441 - 450 m.

In terms of rock composition, the dominant rock-type in the borehole is granodiorite (42.9 length %), followed by granite/pegmatite (25.3 length %), amphibolite (22.2 length %) and lastly biotite gneiss (9.6 length %). With regard to fracture density, granodiorite recorded 4.94 fractures/metre, granite 4.76, amphibolite 4.32, and biotite gneiss 3.54. In general, pegmatite horizons are most fractured. Related to depth the fracture frequency is greatest in the uppermost 200 m, with more than 4 fractures/metre (i.e. area of stress-release fracturing). Effective porosity measurements of individual rock units (S. Sehlstedt, 1983, per. commun.) show a general low porosity (<0.3 %). However, significant differences do exist between the different rock units, for example, amphibolite (mean 0.26 %) records slightly higher values than biotite gneiss (mean 0.23 %) and granite/pegmatite (mean 0.22 %) but significantly higher than granodiorite (mean 0.13 %).

The fracture minerals that most commonly characterise the drillcore are chlorite, calcite +zeolite, iron-oxides such as hematite and goethite, and more rarely sulphides.

The location of the borehole along the steep western slope of the Kamunge plateau and its general orientation downslope, will result in high hydraulic gradients. In fact, the head difference in Km 3 between the bedrock surface and the borehole bottom exceeds 20 m of water according to the numerical modelling of the overall

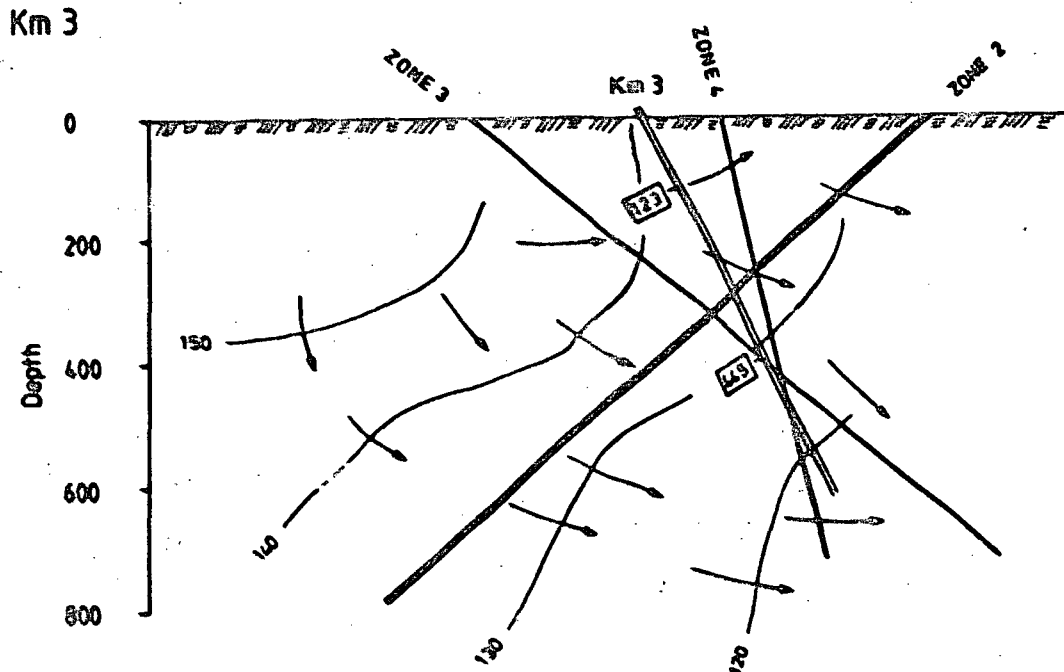

Figure 5.57: The groundwater flow-pattern and isopotentials in the vicinity of borehole Km 3 illustrated by a vertical section in the same plane as the direction of the borehole (modified after the numerical modelling of the Kenakta Consulting Co).

groundwater flow patterns at Kamlunga (Carlsson et al. 1983; Fig 5.57). The general feature of the groundwater flow in the vicinity of borehole Km 3, which is considerably influenced by the complex geometry of the nearby local fracture zones (Zones 1, 2 and 3; Fig 5.56), is a flow directed towards the regional lineament demarcating the western edge of the plateau. In the uppermost bedrock horizon near Km 3 a local groundwater circulation cell can be recognised. At greater depths the flow direction becomes more vertical, eventually extending to a more regional circulation.

The calculated head distribution from the groundwater model bears no similarity to the measured data from the borehole (Fig 5.58). Unfortunately there is a lack of data from below 300 m due to the fact that low K-values

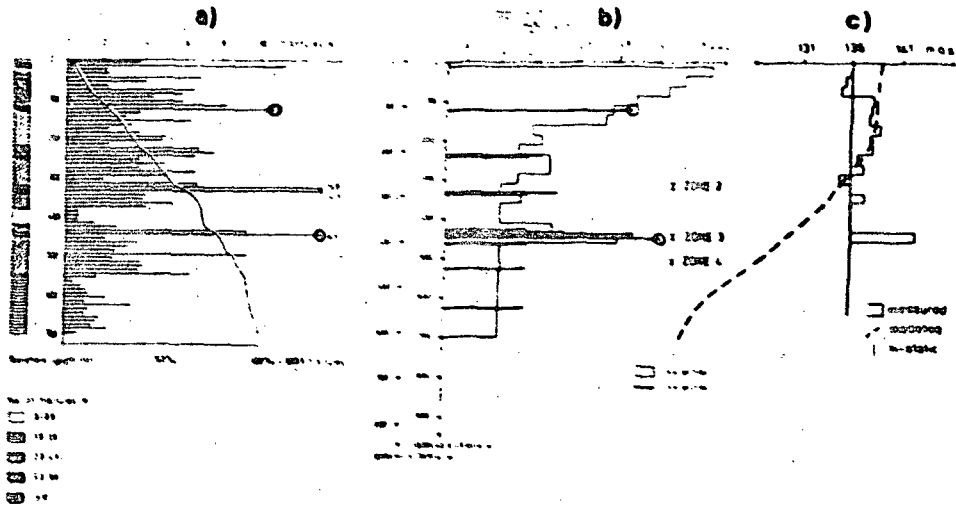

Figure 5.58: Hydrogeological characteristics of borehole Km 3.
 a) Fracture frequency (for 10 m sections) and the cumulative percentage of fractures.
 b) Hydraulic conductivity
 c) Piezometric head distributions and hydrostatic head in the borehole.

Table 5.16a Measured hydraulic parameters and calculated water budget values of the various influences due to bore-hole activities at the water sampled levels in borehole Km 3.

Level (to hole level)	K-value ^a (m/s)	Head deviation (b) (m)	Flow direction (borehole is inside)	Drilling water (+) (m ³)	Gas-lift pumping (-) (m ³)	Hydraulic testing (+) (m ³)	Open hole effect before sampling (±) (m ³)	Sampled water before analysis (-) (m ³)
113-123	$7.1 \cdot 10^{-9}$	+7.1	*	0.32	0.006	0.009	+0.564	0.0
123-127	$1.0 \cdot 10^{-8}$	+0.3	†	0.20	0.009	0.050	-1.54	0.2

^a 1) sectionally head deviation from hydrostatic head in the borehole (in units of water)

Table 5.16b Some data on water parameters of groundwater sampled from the left borehole Km 3 (center)

Level	157-160 m	160-163 m	163-166 m	166-169 m	169-172 m	172-175 m	175-178 m	178-181 m	181-184 m	184-187 m	187-190 m	190-193 m	193-196 m	196-199 m	199-202 m	202-205 m	205-208 m	208-211 m	211-214 m	214-217 m	217-220 m	220-223 m	223-226 m	226-229 m	229-232 m	232-235 m	235-238 m	238-241 m	241-244 m	244-247 m	247-250 m	250-253 m	253-256 m	256-259 m	259-262 m	262-265 m	265-268 m	268-271 m	271-274 m	274-277 m	277-280 m	280-283 m	283-286 m	286-289 m	289-292 m	292-295 m	295-298 m	298-301 m	301-304 m	304-307 m	307-310 m	310-313 m	313-316 m	316-319 m	319-322 m	322-325 m	325-328 m	328-331 m	331-334 m	334-337 m	337-340 m	340-343 m	343-346 m	346-349 m	349-352 m	352-355 m	355-358 m	358-361 m	361-364 m	364-367 m	367-370 m	370-373 m	373-376 m	376-379 m	379-382 m	382-385 m	385-388 m	388-391 m	391-394 m	394-397 m	397-400 m	400-403 m	403-406 m	406-409 m	409-412 m	412-415 m	415-418 m	418-421 m	421-424 m	424-427 m	427-430 m	430-433 m	433-436 m	436-439 m	439-442 m	442-445 m	445-448 m	448-451 m	451-454 m	454-457 m	457-460 m	460-463 m	463-466 m	466-469 m	469-472 m	472-475 m	475-478 m	478-481 m	481-484 m	484-487 m	487-490 m	490-493 m	493-496 m	496-499 m	499-502 m	502-505 m	505-508 m	508-511 m	511-514 m	514-517 m	517-520 m	520-523 m	523-526 m	526-529 m	529-532 m	532-535 m	535-538 m	538-541 m	541-544 m	544-547 m	547-550 m	550-553 m	553-556 m	556-559 m	559-562 m	562-565 m	565-568 m	568-571 m	571-574 m	574-577 m	577-580 m	580-583 m	583-586 m	586-589 m	589-592 m	592-595 m	595-598 m	598-601 m	601-604 m	604-607 m	607-610 m	610-613 m	613-616 m	616-619 m	619-622 m	622-625 m	625-628 m	628-631 m	631-634 m	634-637 m	637-640 m	640-643 m	643-646 m	646-649 m	649-652 m	652-655 m	655-658 m	658-661 m	661-664 m	664-667 m	667-670 m	670-673 m	673-676 m	676-679 m	679-682 m	682-685 m	685-688 m	688-691 m	691-694 m	694-697 m	697-700 m	700-703 m	703-706 m	706-709 m	709-712 m	712-715 m	715-718 m	718-721 m	721-724 m	724-727 m	727-730 m	730-733 m	733-736 m	736-739 m	739-742 m	742-745 m	745-748 m	748-751 m	751-754 m	754-757 m	757-760 m	760-763 m	763-766 m	766-769 m	769-772 m	772-775 m	775-778 m	778-781 m	781-784 m	784-787 m	787-790 m	790-793 m	793-796 m	796-799 m	799-802 m	802-805 m	805-808 m	808-811 m	811-814 m	814-817 m	817-820 m	820-823 m	823-826 m	826-829 m	829-832 m	832-835 m	835-838 m	838-841 m	841-844 m	844-847 m	847-850 m	850-853 m	853-856 m	856-859 m	859-862 m	862-865 m	865-868 m	868-871 m	871-874 m	874-877 m	877-880 m	880-883 m	883-886 m	886-889 m	889-892 m	892-895 m	895-898 m	898-901 m	901-904 m	904-907 m	907-910 m	910-913 m	913-916 m	916-919 m	919-922 m	922-925 m	925-928 m	928-931 m	931-934 m	934-937 m	937-940 m	940-943 m	943-946 m	946-949 m	949-952 m	952-955 m	955-958 m	958-961 m	961-964 m	964-967 m	967-970 m	970-973 m	973-976 m	976-979 m	979-982 m	982-985 m	985-988 m	988-991 m	991-994 m	994-997 m	997-1000 m
157-160	160-163	163-166	166-169	169-172	172-175	175-178	178-181	181-184	184-187	187-190	190-193	193-196	196-199	199-202	202-205	205-208	208-211	211-214	214-217	217-220	220-223	223-226	226-229	229-232	232-235	235-238	238-241	241-244	244-247	247-250	250-253	253-256	256-259	259-262	262-265	265-268	268-271	271-274	274-277	277-280	280-283	283-286	286-289	289-292	292-295	295-298	298-301	301-304	304-307	307-310	310-313	313-316	316-319	319-322	322-325	325-328	328-331	331-334	334-337	337-340	340-343	343-346	346-349	349-352	352-355	355-358	358-361	361-364	364-367	367-370	370-373	373-376	376-379	379-382	382-385	385-388	388-391	391-394	394-397	397-400	400-403	403-406	406-409	409-412	412-415	415-418	418-421	421-424	424-427	427-430	430-433	433-436	436-439	439-442	442-445	445-448	448-451	451-454	454-457	457-460	460-463	463-466	466-469	469-472	472-475	475-478	478-481	481-484	484-487	487-490	490-493	493-496	496-499	499-502	502-505	505-508	508-511	511-514	514-517	517-520	520-523	523-526	526-529	529-532	532-535	535-538	538-541	541-544	544-547	547-550	550-553	553-556	556-559	559-562	562-565	565-568	568-571	571-574	574-577	577-580	580-583	583-586	586-589	589-592	592-595	595-598	598-601	601-604	604-607	607-610	610-613	613-616	616-619	619-622	622-625	625-628	628-631	631-634	634-637	637-640	640-643	643-646	646-649	649-652	652-655	655-658	658-661	661-664	664-667	667-670	670-673	673-676	676-679	679-682	682-685	685-688	688-691	691-694	694-697	697-700	700-703	703-706	706-709	709-712	712-715	715-718	718-721	721-724	724-727	727-730	730-733	733-736	736-739	739-742	742-745	745-748	748-751	751-754	754-757	757-760	760-763	763-766	766-769	769-772	772-775	775-778	778-781	781-784	784-787	787-790	790-793	793-796	796-799	799-802	802-805	805-808	808-811	811-814	814-817	817-820	820-823	823-826	826-829	829-832	832-835	835-838	838-841	841-844	844-847	847-850	850-853	853-856	856-859	859-862	862-865	865-868	868-871	871-874	874-877	877-880	880-883	883-886	886-889	889-892	892-895	895-898	898-901	901-904	904-907	907-910	910-913	913-916	916-919	919-922	922-925	925-928	928-931	931-934	934-937	937-940	940-943	943-946	946-949	949-952	952-955	955-958	958-961	961-964	964-967	967-970	970-973	973-976	976-979	979-982	982-985	985-988	988-991	991-994	994-997	997-1000	

a) These statistics represent values taken towards the end of each sample period. The reported values should therefore be the best representation for the abundance of the depth of interest.

b) The unit used (m/s) is the speed of motion and not the discharge rate.

c) Laboratory results.

d) Values are either actual measurements.

require very long measuring times of pressure fall-off to obtain reliable results.

The hydraulic conductivity decreases gently with depth; the only exception occurring at the intersection point of Zone 3 with the borehole. Zones 1 and 2 do not influence the conductivity as can be seen from Fig 5.58b).

5.4.1.1 Level 123-125 m (approx. 106 m)

The sampled borehole section is located within granodiorite which is dark-grey in colour, medium-grained and structurally foliated. The section itself is only weakly fractured comprising one fracture zone (10 cm wide and containing 3 fractures) and four single fractures. The intersection angle of the fractures with the drillcore axis ranges from 20-70° and the main fracture filling minerals are chlorite and calcite; iron oxides are present within the small fracture zone. Less than a metre above the sampled section is a strongly brecciated core length some 1.5 m in length which is stained with iron-oxides.

Hydrology

The hydraulic conductivity measured along the 25 m section containing the sampled length is $7.1 \cdot 10^{-9}$ m/s and the hydraulic head exceeds the hydrostatic head in the borehole by 2.1 metres. This excess, although smaller (+0.1 m), is confirmed by injection tests conducted along a 5 m section, the lower part of which contains the sampled length. Furthermore, most of the injected water appears to penetrate the crush zone located above the sampled level. The water budget calculations show that the borehole activities are not important as some 9 m³ of water are removed prior to sampling (Fig 5.59; Table 5.16a).

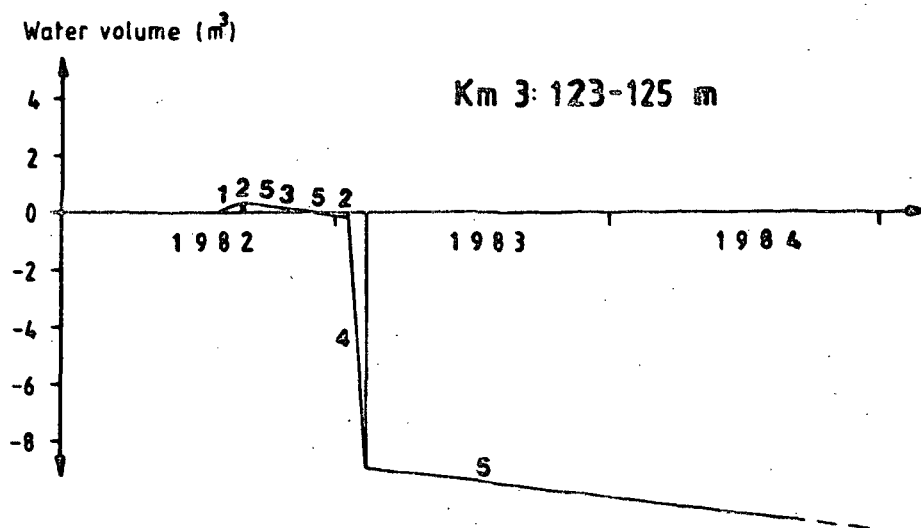

Figure 5.59: Schematic illustration of the calculated water budget for level 123-125 m in borehole Km 3 (Kamlunge). 1 = Drilling water; 2 = Gas-lift pumping; 3 = Hydraulic testing; 4 = Sampling; 5 = Open-hole effect.

Water geochemistry

The sampled water (Table 5.16b) is characterised by a pH of 7.9; the major cations Na^+ and Ca^{2+} , together with anions HCO_3^- and Cl^- , all show lower than normal values when compared to representative non-saline groundwaters in Swedish crystalline rocks (Table 5.1). This suggests a water of near-surface origin; negligible amounts of iodine (0.04 %) show an absence of drilling water.

Redox-sensitive parameters

Positive Eh values (+100 mV), a virtual absence of Fe(II) and S(-II), and a sizeable oxygen component (0.48 mg/l), all indicate a strongly oxidising groundwater environment.

Isotope geochemistry

No stable isotope data are available; the ^{14}C data record an age of 3375 years. The tritium value is extremely high (49TU) which supports the general water chemistry in that a young, surface to near-surface water origin is indicated.

Uranium geochemistry

High amounts of dissolved uranium are indicated (11.94-24.3 ppb) which once again suggests a strongly oxidising environment. The $^{234}\text{U}/^{238}\text{U}$ activity ratio of 2.8 indicates widespread groundwater disequilibrium.

Summary

Contrary to the water budget calculations which indicated that a representative groundwater sample was to be expected from this level, all chemical data show that the collected water was of surface or near-surface origin. Minimal tracer contents of iodine show that drilling water is not a major contaminating influence. The combination of high conductivity and a positive piezometric head, together with a sizeable crush zone within the near-vicinity of the sampled horizon, has probably resulted in near surface water being pumped from higher, more oxidised horizons in the bedrock, or from an interconnected fracture system to the borehole above the packer system which has collected water from higher more conductive levels.

No significant variation in the physico-chemical parameters of the water during the sampling period were observed.

5.4.1.2 Level 445-447 m (approx. 376 m)

This sampled horizon is characterised by amphibolite which is often biotite-rich and contains decimetre thick bands of grey granodiorite. The area around the section is heavily tectonised and represents the intersection of local fracture Zone 3. The actual borehole length sampled is less fractured than the adjacent bedrock. It consists of one broad fracture zone (comprising 16 fractures) and 6 single fractures; the intersection angles with the core axis range from 30-70° and the dominant fracture filling minerals are pyrite, chlorite and biotite.

Hydrology

The sampled horizon is located within the most conductive part of the Zone 3. The calculated k -value of the Zone is $3 \cdot 10^{-8}$ m/s and the corresponding value for the 25 m section is $1 \cdot 10^{-8}$ m/s with an excess head of +6.3 m. The 5 m length records $k = 1.2 \cdot 10^{-7}$ m/s with a piezometric head of +0.9 m. Regardless of which values are used for the water budget calculations, the general combination of high conductivity and piezometric head should ensure that the water sample is representative (Fig 5.60).

Water geochemistry

The sampled water (Table 5.16b) has a pH of 8.4; of the major cations, Na^+ and Ca^{2+} are present in low amounts, likewise for the major anions HCO_3^- and Cl^- . These waters, in common with those just described for the previous horizon, are therefore characteristically surface to near-surface in origin and not typical of the non-saline groundwaters that one would have expected. Negligible iodine (tracer) shows an absence of drilling water contamination.

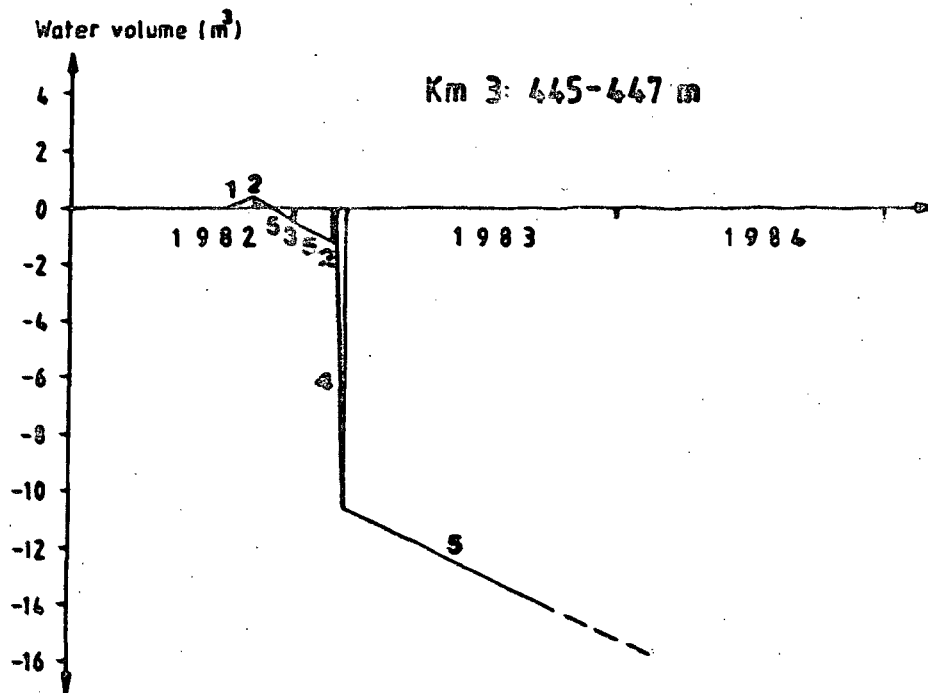

Figure 5.60: Schematic illustration of the calculated water budget for level 445-447 m in borehole Km 3 (Kaniange). 1 = Drilling water; 2 = Gas-lift pumping; 3 = Hydraulic testing; 4 = Sampling; 5 = Open-hole effect.

Redox-sensitive parameters

Markedly negative Eh values (-150 mV), even though there is a low Fe(II) and an absence of S(-II), indicate that the groundwaters are considerably more reducing than the previous level; this is further supported by an absence of oxygen.

Isotope geochemistry

No stable isotope data are available. The very high tritium values (56 TU), together with a young ^{14}C (2985 years), lend further support of a surface to near surface origin to the sampled groundwaters.

Uranium geochemistry

The groundwaters are still characterised by a high uranium content (5.51-16.2ppb); a $^{234}\text{U}/^{238}\text{U}$ activity ratio of 3.2 indicates widespread disequilibrium.

Summary

The hydraulic combination of high conductivity and piezometric head should have ensured a representative ground water sample devoid of contaminants such as drilling water, surface to near-surface water and borehole water. However, the results show that the water has a surface to near-surface character, is uncontaminated by residual drilling water, and is markedly reducing. In general, the water is not representative of this depth (vertical depth of 376 m) in the bedrock apart from its reducing character, but is very probably typical of downward moving groundwaters in the fracture Zone 3 which is thought to extend to the bedrock surface. The high tritium contents show that the water is still young but appreciably older than present precipitation in the Kamlunge area (approx. 35TU). The results all serve to illustrate the very strong hydraulic gradient within these large-scale fracture zones. Because of the very fractured nature of the bedrock, some of the sampled water may have originated from the borehole.

No systematic variation of the measured physico-chemical parameters of the groundwater were observed during the sampling period.

5.4.1.3 Borehole summary and discussion

Geological and hydrological investigations within borehole Ka 3 have confirmed the existence of three major fracture zones (Zones 2, 3 and 4) considered through

geophysical measurements to extend to the bedrock surface. The natural groundwater flow in the near-vicinity of the borehole is directed downwards towards the regional lineament which demarcates the western edge of the plateau. In general, the hydraulic conductivity decreases with depth with the exception of Zone 3 which shows an increase to 1.10^{-8} m/s from an average background borehole value of 1.10^{-11} m/s as measured along 25 m borehole sections.

Of the two levels sampled, the upper level at 123-125 m is sufficiently shallow to be influenced by the tension-release fractures which commonly characterise the upper 200-250 m of the Swedish bedrock. The hydraulic conductivity is therefore fairly high within this upper bedrock region, and in this case is accompanied by a positive piezometric head, at least from approx. 100-300 m depth. The lower sampled level, being located at the borehole intersection with Zone 3 (445-447 m), is also characterised by high conductivity and piezometric head values. Thus, the water budget calculations from these two levels suggest that all contaminating waters introduced prior to sampling (i.e. drilling water and water introduced during hydraulic testing) are minimal and are effectively removed by pumping prior to sampling. The sampled groundwaters should therefore be representative.

The overall chemistry of the groundwaters indicates that neither level has resulted in a representative sample. The chemistries are remarkably similar except that the deeper level waters are more reducing. In general, both sampled levels are characterised by surface to near-surface waters with high tritium contents (49-56 TU), low ^{14}C ages (2985-3575 years) and very high amounts of dissolved uranium (5.5-24.3 ppb). The virtual absence of the iodine tracer (0.04 B) shows that no drilling water component is present. It is therefore apparent that the collected groundwaters have a similar near-surface source with rapid transport to depth being facilitated

by highly conductive fracture zones such as Zones 2 and 3 which intersect the borehole at the deeper sampled level. In addition, the very marked open-hole effects will result in large amounts of near-surface derived water being present in the borehole; open fracture systems around the borehole can easily lead to such borehole water being leaked around the packer system during sampling.

The uranium content of the sampled groundwaters from borehole Km 3 is extremely high although there is a distinct decrease between the upper and lower sampled levels (i.e. 11.94 ppb vs 5.51 ppb). The analytical contents, together with the theoretical Eh values calculated for the iron system, are presented in Table 5.17 and Figure 5.61. The Figure also contains theoretical uranium solubility curves calculated from crystalline and amorphous UO_2 for a pH of 8.10 which is reasonably representative for the waters from the borehole. Both water compositions plot around the amorphous uranium stability boundary; the upper level just inside the crystalline stability boundary.

Table 5.17: Uranium content and theoretical Eh values of the groundwater from borehole Km 3.

Level (metres)	Uranium Content (ppb)	Calculated Eh (mV)
123-125	11.94	-74
445-447	5.51	-212

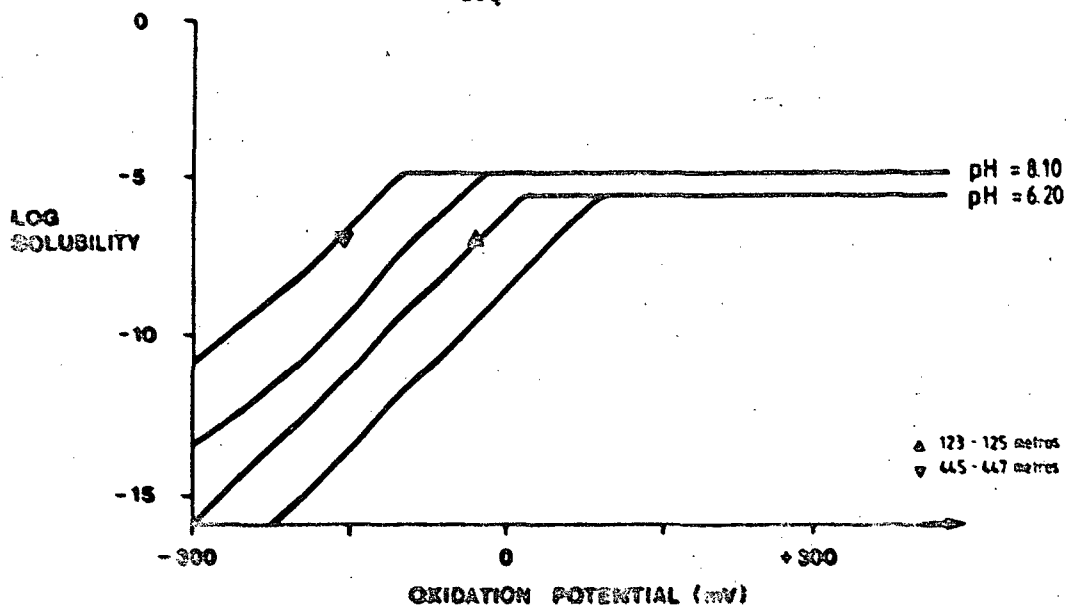

Figure 5.61: Plots of uranium content (expressed as log (mol/litre)) and the calculated theoretical Eh values of groundwaters collected from borehole Km 3. The values are plotted with respect to theoretical uranium solubility curves calculated for amorphous (lower stability limit) and crystalline (upper stability limit) UO_2 at a pH of 9.50.

5.4.2 Borehole Km 13

Borehole Km 13, drilled at an angle of 60° in an ESE direction towards Zone 5 (Fig 5.56), is located within the southern central part of the Kamlunga test-site area. The total length of the hole is 703.05 m (vertical depth of approx. 600 m) and the primary objective was to obtain more geological information about the SE quadrant of the test-area. As a result, a weak sub-horizontal fracture zone was encountered at a depth of about 670 m.

The dominant rock-type in the borehole is granite (56.9 % of the borehole length) followed by 18 % biotite gneiss, 11.9 % quartzitic gneiss, 8.5 % amphibolite and 4.3 % granodiorite. The uppermost part of the hole (down to around 350 m) is dominated by granite with pegmatite

horizons and minor bands of quartzitic gneiss. Between 365-413 m amphibolite is present; a small thickness also occurs around 700 m, otherwise the rest of the hole consists of an intermixture of granodiorite, granite/pegmatite and biotite gneiss. The average fracture frequency of the borehole is 3.40 fractures/metre. For the component rock-types, the lowest fracture frequency is recorded by granodiorite (2.14 fractures/ metre) followed by biotite gneiss (3.15), granite (3.25), amphibolite (4.22) and lastly quartzitic gneiss (4.62). The majority of the fractures are parallel to the regional foliation and these also vary between the different rock-types; for example up to 53 % for the biotite gneiss and a minimum of 16 % for the quartzitic gneiss. In general, the frequency of fractures is low throughout the borehole length; an obvious exception occurs at the intersection of the sub-horizontal zone around 670 m. The main fracture infilling minerals are chlorite, calcite and zeolite; within and around the sub-horizontal fracture zone, which is located within a pegmatite horizon, the rock is weathered and stained with iron-oxides which include hematite.

The presence of the sub-horizontal fracture zone greatly influences the groundwater conditions as it dissipates the piezometric head gradient in the bedrock such that the head gradient becomes much less below the zone than above it (Fig 5.62). This implies lower groundwater flow-rates below the zone and consequently the possibility of encountering older waters. The large-scale groundwater flow-pattern in the vicinity of the borehole shows that water recharging at the highest part of the plateau to the NW of Km 13, passes the borehole on its way to local fracture Zone 5 (Fig 5.56). The piezometric head along the borehole decreases almost linearly from 145 to 133 metres above sea-level at the hole bottom (Fig 5.63c). The piezometric head distribution obtained from the field investigations have generally accommodated this variation with some notable exceptions. For example, at borehole lengths around 230, 360 and 675 m the

Km 13

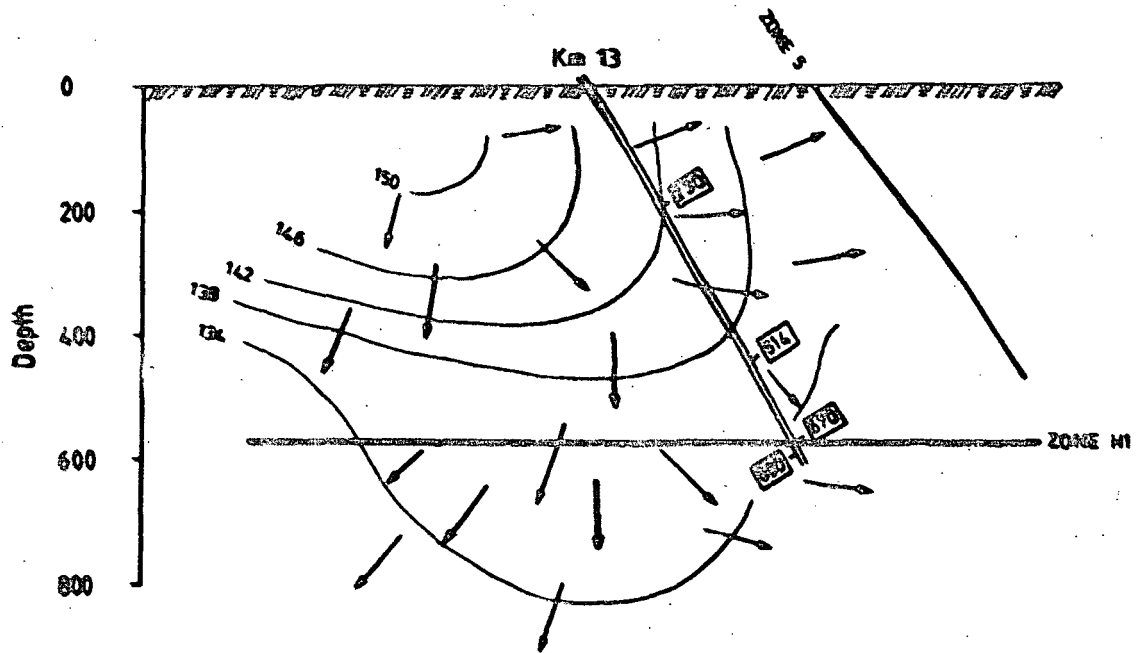

Figure 5.62: The groundwater flow-pattern and isopotentials in the vicinity of borehole Km 13 illustrated by a vertical section in the same plane as the direction of the borehole (modified after the numerical modelling of the Kenakta Consulting Co).

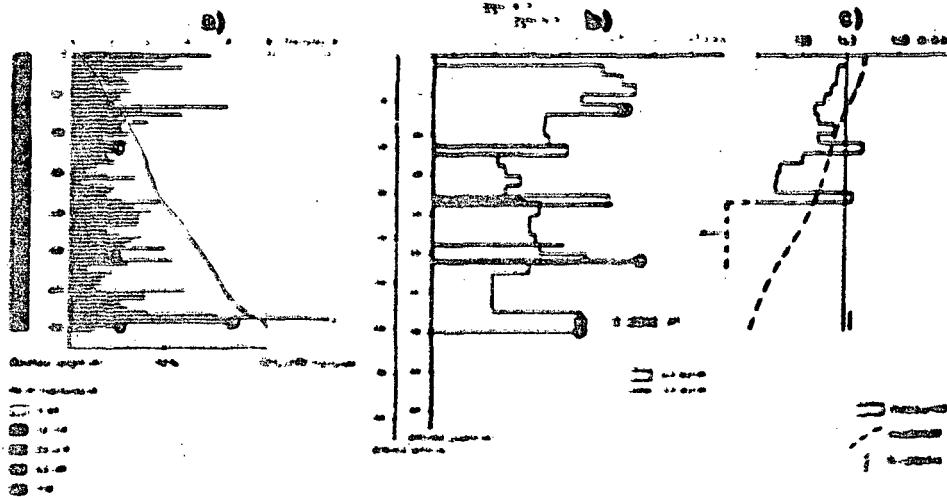

Figure 5.63: Hydrogeological characteristics of borehole Km 13.
 a) Fracture frequency (for 10 m sections) and the cumulative percentage of fractures.
 b) Hydraulic conductivity
 c) Piezometric head distributions and hydrostatic head in the borehole.

piezometric head is essentially higher. The normal hydraulic conductivity pattern is reflected by measurements which show only a few sections with a K-value less than 1.10^{-9} m/s occurring below 200 m. Above 200 m the conductivity is unusually low.

Table 8.16a: Measured hydraulic parameters and calculated water budget values of the various influences due to borehole activities at the water sampled levels in borehole No 13.

Level (in hole length)	K-value ^a (m/s)	Head deviation ^b (m)	Flow direction (borehole trends)	Drilling water(+) (m ³)	Gas-lift pumping(-) (m ³)	Hydraulic testing(+) (m ³)	Open hole effect before sampling(?) (m ³)	Sampled water before analysis (-) (m ³)
230-232	$9.5 \cdot 10^{-10}$	+1.8	(-)	0.234	0.038	+0.001	-0.063	1.4
314-316	$3.1 \cdot 10^{-9}$	-11.2	-	0.004	0.170	+0.001	+0.917	+5.0
670-672	$2.5 \cdot 10^{-9}$	+0.7	-	+0.1	0.094	+0.001	-0.029	3.4
680-682	$1.5 \cdot 10^{-9}$	+0.7	-	+0.1	0.094	+0.001	-0.038	+2.0

^a 25 m section; head deviation from hydrostatic head in the borehole (in metre of water)
^b 11 m section

Table 8.16b: The hydraulic parameters of groundwater sampled from the 130 borehole area (continued).

Level	K-value	Head deviation	Flow direction	Drilling water	Gas-lift pumping	Hydraulic testing	Open hole effect	Sampled water
130-132								
134-136								
138-140								
142-144								
146-148								
150-152								
154-156								
158-160								
162-164								
166-168								
170-172								
174-176								
178-180								
182-184								
186-188								
190-192								
194-196								
198-200								
202-204								
206-208								
210-212								
214-216								
218-220								
222-224								
226-228								
230-232								

^a These values represent values from levels at the top of the sampled zone. The reported values are the average for the last 10 metres of the borehole at the level of investigation.
^b The value of the head deviation is the average value.
^c The value of the head deviation is the average value.
^d The value of the head deviation is the average value.
^e The value of the head deviation is the average value.

5.4.2.1 Level 230 - 232 m (approx. 197 m)

The investigated level lies within quartzitic gneiss characterised by biotite-rich bands together with schlieren and dykes of pegmatite. The sampled borehole length contains very little evidence of fracturing; only 7 single fractures intersect the core axis at angles ranging from 30-60° with the main filling minerals being pyrite, chlorite and zoelite.

Hydrology

The hydraulic conductivity measured along the 25 m section is $9.6 \cdot 10^{-10}$ m/s and the head deviation is +1.8 m. Injection tests along 5 m sections outside the sampled level support the hydraulic parameters used in the water budget calculations (Table 5.18a) which are therefore considered to be representative for the actual section, i.e. the low K-value results in only small volumes of contaminated water being introduced into the bedrock from the borehole activities. As shown by Figure 5.64 any contaminating effects should be adequately removed prior to sampling.

Water geochemistry

The water sampled (Table 5.18b) recorded a pH of 8.4; of the major ions, Na^+ and HCO_3^- are present in lower amounts, and Ca^{2+} in higher amounts, than normal non-saline bedrock groundwaters usually characteristic of this depth; the Cl^- content is about normal (5 mg/l). The high Ca^{2+} (99 mg/l) can be correlated to higher than normal SO_4^{2-} contents in the groundwaters. The presence of 0.21 % of iodine tracer indicates the presence of a small drilling water component.

Redox-sensitive parameters

Negative Eh values (-70 mV) and virtually no oxygen (0.07 mg/l) indicate a moderately reducing groundwater environment; the contents of Fe(II) and S(-II) are low.

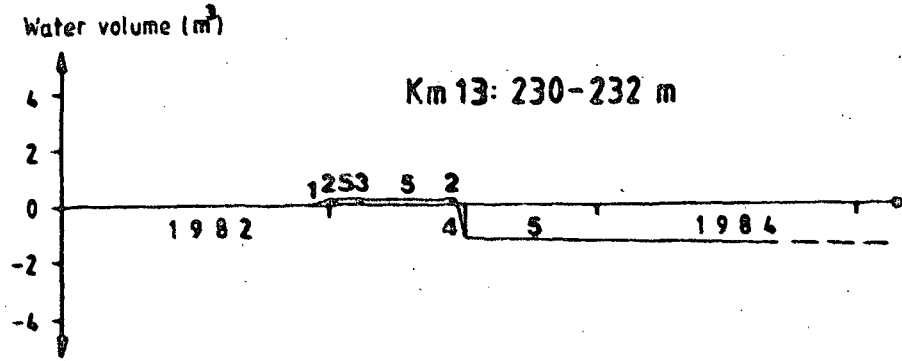

Figure 5.64: Schematic illustration of the calculated water budget for level 230-232 m in borehole Km 13 (Kamlunge). 1 = Drilling water; 2 = Gas-lift pumping; 3 = Hydraulic testing; 4 = Sampling; 5 = Open-hole effect.

Isotope geochemistry

No stable isotopic data are available; ¹⁴C, however reveals an age of 7365 years. The tritium value of 10 TU indicates a sizeable near-surface component.

Uranium geochemistry

The dissolved uranium content is high (5.2 ppb); the ²³⁴U/²³⁸U activity ratio is 2.1 which shows isotopic disequilibrium in the groundwater environment.

Summary

Low hydraulic conductivity values and a small positive piezometric head suggested minimum contamination into the bedrock during the various borehole activities. A representative groundwater sample was therefore expected.

The chemical parameters have established that a reducing groundwater environment exists at the sampled level. The

major ion concentrations (e.g. low levels of Na^+ , HCO_3^- and Cl^-) show that a sizeable surface to near-surface component is present, a fact supported by moderate tritium contents (10 TU) and 0.21 % I^- (tracer). However, the relatively old age of the water (^{14}C age of 7365 years) suggests that some portion of the water is probably representative for the sampled depth.

A further aspect of the groundwater chemistry is the high SO_4^{2-} content (approx. 200 mg/l). As CaSO_4 , this probably explains the increased conductivity value (56 mS/m) of the water.

In summary, the results from this level indicate a water characterised by:

- representative water from the sampled depth. This is reducing in nature, relatively old, and has a distinct chemistry as shown by the unusually high CaSO_4 content.
- the presence of residual drilling waters which are near-surface in origin.
- the presence of surface to near-surface waters from the borehole which have originated from higher levels in the bedrock.

Mixing of these different water types has probably been facilitated by the low K-values of the section which has led to leakage of borehole water past the packer system. However, systematic changes in the physico-chemical parameters of the groundwaters during sampling (Laurent, 1983d) show a steady increase in Na^+ , Ca^{2+} , Cl^- and SO_4^{2-} and a decrease in Eh. This infers that increasingly more representative groundwater is being encountered as a result of the gradual removal of residual contaminating waters resulting from the borehole activities.

5.4.2.2 Level 514 - 516 m (approx. 432 m)

In contrast to the previous level, the dominant bedrock at this depth consists of biotite gneiss with schlieren and dykes of pegmatite. The sampled borehole length is similarly lacking in major shear or crush zones, containing just 7 single fractures. These intersect the core axis at angles ranging from 45-80°, and the main infilling minerals are pyrite, calcite and zeolite with more minor amounts of chlorite.

Hydrology

The level sampled has been selected from a highly conductive 25 m section ($K = 3.1 \cdot 10^{-9}$ m/s); this is supported by data from two 5 m sections. Each of these 5 m sections has a transmissivity exceeding that of the 25 m section (i.e. a greater amount of water is injected within each 5 m section than in the total 25 m section). This is best explained by leakage occurring around the packers. It was noted that two fracture zones (45 m wide) coincided with the level of one of the packers. As these fracture zones are not included in the sampled section, it can be concluded that the level sampled is characterised by a smaller k-value thus making the calculated water budget a realistic one (Fig 5.65). The water removed by pumping prior to sampling is greater than 5 m³ which should have secured a representative sample.

Water geochemistry

The groundwater sample is characterised by a pH of 8.6; the major ion characteristics are similar to those of the previous level although more accentuated. For example, greater amounts of especially Ca²⁺ (and SO₄²⁻) with more minor increases of Na⁺, Cl⁻ and HCO₃⁻.

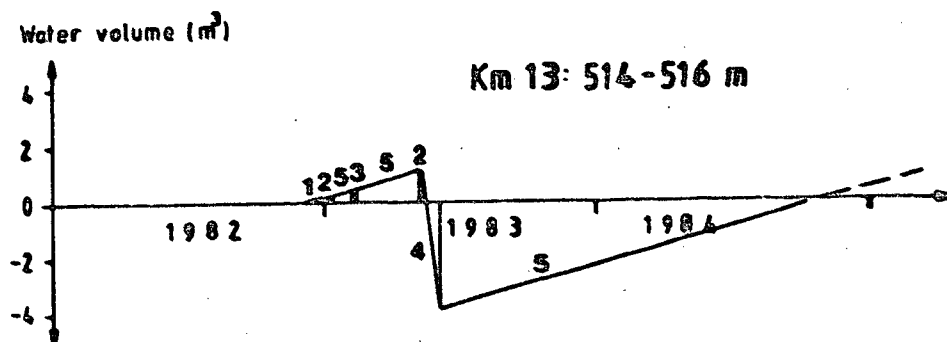

Figure 5.65: Schematic illustration of the calculated water budget for level 514-516 m in borehole Km 13 (Kamlunge). 1 = Drilling water; 2 = Gas-lift pumping; 3 = Hydraulic testing; 4 = Sampling; 5 = Open-hole effect.

- A small I^- content (0.16 %) suggests some mixing of near-surface derived drilling waters.

Redox-sensitive parameters

The groundwaters sampled are still reducing ($E_h = -100$ mV) although slightly more than the previous level. Fe(II) and S(-II) are still low and significant amounts of oxygen are present (0.1 mg/l).

Isotope geochemistry

Stable isotope data are not available; ^{14}C data records an age of 6460 years. The tritium value of 18 TU suggests a substantial near-surface component, somewhat greater than the previous level.

Uranium geochemistry

Greater amounts of dissolved uranium (10.2 ppb) supports a substantial component of near-surface, less reducing

groundwater. The $^{234}\text{U}/^{238}\text{U}$ activity ratio of 1.8 indicates disequilibrium in the sampled waters.

Summary

The selected borehole length is characterised by single fractures and a moderate hydraulic conductivity. The water budget calculations infer that a representative sample should be obtained subsequent to gas-lift pumping and pumping just prior to sampling. However, the chemical parameters measured show a marked component of near-surface water derived from higher levels and transported to the sampling depth probably by the borehole itself. This borehole water was subsequently leaked past the packer system during sampling.

The major portion of the sampled water is reducing and characterised by a high CaSO_4 content. Because of groundwater mixing from other sources the recorded ^{14}C age reflects dilution by younger waters (i.e. near-surface waters resulting in a tritium of 20 TU) and so a much older age would be more realistic.

In summary, the results from this level indicate a groundwater characterised by:

- residual water from borehole activities, e.g. drilling water, aided by a negative piezometric head.
- mixed water sources from within the borehole; this includes a considerably younger near-surface component probably introduced around the packer system.
- major portion of representative groundwater of distinct chemistry

Variations in the groundwater chemistry (Laurent, 1983d) during sampling show clearly that the groundwaters are becoming much more reducing, richer in CaSO_4 and slightly more saline; a small increase in pH also occurs.

5.4.2.3 Level 670 - 672 m (approx. 556 m)

The sampled section is located within an approximately 15 m thick layer of granite with numerous pegmatite horizons. The section is markedly fractured and represents part of the weak sub-horizontal Zone H1 which intersects the borehole around 667-673 m. The sampled section overlaps with one dominant fracture zone which extends from 671.40-674.25 m and comprises 78 fractures, many of which are present within the sampled section. In addition, one smaller fracture zone of 40 cm width and comprising 15 fractures, is located within the section, together with 4 single fractures. The range of angle intersections with the core axis is 0-90° and the main filling minerals are iron-oxides (hematite + hydroxy iron-oxides), calcite, pyrite and more rarely chlorite.

Hydrology

Not surprisingly the groundwater transport at this depth is strongly influenced by the sub-horizontal fracture Zone H1. The hydraulic conductivity of Zone H1 is set to 1.10^{-8} m/s and is estimated from the single packer test (assuming that it stands for 50 % of the transmissivity), which is the only hydraulic test conducted at this level. The 53 m long measured section indicates an excess piezometric head. However, even though the overall lack of detailed hydrologic data make the water budget calculation somewhat uncertain, the great volume of groundwater sampled (3.4 m^3) may provide a sample that is fairly representative (Fig 5.65).

Water chemistry

The major chemical parameters (Table 5.18b) are all characterised by lower than normal values for non-saline groundwaters that may be expected from such sampled

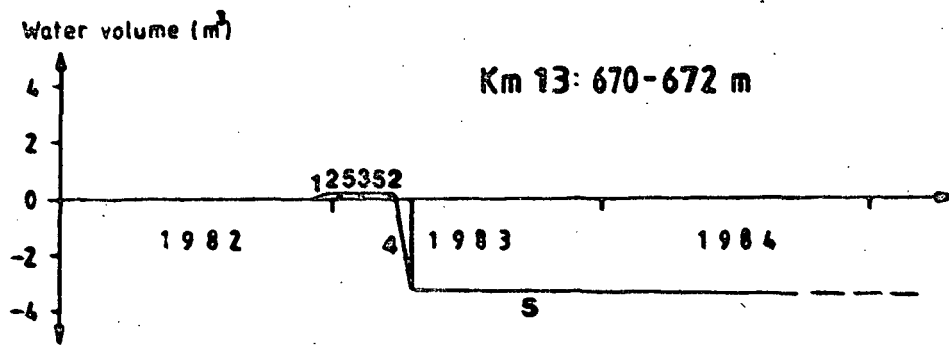

Figure 5.66: Schematic illustration of the calculated water budget for level 670-672 m in borehole Km 13 (Kamlunge). 1 = Drilling water; 2 = Gas-lift pumping; 3 = Hydraulic testing; 4 = Sampling; 5 = Open-hole effect.

depths. These values, such as a pH of 6.9, and major ion contents of 5 mg/l for Na^+ , 8 mg/l for HCO_3^- and 5 mg/l for Cl^- , are more in accordance with surface to near-surface waters.

Redox-sensitive parameters

En values show that the groundwater environment is marginally oxidising (+50 mV); this is supported by small oxygen contents (0.09 mg/l). The Fe(II) content is unusually high (6.8 mg/l); S(-II) is negligible.

Isotope geochemistry

No stable isotope data are available; ^{14}C records a very young age of 1015 years and almost certainly indicates water of a surface or near-surface origin. This is supported by a tritium value of 39 TU which is near the average for surface precipitation.

Uranium geochemistry

Dissolved uranium values are low (0.09-0.6 ppb); these together with an $^{234}\text{U}/^{238}\text{U}$ activity ratio of 1.8, indicate a typical surface water origin.

Summary

Although the hydrological data are inadequate, the very fractured nature of the sampled section length, the apparently high hydraulic conductivity and an estimated positive piezometric head, all combine to suggest that a representative water sample is possible. The results show, however, that the sampled water is surface to near-surface in origin with no evidence of any deep groundwater component. The only obvious source is borehole water which has been derived from the near-surface environs of the bedrock. Accumulation in the sampled section has been by leakage past the packer system during sampling.

5.4.2.4 Level 690 - 682 m (approx. 564 m)

This sampled level is located some 6 m below the sub-horizontal Zone H1 described above; the dominant rock-type is a fine-grained amphibolite. The section includes a narrow crush zone (15 cm wide), one fracture zone (70 cm wide and containing 15 fractures), and 8 single fractures. The major infilling minerals are iron-oxide (hematite + hydrous types), calcite, chlorite and zeolite.

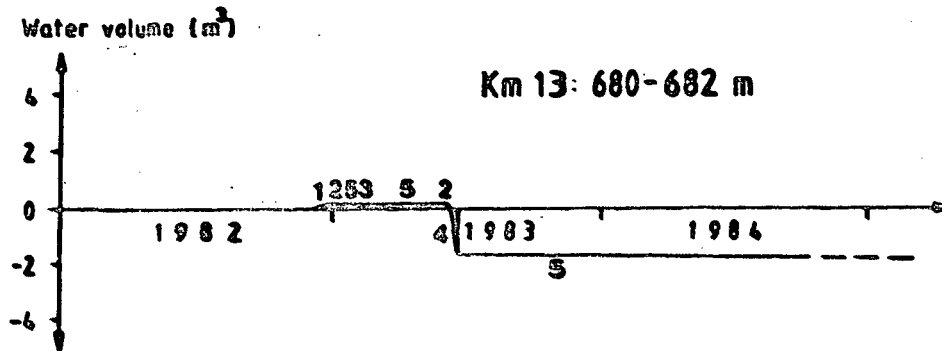

Figure 5.67: Schematic illustration of the calculated water budget for level 680-682 m in borehole Km 13 (Kamlunge). 1 = Drilling water; 2 = Gas-lift pumping; 3 = Hydraulic testing; 4 = Sampling; 5 = Open-hole effect.

Hydrology

The available hydrological data are similar to that of the previous level and therefore the calculated water budget (Fig 5.67) exhibits the same inadequacies. From a general hydrological point of view, as expressed at the beginning of this chapter, an older, perhaps a chemically distinct groundwater, might be expected from this level as it is situated below the sub-horizontal fracture Zone.

Water geochemistry

All the measured parameters show a water identical in composition to previous level (Table 5.10b).

Redox-sensitive parameters

In common with the previous level, all indications are that near-surface derived groundwaters of a marginally oxidising character have been collected.

Isotope geochemistry

No stable isotope data are available; ^{14}C records an age of 800 years which is totally unrealistic for these depths but supports a near-surface origin to the groundwater.

Uranium geochemistry

Similar to the previous level.

Summary

Hydrologically this level differs little from the previous. Geologically the section is less fractured and another rock-type dominates. In general, it is assumed that any contamination resulting from borehole activities should be effectively removed prior to sampling. However, once again the results show that surface to near-surface derived water has been preferentially pumped around the packer system to the section being sampled, rather than from the bedrock itself. This has probably been facilitated by an interconnected fracture network between the section and the borehole water. There is no indication of any deep groundwater component and one must therefore assume that the section chosen for sampling is non-conducting.

5.4.2.5 Borehole summary and discussion

Geological mapping and hydrological investigations along 25 m sections in the borehole (5 m sections have sometimes been measured in and around those levels sampled) have resulted in the sampling of groundwater from four different levels, the two deepest being located within and below the intersection of the borehole with a sub-horizontal fracture zone at 667-673 m borehole

length. This zone is hydrologically important in that it serves to dissipate the piezometric head gradient in the bedrock so that the head gradient becomes much less below the zone than above it. There was therefore the possibility that groundwaters of differing composition would characterize these two environments. In all cases the calculated water budgets were positive in that any contamination due to borehole activities would be effectively removed by pumping prior to sampling. The sampled groundwaters should therefore be fairly representative.

The natural groundwater flow around the borehole is generally downwards and towards the north-west. Within the borehole itself, hydraulic conductivity and head measurements indicate that the water is downwards within most of the borehole length (down to about 550 m) and upwards within the deepest parts of the hole. The uppermost level at 230-232 m is characterized by a low K-value and a small positive piezometric head. Contamination from borehole activities should be minimal and easily removed prior to sampling. Even so, there is some possibility that this level may be the source for some near-surface derived groundwaters into the borehole. The 514-516 m level is characterized by a low to moderate hydraulic conductivity and a negative piezometric head. Contamination is again possible but such effects were expected to be removed prior to sampling. The two deepest levels (670-672 m and 680-682 m) referred to above, are both characterized by moderate hydraulic conductivity and a piezometric head that is more or less neutral. Pumping prior to sampling was considered to be adequate to remove any contaminating waters originating from other sources. From the measured chemical parameters of the groundwaters the two upper levels contain varying portions of water which is chemically distinct (i.e. unusually high content of CaSO₄) for the Kamburo area and is probably representative for those general depths. In both cases the variation in chemistry during the sampling periods

indicated that the waters were becoming more reducing, less contaminated and therefore more representative. The representative nature of these waters is further supported by their relatively old ages as indicated by the ^{14}C data (6460-7365 years). Unfortunately, mixing with surface to near-surface waters has taken place (i.e. 10-18 TU and 0.07-0.10 mg/l oxygen), with the result that a significant amount of "dilution" has occurred.

These near-surface waters at such depths are probably a result of some residual drilling water being present in the bedrock section (e.g. 0.16-0.21 % I^- have been recorded), and also borehole waters being leaked around the packer system during sampling. The former explanation is more acceptable as the groundwaters become more representative during sampling which infers a systematic depletion of these contaminating waters.

The two deepest zones are anomalous in that the sampled water is almost completely surface to near-surface in origin with very little influence of deeper groundwaters such as those just described. It would appear that during sampling the water capacity of the bedrock section proved to be inadequate. A partial vacuum was soon established within the sampling section resulting in near-surface derived water being leaked around the packer system. This is supported by the high Fe(II) contents from these two levels (6.8-8.2 mg/l) which previously have been interpreted as a reaction of borehole water with the steel piping that extends to the surface from the packer system.

In summary, the major groundwater types represented by borehole Km 13 are: 1) surface and near-surface waters of a young age, 2) intermediate to deep old groundwaters which are non-saline but are characterised by a high CaSO_4 content. Unfortunately, none of the groundwaters sampled can be considered truly representative.

The uranium content of the borehole groundwaters shows a marked change from the high values characterising the upper two levels (5.2 - 10.2 ppb) and the two lower levels located above and below the sub-horizontal zone H1 (0.04 - 0.60 ppb). Although these results show an apparent decrease with depth, the uncertainty surrounding the representative nature of the groundwaters makes interpretation difficult. In any case the analytical contents, together with the theoretical Eh values calculated for the iron system, are presented in Table 5.19 and Figure 5.68. The Figure also contains theoretical uranium solubility curves calculated from crystalline and amorphous UO_2 for a pH of 6.20, 8.10 and 9.50 which are reasonably representative for the waters from the borehole. The water compositions plot within and around the uranium stability curves for the highest and lowest chosen pH values, a spread reflecting the general inconsistency of the groundwater compositions.

Table 5.19 Uranium content and theoretical Eh values of the groundwaters from borehole Km 13.

Level (metres)	Uranium Content (ppb)	Calculated Eh (mV)
230 - 232	5.2	-199
514 - 516	10.2	-249
670 - 672	0.09	- 19
680 - 682	0.04	- 20

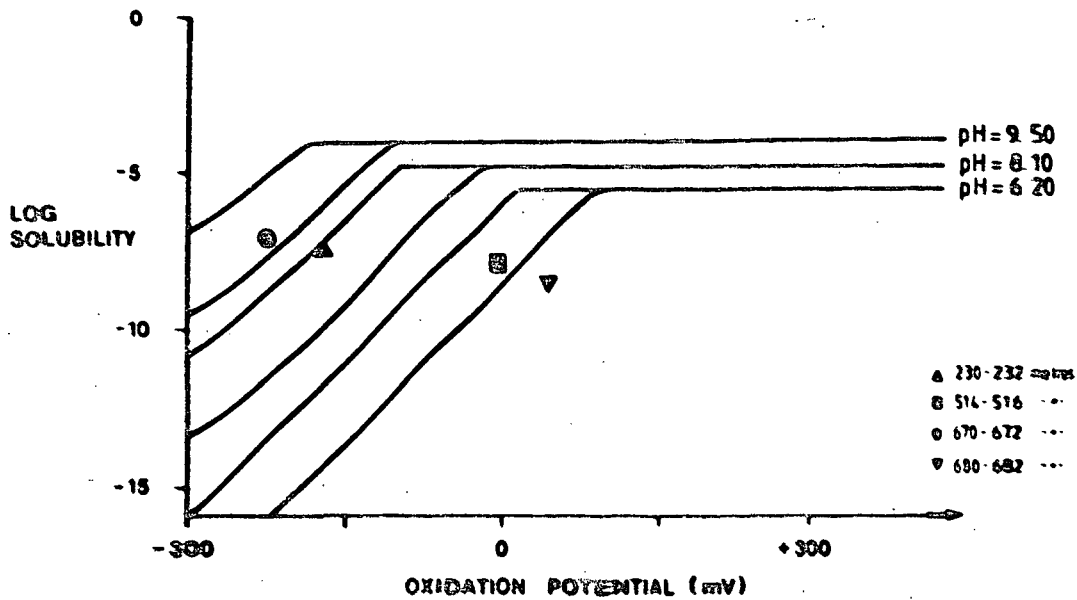

Figure 5.68: Plots of uranium content (expressed as log (mol/litre)) and the calculated theoretical Eh values of groundwaters collected from borehole Km 13. The values are plotted with respect to theoretical uranium solubility curves calculated for amorphous (lower stability limit) and crystalline (upper stability limit) UO_2 at a pH of 6.20, 8.10 and 9.50.

5.4.3 Borehole Km 8

Borehole Km 8 is located in the west central part of the Kaniunga test-area, some 50 metres from the surface expression of local fracture Zone 3 (Fig 5.56). The borehole (length 251.25 m; vertical depth approx. 200 m) was drilled at an angle of 60° to confirm the presence at depth of Zone 3; this was achieved at approx. 100 m.

Strongly foliated biotite gneiss, with more minor interlayers of skarn, pegmatite and quartz bands, dominate the upper 100 m or so of the borehole. A more substantial pegmatite horizon which is heavily tectonised and stained with iron-oxides occurs from 35-45 m. With increasing depth granodiorite, with pegmatite horizons, begins to dominate; around 236 m biotite gneiss appears. The average fracture density for the borehole is high (7.30 fractures/metre) which is partly attributed to the short length of the borehole and partly due to the fact that Zone 3 is intercepted. Of the different rock components, granite records the highest frequency of fractures (10.28 fractures/metre), followed by biotite gneiss (9.52), amphibolite (7.86) and lastly granodiorite (3.69). The most common fracture filling minerals are hematite, chlorite and calcite; local fracture Zone 3 is characterised by several crush and fracture zones which are generally brecciated and strongly weathered. Hematite and other more hydrous iron-oxides impregnate the fracture zones and the adjacent bedrock.

The groundwater pattern modelled by Carlsson et al (1983) is illustrated in Figure 5.69. The groundwater flow around the borehole is locally directed upwards along fracture Zone 3, and more generally near Zone 2; otherwise the dominating flow near Km 8 is downwards. According to the model the piezometric head changes very little along the length of the borehole, but much more dramatically at depths of 350-550 m. Due to the very large fracture density within this part of the bedrock, it was impossible to conduct water injection tests in the hole as planned without risking the equipment. As a result only single packer injections were performed in the upper part of the borehole.

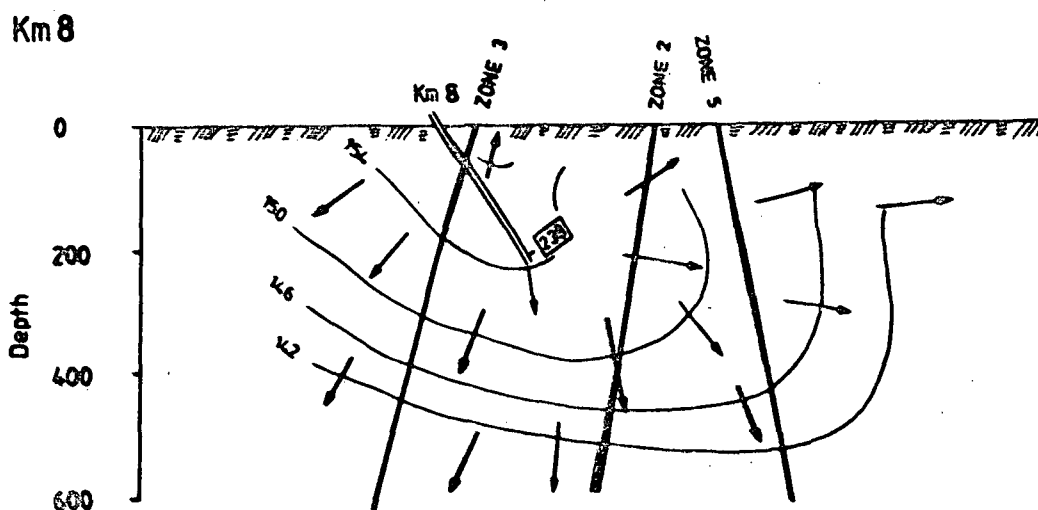

Figure 5.69: The groundwater flow-pattern and isopotentials in the vicinity of borehole Km 8 illustrated by a vertical section in the same plane as the direction of the borehole (modified after the numerical modelling of Kemakta Consulting Co).

5.4.3.1 Level 238 - 240 m (approx. 198 m)

The sampled borehole is located within diorite gneiss which locally changes to epidote-rich skarn or diffuse bands of granodioritic composition when the granodiorite contact at 236 m is approached. The sample section length is characterised by 3 fracture zones ranging in width from 30-40 cm and each containing 5-6 fractures; the bottom of the section partly overlaps another, much broader fracture zone, consisting of 11 fractures. In addition to these zones, the section contains 6 single fractures. The intersection angle of these structures with the core axis varies from 10-90° and the main filling minerals are chlorite, calcite, iron-oxides and minor amounts of epidote.

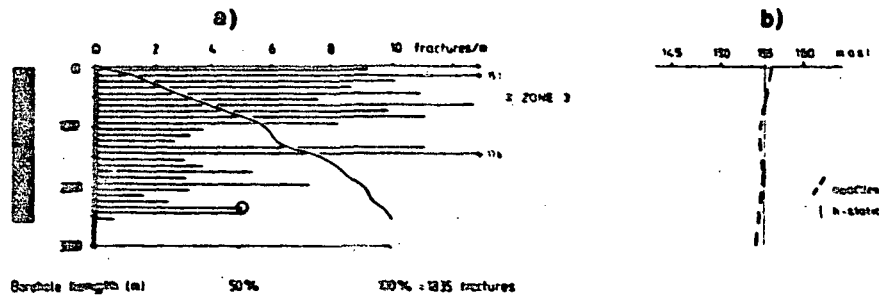

Figure 5.70: Hydrological characteristics of borehole Km 8:

- a) Fracture frequency (for 10 m sections) and the cumulative percentage of fractures
- b) Piezometric head distribution and hydrostatic head in the borehole.

Hydrology

The hydraulic conductivity measurements from the single injections tests give an average value of $1.4 \cdot 10^{-7}$ m/s for the borehole section 71 to 251 m. However, the overall lack of detailed hydrologic data from the borehole as a whole, and from the sampled section in particular, made it pointless to carry out water budget calculations. Nevertheless, some estimation of the borehole conditions can be made (Fig 5.70). As the selected horizon is penetrated by at least three fracture zones the water sampled probably comes from the bedrock. However, due to the hydraulic gradient in the hole, open-hole effects will almost certainly result in water penetrating into and along the fractures in the sampled level. Thus, even though the water volume pumped out prior to sampling is more than 8 m^3 , it is no guarantee that a genuine water sample is obtained because the K-value is high and thereby it is possible that the amounts of water from the borehole activities may exceed that volume.

Table 5.20 The pH, Eh and redox-sensitive parameters recorded from the 100 ft depth in the 100 ft well.

DATE	DEPTH (ft)	PH	Eh (mV)	Fe(II) (mg/l)	O ₂ (mg/l)	S(-II) (mg/l)	I ⁻ (mg/l)
10/11/77	100	6.3	+270	2.8	1.11	0	0.002

The Eh values were measured using a platinum electrode and a silver/silver chloride reference electrode.

The Fe(II) values were measured using a colorimetric method.

The O₂ values were measured using a membrane electrode.

The I⁻ values were measured using a radiochemical method.

Water geochemistry

The sampled water (Table 5.20) recorded a pH of 6.3; the major cation (Na⁺ and Ca²⁺) and anion (HCO₃⁻ and Cl⁻) contents are much lower than normal non-saline groundwater compositions expected from this depth in the bedrock. The sampled water is undoubtedly of surface to near-surface origin and devoid of any significant amounts of drilling water tracer (0.002 % I⁻).

Redox-sensitive parameters

A strongly oxidising groundwater is indicated by the measured parameters i.e. positive Eh (+270 mV), significant oxygen (1.11 mg/l) and negligible S(-II); surprisingly the Fe(II) is present in appreciable amounts (2.8 mg/l).

Isotope geochemistry

No stable isotope or ¹⁴C data are available for this level. Tritium is present in moderate amounts (20 TU) which confirms a large surface to near-surface component.

Uranium geochemistry

The dissolved uranium content is low (0.04 ppb) and isotopic disequilibrium is widespread ($^{234}\text{U}/^{238}\text{U} = 2.4$).

Summary

Because of the lack of hydrological data from the borehole and due to the very high fracture density of the bedrock, it has been impossible to calculate the effects of the borehole activities on the quality of the sampled groundwater. The chemical parameters, however, point strongly to a surface or near-surface origin to the groundwaters. A combination of low pH, below average concentrations of the major ions, positive Eh values, high oxygen content and very low dissolved uranium, all support a near-surface origin. The possibility of a small deeper water component should not be overlooked and may in fact explain the lower than expected tritium (20 TU) when compared with typical surface waters from the Kamlunge area (approx. 35 TU).

The groundwater sampled has been pumped into the section from higher, more oxygenated levels via the highly conductive fracture system present in the bedrock, with limited mixing with more representative groundwaters in the near-vicinity of the borehole. Sampling of near-surface derived drilling water from above the borehole has also probably occurred. This may clarify the significant Fe(II) content (2.8 mg/l) present in the water.

The uranium content of the single groundwater sample is 0.02 ppb. This content, together with the theoretical Eh values calculated for the iron system, are presented in Table 5.21 and Figure 5.71. The figure also contains theoretical uranium solubility curves calculated from crystalline and amorphous UO_2 for a pH of 6.20 which is

close to that of the sampled groundwater. The groundwater composition lies within the amorphous uranium stability boundary.

Table 5.21 Uranium content and the theoretical Eh value of the groundwater from borehole Km 8.

Level (metres)	Uranium content (ppb)	Calculated Eh (mV)
238 - 240	0.04	+14

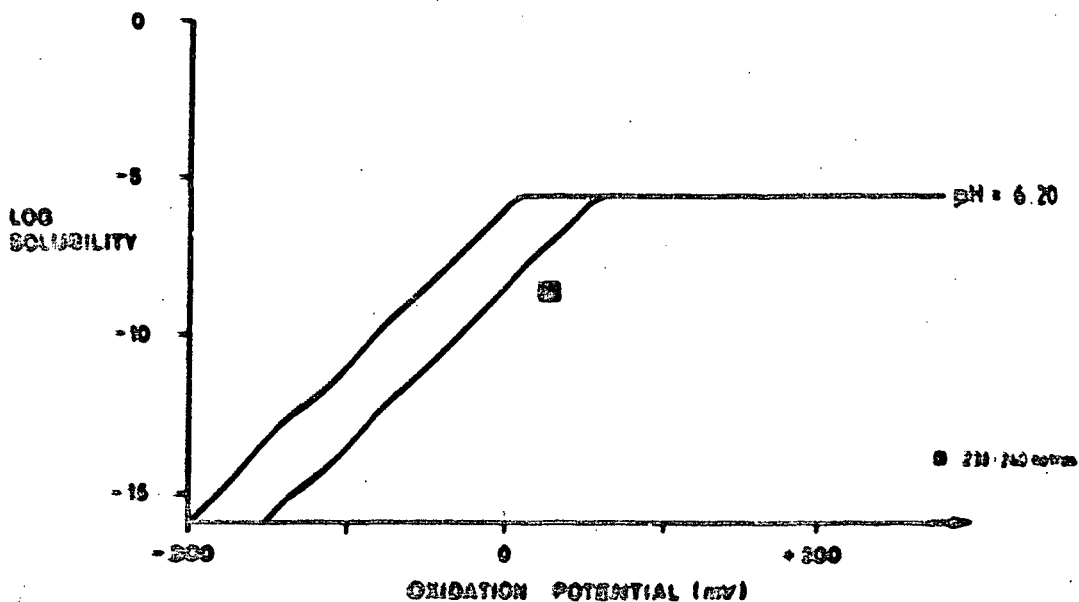

Figure 5.71: Plots of uranium content (expressed as log (mol/litre)) and the calculated theoretical Eh values of groundwaters collected from borehole Km 8. The values are plotted with respect to theoretical uranium solubility curves calculated for amorphous (lower stability limit) and crystalline (upper stability limit) UO_2 at a pH of 6.20.

5.5 Taavinunнанen

The Taavinunнанen test-site is situated in the county of Norrbotten some 35 km ENE of Kiruna and 170 km north of the arctic circle (Fig 1). The area, which constitutes a gabbro massif, forms a topographically distinct hill reaching above the timber line with its highest point at 780 m above sea-level. The last land ice moved in a NE direction resulting in a gentle slope on the SW side of the hill and a more rugged scarp on the NE side. Consequently most of the outcrop is located around the hill summit and NE slope. Moraine, however, covers most of the gabbro; at the drill site this achieves a thickness of 17.5 m. The altitude difference between the gabbro summit and its margins is 250 m in the NW and 400 m in the SE.

The regional geology of the area has been previously described by Melin (1970), Gulson (1972), Eriksson and Hallgren (1975), Hallgren (1979) and Ambros (1980). As a result of SKB investigations carried out over the period 1981-1983 the detailed geology of the Taavinunнанen test-site has been described by Ahlborn et al (1980), Henkel (1981), Ahlborn et al (1982), Gentszschin (1983b), Albino (1984), Larson et al (1984), Larson and Tuulborg (1984) and Gentszschin et al (1985). Most of the following description of the geological characteristics of the gabbro-massif is taken from Gentszschin et al (1985).

A map of the Taavinunнанen test-site area showing the general geological features and the main structural zones of weakness, is illustrated in Figure 5.72. The geology of the area is dominated by a gabbro massif of Proterozoic age. It is included in the younger series of plutonic rocks in the area which consists of pegmatite, aplite, granite, perthite-monzonite, syenite, gabbro and anorthosite, and is regarded as the last major plutonic event within the area. The series has been dated to about 1600 Ma; older rocks include quartzites, metadolerite,

limestone and tuffite. The gabbro massif itself is lopolithic in shape and represents a differentiated magma sequence of tholeiitic character with a composition which varies from pyroxenite to gabbroic in type due to a rhythmic layering as well as multiple magma intrusions. The thickness of the layers varies from some millimetres to several tens of metres and generally dip at angles ranging from $10-40^{\circ}$ towards the centre of the massif. The major mineralogical components are plagioclase (0-75 vol %), clinopyroxene (0-90 vol %), olivine (0-30 vol %) and magnetite (0-20 vol %). Orthopyroxene occurs rarely mostly as a secondary mineral. Clinopyroxene is the dominating mafic mineral in the gabbro and high density samples correspond to a significant magnetite content. Secondary mineral alteration usually occurs in and around the fracture zones.

Structurally the Taavinuonnen gabbro is characterised by short, steep NE to NNE striking fractures, which are part of the regional trend. Some fractures with more gentle dips occur parallel to the igneous layering. Evidence of faulting within the massif is observed as disturbances of the magnetic pattern and breaks in chemical trends of the gabbro. Surface studies show mylonitisation and brecciation along some of the fracture zones. From drillcore studies in the area there is a dominance of steep fractures although zones with intense igneous layering tend to show an increased frequency of horizontal to subhorizontal fractures. The variation of fracture frequency with depth is fairly uniform with the most common range being 2.0-4.9 fractures/metre. The main fracture filling minerals are chlorite, calcite and smectite with more minor occurrences of prehnite and zeolites.

Hydrologically the gabbro massif is drained by the Vittangijoki and the Setkujoki towards the west and east respectively. These streams later meet the main water course, the Torne river, which controls a drainage basin of approximately 34,000 km².

The water balance of the Taavinunnen area has been estimated to be:

Adjusted precipitation	760-875 mm/year
Actual evaporation	200 mm/year
Run-off	560-675 mm/year

These values should be considered only as a guide, as direct meteorological measurements are impeded by the geographical isolation of the area. The nearest stations are located 16 to 37 km away and at much lower altitudes (i.e. about 300 m lower). A precipitation increase of 7 % and 15 % per 100 m for rain and snow fall respectively has been assumed and the orographical effect of the massif has also been taken into account. The precipitation is calculated for the 600 m level and the high run-off is supposed to represent the local drainage conditions.

The groundwater level, occasionally measured from the borehole (Ta 1), has been located 15 to 18 m below the ground surface. Recharge of groundwater occurs once a year; during the snow melting period the groundwater table rises from the lowest to the highest annual levels. The annual mean temperature of the groundwater in this part of Sweden is just above 2°C.

Topographically, Taavinunnen is a recharge area with local discharge occurring in small depressions. The general groundwater flow is circulated towards the valleys surrounding the area primarily in the absence of major fracture zones, granitic dykes of greater hydraulic conductivity, together with the rhythmic layering texture of the gabbro, may influence the regional groundwater flow.

5.5.1 Borehole Ta 1

Borehole Ta 1 was drilled at 85° to a vertical depth of 686 m (borehole length 700.80 m) in order to investigate the geological extent of the massif and to locate suitable conductive horizons for representative groundwater samples. Guided by geophysical investigations the hole was placed in an area of unfractured gabbro; the nearest major fracture zone was estimated to be about 70 m from the hole.

For the most part the drillcore represents a differentiated gabbro varying in composition from pyroxenite to gabbroic in type due to the rhythmic layering as well as multiple intrusions. The thickness of the layers vary from some millimetres to several tens of metres. Approximately 8 % of the drillcore consists of aplite and granite dykes; some solitary thin basic dykes are also present. Of the gabbro, some 14 % has been altered to a fine-grained biotite-rich rock which is almost always found within and around tectonically disturbed areas.

The frequency of fractures for the drillcore is considered normal (mean 3.9 fractures/metre) when compared to the other investigated test-sites already described. High fracture frequency occurs between 136-147 m, 220-235 m and 375-384 m which correspond mostly to those granite and aplite dykes. This illustrates the less competent nature of the dykes when compared with the gabbro. Furthermore, these broad dykes often represent horizons of enhanced hydraulic conductivity.

The general hydraulic conductivity along the borehole length is low (Fig 5.73b), especially in the uppermost 200 m where only one 25 m section has a K -value exceeding $1 \cdot 10^{-8}$ m/s. Below 200 m about 60 % of the sections have a K -value lower or near the measuring limit ($K = 5 \cdot 10^{-12}$ m/s) and only three sections are greater than $1 \cdot 10^{-10}$ m/s. Water injection tests along 2 m sec-



Figure 5.73: Hydrogeological characteristics of borehole Ta 1.

- a) Fracture frequency (for 10 m sections) and the cumulative percentage of fractures
- b) Hydraulic conductivity
- c) Piezometric head distributions and hydrostatic head in the borehole

Table 5.22a. Measured hydraulic parameters and calculated water budget values of the various influences due to borehole activities of the water sampled levels in borehole Ta 1.

Level (m)	Deviation ^a (m)	Head deviation (borehole stands)	Flow direction (borehole stands)	Drilling water (+) (m ³)	Gas-lift pumping (-) (m ³)	Hydraulic seepage (+) (m ³)	Open hole effect before analysis (-) (m ³)	Sampled water before analysis (+) (m ³)
0-10	1.7 × 10 ⁻⁹	0.1	.	0.55	0.70	0.001	-1.20	10.25
10-20	3.1 × 10 ⁻¹¹	-	.	-0.001	-0.001	-0.001	?	5.5

^a 10 m sections head deviation from hydrostatic head in the borehole (in units of water).

Table 5.22b. Some cross-sectional parameters of groundwater sampled from the 0-10 section level in borehole Ta 1.

Parameter	Value	Unit	Parameter	Value	Unit	Parameter	Value	Unit
Temperature	12.5	°C	pH	7.5		Hardness	150	mg/L
Salinity	0.1	g/L	Electrical conductivity	150	µS/cm	Total dissolved solids	150	mg/L
Dissolved oxygen	8.5	mg/L	Total suspended solids	10	mg/L	Calcium	80	mg/L
Iron	0.1	mg/L	Chloride	10	mg/L	Magnesium	70	mg/L
Copper	0.01	mg/L	Sulfate	10	mg/L	Strontium	0.1	mg/L
Zinc	0.01	mg/L	Fluoride	0.1	mg/L	Barium	0.01	mg/L
Lead	0.01	mg/L	Ammonia	0.1	mg/L	Chlorine	0.1	mg/L
Cadmium	0.01	mg/L	Nitrate	0.1	mg/L	Bromine	0.01	mg/L
Mercury	0.01	mg/L	Phosphate	0.1	mg/L	Iodine	0.01	mg/L
Chromium	0.01	mg/L	Silicate	0.1	mg/L	Fluorine	0.01	mg/L
Manganese	0.01	mg/L	Aluminum	0.1	mg/L	Carbon	0.01	mg/L
Selenium	0.01	mg/L	Iron	0.1	mg/L	Hydrogen	0.01	mg/L
Vanadium	0.01	mg/L	Copper	0.01	mg/L	Helium	0.01	mg/L
Cobalt	0.01	mg/L	Zinc	0.01	mg/L	Neon	0.01	mg/L
Nickel	0.01	mg/L	Lead	0.01	mg/L	Argon	0.01	mg/L
Silver	0.01	mg/L	Cadmium	0.01	mg/L	Krypton	0.01	mg/L
Platinum	0.01	mg/L	Mercury	0.01	mg/L	Xenon	0.01	mg/L
Gold	0.01	mg/L	Chromium	0.01	mg/L	Radon	0.01	mg/L

Note: These analytical parameters were measured at the end of each sampling period, the reported values should therefore be the best representative for the groundwater at the depth of investigation.

- 1. Fracture density (FD) is the number of fractures per m² surface area
- 2. Deviation (m)
- 3. Hydraulic conductivity

tion and of 15 minutes duration have also been performed in the hole.

The results show that the most conductive sections of the hole mostly correspond to the granite dykes or within the gabbro adjacent to such dykes. The pressure conditions in the groundwater, illustrated in Figure 5.73c, give no satisfactory total picture of the piezometric head distribution along the borehole as many sections record a very low K-value. However, there may be a slight tendency of decreasing head with depth.

5.5.1.1 Level 496 - 498 m (approx. 493 m)

The sampled section is located within the gabbro which is dark-grey and fine-grained with poikilitic pyroxene porphyroblasts up to 2 cm in size. The section comprises one fracture zone (20 cm wide and containing 4 fractures) and nine single fractures. The intersection angles with the core axis range from 50° to 85° and the main fracture filling minerals are calcite, chlorite and smectite with lesser amounts of prehnite and zeolites.

Hydrology

The sampled level records a hydraulic conductivity of $1.7 \cdot 10^{-8}$ m/s along the 25 m section and a head deviation of +0.5 m. From injection tests along 2 m sections it is concluded that only 2 horizons conduct water and that the sampled level constitutes the dominant one. The considerable volume of water pumped out prior to sampling would seem to ensure a representative groundwater sample (Fig 5.74).

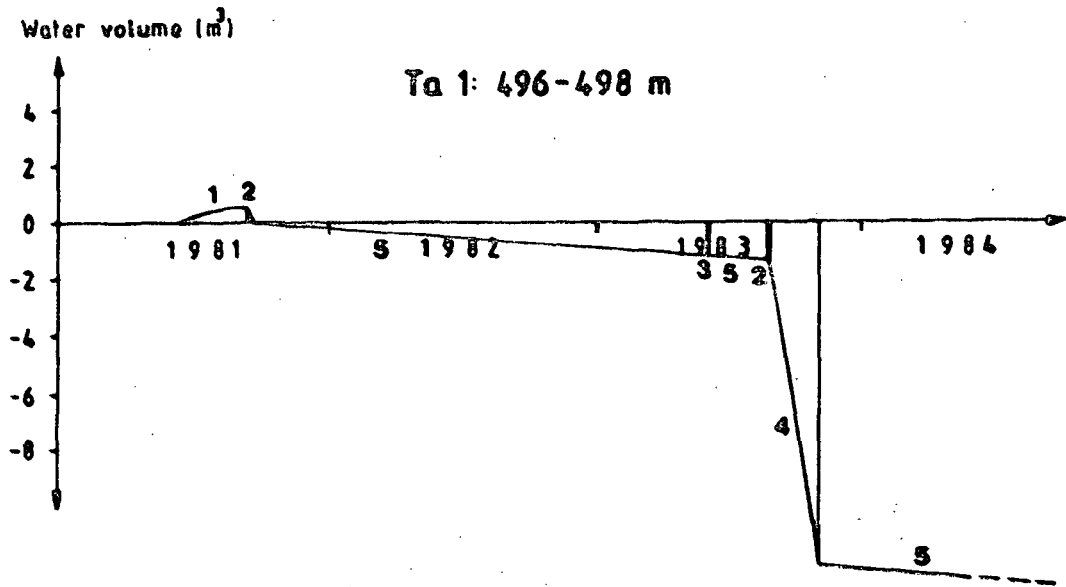

Figure 5.74: Schematic illustration of the calculated water budget for level 496-498 m in borehole Ta 1 (Taavinunnen). 1 = Drilling water; 2 = Gas-lift pumping; 3 = Hydraulic testing; 4 = Sampling; 5 = Open-hole effect.

Water geochemistry

The groundwater sample of pH = 9.1 (Table 5.22b) is characterised by a major ion content (Na^+ , Ca^{2+} , HCO_3^- and Cl^-) which is considerably lower than normal non-saline, intermediate to deep groundwaters, which might have been expected from this bedrock depth. The water is more typical of a near-surface origin.

Redox-sensitive parameters

The groundwater is oxidising ($E_h = +200 \text{ mV}$) and this is supported by an appreciable oxygen content (0.5 mg/l) and low to negligible amounts of Fe(II) and S(-II).

Isotope geochemistry

The stable isotope data ($\delta^{18}\text{O} = -13.66$ ppt and $\delta^2\text{H} = -97.6$ ppt) are in accordance with other groundwater samples of meteoric origin (Fig 5.6). The young ^{14}C age and the extremely high tritium value (123 TU) further emphasise that the sampled water is near-surface and recent in origin.

Uranium geochemistry

The dissolved uranium content of 0.59 ppb reflects the oxidising nature of the environment; no isotopic data are available.

Summary

The hydrological properties of the sampled level (reasonable hydraulic conductivity in combination with a positive piezometric head) should point to a representative groundwater sample from this level. The chemistry of the groundwater showed, however, a markedly oxidising water of near-surface origin (e.g. significant oxygen content and very high tritium contents). The possibility of drilling water contamination (and hence surface water contamination as the water source was a small surface lake) must therefore be considered. However, the high tritium content (123 TU), in comparison with to-days precipitation value of around 35 TU, shows that the water is some tens of years old and cannot therefore be solely from the drilling water source. If this water has been extracted from the fracture zone within the sampled section, then it indicates a very rapid groundwater circulation from the surface down to considerable depths. If the ^{14}C is to be relied upon, some mixing with older groundwater is suggested.

5.5.1.2 Level 654 - 656 m (approx. 651 m)

This level is characterised by fine- to medium-grained gabbro which contains poikilitic pyroxene porphyroblasts of similar size range. The section contains one crush zone some 15 cm wide comprising 4 fracture, and 4 single fractures. The intersection angle with the core axis ranges from 15-85° and the main filling mineral phases are calcite, chlorite and clay minerals.

Hydrology

The hydraulic conductivity along the 25 m section, which includes the sampled section, is $5.1 \cdot 10^{-11}$ m/s. The detailed injection tests show that only one 2 m section conducts water and this lies outside the sampled horizon (approx. 2 m below).

Water geochemistry

The sampled water is characterised by a pH of 9.2; as with the previous horizon, the major ion contents suggest a surface to near-surface origin to the groundwater.

Redox-sensitive parameters

Higher oxygen (0.62 mg/l) and Eh (+400 mV) values than the previous level indicate a more oxidising groundwater environment at these greater depths. Fe(II) and S(-II) are present in approximately the same amounts.

Isotope geochemistry

Stable isotope, ^{14}C and tritium data are similar to that of the previous level and thus support a young, near-surface meteoric source for the sampled water.

Uranium geochemistry

Dissolved uranium contents are fairly high (1.52-1.54 ppb) and the $^{234}\text{U}/^{238}\text{U}$ activity ratio is 2.2 which indicates disequilibrium in the groundwater environment.

Summary

There is little difference between this level and the previous one. What is perhaps surprising is the increased oxidising character of the water at greater depths. A large component of the water must therefore be surface to near-surface in origin and constitutes the borehole water which has been pumped round the packer system into the sampled section. This is supported by the hydrologic properties of the section which indicated that it was non-conductive.

5.5.1.3 Borehole summary and discussion

Considering the geochemical properties of the gabbro massif, the depth of sampling, and the relatively normal fracture frequency of the bedrock, intermediate to deep groundwaters of a reducing to a very reducing character would have been expected. In strong contrast, however, the sampled waters are characteristically oxidising with a chemistry and isotopic signature typical of a surface to near-surface origin. Taking into consideration the hydrologic properties of the two levels, the uppermost level was sufficiently conductive (with a positive piezometric head) to have been representative, the lower level, however, was non-conductive. It is important to note that this hole was drilled in 1981 and remained open until sampling was carried during 1983. There was therefore ample opportunity for borehole groundwater mixing to occur and also for the partial removal of any residual drilling water component by natural flushing.

On commencement of sampling and following gas-lift pumping, the accumulated borehole water will probably have originated from the higher, more conducting horizons, and will therefore be oxidising and high in tritium. The very high tritium contents recorded from both levels indicates that near-surface accumulation of slightly older groundwater (e.g. about 10-20 years old) has occurred and been retained at shallow levels thus reflecting the impermeable nature of the gabbro massif.

To conclude, the sampled water is typical of a young, surface to near-surface source and has quickly accumulated within the borehole. The two sections selected for sampling had not a sufficiently high groundwater capacity with the result that a partial vacuum was established within the section being sampled. This has led to a leakage of borehole water round the packer system into the section. The two groundwater samples are therefore not representative for the levels investigated.

However, markedly reduced and more representative groundwaters have been collected from the 494-496 m level (Smellie, 1983c). This study, which was carried out after the normal sampling period, and described in more detail below (Appendix 3), employed a much reduced pump flow-rate. This meant that the new pumping rate was able to accommodate the groundwater capacity of the fracture zone, so that compensating water was not forced into the sampled section from the borehole. This demonstrates that the higher level was hydraulically conducting as initially predicted by the water budget calculations.

The uranium content of the groundwater samples varies from 0.59-1.54 ppb with higher amounts being recorded from the lower horizon. The uranium content of the water, together with the theoretical Eh values calculated from the iron content of the water, are presented in Table 5.23 and Figure 5.75. The Figure also contains theoretical uranium solubility curves calculated from

crystalline and amorphous UO_2 for a pH of 9.50. The groundwater from the 496-498 m level plots just above the calculated crystalline stability limits.

Table 5.23 Uranium content and theoretical Eh value of the groundwater from borehole Ta 1.

Level (metres)	Uranium Content (ppb)	Calculated Eh (mV)
496 - 498	0.59	-292

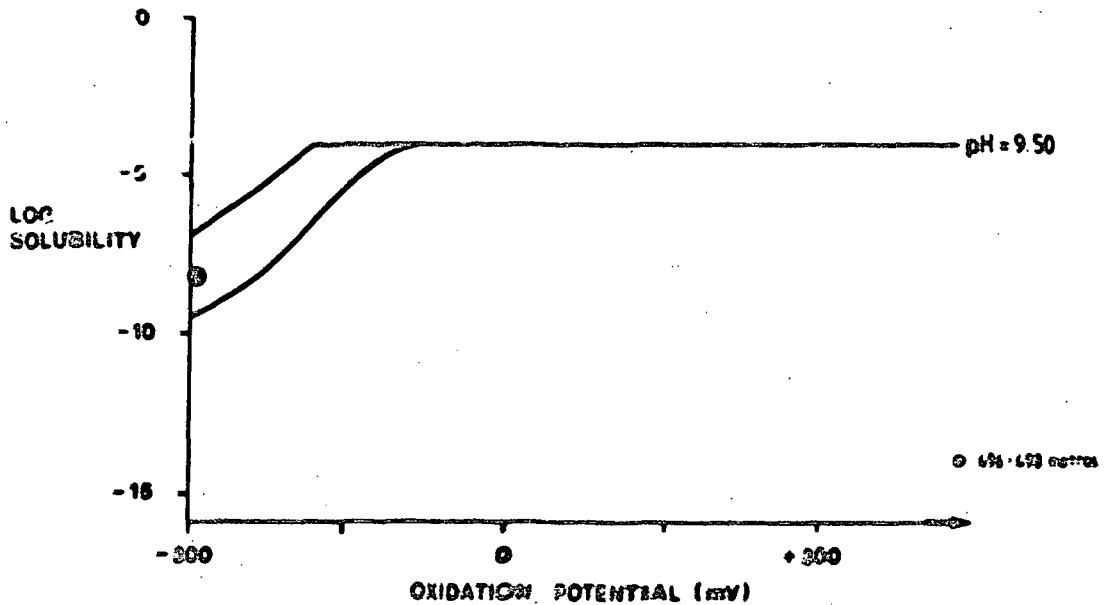

Figure 5.75: Plots of uranium content (expressed as log (mol/litre)) and the calculated theoretical Eh values of groundwaters collected from borehole Ta 1. The values are plotted with respect to theoretical uranium solubility curves calculated for amorphous (lower stability limit) and crystalline (upper stability limit) UO_2 at a pH of 9.50.

5.6 Klipperås

The Klipperås test-site is located in SE Sweden approximately 300 km south of Stockholm (Fig 1). The topography of the region is characteristically flat with an almost complete moraine cover which makes geological interpretation extremely uncertain; only a few weakly discerned lineaments are indicated. The surface expression of the geological features is therefore reliant mostly on ground geophysics and aerial/satellite photography together with borehole extrapolation.

The extremely flat nature of the topography is illustrated in Figure 5.76 which shows that the maximum altitude difference over a distance of 10 km from east to west is approximately 30 m, due to a gradual slope towards the east. The highest and lowest altitude points are 205 m and 160 m above sea-level respectively.

The regional geology of the Klipperås area has been previously described by Holst (1876, 1893), the Swedish Geological Survey (1960) and Åberg (1978). As a result of SKB investigations carried out in the years 1982-1984, the detailed geology of the area has been described by Olkiewicz, Magnusson, Tirén and Stejskal (1984).

Because of the virtual absence of outcrop in the area (those that do exist occur mostly in the western part) no detailed geological maps are available. However, based on geophysical interpretation a tentative structural map, together with the proposed distribution of dolerite dykes, is presented in Figure 5.77. The rock-types which dominate the area are magmatic and two main varieties exist: the Sömland granite and porphyry. These have been dated by Åberg (1978) to 1690 Ma for the granite and 1645 Ma for the porphyry; there is a possibility that the porphyry at Klipperås may be somewhat older. Here the granite has intruded the porphyry and normally the contact between the two is parallel to the volcanic

layering and scistosity within the porphyry; occasionally the granite has penetrated through the structural alignment. The porphyry is composed mainly of lava of variable acidity, together with intercalations of volcanoclastic sediment. As mentioned above it is strongly sheared and the volcanoclastic fragments have been deformed parallel to the regional structural trend. The granite, in contrast, is coarse-grained and massive, showing only a sporadic strong deformation fabric. From geophysical data, a steeply dipping dolerite dyke, about 80 m wide, occurs in the western part of the test area.

Because of the near absence of surface outcrop, geophysical investigations have been an important part of the test-site studies. As illustrated in Figure 5.77 three dolerite dykes striking NNE-SSW have been detected. In addition, four strongly tectonised zones of weakness have been interpreted, three striking N-S and one NE-SW. Weaker tectonic zones, generally of similar strike to those just described, also occur within the area. Drilling has shown that many of these large-scale structures are near vertically inclined and are characterised by microbreccia, coarse breccia and highly mylonitised zones in the bedrock.

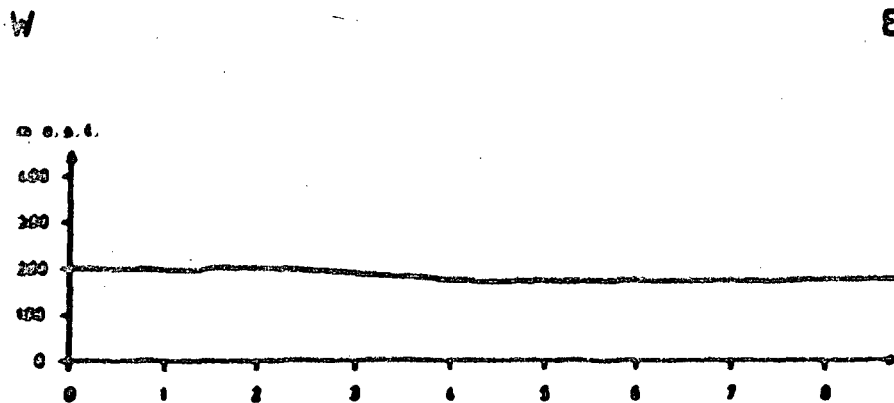

Figure 5.76: The Klippan test-site; topographic profile across the area.

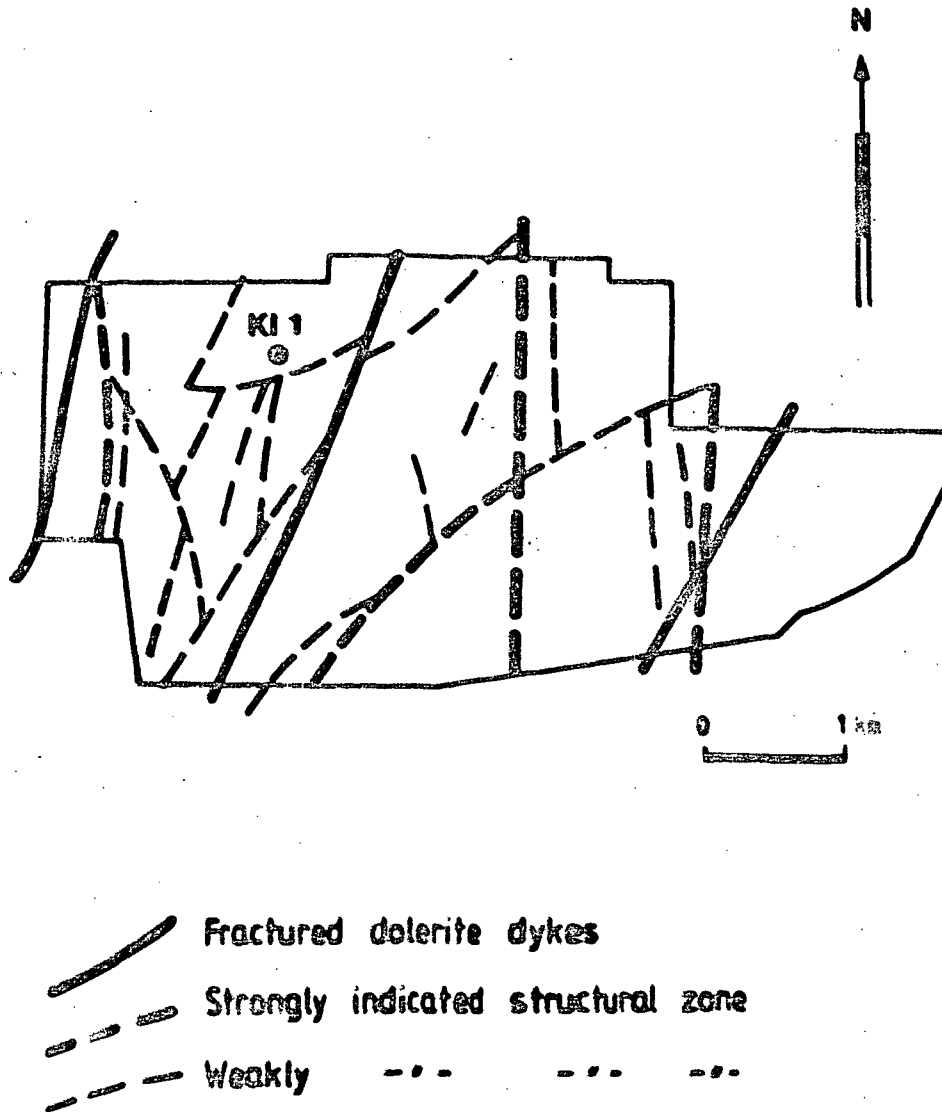

Figure 5.77: A tentative structural interpretation of the Klipperås test-site. Included are the major dolerite dykes and the location of borehole KI 1.

Hydrologically the Klipperås test-site is located in the catchment of the Ljungbyån stream (approx. 400 km²) and drains eastwards via smaller streams into the main water-course. The area, which is situated along the eastern slopes of the Småland highlands, does not appear to be either recharging or discharging. The frequent presence of peatbogs especially on the western and central parts at least indicate that local discharge areas occur.

A rough estimate of the water balance on a regional scale during the period 1931-1960 shows:

Adjusted precipitation	750 ± 50 mm/year
Actual evaporation	475 ± 25 mm/year
Run-off	275 ± 25 mm/year

These values have been extrapolated from maps showing the mean values for run-off, precipitation, and evaporation (Eriksson, 1980). Local physical conditions may affect these factors.

The groundwater level has been registered a few times from borehole Kl 1 and found to oscillate between 3.2 - 3.4 m below the ground surface. The seasonal variation of the groundwater level in this part of Sweden generally shows a single minimum and maximum value during the year. The minimum value coincides with late summer and the main period of groundwater recharge is during the autumn; this is prolonged by the short mild winter so that the maximum levels occur in spring. The annual mean temperature of the groundwater is about 7°C.

5.6.1 Borehole K1 1

Borehole K1 1 was drilled at 80° to a vertical depth of approx. 555 m (borehole length 563.95 m) to make a preliminary evaluation of the bedrock geology.

The dominant rock-type encountered is a medium- to coarse-grained homogeneous granite, red in colour and forms part of the so-called Värjö granite type. This is a quartz-rich microcline granite with varying amounts of plagioclase and little mafic content. Along the total length of the drillcore this granite accounts for 82 vol % followed by dolerite/greenstone (10 vol %), intermediate to acid volcanite (8 vol %) and lastly aplite (<1 vol %). The tectonic influence on the granite is observed as: 1) microfracturing of the granite, 2) alteration of feldspar to an iron-oxide fine-grained aggregate; complete alteration of the mafic constituents, 3) strongly mylonitised zones accompanied by a reduction in grain size and deformation of individual grains parallel to the regional foliation.

The volcanites are subdivided, on the basis of colour and macroscopic properties, into greenstone and intermediate to acid varieties. The acid type is dark-grey to grey-brown in colour, and is characterised by a dense matrix devoid of any notable phenocrysts. The greenstones are considered to be altered varieties of intermediate to basic volcanites. Occurring occasionally within the bedrock are fine-grained aplite dykes (up to 1.5 m wide) which show sharp contacts with the medium-grained granite.

Investigations of the fracture distributions within the borehole have revealed two distinct types of bedrock tectonics. Above 300 m the bedrock is characterised by horizontal to sub-horizontal fractures which are stress-release in origin. This contrasts with the lower borehole section which is dominated by steeply inclined fractures ($0-30^{\circ}$). Using 5 m sections the recorded

fracture frequency generally falls around 5 fractures/metre for the borehole as a whole. There are, however, three sections of high fracture frequency; at 25-30 m, 280-295 m and 450-564 m. In the uppermost zone iron-oxides and chlorite dominate as fracture filling minerals; there is a notable absence of calcite. In the intermediate zone chlorite and calcite dominate although iron-oxide does sporadically occur, and in the lowermost zone only chlorite and calcite occur.

The results of the hydraulic testing in this borehole diverge from those of most of the boreholes in the other test-sites (Fig 5.78b). The hydraulic conductivity is very high down to about 300 m whereupon it decreases markedly. The piezometric head in the upper conductive part of the borehole shows small deviation from the hydrostatic head (195 m above sea-level) in the borehole. The two sections exhibiting the highest excess pressure at depth are probably overestimated due to the uncertainty in determining the piezometric head at low K-values.

After several abortive attempts to sample adequate groundwater at decreasing depths from the hole bottom, a conductive section was finally located around the 406 m level. Using a single packer the borehole length from 410 m to the hole bottom was sampled.

5.6.1.1 Borehole length 406 m - hole bottom

This borehole length is characterised by roughly 50 % medium-grained, grey to red microcline granite, and the remaining 50 % is comprised of acid porphyry and greenstone horizons with thin zones of pegmatite and aplite intrusions. Generally the fracture frequency is low (Fig 5.78a) with an average of about 5 fractures/metre. The main infilling minerals are calcite, chlorite, epidote and muscovite.

Table 5.24a Measured hydraulic parameters and calculated water budget values of the various influences due to borehole activities at the water sampled levels in borehole K1 1.

Level in hole length	K-value (m/s)	Head deviation (m)	Flow direction (borehole trends)	Drilling water (+) (m ³)	Gas-lift pumping (-) (m ³)	Hydraulic testing (+) (m ³)	Open hole effect before sampling (2) (m ³)	Sampled water before analysis (-) (m ³)
20m-	3.2 x 10 ⁻¹¹	-		0.03	-0.001	-0.001	?	1.9

* Average of six 25 m sections

Table 5.24b

Level	Drilling water (+)	Gas-lift pumping (-)	Hydraulic testing (+)	Open hole effect before sampling (2)	Sampled water before analysis (-)
20m-	0.03	-0.001	-0.001	?	1.9

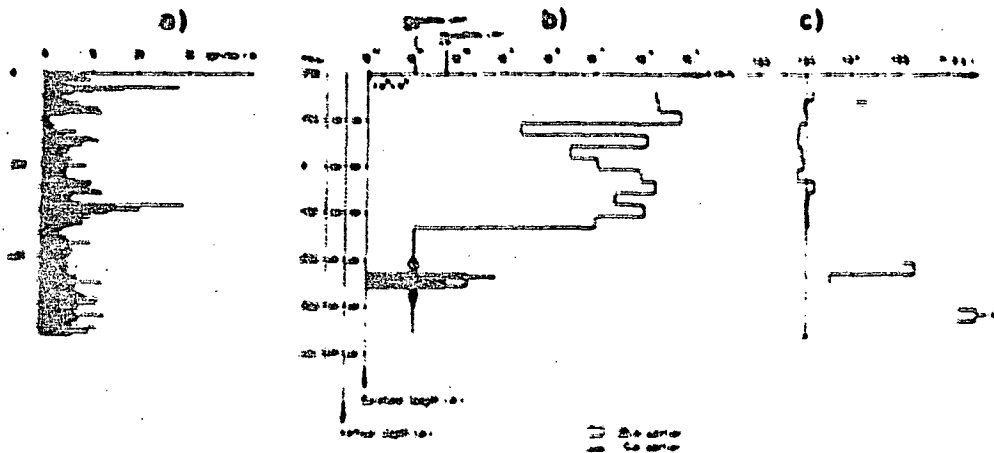

Figure 5.78: Hydrogeological characteristics of borehole K1 1.

- a) Fracture frequency for 5 m sections
- b) Hydraulic conductivity
- c) Piezometric head distribution and hydrostatic head in the borehole

Hydrology

It is clearly evident from Figure 5.78b that the most conductive section of the borehole is located at approximately 433-438 m depth. This is characterised by a K-value of $1.5 \cdot 10^{-10}$ m/s (measured along a 25 m section) and a positive piezometric head. Otherwise the borehole section sampled records K-values which are below the limit of measurement. The mean K-value for the sampled borehole length is $3 \cdot 10^{-11}$ m/s. The pumped volume is 1.9 m³ which is almost five times the borehole volume of the packed-off section.

Water geochemistry

The sampled water (average of 3 analyses) is characterised by a pH of 8.4; of the major cations, Na⁺ and Ca²⁺ are all present in appreciable but normal amounts for non-saline groundwater in crystalline bedrock, likewise for the major anions HCO₃⁻ and Cl⁻ (Fig 5.1). A complete absence of iodine shows that no mixing with drilling water has occurred.

Redox-sensitive parameters

Very negative Eh values (-300 mV) and an absence of oxygen indicate a markedly reducing environment. This is further supported by significant amounts of S(-II) (0.30 mg/l); only the total Fe content (0.06 mg/l) is available.

Isotope geochemistry

The stable isotope values ($\delta^{18}\text{O} = -12.11$ to -11.96 ppt and $\delta^2\text{H} = -86.5$ to -85.7 ppt) confirm a meteoric origin to the groundwater (Fig 5.6). The realistically old ^{14}C age (28 375 years) and the below detection amounts of tritium (< 3 TU) support the absence of any younger water component. .

Uranium geochemistry

The dissolved uranium contents are low (0.28 - 0.70 ppb) and the $^{234}\text{U}/^{238}\text{U}$ activity ratios high (5.58-6.05). These data would support a strongly reducing groundwater with long residency times to account for the build up of excess ^{234}U by alpha-recoil processes.

5.6.1.2 Borehole summary and discussion

Even though the groundwater sampling was carried out along the borehole length extending from approximately 406-564 m, hydrological considerations point to only one conducting level of any major importance. This is represented by a fracture horizon which intersects the borehole at approximately 433-438 m. It is thus reasonable to assume that the main portion of the sampled water has come from this zone, together with minor amounts of borehole water; the sampled water should therefore be suitably representative.

The chemistry of the groundwater conforms to an intermediate to deep non-saline water of a strongly reducing character. As indicated by the tritium and radiocarbon data, there is an absence of any young surface or near-surface component, and no detectable iodine tracer shows an absence of any drilling water component. However, the slightly higher than average conductivity values and chloride content (33.8-36.1 mS/m; Cl^- content of around 55 mg/l) may indicate limited mixing with quantities of deeper, more saline groundwaters.

The low uranium content supports a reducing groundwater environment. The uranium content of the groundwater, together with the theoretical Eh values calculated from the total iron content of the water, is presented in Table 5.25 and Figure 5.79. The Figure also contains

theoretical uranium solubility curves calculated from crystalline and amorphous UO_2 for a pH of 8.10. The groundwater from the 406 m-hole bottom length plots near the calculated amorphous UO_2 stability limit.

Table 5.25 Uranium content and theoretical Eh value of the groundwater from borehole K1 1.

Level (metres)	Uranium Content (ppb)	Calculated Eh (mV)
406 m -	0.28	-152

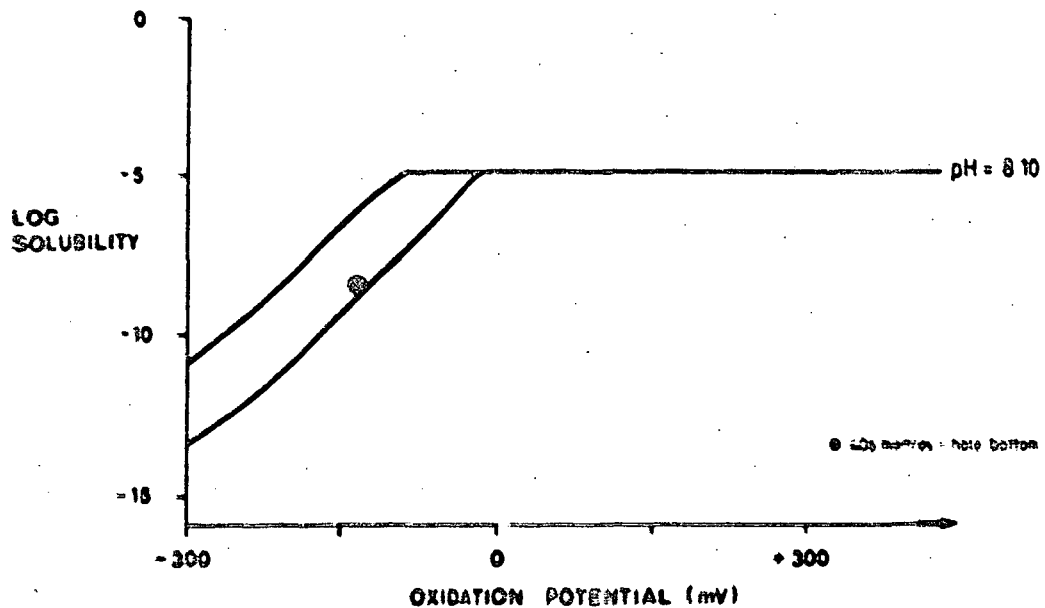

Figure 5.79: Plots of uranium content (expressed as log (mol/litre)) and the calculated theoretical Eh values of groundwaters collected from borehole K1 1. The values are plotted with respect to theoretical uranium solubility curves calculated for amorphous (lower stability limit) and crystalline (upper stability limit) UO_2 at a pH of 8.10.

6. DISCUSSION AND CONCLUSIONS

This report has compiled all the available hydrochemical and hydraulic data resulting from the SKB test-site investigations carried out over a period of 3 years (1982-84). By systematically applying hydrological and geological considerations to each sampled horizon, it has been possible to differentiate between those groundwaters which are reasonably representative for the depth sampled from those which have been subject to contamination from different sources. As a consequence, only a very few sampled horizons can be considered worth serious hydrochemical attention, and these are indicated in Table 6.1 and discussed below. The lack of representative groundwater samples, whilst often due to technical problems or sampling from non-conductive sections of the boreholes, also illustrate the extremely complex geometry of the permeable fracture systems in crystalline bedrock, and thus the difficulty of establishing the nature and depth relation of the groundwater reservoir tapped.

6.1 General Geological and Hydrogeological Features of the Representative Groundwater Horizons

The hydrological and geological features of the groundwater environment for the five representative samples are compared in Table 6.2 in an attempt to distinguish any shared characteristics that may prove useful in future investigations. For those borehole sections (e.g. Fj 2 and K1 1) which failed to include the conductive horizon that supplied the groundwater (eventually leaked around the packer system during sampling), the hydrogeological features of the conducting zone are also presented for a more realistic comparison.

Of the five representative horizons, four different test-sites are involved, ranging in bedrock composition from migmatite to granite. Within two of the migmatized

areas (e.g. Gideå and Svartboberget) dykes of granite/pegmatite composition characterise the bedrock either within or near the sampled sections. At only two sites (Fj 2 and Gi 4) have major local fracture zones been involved; generally, in all the horizons the intersecting fractures form angles greater than 30° to the core axes, although this is not considered especially significant.

It was expected that these representative horizons would be characterised by high hydraulic conductivity together with positive piezometric heads. This is the case for Gi 2 and Sv 4, and to a much better extent when Zone 4 is considered for Fj 2. Klipperås (Kl 1), however, presents a special case as the hydraulic conductivity is relatively low and the sampled section length is 158 m. Within this section there is only one conducting horizon at 443-438 m, which also records a positive head. Therefore, the successful extraction of representative groundwater from Klipperås was possible through the use of a much lower pump flow-rate than normal which apparently did not exceed the hydraulic capacity of the conducting zone. The Gi 4 sample is the most difficult to explain as the sampled horizon is located within the heavily fractured and strongly conducting Zone 3A. These fractures, together with a considerable negative pressure head, should have culminated in a strongly contaminated groundwater sample. However, this may be partly explained by an over-estimation of contamination in the water budget due to leakage during hydraulic testing resulting in an exaggerated k-value. On the other hand, if the water budget is valid, then the water sampled must have originated from areas of excess pressure in the bedrock. This water during open-hole conditions has displaced the contaminated water (resulting from drilling operations) further into the bedrock.

In conclusion, the five respective horizons have no significant geological or hydrogeological features in common which can be used as guidelines when selecting

Table 6.1

Sample No.	Depth (m)	Water Content (%)	Shrinkage (%)	Swelling (%)	Plasticity Index	Liquid Limit (%)	Plastic Limit (%)	Shrinkage Ratio	Swelling Ratio	Plasticity Chart	Soil Classification	Remarks
1	0-15	18.5	1.2	0.5	1.5	25.0	15.0	1.67	1.00	US	CL	
2	15-30	19.0	1.3	0.6	1.6	26.0	16.0	1.63	1.05	US	CL	
3	30-45	19.5	1.4	0.7	1.7	27.0	17.0	1.60	1.10	US	CL	
4	45-60	20.0	1.5	0.8	1.8	28.0	18.0	1.56	1.15	US	CL	
5	60-75	20.5	1.6	0.9	1.9	29.0	19.0	1.53	1.20	US	CL	
6	75-90	21.0	1.7	1.0	2.0	30.0	20.0	1.50	1.25	US	CL	
7	90-105	21.5	1.8	1.1	2.1	31.0	21.0	1.47	1.30	US	CL	
8	105-120	22.0	1.9	1.2	2.2	32.0	22.0	1.44	1.35	US	CL	
9	120-135	22.5	2.0	1.3	2.3	33.0	23.0	1.41	1.40	US	CL	
10	135-150	23.0	2.1	1.4	2.4	34.0	24.0	1.38	1.45	US	CL	
11	150-165	23.5	2.2	1.5	2.5	35.0	25.0	1.35	1.50	US	CL	
12	165-180	24.0	2.3	1.6	2.6	36.0	26.0	1.32	1.55	US	CL	
13	180-195	24.5	2.4	1.7	2.7	37.0	27.0	1.29	1.60	US	CL	
14	195-210	25.0	2.5	1.8	2.8	38.0	28.0	1.26	1.65	US	CL	
15	210-225	25.5	2.6	1.9	2.9	39.0	29.0	1.23	1.70	US	CL	
16	225-240	26.0	2.7	2.0	3.0	40.0	30.0	1.20	1.75	US	CL	
17	240-255	26.5	2.8	2.1	3.1	41.0	31.0	1.17	1.80	US	CL	
18	255-270	27.0	2.9	2.2	3.2	42.0	32.0	1.14	1.85	US	CL	
19	270-285	27.5	3.0	2.3	3.3	43.0	33.0	1.11	1.90	US	CL	
20	285-300	28.0	3.1	2.4	3.4	44.0	34.0	1.08	1.95	US	CL	
21	300-315	28.5	3.2	2.5	3.5	45.0	35.0	1.05	2.00	US	CL	
22	315-330	29.0	3.3	2.6	3.6	46.0	36.0	1.02	2.05	US	CL	
23	330-345	29.5	3.4	2.7	3.7	47.0	37.0	0.99	2.10	US	CL	
24	345-360	30.0	3.5	2.8	3.8	48.0	38.0	0.96	2.15	US	CL	
25	360-375	30.5	3.6	2.9	3.9	49.0	39.0	0.93	2.20	US	CL	
26	375-390	31.0	3.7	3.0	4.0	50.0	40.0	0.90	2.25	US	CL	
27	390-405	31.5	3.8	3.1	4.1	51.0	41.0	0.87	2.30	US	CL	
28	405-420	32.0	3.9	3.2	4.2	52.0	42.0	0.84	2.35	US	CL	
29	420-435	32.5	4.0	3.3	4.3	53.0	43.0	0.81	2.40	US	CL	
30	435-450	33.0	4.1	3.4	4.4	54.0	44.0	0.78	2.45	US	CL	
31	450-465	33.5	4.2	3.5	4.5	55.0	45.0	0.75	2.50	US	CL	
32	465-480	34.0	4.3	3.6	4.6	56.0	46.0	0.72	2.55	US	CL	
33	480-495	34.5	4.4	3.7	4.7	57.0	47.0	0.69	2.60	US	CL	
34	495-510	35.0	4.5	3.8	4.8	58.0	48.0	0.66	2.65	US	CL	
35	510-525	35.5	4.6	3.9	4.9	59.0	49.0	0.63	2.70	US	CL	
36	525-540	36.0	4.7	4.0	5.0	60.0	50.0	0.60	2.75	US	CL	
37	540-555	36.5	4.8	4.1	5.1	61.0	51.0	0.57	2.80	US	CL	
38	555-570	37.0	4.9	4.2	5.2	62.0	52.0	0.54	2.85	US	CL	
39	570-585	37.5	5.0	4.3	5.3	63.0	53.0	0.51	2.90	US	CL	
40	585-600	38.0	5.1	4.4	5.4	64.0	54.0	0.48	2.95	US	CL	
41	600-615	38.5	5.2	4.5	5.5	65.0	55.0	0.45	3.00	US	CL	
42	615-630	39.0	5.3	4.6	5.6	66.0	56.0	0.42	3.05	US	CL	
43	630-645	39.5	5.4	4.7	5.7	67.0	57.0	0.39	3.10	US	CL	
44	645-660	40.0	5.5	4.8	5.8	68.0	58.0	0.36	3.15	US	CL	
45	660-675	40.5	5.6	4.9	5.9	69.0	59.0	0.33	3.20	US	CL	
46	675-690	41.0	5.7	5.0	6.0	70.0	60.0	0.30	3.25	US	CL	
47	690-705	41.5	5.8	5.1	6.1	71.0	61.0	0.27	3.30	US	CL	
48	705-720	42.0	5.9	5.2	6.2	72.0	62.0	0.24	3.35	US	CL	
49	720-735	42.5	6.0	5.3	6.3	73.0	63.0	0.21	3.40	US	CL	
50	735-750	43.0	6.1	5.4	6.4	74.0	64.0	0.18	3.45	US	CL	
51	750-765	43.5	6.2	5.5	6.5	75.0	65.0	0.15	3.50	US	CL	
52	765-780	44.0	6.3	5.6	6.6	76.0	66.0	0.12	3.55	US	CL	
53	780-795	44.5	6.4	5.7	6.7	77.0	67.0	0.09	3.60	US	CL	
54	795-810	45.0	6.5	5.8	6.8	78.0	68.0	0.06	3.65	US	CL	
55	810-825	45.5	6.6	5.9	6.9	79.0	69.0	0.03	3.70	US	CL	
56	825-840	46.0	6.7	6.0	7.0	80.0	70.0	0.00	3.75	US	CL	
57	840-855	46.5	6.8	6.1	7.1	81.0	71.0	-0.03	3.80	US	CL	
58	855-870	47.0	6.9	6.2	7.2	82.0	72.0	-0.06	3.85	US	CL	
59	870-885	47.5	7.0	6.3	7.3	83.0	73.0	-0.09	3.90	US	CL	
60	885-900	48.0	7.1	6.4	7.4	84.0	74.0	-0.12	3.95	US	CL	
61	900-915	48.5	7.2	6.5	7.5	85.0	75.0	-0.15	4.00	US	CL	
62	915-930	49.0	7.3	6.6	7.6	86.0	76.0	-0.18	4.05	US	CL	
63	930-945	49.5	7.4	6.7	7.7	87.0	77.0	-0.21	4.10	US	CL	
64	945-960	50.0	7.5	6.8	7.8	88.0	78.0	-0.24	4.15	US	CL	
65	960-975	50.5	7.6	6.9	7.9	89.0	79.0	-0.27	4.20	US	CL	
66	975-990	51.0	7.7	7.0	8.0	90.0	80.0	-0.30	4.25	US	CL	
67	990-1005	51.5	7.8	7.1	8.1	91.0	81.0	-0.33	4.30	US	CL	
68	1005-1020	52.0	7.9	7.2	8.2	92.0	82.0	-0.36	4.35	US	CL	
69	1020-1035	52.5	8.0	7.3	8.3	93.0	83.0	-0.39	4.40	US	CL	
70	1035-1050	53.0	8.1	7.4	8.4	94.0	84.0	-0.42	4.45	US	CL	
71	1050-1065	53.5	8.2	7.5	8.5	95.0	85.0	-0.45	4.50	US	CL	
72	1065-1080	54.0	8.3	7.6	8.6	96.0	86.0	-0.48	4.55	US	CL	
73	1080-1095	54.5	8.4	7.7	8.7	97.0	87.0	-0.51	4.60	US	CL	
74	1095-1110	55.0	8.5	7.8	8.8	98.0	88.0	-0.54	4.65	US	CL	
75	1110-1125	55.5	8.6	7.9	8.9	99.0	89.0	-0.57	4.70	US	CL	
76	1125-1140	56.0	8.7	8.0	9.0	100.0	90.0	-0.60	4.75	US	CL	
77	1140-1155	56.5	8.8	8.1	9.1	101.0	91.0	-0.63	4.80	US	CL	
78	1155-1170	57.0	8.9	8.2	9.2	102.0	92.0	-0.66	4.85	US	CL	
79	1170-1185	57.5	9.0	8.3	9.3	103.0	93.0	-0.69	4.90	US	CL	
80	1185-1200	58.0	9.1	8.4	9.4	104.0	94.0	-0.72	4.95	US	CL	
81	1200-1215	58.5	9.2	8.5	9.5	105.0	95.0	-0.75	5.00	US	CL	
82	1215-1230	59.0	9.3	8.6	9.6	106.0	96.0	-0.78	5.05	US	CL	
83	1230-1245	59.5	9.4	8.7	9.7	107.0	97.0	-0.81	5.10	US	CL	
84	1245-1260	60.0	9.5	8.8	9.8	108.0	98.0	-0.84	5.15	US	CL	
85	1260-1275	60.5	9.6	8.9	9.9	109.0	99.0	-0.87	5.20	US	CL	
86	1275-1290	61.0	9.7	9.0	10.0	110.0	100.0	-0.90	5.25	US	CL	
87	1290-1305	61.5	9.8	9.1	10.1	111.0	101.0	-0.93	5.30	US	CL	
88	1305-1320	62.0	9.9	9.2	10.2	112.0	102.0	-0.96	5.35	US	CL	
89	1320-1335	62.5	10.0	9.3	10.3	113.0	103.0	-0.99	5.40	US	CL	
90	1335-1350	63.0	10.1	9.4	10.4	114.0	104.0	-1.02	5.45	US	CL	
91	1350-1365	63.5	10.2	9.5	10.5	115.0	105.0	-1.05	5.50	US	CL	
92	1365-1380	64.0	10.3	9.6	10.6	116.0	106.0	-1.08	5.55	US	CL	
93	1380-1395	64.5	10.4	9.7	10.7	117.0	107.0	-1.11	5.60	US	CL	
94	1395-1410	65.0	10.5	9.8	10.8	118.0	108.0	-1.14	5.65	US	CL	
95	1410-1425	65.5	10.6	9.9	10.9	119.0	109.0	-1.17	5.70	US	CL	
96	1425-1440	66.0	10.7	10.0	11.0	120.0	110.0	-1.20	5.75	US	CL	
97	1440-1455	66.5	10.8	10.1	11.1	121.0	111.0	-1.23	5.80	US	CL	
9												

suitable sampling sections in the future. It would thus appear that every area has its own distinct hydrogeological signature which in turn reflects the physical properties of the bedrock and the fracture geometry resulting from regional tectonic influences.

6.2 General Hydrochemical Characteristics of the Groundwaters

Even though many of the collected groundwaters are not representative for the depth sampled, their surface, near-surface and intermediate to deep origins, can usually be determined. As a result, a fairly clear impression of the general chemistry as a function of depth can be ascertained.

The groundwaters show expected trends in chemical composition as a function of depth (see Section 2.2.1). For example, there is a general decrease in Ca^{2+} and HCO_3^- and a corresponding increase in Na^+ and Cl^- with depth; this is also accompanied by an increase in pH. An increasingly reducing environment is indicated by negative Eh values, an absence of oxygen, lower contents of dissolved uranium, and sometimes the presence of small but significant quantities of Fe(II) and/or S(-II). The absence of any marked contamination from young, surface to near-surface waters, or drilling water, is indicated by very low to negligible tritium and iodine levels. It is important to note, however, that high iodine levels are sometimes present as natural background levels in the more saline groundwaters.

As emphasised in Section 2.2.3., groundwater isotopic compositions should at best be used as 'signs-posts' when interpreted in isolation; certain isotopes (e.g. ^{14}C) when considered individually can be fraught with uncertainty. Used collectively, much more qualitative to semi-quantitative information can be obtained. Of particular use in this respect has been the pairing of tritium with ^{14}C , with constructive support from the

$^{234}\text{U}/^{238}\text{U}$ activity ratios (discussed below). In general, high tritium (i.e. young, surface to near-surface water) has been equated with young ^{14}C ages, and old waters (absence of tritium) give correspondingly old ^{14}C ages. The mixing of groundwaters from different sources has been qualitatively evaluated by relating low to moderate tritium contents to varying 'dilution' degrees of the ^{14}C data accordingly.

The stable isotope data indicate a predominantly meteoric origin to the groundwaters, even those which are anomalously saline in character (e.g. Fj 2, level 605 m and Gi 4, levels 404 m and 616 m). Small depletions of $\delta^{18}\text{O}$ and $\delta^2\text{H}$ help to distinguish the more saline varieties.

Within the investigated test-site areas one of the present drawbacks of groundwater isotope interpretation, and hydrochemical evaluation as a whole, is the absence of a regional pattern. For example, most of the waters analysed are collected from shallow to deep hole locations and there exists little information of the regional recharge/discharge groundwater compositions to put the borehole data into a larger-scale perspective. To some extent this has been attempted by Tullborg and Winberg (1985), who have compared the $\delta^{18}\text{O}$ of the precipitation with that of the deep groundwaters from each of the investigated areas. Their conclusions indicated that there was a corresponding agreement between relevant $\delta^{18}\text{O}$ values from discharge areas with those calculated from the precipitation. To complement these data, and as a valuable aid to the general hydrochemical investigations, it is recommended that a programme of surface to near-surface sampling (e.g. to include sampling from percussion boreholes used in the hydrogeological studies) based on a regional hydrogeological model should be carried out to facilitate eventual evaluation at depth, and help to put into

perspective the more localised recharge/discharge conditions which characterise each test-site area.

A cautionary mention should be made about hydrochemical investigations from recharge and discharge areas. In the former areas representative recharge waters are easily accessible at fairly shallow depths, and in sufficiently large volumes. In the latter case, however, discharge water initially originating from depth and sampled near the surface will represent a mixture of different groundwater sources and ages accumulated during its upward passage through the bedrock. Such waters are best sampled at depth, before upward circulation has incorporated groundwater from other sources. One disadvantage is that only small volumes will be available and careful sampling techniques are therefore necessary.

6.3 Groundwater Redox Conditions and the Geochemical Behaviour of Uranium

The behaviour of uranium in groundwater is mostly a function of pH, Eh and the total concentrations of the ligands which form complexes of relative strength with uranium in its different oxidation states, i.e. carbonate, dihydrogen phosphate etc (see section 2.2.2). Measurements of pH, Eh and the most important ligand, carbonate, form part of the hydrochemical data presented in this report. However, because of the sizeable degree of groundwater contamination encountered, only the data from five horizons can be used (Table 6.1), although the chemical properties of surface, and near-surface waters, which have given rise to some of the contamination, can also be used. From the available data, the following general bedrock groundwater redox trends can be observed:

- increasingly reducing conditions are encountered with depth (i.e. decrease in Eh, O_2 ; increase in Fe(II), S(-II) and pH).

- the dissolved uranium content decreases sympathetically with increasing reducing conditions.
- oxidising waters are characterised by significant uranium contents and $^{234}\text{U}/^{238}\text{U}$ activity ratios of around 2.0-3.0; highly reducing groundwaters are uranium depleted and exhibit high activity ratios from 3.0-8.0.

Of course this generalised pattern is locally disturbed and modified by deep, highly conductive fracture/crush zones, which can serve to allow less reducing groundwater to penetrate to considerable depths.

As discussed by Wikberg et al (1983), the redox conditions of the groundwater can be qualitatively described by the contents of oxygen, iron and sulphide. Oxidising groundwaters contain dissolved oxygen, whilst the presence of iron and sulphide suggest reducing conditions. However, because of the difficulty in obtaining an air-free environment during the sampling operations, the amount of oxygen monitored in the flow-through cell is generally not representative of the groundwater, but rather the result of oxygen contamination from the atmosphere. A much more quantitative grasp of the true redox conditions can be achieved from the measured and theoretically calculated Eh and the amount of dissolved uranium. There is, however, a large variation observed between measured and calculated Eh due to the experimental difficulties referred to above. The measurements are disturbed by atmospheric oxygen to the extent that the electrodes require a considerable time to stabilise following calibration. In most of the test-site investigations there has been inadequate time for stabilisation between calibration halts, resulting in Eh measurements which are higher than should be expected in the absence of oxygen. To rectify this problem the frequency of electrode calibration during sampling at Klipperås (K1 1) was drastically reduced so that a stable monitoring plateau was achieved. From Table 6.3 it can be noted that the

groundwater, besides having a very negative Eh, exhibits a measured Eh which is even lower than the calculated value. Subsequent investigations have supported these findings (Wikberg, 1985) indicating that the simple Eh model used for calculation purposes is inadequate.

Table 6.3: Redox-sensitive parameters and pH for representative reducing and oxidising groundwaters from the SKB Test-sites.

Borehole	Level (metres)	pH	U (ppb)	Eh _m (mV)	Eh _t (mV)
FJ 2	605	8.9	<0.2	-115	-250
Gi 2	178	7.7	0.23	-100	-218
Gi 4	222	9.0	0.98	-120	-268
Sv 4	376	9.6	0.22	-140	-355
Sv 5	160	7.7	44.5	+120	-
Km 3	123	7.9	24.3	+100	-
Kl 1	403	8.4	0.68	-300	-152

Eh_m = monitored Eh in the flow-through cell

Eh_t = theoretically calculated Eh

The relationship between uranium content and the theoretically calculated groundwater Eh has been already presented for each borehole from each of the described test-sites. However, it should be pointed out that thermodynamic data, when considered, is only valid on groundwater data which represent equilibrium conditions. Consequently, the following discussion is based mostly on those groundwater samples considered representative in Table 6.1. Figure 6.1 illustrates the position of these reducing groundwater compositions, together with the uranium (IV) and uranium (VI) stability field systems based on Eh - pH criteria. It can be clearly seen that all the reducing groundwaters plot within the stability field of uranium (IV) whereas the truly oxidising waters,

as expected, plot within the uranium (VI) field. Furthermore, from Table 6.3 the uranium content of the oxidising groundwaters is seen to be far in excess of the reducing varieties where the concentrations are limited by the solubility of the uranium oxide phase. Because of the Eh range for each sample, and the lack of any mineralogical data, the nature of these limiting UO_2 phases (i.e. amorphous vs crystalline) is unfortunately not known, although, as suggested by Andrews and Kay (1983), "crystalline UO_2 boundaries are appropriate for groundwater equilibration with rock matrices containing well-crystallised UO_2 , as for example in some granitic (i.e. crystalline bedrock) environments":

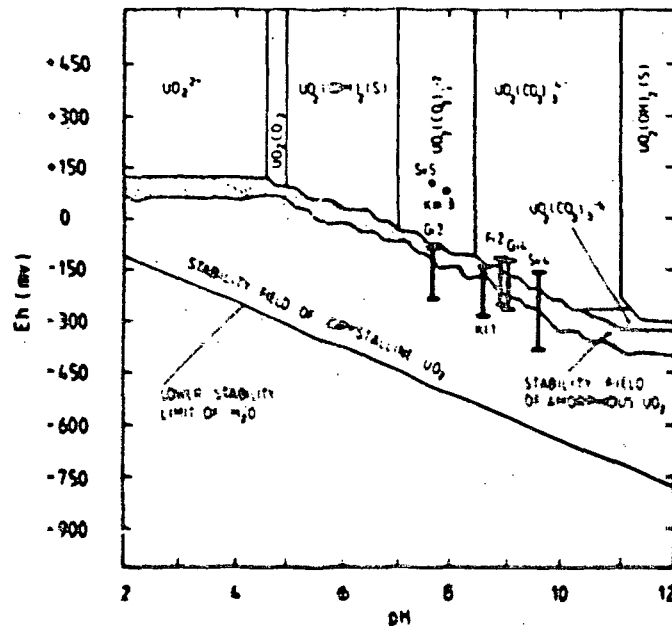

Figure 6.1: Eh-pH diagram showing the stability fields of the more important U (VI), U (V) and U (IV) complexes considered relevant to groundwater compositions from crystalline bedrock environments in Sweden. The choice of thermodynamic parameters is summarised and discussed by Bruno et al (1984). Uranium boundaries are shown for equilibria with crystalline UO_2 (lower boundary) and with amorphous UO_2 (upper boundary).

As previously noted, the marked depletion of dissolved uranium in strongly reducing groundwaters appears to be accompanied by an increase in the $^{234}\text{U}/^{238}\text{U}$ activity ratios caused by a build-up of excess ^{234}U . This is in accordance with other studies mostly carried out in sedimentary aquifer systems (Osmond and Cowart, 1976; Andrews and Kay, 1982). Osmond and Cowart (1974) suggested that such a build-up of ^{234}U with depth indicates an aging effect due to the natural decay of the parent ^{238}U . However, as pointed out by Andrews et al (1982), uranium in solution does not form a closed system and ingrowth of ^{234}U occurs due to solution of alpha-recoil ^{234}Th at the rock/water interfaces during permeation of the groundwaters through the bedrock. The inference, therefore, from these representative groundwater data is that the groundwaters are moving sufficiently slowly through the bedrock at depth so as to allow a ^{234}U excess to accumulate. These groundwaters would therefore be expected to originate from low conducting horizons within the bedrock and be of considerable age. As discussed above, and excluding Klipperås which does in fact record a low hydraulic conductivity, the remaining four suitably sampled horizons are actually characterised by hydraulic conductivities in excess of $6.5 \cdot 10^{-9}$ m/s. However, in all cases with available ^{14}C data, the recorded ages are in fact significantly old, ranging from 11895 - 28375 years.

6.4 Hydrological Models

Throughout the report continual reference has been made to the general groundwater flow-pattern in the vicinity of the various boreholes examined. These flow-patterns have been derived from the numerical modelling as described by Carlsson et al (1983). The question can be posed as to what practical use is the actual numerical model in the interpretation of hydrochemical data?

The model employed in this study, in common with other models of similar type, are limited by the amount of geological and hydrological information that can be processed. As a consequence, the characteristic hydrogeological properties of an area must be suitably simplified to accommodate the capacity of the numerical model program. For example, the bedrock is simplified into three units: the rockmass, regional fracture zones, and local fracture zones. The rockmass constitutes the normal, fractured bedrock, located between the two major types of fracture zones. If the model requires, the rock mass can be considered as a single hydraulic unit irrespective of geological heterogeneities (e.g. widely differing bedrock composition and therefore competency) which could result in different hydraulic properties. In two out of three of the modelled test-site areas, i.e. Fjällveden and Gideå, granite gneiss horizons within the migmatitic bedrock show a much higher hydraulic conductivity comparable in fact to the local fracture zones in the respective areas. To accommodate the model it was therefore necessary to assume an anisotropic hydraulic conductivity for the rockmass. However, in reality these distinct rock-types, which occur as discrete layers or dykes, behave more like the fracture zones.

As a further simplification of the geological data, two local fracture zones striking parallel to each other are sometimes considered as one hypothetical fracture unit, which is ascribed the total transmissivity of the two fracture zones. This means that the calculated groundwater flow adjacent to a borehole in such an situation will be erroneous. Furthermore, the local fracture zones are each considered to have the same hydraulic properties, irrespective of their orientation in the stress field. However, it should be pointed out that the limited amount of data available from such zones prevents a more thorough approach, and consequently the calculated groundwater flow and flow-directions can only be generalised.

The findings of this report show, however, that even allowing for the very simplified approach of such modelling, the results do illustrate the general groundwater-flow direction and relative velocity in the area as a whole. This is useful in achieving an indication as to the relative age of the groundwater sampled from the various levels. For example, whether the water sampled has circulated slowly from depth, or rapidly from higher, more oxidising and younger horizons. The lack of detail, however, means that the modelled information cannot be used to predetermine borehole locations or which horizons to be sampled prior to drilling. Furthermore, the absence of detail is also evident in the discrepancy between the predicted and measured piezometric head values.

6.5 Gas-lift Pumping

As described under Section 3 there are several sources of groundwater contamination introduced during the various borehole activities. Such contamination, e.g. drilling water, drilling debris, hydraulic testing, open-hole effects etc., are thought to be minimised by gas-lift pumping carried out just prior to sampling. The efficiency of such a technique will be dependent on the physical and hydraulic properties of the bedrock in general and of the fracture zone selected for sampling in particular.

A qualitative idea of the volumes of water involved during such an operation was obtained from the Klipperås test-site. Here, 6 m^3 of water was flushed to the surface during each of 4 pumpings, giving a total of 24 m^3 . The reason why such large amounts of water were flushed up is probably due to a high average hydraulic conductivity in the bedrock. Immediately after the flushing was stopped, the water level in the borehole was less than 10 m from the bedrock surface. During the first flushing period, the water level in two boreholes at a distance of 20 m and 170 m respectively from the flushed

borehole was measured. At 170 m the water level was only lowered a few centimetres, whereas at 20 m distance the water level had sunk about 0.8 m after 165 minutes.

Secure in the knowledge that large volumes of water can be removed, the next question is what percentage of the water originated during drilling (i.e. drilling water component)? Recent investigations (Ahlbom et al, 1985) at Finnsjön (approx. 150 km north of Stockholm) showed that on removal of around 62.5 m^3 water during gas-lift pumping, only 3 % comprised drilling water. The Finnsjön area is characterised by an overall higher average bedrock fracture frequency than the areas described in this report, and so most of the drilling water introduced during drilling has mixed with existing borehole water and disappeared into the bedrock. Loss of drilling water occurs especially within the upper 200-300 m of bedrock which, in common with the other test-site areas, is characterised by a highly conducting stress-released fracture system. In conclusion, gas-lift pumping is not an efficient method of removing the total drilling water volume introduced into the hole and adjacent bedrock. The more localised effect along individual fracture horizons is also minimal as illustrated in the water budget calculations presented for every sampled level.

In conclusion, because of the high fracture frequency and associated high hydraulic conductivity normally characterising the upper 200-300 m of bedrock (resulting in widespread mixing and dilution of groundwaters), gas-lift pumping is least effective for removing residual drilling water within this depth. To be more efficient at greater depths, it is recommended that the upper 200-300 m horizon should be packed off before the remaining borehole length is cleared of residual water and debris (see section 7). This method should prevent groundwaters originating from surface and near-surface sources (which often comprises considerable amounts of drilling water) from penetrating to depth. Furthermore, it should be a

more efficient method to remove a greater percentage of residual drilling water below this level.

Investigations at Finnsjön (Ahlbom et al, 1985) have also indicated qualitatively that gas-lift pumping only removes a small amount of drilling debris; for example, the amount of drilling debris produced from one of the boreholes (length 376 metres) was calculated to be about 1000 kg. As a result of flushing the hole twice, an estimated total of 5 kg was recovered. This is in excess of the small amounts that were extracted during the initial drilling period before all drilling water was lost to the bedrock (see section 3.7 for detailed discussion). Considerable amounts obviously still remain at the hole bottom and as coatings on the borehole surface and along intersecting fractures (see Section 3.7). Although the debris particles are thought to penetrate only short distances into the bedrock, and to be relatively unaffected by the natural hydraulic properties of the bedrock, colloidal particles, which can be of important chemical significance in radionuclide complexing and transportation, probably penetrate to considerable distances along with the natural groundwater flow.

To test for residual debris particles in the groundwaters, some monitoring of samples have been carried out during sample pumping at Fjällveden (Fj 2 at 468 m depth). Here samples have been systematically taken from a fracture zone of interest and analysed for particle content and bulk chemistry. It was found that the groundwater quickly became clear after commencement of pumping and a uniform particle content was soon achieved (0.01-0.10 mg/l) dominated by Al, Si and Ca; Fe is also sometimes present. This suggests an absence of drilling debris. These results may be interpreted as showing that fine debris particles introduced into and along certain hydraulic fracture zones are only partly removed during the initial surge of groundwater taken from the zone after pumping has begun. The system soon

stabilises and the particle content drops off. Furthermore, variation in pump velocity would probably reactivate particle removal during the initial stages of pumping. The presence of such particles, many of them comprising iron-oxides or coated with iron-oxides play an important role in absorption of ions such as uranium (e.g. Kamlunge test-site; Smellie, 1983a).

6.6 Location of Hydraulically-conducting Horizons

For the SKB programme, the normal hydrologic sequence is to carry out hydraulic testing along 25 m borehole sections (in some cases 10 m, 5 m and even 2 m sections have been measured). At a later stage which can vary from days to months, the 25 m section is relocated and sampled for groundwater. The question arises as to how certain one is of locating precisely the water conducting fracture (or fractures) that is to be sampled? It has been shown from several localities that the 2.7 m section sampled for groundwater, although falling within the 25 m section hydraulically tested, does not coincide with the actual conducting horizons; as the correlation between high fracture frequency and high hydraulic conductivity is normally poor, it is often a hit and miss situation. In the event of sampling from a non-conducting section of the borehole, a partial vacuum is established within the sampled section, resulting in borehole water being forced round the packer system.

During future investigations it is thus recommended that:

- 1) water-conducting fracture horizons are located initially using Tube Wave and/or borehole radar techniques prior to sampling and hydraulic measurements,
- 2) detailed hydraulic measurements (within approx. 2 m section lengths) are carried out along those borehole sections exhibiting a positive Tube Wave response; obtaining the pressure heads of the tested sections would facilitate the choice of the most suitable horizon for sampling,
- 3) the section length chosen for the detailed

hydraulic measurements should be shorter than the section length employed for sampling, and 4) the length of the section sampled should be flexible so as to accommodate the local geological features of the borehole (i.e. fracture frequency; bedrock composition etc).

To illustrate the first point, the Tube Wave technique, work carried out at Klipperås (K1 2) involved the location of suitable sampling horizons based solely on this method (Stenberg, 1984). During subsequent groundwater sampling other fracture zones mapped from the drillcore but not registered by the Tube Wave technique were also sealed off in the borehole and pumped. However, none of these were found to be conducting thus confirming that all the successfully sampled levels were those initially located by Tube Wave.

Regarding the second point, hydraulic testing which avoids the injection of water into the measured sections under investigation might initially be considered an obvious advantage. However, bearing in mind the more serious contaminating influence which results from the water-flushed core drilling, such a modified approach is considered unnecessary.

6.7 Influence of Bedrock Geochemistry on the Groundwater Chemistry

Little has been done in this area. The chemical characteristics of groundwaters have been observed to change significantly during their passage through the bedrock from near-surface conditions to depth. The chemical changes which occur depend largely on the leaching and retention properties of the waters as increasingly reducing conditions are encountered. The chemistry of the bedrock is therefore of major importance as an influence on groundwater composition and in turn on the formation of some of the low temperature fracture mineral phases. The contribution of the bedrock under

oxidising and reducing conditions from rocks of different physico-chemical characteristics therefore requires to be quantified. Of particular interest in this context is the existence of saline groundwaters; the salt content of very old groundwater is sometimes extremely high with no apparent upper limit for the salinity. The source of the salinity is sometimes debatable, with seawater, fluid inclusions and rock/water interactions all having been proposed as possible sources (Nordstrom, 1985). However, regardless of the ultimate origin, chemical modification of the waters have undoubtedly occurred due to contact with surrounding bedrock under relatively stagnant conditions over long periods of geological time.

From some of the areas described in this present report there are some indications that the bedrock has resulted in certain enrichments of individual elements. For example, in Fjällveden where waters have been sampled from greenstone horizons, i.e. there is a strong possibility that the groundwater has been in contact with the greenstone for some time/distance, there are detectable increases in iron. Large increases in sulphate were observed in groundwaters collected from an amphibolite bedrock mass in Kamlunge. Perhaps of even greater significance is the possibility that bedrock composition can influence the redox characteristics of the groundwater. For example, within a basic rock-type (e.g. greenstone, biotite gneiss, amphibolite etc) the increase in Fe^{2+} , in comparison with a more acid granite variety, is conducive to a more reducing environment for the groundwaters which are permeating through the rock via fractures and fissures.

From the evidence obtained from the test-site investigations, it may be more common than previously thought that many of the water-conducting horizons sampled are directly associated with dykes, schlieren or bands etc of rocks characterised by compositions distinct from the overall bedrock; these may also influence the groundwater compositions. Greater attention should be

given to such horizons in order to quantify their influence.

In addition to the highly conducting horizons which are normally sampled, it is also of interest to classify the total groundwater pattern by locating and sampling low-conducting zones or pockets in the bedrock (which may or may not be represented by saline waters) which up to now have been ignored by the preference for large volumes of water more convenient for sampling purposes. It is these isolated groundwaters, extractable from minor fissures and cracks, that are most likely to be directly influenced by the bedrock geochemistry.

6.8 The Relationship Between Fracture Mineralogy and Groundwater Characteristics

Low temperature fracture mineral phases can prove to be an invaluable complement to hydrochemical studies. As fracture filling mineral phases constitute the contact between groundwater and the bedrock, a detailed study of the mineralogy provides information about the chemical conditions prevailing at the groundwater/fracture interface. Using suitable data programs to evaluate reliable water analyses and the chemistry of the fracture minerals, equilibrium processes can be investigated in the groundwaters. This can indicate whether the water has had long residence times in contact with the fissure minerals (equilibrium conditions) or whether water movement has been too rapid for equilibrium to be established.

Furthermore, the bulk groundwater chemistry retains the signature of the dominating bedrock chemistry through which the waters have percolated. The possibility exists, therefore, given a data base of common rock-types and their related fracture mineral compositions, to predict the rock-type and its groundwater environment from the groundwater composition (D. Langmuir 1985, per. commun.).

Site specific investigations of low temperature fracture fillings (i.e. recent mineralisation) have been carried out at three of the test-sites: Finnsjön (not featured in this report), Gideå and Taavinunna (Tullborg and Larson, 1982, 1983; Larson and Tullborg, 1984). These workers found that by using frequency plots of calcite, iron-oxides and clay minerals (occurrence and composition) related to depth, useful information of the hydrological environment can be obtained. For example, calcite equilibrates easily with contact groundwaters and is a convenient mineral to identify, map and analyse. Thus calcite frequency and composition (stable isotopes of ^{18}O and ^{13}C) provide information on the groundwater physico-chemical environment and extent of the conducting pathways. Furthermore, it has also been observed that calcite frequency is related to regions of recharge and discharge. In an area of recharge the calcite near the ground surface will be dissolved by the downward percolating surface and near-surface waters, forming newly precipitated calcite at depth, a depth defined by the hydraulic conductivity, depth of overburden, fracture orientation, and bedrock type.

Calcite mobility plays an important part in the interpretation of radiocarbon data from the groundwaters; as pointed out earlier (section 2.2.3) such data should be treated with considerable caution. Repeated dissolution and precipitation of calcite will influence the ^{14}C content in the groundwater because the dissolution of calcite will contribute radiometric "dead" HCO_3^- to the groundwater and precipitation will result in an enrichment of ^{14}C in the newly formed calcite. These combined effects will serve to decrease the ^{14}C in the groundwater which in turn will produce high radiocarbon ages. However, the dating of calcite and the groundwaters can result in useful data in the interpretation of groundwater circulation in the bedrock.

Another very useful approach is to carry out uranium decay series measurements (^{238}U - ^{234}U - ^{230}Th) on carefully selected fracture zone mineral phases, together with the contact groundwaters. Isotopic characterisation of the fracture zones can reveal the redox nature of contact groundwater, i.e. whether the fracture section (usually selected from a drillcore) represents a redox environment of uranium leaching or precipitation. Work of this nature has been carried at Kamlunge (Smellie, 1984; 1985). In this study samples were investigated from the intact bedrock and compared with large-scale water-conducting fractures which extended from the bedrock surface to depths of at least 600 m. The results showed that: 1) the investigated bedrock environment (100-600 m) was generally reducing, however, 2) there was some evidence to indicate that rock/water interaction had removed total uranium resulting from the presence of less reducing groundwaters within the large-scale fracture/crush zones which intersect the bedrock surface. Such a marginally oxidising groundwater environment was also suggested from the groundwater chemistry described under Section 5.4.

6.9 Influence of Pumping on the Physico-chemical Properties of Groundwaters

Resulting from investigations at the Kamlunge test-site (Smellie, 1983a), whereupon systematically collected groundwater samples were analysed for dissolved uranium and its daughter isotopes ^{238}U and ^{234}U , it was noted that an increase in uranium content and the $^{234}\text{U}/^{238}\text{U}$ activity ratio occurred in the groundwater following an unscheduled pump stop of some 14 hours. Monitoring of Eh during this period indicated a sympathetic increase. These findings resulted in controlled experiments being carried out at the Kamlunge and Taavinunnen test-sites. The results are reported in full by Smellie (1983b, 1983c) and summarised in Appendix 3 of this report.

The most important conclusion arising from these studies is that in certain geological environments an excessive groundwater pump flow-rate during sampling can result in the tapping of groundwaters from shallower or deeper sources in the bedrock, depending on the geometry of the hydraulic fracture mosaic, causing varying degrees of contamination and mixing. As an excessive pump flow-rate at one level may be adequate for another, it is important, prior to sampling, to evaluate an optimum flow-rate by continuous monitoring of, for example, Eh and oxygen content, over a suitable time period. When the character of the groundwater has stabilised to what might be expected for the horizon under investigation, and there is adequate groundwater for sampling purposes, sampling can proceed.

6.10 Drilling Water Properties

For the majority of boreholes described from the different test-sites, drilling has been carried out using flushing water pumped from shallow levels in the bedrock; most would be classified as shallow groundwater in type and marginally reducing in character. Surface waters have been used in some instances, e.g. Taavinunannen, where surface lake water was used.

Shallow groundwaters have been employed in an attempt to reduce the contaminating effects during drilling. However, whilst being an important step in the right direction, the problem of contamination still remains. For example, using shallow groundwater as drilling fluid is favourable for a shallow groundwater environment. However, at deeper levels such drilling water will introduce an unwanted younger, shallower component to the surrounding bedrock. The ideal, but mostly impracticable solution, would be to drill each succeeding depth of borehole with drilling water obtained from the corresponding general depth. Shallow groundwater would therefore appear to be the best compromise.

One of the main problems encountered using a shallow groundwater source is that when the groundwater is pumped to the surface, it is stored in tanks and can remain there for varying periods before use depending on the nature of the bedrock properties, i.e. more drilling water will be required during high water loss to a substantially fractured bedrock. Pumping and storing will lead to the water becoming oxidised. Drilling with such oxidised water at depth can serve to oxidise Fe^{2+} to Fe^{3+} resulting in Fe^{3+} precipitation along the fine fractures, which can lead to the preferential absorption of certain species such as uranium. This problem can be tackled by storing the drilling water in tanks under pressure and under an inert atmosphere (e.g. N_2).

In the event of the drilling water being recycled during drilling, samples should be systematically collected and analysed. Thus, by knowing the composition of the initial drilling water, and later knowing the composition of the recycled water, an idea of which elements are being removed either chemically or mechanically, can be ascertained. For example, it is suspected that easily dissolved elements (e.g. uranium especially if the drilling water is slightly oxidising) can be removed from fracture zones which are later investigated in detail. It is thus important to know whether these elements have been removed by solution under high pressure drilling, or by naturally circulating groundwater in the fracture zone prior to drilling.

6.11 Bedrock Sampling Locations - Bedrock vs Fracture Zones

Continual reference has been made throughout this report to representative or contaminated groundwater samples. Representative samples are those which show no evidence of mixing with other water sources, whether from drilling water, younger, surface to near-surface water, or other

deeper groundwaters. However, because crystalline rock permeability is mostly a function of fractures which are hydraulically connected, groundwater sampling locations naturally occur when these fractures are intercepted by the borehole. Because of the volumes of water required (the removal of contaminating waters prior to sampling, and subsequently waters for sampling and analysis), only the most conductive zones have been chosen, i.e. in some cases the local fracture zones which normally extend to the bedrock surface. Experience has shown that groundwaters sampled from such zones are usually a product of groundwater mixing from different sources, and hence often representative for the various groundwater environments breached by these deeply penetrating fractures. In other words, the groundwaters resulting from highly conductive fracture horizons are representative for the fracture zones but not necessarily for the sampling depth because, depending on the orientation and hydraulic properties of the fracture zone, the groundwater contained therein may have primarily originated at depths considerably higher and/or lower than the sampled point.

Groundwaters which are more precisely depth-related should be obtained from fractured horizons of a more local extent in the bedrock. Unfortunately such zones are usually of limited conductivity which requires long sampling periods at an optimum pump flow-rate. Longer sampling sections of the borehole would facilitate such sampling.

In summary, of the few groundwater samples discussed in this report which have been classified as representative, the majority have been sampled from fracture horizons which are reasonably conducting and therefore probably represent groundwater accumulated over a considerable thickness of bedrock. To ensure that the groundwater represents a bedrock source, rather than a borehole source (by short-circuiting processes), only fracture zones of high intersection angles with the borehole axis

should be selected. Low angle fracture intersections might encourage short-circuiting with the borehole. Very little information is available from the bedrock at specific depths; this is necessary as the groundwater chemistry of the bedrock samples should be more typical of rock/water interaction processes etc. Longer borehole sections should be sampled systematically to really classify the groundwater chemistry.

6.12 Borehole Sealing

Following borehole drilling, and then later subsequent to groundwater sampling, the borehole is normally left open for long periods of time. During such periods open-hole effects become important within the borehole which acts as a short-circuiting pathway. This can result in the mixing of groundwaters from different depths and of different character.

In an attempt to reduce this risk, plugging of the borehole is recommended whenever the hole is to be left for any considerable time. The water-conducting horizons to be isolated will be those characterised by a sufficiently high hydraulic conductivity. As a suggestion, based on the test-sites described in this report, a limiting value of $1.1 \cdot 10^{-9}$ m/s could be considered as being appropriate. In addition, some section of great head deviation should also be isolated. The number of plugs required will depend on whether hydrological or water chemical properties are being investigated. As pointed out on many occasions, the upper 200-300 m of bedrock in Sweden is normally highly fractured and conductive. From a hydrochemical point of view the borehole should be plugged, as standard procedure, at the lower limit of this zone. This would effectively avoid the incursion to depth of surface to near-surface waters which form a major contaminating component to many of the sampled groundwaters described in this report. At deeper levels each conducting zone

could be plugged with independent, self-functioning packers which can be installed and removed when required for hydraulic, hydrochemical and geophysical measurements.

From hydrological considerations, even those conducting horizons within the upper bedrock environs should be plugged as a better impression of the overall groundwater flow conditions can then be ascertained.

However, depending on special circumstances such as well-defined conductive horizons in an otherwise non-conductive bedrock, the natural bedrock hydraulic flow pattern may not be markedly influenced by the borehole. For example, groundwater sampling in borehole K1 1 (Klipperås) was carried out immediately after drilling in December 1983. This should have minimised any open-hole effect due to conductive horizons characterised by different piezometric pressures. As reported above (Section 5.6) a representative groundwater was obtained. To test for open-hole effects over a much longer time-scale, the same borehole was re-sampled in June 1985. The results show that the groundwater composition was relatively unchanged. In this case, therefore, whereupon the only conducting horizon was characterised by a low hydraulic conductivity and small positive piezometric head, the open-hole effect has had little impact.

7. RECOMMENDATIONS FOR IMPROVING GROUNDWATER SAMPLING QUALITY

Based on the findings of this report, there is much room left for the improvement of groundwater sampling methods. These improvements can be subdivided into the cored borehole system already employed, and a new untried system employing percussion or booster hole techniques. Several of the improvements recommended have to some extent been already implemented.

7.1 Cored borehole system

The following procedure is recommended:

- plugging the drilling water supply hole (percussion borehole down to 100-150 m) with rubber packers to ensure that the groundwater used is from a particular horizon (preferably shallow to intermediate groundwater in type) and thereby uncontaminated by higher-level oxidising waters.
- when pumped to the surface the drilling water should be stored under pressure and in an inert atmosphere (e.g. N_2). Otherwise there is the risk that the waters become oxidised before being flushed down the hole during drilling.
- casing (temporary) of the uppermost 100-250 m of the borehole during drilling. This will diminish the loss of drilling water and rock debris into the bedrock and thus increase considerably the volume of rock debris eventually removed from the borehole by gas-lift pumping.
- systematic sampling of the initial and recycled drilling water (including the volume necessary for mass balance calculations) to evaluate the drilling water impact on the bedrock geochemistry. This would be

facilitated by casing the uppermost 100-250 m during drilling.

- on completion of the drilling and removal of the temporary casing, the hole should be plugged at the lower limit of the casing. This will: a) increase the clearing efficiency at depth during gas-lift pumping, and b) ultimately reduce a major source of near-surface contamination prior to groundwater sampling.

Presented with a plugged and cleared borehole, the following procedure is recommended for the selection and sampling of suitably conducting horizons:

- location and sampling of the major water-conducting horizons identified by Tube Wave and/or borehole radar techniques.
- detailed geological examination of the core combined with hydraulic testing to further locate potential zones for groundwater sampling. It is recommended that the packer spacing for the hydraulic injection tests should be smaller than that employed during sampling. This will ensure that the conducting horizon located by the hydraulic testing can be fully contained by the wider packing section used for sampling.
- the packer spacing for sampling should be flexible depending on the hydrogeological and geological properties of the fractured horizon to be sampled and the adjacent bedrock. For example, the borehole section to be sampled should: a) contain no fractures near or overlapping with the packers, b) enclose completely the horizon to be sampled, and c) not be located in the near-vicinity of large-scale parallel or sub-parallel fracture zones which could easily be interconnected via a more minor fracture system with the section to be sampled.

- to minimise sampling of groundwater of mixed origin, sections of moderate hydraulic conductivity, excess piezometric pressure, and a suitable flow-rate, are preferable.
- use of pressure regulated groundwater sampling flow-rate by continuous pressure registration to avoid leakage of borehole water into the sampling section. This approach, combined with continuous monitoring of Eh, pH, O₂ etc, can also be used to establish an optimum groundwater pump flow-rate for the horizon of interest, in order to ensure as representative a sample as possible. This may require up to one week in order to ensure stabilisation of the Eh electrodes.
- systematic sampling of the bedrock sections devoid of significant fracturing to evaluate the local influence of the bedrock chemistry on the composition of the groundwater.
- packer lengths of at least one metre should be employed; in very fractured borehole sections, a series of packers are recommended to minimise short-circuiting from the borehole via conducting fracture networks to the section being sampled.

7.2 Percussion (Booster) Hole Drilling

In an attempt to overcome many of the problems of groundwater sampling and interpretation revealed from this study, a special percussion hole for hydrochemical purposes has been proposed. Such an approach offers several advantages, two of which are:

- the absence of flushing water during drilling avoids a major source of contamination which otherwise would occur.

- air flushing during percussion drilling should be sufficient to remove the fine rock debris from around the drill head. Minimum penetration of debris along conducting horizons (whether characterised by a positive or negative piezometric head) would be expected.

Ideally, hydrochemical investigations should be conducted before the complete programme of bedrock drilling and hydraulic testing is carried out at the test-site. It is thus proposed that investigations should involve at an early stage the drilling of a percussion borehole for hydrochemical purposes central to the delineated site. It should be vertical and extend down to at least 600-800 metres.

The envisaged hydrochemical programme would entail:

- sampling carried out during drilling, i.e. when a significant water-conducting horizon is breached, the drilling head can be removed, a single packer installed just above the conducting zone, and groundwater collected from between the hole bottom and the packer.
- if no water-conducting horizons are encountered, sampling should be attempted after every 100 m of drilling. The packer would be systematically raised in the borehole from close to the hole bottom until groundwater could be collected.
- after drilling is completed, the second phase of sampling can be initiated. The horizons chosen will be selected on the basis of tube wave and borehole radar measurements. Horizons already sampled can be supplemented to check for any compositional changes.
- subsequent to this second sampling phase the hydraulic tests should be conducted which would include detailed measurements of the sampled horizons.

In a recent study of the Finnsjön area (Ahlbom et al, 1985) a crude simulation of groundwater sampling was carried out during the drilling of a shallow percussion hole. Sampling entailed collecting water as soon as a water-conducting zone was encountered. In this instance the technique has proved to be very promising.

One of the potential disadvantages of percussion drilling is the resulting unevenness of the borehole wall; this will depend on the mechanical action of the drilling and also on the physical properties of the bedrock. Packing-off the hole for groundwater sampling may therefore be suspect in terms of leakage around the packer systems.

8. ACKNOWLEDGEMENTS

The efforts of those many persons, too many to be listed here, who have produced through the years the considerable volume of information compiled in this report, are acknowledged. Those who have critically commented on various aspects of the work include Jordi Bruno (KTH), Erik Gustafsson (SGAB), Kent Hansson (SGAB) and Eva-Lena Tullborg (SGAB). Of special mention is Fred Karlsson (SKB) who was instrumental in initiating the work and for his continuing support and constructive suggestions throughout.

9. REFERENCES

- Åberg, G., 1978. Precambrian geochronology of south-eastern Sweden. Geol. Fören. Stockh. Förh., 100: 125-154.
- Ahlbom, K., Larson, S-Å. and Olkiewicz, A., 1982. Taavinummanen gabbro: results from surface geological and drillcore investigations (In Swedish). SKBF/KBS Status Report AR 82-55. Stockholm.
- Ahlbom, K., Henkel, H., Scherman, S. and Tirén, S., 1980. Reconnaissance studies for suitable test-site areas in central and northern Norrland during the period 1979-80. (In Swedish). Rapport PRAV 4.22. Stockholm.
- Ahlbom, K., Carlsson, L. and Olsson, O., 1983a. Final disposal of spent nuclear fuel -geological, hydrological and geophysical methods for site characterization. SKBF/KBS Technical Report TR 83-43. Stockholm.
- Ahlbom, K., Carlsson, L., Carlsten, L-E., Duran, O., Larsson, N-Å. and Olsson, O., 1983b. Evaluation of the geological, geophysical and hydrogeological conditions at Fjällveden. SKBF/KBS Technical Report TR 83-52. Stockholm.
- Ahlbom, K., Albino, B., Carlsson, L., Nilsson, G., Olsson, O., Stenberg, L. and Timje, H., 1983c. Evaluation of the geological, geophysical and hydrogeological conditions at Gideå. SKBF/KBS Technical Report TR 83-53. Stockholm.
- Ahlbom, K., Carlsson, L., Gentschein, B., Jämtlid, A., Olsson, O. and Tirén, S., 1983d. Evaluation of the geological, geophysical and hydrogeological conditions at Svartboberget. SKBF/KBS Technical Report TR 83-55. Stockholm.

Ahlbom, K., Albino, B., Carlsson, L., Danielson, J., Nilsson, G., Olsson, O., Sehlstedt, S., Stejskal, V. and Stenberg, L., 1983e. Evaluation of the geological, geophysical and hydrogeological conditions at Kamlunge. SKBF/KBS Technical Report TR 83-54. Stockholm.

Ahlbom, K., Andersson, P., Carlsson, L., Ekman, L., Smellie, J.A.T. and Tullberg, E-L., 1985. Results from Phase 1 of the fracture project at Brändan, Finnsjön. Swedish Geological Company (SGAB) Internal Report IRAP 85222. Uppsala.

Albino, B., Nilsson, G. and Stenberg, L., 1982. Geological and geophysical investigations at the Gideå test-site. (In Swedish). SKBF/KBS Status Report AR 83-19. Stockholm.

Albino, B., Nilsson, G., Stejskal, V., Sehlstedt, S. and Stenberg, L., 1983. Geological and geophysical investigations at the Kamlunge test-site. (In Swedish). SGAB Internal Report IRAP 83022. Luleå.

Albino, B., 1984. Geophysical investigations from borehole Ta 1: Taavinunnanen test-site. (In Swedish). SGAB Internal Report IRAP 84014. Luleå.

Allard, B., 1983. Actinide solution equilibria and solubilities in geological systems. SKB/KBS Technical Report TR 83-35. Stockholm.

Almön, K-E., Andersson, O., Hansson, K., Johansson, B-E., Nilsson, G., Wikberg, P. and Anagen, H., 1983. Final disposal of spent nuclear fuel - equipment for site characterisation. SKBF/KBS Technical Report TR 83-44. Stockholm.

Ambros, M., 1980. Geological description of map sheets Lannavaara NW, NE, SW, SE and from Karesuando SW and SE. (In Swedish). Swedish Geological Survey (SGU). Af 25-30. Uppsala.

- Andersson, J-E. and Carlsson, L., 1980. Hydraulic tests. Part I: Influence of wellbore storage and skin by different transient tests. (In Swedish). SKBF/KBS Status Report AR 80-38. Stockholm.
- Andersson, J-E. and Carlsson, L., 1981. Hydraulic tests. Part II: Pulse response tests. (In Swedish). SKBF/KBS Status Report AR 82-35. Stockholm.
- Andersson, P. and Klockars, C-E., 1984. Hydrogeological investigations and tracer tests in a well-defined rock matrix in Stripa mine. (In Swedish). Status Report. SKBF/KBS AR 84-17. Stockholm.
- Andrews, J.N., Giles, I.S., Kay, R.L.F., Lee, D.J., Osmond, J.K., Cowart, J.B., Fritz, P., Barker, J.F. and Gale, J., 1982. Radioelements, radiogenic helium and age relationships for groundwaters from the granites at Stripa, Sweden. *Geochim. Cosmochim. Acta.* 46. 1533-1543.
- Andrews, J.N. and Kay, L.F., 1982. $^{234}\text{U}/^{238}\text{U}$ activity ratios of dissolved uranium in groundwater from a Jurassic aquifer in England. *Earth Planet. Sci. Lett.*, 57. 139-151.
- Andrews, J.N. and Kay, R.L.F., 1983. The U-contents and $^{234}\text{U}/^{238}\text{U}$ activity ratios of dissolved uranium in groundwaters from some Triassic sandstones in England.
- Ask, K. and Carlsson, L., 1984. Groundwater influence by boreholes and borehole activities in crystalline rocks - preliminary studies. SKBF/KBS Status Report AR 84-27. Stockholm.
- Bianchi, L. and Snow, D.T., 1969. Permeability of crystalline rocks interpreted from measured orientations and apertures of fractures: Jodhpur, Rajasthan, Arid Zone Research Assoc. of India. *Annals of Arid Zone*, 8. 231-245.

- Bruno, J., Forsythe, R. and Werme, L., 1984. "Spent UO_2 -fuel dissolution tentative modelling of experimental apparent solubilities". In: Scientific Basis for Nuclear Waste Management VIII (eds. C.M. Jantzen, J.A. Stone, and R.C. Ewing). Boston.
- Carlsson, L. and Carlstedt, A., 1977. Estimation of transmissivity and permeability in Swedish bedrock. *Nordic Hydrology*, 8. 103-116.
- Carlsson, L. and Gustafsson, G., 1984. Hydrogeological investigate methods - Test-pumping. (In Swedish). BFR Report 41:1984. Stockholm.
- Carlsson, L., Winberg, A. and Grundfelt, B., 1983. Model calculation of the groundwater flow at Finnsjön, Fjällveden, Gideå and Kamlunga. SKBF/KBS Technical Report TR 83-45. Stockholm.
- Carlsten, S., Duran, O. and Kautsky, F., 1983. Geological and geophysical investigations at the Fjällveden test-site. (In Swedish). SKBF/KBS Status Report AR 83-13. Stockholm.
- Cowart, J.B., 1980. The relationship of uranium isotopes to oxidation/reduction in the Edwards Carbonate aquifer of Texas. *Earth Planet. Sci. Letters*. 48.
- Craig, H., 1961. Isotopic variations in meteoric waters. *Science* 133. 1702-1703.
- Eriksson, E., 1962. Radioactivity in hydrology. In: Nuclear radiation in geophysics. (Eds. H. Israel and A. Kreds), Springer-Verlag, New York, N.Y.
- Eriksson, B., 1980. Sweden's Water Balance. Annual Mean Values (1931-60) of Precipitation, Evaporation and Run-off. (In Swedish). SMHI Report RMK 18. Norrköping.

- Eriksson, B. and Hallgren, U., 1975. Geological description of map sheets Vittangi NW, NE, SW and SE. (In Swedish). Swedish Geological Survey (SGU). Af 13-16. Stockholm.
- Fleischer, R.L. and Raabe, O.G., 1978. Recoiling alpha-emitting nuclei. Mechanisms for uranium-series disequilibrium. *Geochim. Cosmochim. Acta*, 42. 973-978.
- Fontes, I.C., 1980. Environmental isotopes in groundwater hydrology. In: Handbook of environmental isotope geochemistry. (Ed. P. Fritz and I.C. Fontes). Vol 1 (The terrestrial environment, A). Elsevier. Amsterdam.
- Fontes, I.C., 1981. Palaeowaters. In: Stable Isotope Hydrology. Deuterium and oxygen -18 in the water cycle. Technical Reports Series nr. 210. IAEA, 273-302. Vienna.
- Gale, J.E., 1982. Assessing the permeability characteristics of fractured rock. *Geol. Soc. of America. Spec. Paper* 189.
- Gentzschein, B., 1983a. Hydrogeological investigations at the Svartboberget test-site. (In Swedish). SKBF/KBS Status Report AR 83-23. Stockholm.
- Gentzschein, B., 1983b. Hydrogeological investigations at the Taavinnanen test-site. (In Swedish). SKBF/KBS Status Report AR 84-25. Stockholm.
- Gentzschein, B., Larson, S-Å. and Tullborg, E-L., 1985. The Taavinnanen gabbro massif. SKB Technical Report TR 85-02. Stockholm.
- Geyh, M.A., 1972. On the determination of the dilution factor of groundwater. *Proc. 8th Int. Radiocarbon Dating, New Zealand*. 369-380.
- Giblin, A.M., Batts, B.D. and Swaine, D.J., 1981. Laboratory simulation studies of uranium mobility in natural waters. *Geochim. Cosmochim. Acta*, 45, 699-709.

- Gulson, B.L., 1972. The Precambrian geochronology of granitic rocks from northern Sweden. Geol. Fören. Stockh. Förh. 94, 229-244.
- Hallgren, U., 1979. Geological description of map sheets Soppero NW, NE, SW, SE. (In Swedish). Swedish Geological Survey (SGU). Af 31-34. Uppsala.
- Henkel, H., 1981. A large gabbro intrusion in Northern Sweden. (In Swedish). Swedish Geological Survey (SGU), Geophysics Division Internal Report 8110, 44-51. Uppsala.
- Holst, N.O., 1876. Geological description of map sheet Lessebo. (In Swedish). Swedish Geological Survey (SGU). Ab 4. Stockholm.
- Holst, N.O., 1893. Geological description of map sheet Lenhofda. (In Swedish). Swedish Geological Survey (SGU). Ab 15. Stockholm.
- Hostetler, P.B. and Garrels, R.M., 1962. Transportation and precipitation of uranium and vanadium at low temperatures, with special reference to sandstone type uranium deposits, Econ. Geol. 57, 137-167.
- Kaufman, M.I., Rydell, H.S. and Osmond, J.K., 1969. ²³⁴U/²³⁸U disequilibrium as an aid to hydrologic studies of the Floridan Aquifer. Jour. Hydrol. 9, 374-386.
- KBS-3, 1983. Final storage of spent nuclear fuel. SKBF/KBS Stockholm.
- Kigoshi, K., 1971. Alpha recoil ²³⁴Th: dissolution into water and the ²³⁴U/²³⁸U disequilibrium in nature. Science, 173, 47-48.
- Knutsson, G. and Fagerlind, T., 1977. Groundwater supplies in Sweden. (In Swedish). Swedish Geological Survey (SGU) Reports and Notices Nr. 9. Stockholm.

- Koide, M. and Goldberg, E.D., 1965. Uranium-234/uranium-238 ratios in seawater. In: Progress in Oceanography (Ed. M. Sears), 3, 173-177 (Pergamon, Oxford).
- Kronfeld, J., 1974. Uranium deposition and ^{234}Th alpha recoil: an explanation for extreme $^{234}\text{U}/^{238}\text{U}$ fractionation within the Trinity aquifer. Earth Planet. Sci. Lett., 27, 327-330.
- Kronfeld, J., Gradsztajn, E., Muller H.W., Radin, J., Yaniv, A. and Zach, R., 1975. Excess ^{234}U : an aging effect in confined waters. Earth Planet. Sci. Lett., 27, 342-345.
- Langmuir, D., 1978. Uranium solution-mineral equilibria at low temperatures with applications to sedimentary ore deposits. Geochim. Cosmochim. Acta, 42, 547-569.
- Langmuir, D. and Herman, J.S., 1980. The mobility of thorium in natural waters at low temperatures. Geochim. Cosmochim. Acta, 44, 1753-1766.
- Larsson, N-Å., 1983. Hydrogeological investigations at the Fjällveden test-site. (In Swedish). SKBF/KBS Status Report AR 83-12. Stockholm.
- Larson, S-Å. and Tullborg, E-L., 1984. Fracture fillings in the gabbro massif of Taavinnanan, northern Sweden. SKBF/KBS Technical Report TR 84-08. Stockholm.
- Larson, S-Å., Olkiewicz, A., Ahlbom, K. and Alinder, C., 1984. A tentative model of the Taavinnanan gabbro - results from a core-drilling. Geol. Fören. Stockh. Förh. 106, 119-126.
- Laurent, S., 1982. Analysis of groundwater from deep boreholes in Kråkenåla, Sternö and Finnsjön. SKBF/KBS Technical Report TR 82-23. Stockholm.

- Laurent, S., 1983a. Analysis of groundwater from deep boreholes in Fjällveden. SKBF/KBS Technical Report TR 83-19. Stockholm.
- Laurent, S., 1983b. Analysis of groundwater from deep boreholes in Gideå. SKBF/KBS Technical Report TR 83-17. Stockholm.
- Laurent, S., 1983c. Analysis of groundwater from deep boreholes in Svartboberget. SKBF/KBS Technical Report TR 83-41. Stockholm.
- Laurent, S., 1983d. Analysis of groundwater from deep boreholes in Kamlinge. SKBF/KBS Technical Report TR 83-70. Stockholm.
- Laurent, S., 1983e. Analysis of groundwater from deep boreholes in Taavinunnanen. SKBF/KBS Technical Report TR 84-36. Stockholm.
- Libby, W.F., 1965. Radiocarbon dating. University of Chicago Press, Chicago, Ill.
- Long, J.C.S., Remer, J.S., Wilson, C.R. and Witherspoon, P.A., 1982. Porous media equivalent for networks of discontinuous fractures. Water Resources Research, 18, 3.
- Lundegårdh, P.H., 1967. Bedrock geology of Gävleborgs County. (In Swedish). Swedish Geological Survey (SGU), Series Ba 22. Stockholm.
- Lundström, I., 1974. Geological description of the map sheet Nyköping SW. Swedish Geological Survey (SGU) Af 109. Stockholm.
- Lundström, I., 1976. Geological description of the map sheet Nyköping SE. Swedish Geological Survey (SGU) Af 114. Stockholm.

- Lundström, L. and Stille, H., 1978. Large-scale permeability test of the granite in the Stripa mine and thermal conductivity test. KBS/LBL Technical Project, Report 2. Stockholm.
- Lundquist, T., 1963. Description of the soil cover within Gävleborgs County. (In Swedish). Swedish Geological Survey (SGU) Ca 42. Stockholm.
- Lundquist, T., 1968. Precambrian geology of the Los-Hamra region, central Sweden. Swedish Geological Survey (SGU) Ba 23. Stockholm.
- Lundquist, T., 1979. The Precambrian of Sweden. Swedish Geological Survey (SGU) C 768. Stockholm.
- Lundquist, T., 1980. The Precambrian stratigraphy of Västernorrland County, Geol. Fören. Stockh. Förh. 102, 187-188.
- Mook, W.G., 1980. Carbon-14 in hydrogeological studies. In: Handbook of environmental isotope geochemistry. (Ed. P. Fritz and I.C. Fontes). Vol 1. (The Terrestrial Environment, A). Elsevier. Amsterdam.
- Nir, A., Krugger, S.I., Lingenfelder, R.E. and Flamm, E.-J., 1966. Natural tritium. Rev. Geophys., 4, 441-456.
- Nordström, D.K., 1985. Hydrological and hydrochemical investigations in boreholes - final report of the Phase 1 geochemical investigations of the Stripa groundwaters. Stripa Project Technical Report 85-06. Stockholm.
- Norton, D. and Knapp, R., 1977. Transport phenomena in hydrothermal systems: The nature of porosity. Amer. Jour. Sci. 277, 913-936.

- NUREG, 1983. Draft site characterization analysis of the site characterization report for the BWIP, Hanford, Washington Site. Appendix I. U.S. Nuclear Regulatory Commission (NUREG-0960, Vol 1).
- Ödman, O., 1957. Geological description of the Precambrian in Norrbotten County. (In Swedish). Swedish Geological Survey (SGU) Ca 41. Stockholm.
- Olkiewicz, A., Magnusson, K-Å., Tirén, S.A. and Gentzschein, B., 1984. Geological, geophysical and hydrogeological investigations of the Klipperås area (Map Sheet 4F NE Småland). (In Swedish). Swedish Geological Company (SGAB) Internal Report. Uppsala.
- Osmond, J.K., Kaufman, H.I. and Cowart, J.B., 1974. Mixing volume calculations, sources and aging trends of Floridan aquifer water by uranium isotopic methods. *Geochim. Cosmochim. Acta.* 38, 1038-1100.
- Osmond, J.K. and Cowart, J.B., 1976. The theory and uses of natural uranium isotopic variations in hydrology. *Atom. Energy Rev.* 14, 621-679.
- Osmond, J.K. and Cowart, J.B., 1982. Ground water. In: M. Ivanovich and R. S. Harmon (Editors), *Uranium Series Disequilibrium: Applications to Environmental Problems*. Oxford University Press, Oxford, pp. 202-245.
- Perttunen, V., 1980. Stratigraphy of the Peräpohja schist in the eastern part of the Baltic Shield. *Proceedings of a Finish-Soviet Symposium held in Finland.* 139-145. (21-26 August, 1979).
- Rai, D., Ryan, J.L. and McCulloch, M., 1984. Neptunium (IV) hydrous oxide solubility under reducing and carbonate conditions. *Pacific Northwest Laboratory Report PNL-SA-12096*.

- Rosholt, J.N., 1959. Natural radioactive disequilibrium of the uranium series. U.S. Geol. Surv., Bull., 1084-A.
- Rosholt, J.N., Shields, W.R. and Garner, E.L., 1963. Isotope fractionation of uranium in sandstone. Science. 139, 224-226.
- Rosholt, J.N., Doe, B.R. and Tatsumoto, M., 1966. Evolution of the isotopic composition of uranium and thorium in soil profiles. Geol. Soc. Am. Bull., 77, 987-1004.
- Rosholt, J.N., 1983. Isotopic composition of uranium and thorium in crystalline rocks. J. Geophys. Res., 88 (8-9), 7315-7330.
- Runeson, K., Tångfors, H. and Wikberg, H-E., 1979. GEOFEM-G. Computer program for ground water seepage including aquifer analysis. Publ. 79:6, Dept of Structural Mechanics, Chalmers University of Technology, Göteborg.
- Ryan, J.L. and Rai, D., 1983. The solubility of uranium (IV) hydrous oxide in sodium hydroxide solutions under reducing conditions. Polyhedron 2, 947.
- Ryan, J.L. and Rai, D., 1984. Thorium (IV) hydrous oxide solubility. Pacific Northwest Laboratory Report (In preparation).
- Smellie, J.A.T., 1983a. Progress report of uranium-series disequilibrium studies on surface- and ground waters from the Kamlunge area, and the ground waters from the Gideå, Fjällveden and Svartboberget areas. Swedish Geological Company (SGAB) Internal Report. Luleå.
- Smellie, J.A.T., 1983b. Groundwater pump flow-rate and its effect on some physico-chemical parameters - a controlled experiment carried out at Kamlunge. Swedish Geological Company (SGAB) Internal Report IRAP 4055. Luleå.

- Smellie, J.A.T., 1983c. Groundwater pump flow-rate and its effect on some physico-chemical parameters - a controlled experiment carried out at Taavimunnanen, Norrbotten. SKBF/KBS Status Report AR 83-45. Stockholm.
- Smellie, J.A.T., 1984. Uranium-series disequilibrium studies of drillcore Km 3 from the Kamlunge test-site, northern Sweden. SKBF/KBS Technical Report TR 84-06. Stockholm.
- Smellie, J.A.T., 1985. Uranium-series disequilibrium studies of drillcore Km 3 from the Kamlunge test-site, northern Sweden. Mineral. Mag. 49, 271-279.
- Stålhös, G., 1975. Geological description of map sheet Nyköping NE. Swedish Geological Survey (SGU) Af 115. Stockholm.
- Stenberg, L., 1984. Tube Wave measurements in borehole Kl 2, Klipperås. (In Swedish). Swedish Geological Company (SGAB). Internal Report IRAP 84105. Luleå.
- Stokes, J., 1980. On the description of the properties of fractured rock using the concept of a porous medium. SKBF/KBS Technical Report TR 80-05. Stockholm.
- Swedish Geological Survey (SGU): Geological Map of Sweden. Ba 16. Stockholm.
- Thurber, D.L., 1967. Anomalous $^{234}\text{U}/^{238}\text{U}$ in nature. J. Geophys. Res., 67, 4518-4520.
- Tirén, S.-A., Eriksson, L. and Henkel, H., 1981. A study of the geology, geophysics and tectonics in the Voxna area, and the Svartöberget test-site. (In Swedish). PRAY Report 4. Stockholm.
- Tirén, S.-A., 1982. Compilation of technical data from drilled cored holes in the Svartöberget area. (In Swedish). Swedish Geological Survey (SGU), Basement Geology Division. Internal Report. Uppsala.

- Törnebohm, A.E., 1882. Description of map sheet Nr. 8 comprising part of the geology of Bergslagen area in Central Sweden. (In Swedish). Jernkontoret Stockholm.
- Tullborg, E-L. and Larson, S-Å., 1982. Fissure fillings from Finnsjön and Studsvik, Sweden. Identification, chemistry and dating. SKBF/KBS Technical Report TR 82-20. Stockholm.
- Tullborg, E-L. and Larson, S-Å., 1983. Fissure fillings from Gideå, Central Sweden. SKBF/KBS Technical Report TR 83-74. Stockholm.
- Tullborg, E-L., 1985. Effects on fissure calcite by recharge water - some problems related to ¹⁴C-dating of groundwater. In: Scientific Basis for Nuclear Waste Management IX. Stockholm. (In press).
- Tullborg, E-L., and Winberg, A., 1985. Comparison between ¹⁸O-values in deep groundwaters and precipitation. Swedish Geological Company (SGAB) Internal Report IRAP 85407. Göteborg.
- Villas, R.N., 1975. Fracture analysis, hydrodynamic properties and mineral abundance in altered igneous wall-rocks of the Mayflower mine, Park City district, Utah. Ph.D. dissert., Univ. Utah, Salt Lake City. 253 p.
- Melin, E., 1970. Svecofennian orogenic zones in northern Sweden - a preliminary discussion. Geol. Fören. Stockh. Förh. 92, 433-451.
- Melin, E., Christiansson, K. and Nilsson, Ö., 1970. Rb-Sr age dating of intrusive rocks of the Haparanda suite. Geol. Fören. Stockh. Förh. 92, 336-346.
- Melin, E., Christiansson, K. and Nilsson, Ö., 1971. Rb-Sr radiometric ages of extrusive and intrusive rocks in northern Sweden. Swedish Geological Survey (SGU) Ca 41. Stockholm.

- Wikberg, P., Grenthe, I. and Axelsen, K., 1983. Redox conditions in groundwaters from Svartboberget, Gideå, Fjällveden and Kamlunge. SKBF/KBS Technical Report TR 83-40. Stockholm.
- Wikberg, P., 1985. The assessment of reducing conditions at depth in granitic rock. In: Scientific Basis for Nuclear Waste Management IX. Stockholm. (In Press).
- Wikström, A., 1978. Geological description of the Katrineholm map sheet (SE). (In Swedish). Swedish Geological Survey (SGU) Af 123. Stockholm.

10. APPENDICES

Appendix 1: Theoretical models on the open-hole effect

1.1 Two conductive zones separated by an impervious layer

Two zones of different hydraulic conductivity separated by an impervious layer are penetrated by a borehole. The groundwater will flow through the borehole from the zone of higher to the zone of lower hydraulic head, and the groundwater level in the borehole will be situated somewhere between the two different piezometric levels. The amount of flow (Q) is determined by the difference in hydraulic head and the hydraulic conductivity of the actual zones.

The flow of water can be calculated from Dupuit's formula:

$$\Delta s = Q / (2\pi KH) \ln(R/r_w) \quad (1-1)$$

where Δs = head difference in the borehole (m)
 Q = flow of water (m³/s)
 K = hydraulic conductivity (m/s)
 H = thickness of the aquifer (zone) (m)
 R = radius of influence (m)
 r_w = radius of the well (m)

As the flow from the zone of higher head (Q_1) is equal to the flow into the zone of lower head (Q_2) the equation becomes:

$$\frac{\Delta s_1 K_1 H_1}{\ln(R_1/r_w)} = \frac{\Delta s_2 K_2 H_2}{\ln(R_2/r_w)} \quad (1-2)$$

$$\text{or } \Delta s_2 = (\Delta s_1 K_1 H_1 / K_2 H_2) R' \quad (1-3)$$

$$\text{where } R' = \ln(R_2/r_w) / \ln(R_1/r_w) \quad (1-4)$$

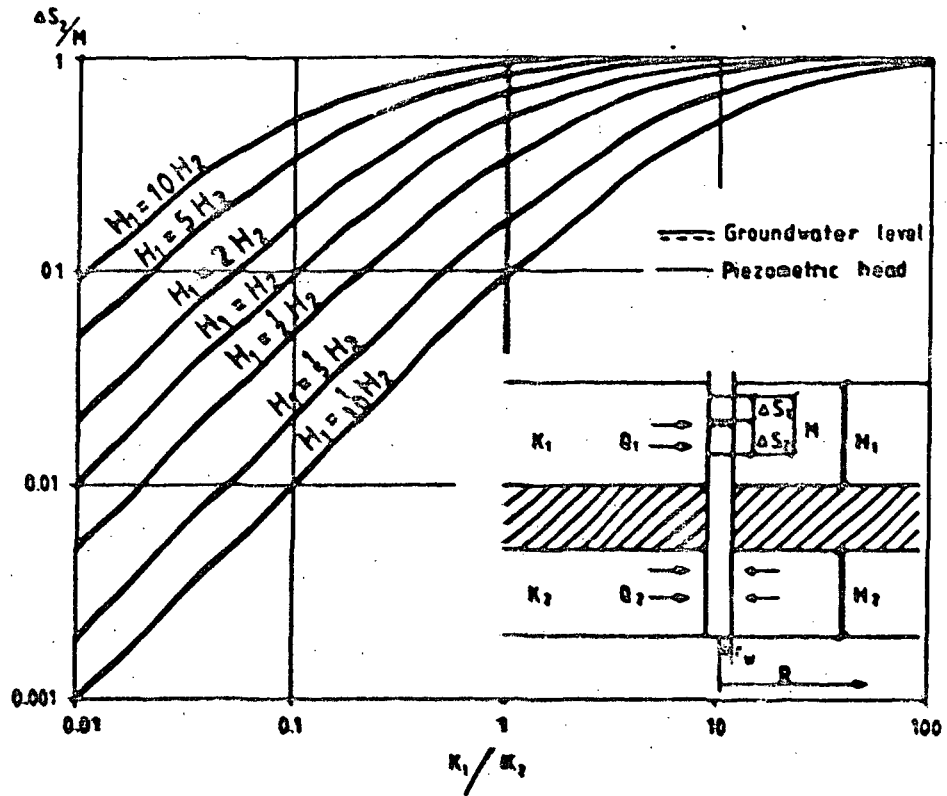

Figure 1.1 Two conductive fracture zones. $\Delta s_2/M$ as a function of K_1/K_2 .

If Δs_1 is the distance from the higher, and Δs_2 the distance from the lower, piezometric level to the equilibrium level, and M is the distance between the two piezometric levels, then $M = \Delta s_1 + \Delta s_2$. Thus

$$\Delta s_2 = (M - \Delta s_2) K_1 H_1 R^2 / K_2 H_2 \quad (1-5)$$

If Δs_2 is expressed as a percentage of M the equation becomes

$$\Delta s_2/M = \frac{(R^2 K_1 H_1 / K_2 H_2)}{(1 + R^2 K_1 H_1 / K_2 H_2)} \quad (1-6)$$

The expression $\ln(R_2/r_w)/\ln(R_1/r_w)$ will probably not exceed 2 or fall below $1/2$.

In Figure 1.1 a set of type curves is presented, showing $\Delta s_2/M$ for different values of K_1/K_2 and H_1/H_2 . These curves show that the greater K_1 and H_1 become, compared to K_2 and H_2 , the closer to the higher piezometric level will the equilibrium level be.

1.2 Two conductive zones separate by a semi-pervious layer

If the layer separating the two conductive zones is not completely impervious, seepage will take place through this layer from the zone of higher to the zone of lower hydraulic head. Thus the flow through the borehole will be somewhat reduced and consequently $\Delta s_2/M$ will be lower.

For an open aquifer above a semi-pervious layer, the following equation applies (Huisman 1972):

$$\Delta s = (Q/2\pi KH)\ln(L/R) \quad (1-7)$$

where L is the leakage factor.

For a confined aquifer below a semi-pervious layer, the equation is (Carlsson and Gustafsson 1984):

$$\Delta s = (Q/2\pi KH)\ln(1.123L/R) \quad (1-8)$$

In a rough estimate it is usually permitted to let $L = R/2$ where R is the radius of influence. If $L = R/2$ and $Q_1 = Q_2$ then Δs_2 as a percentage of M is:

$$\Delta s_2/M = \frac{0.833(K_1 H_1 / K_2 H_2)}{1 + 0.833(K_1 H_1 / K_2 H_2)} \quad (1-9)$$

Figure 1.2 shows a set of type curves of $\Delta s_2/M$ for different values of K_1/K_2 and H_1/H_2 for a leaky two-aquifer model. As can be seen when comparing those curves with those in Figure 1.1, the values of $\Delta s_2/M$ will be lower with leakage than without.

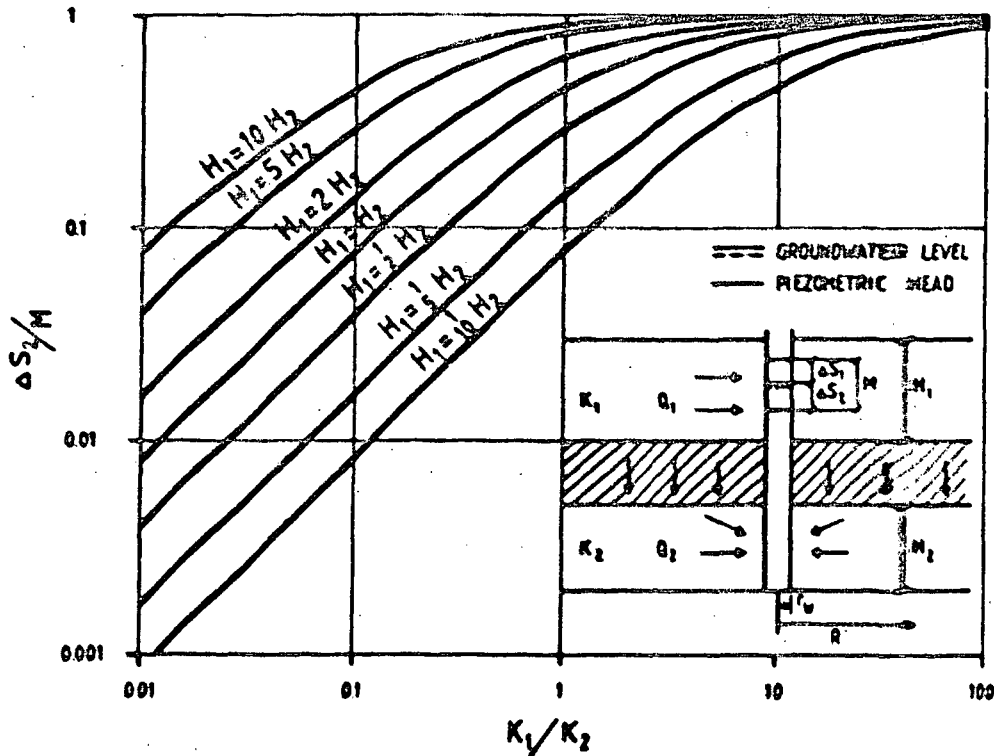

Figure 1.2 Two conductive fracture zones with leakage.
 $\Delta s_2/M$ as a function of K_1/K_2 .

1.3 Three conductive zones, two different hydraulic heads

This model consists of three zones with hydraulic conductivities K_1 , K_2 and K_3 where the hydraulic heads in zones K_2 and K_3 are equal and lower than the head in zone K_1 , c.f. Figure 1.3. The water will flow from the zone of higher to the two zones of lower head.

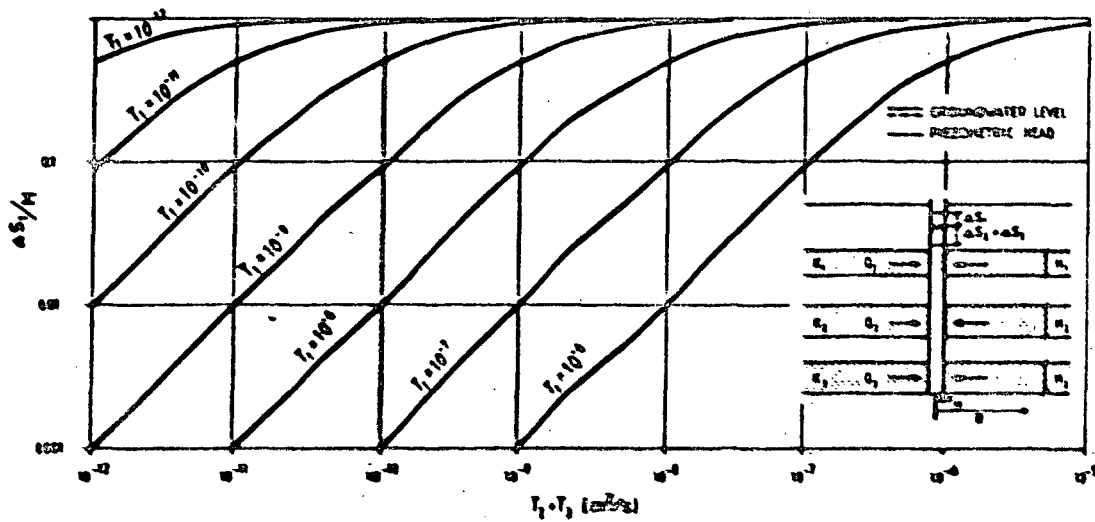

Figure 1.3 Three conductive fracture zones. $\Delta s_1/M$ as a function of $T_2 + T_3$ for different values of T_1 .

Supposing that $R_1 = R_2 = R_3$ and that $Q_1 = Q_2 + Q_3$ leads to:

$$\Delta s_1 K_1 H_1 = \Delta s_2 K_2 H_2 + \Delta s_3 K_3 H_3 \quad (1-10)$$

As $KH = T$ and $\Delta s_2 = \Delta s_3 = M - \Delta s_1$ the equation (1-10) becomes:

$$\Delta s_1 (T_1 + T_2 + T_3) = M(T_2 + T_3) \quad (1-11)$$

$$\text{or } \Delta s_1/M = (T_2 + T_3)/(T_1 + T_2 + T_3) \quad (1-12)$$

In Figure 1.3 a set of typecurves are presented, showing $\Delta s_1/M$ as a function of $T_2 + T_3$ for different values of T_1 .

1.4 Three zones of different hydraulic conductivity and head

In this case water will flow from the zone(s) of higher to the zone(s) of lower hydraulic head. In the following discussion it is assumed that the water flows from one zone of higher head to two zones of lower head. M is the distance from the highest to the lowest head and N is the distance from the highest to the intermediate head. If the intermediate level is situated centrally between the highest and the lowest level, then the situation will be the same as the one described in section 1.1.

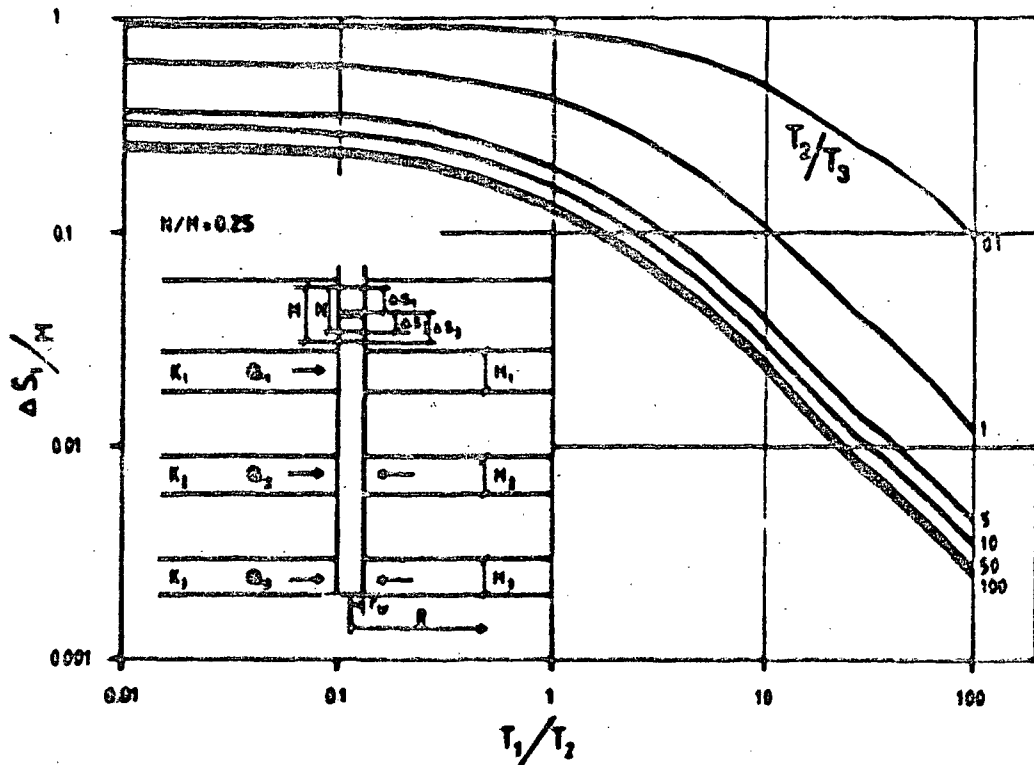

Figure 1.4 Three conductive fracture zones. $\Delta S_1/M$ as a function of T_1/T_2 for different values of T_2/T_3 . $N/M = 0.25$.

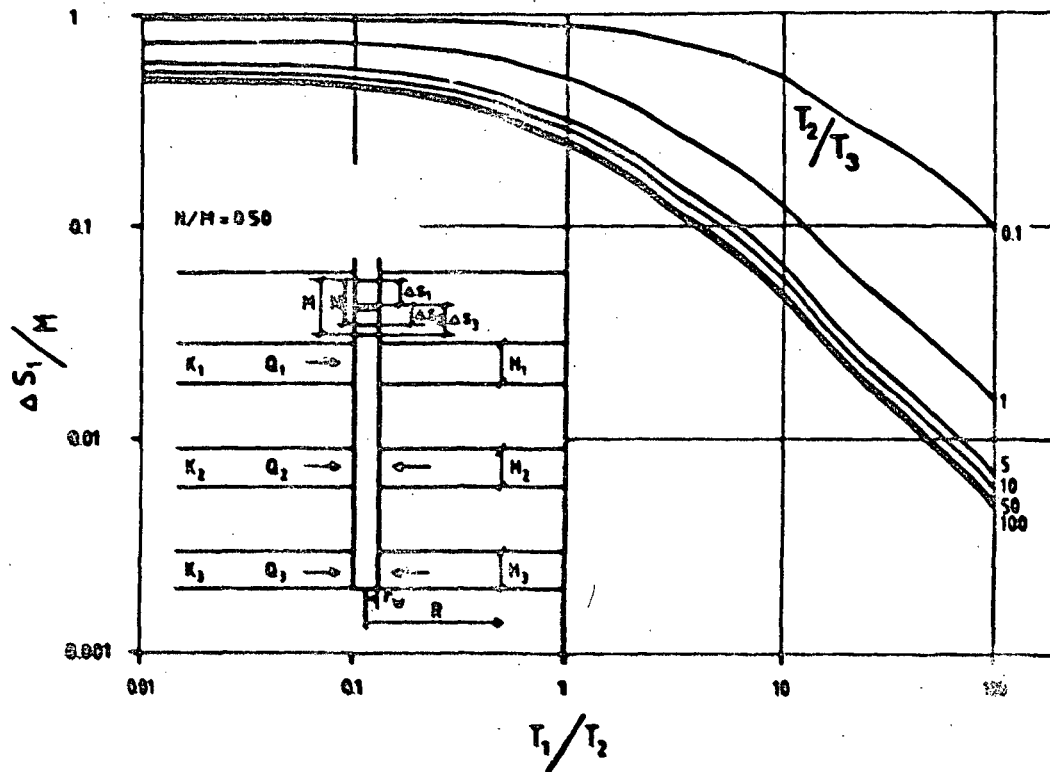

Figure 1.5 Three conductive fracture zones. $\Delta s_1/M$ as a function of T_1/T_2 for different values of T_2/T_3 . $N/M = 0.5$.

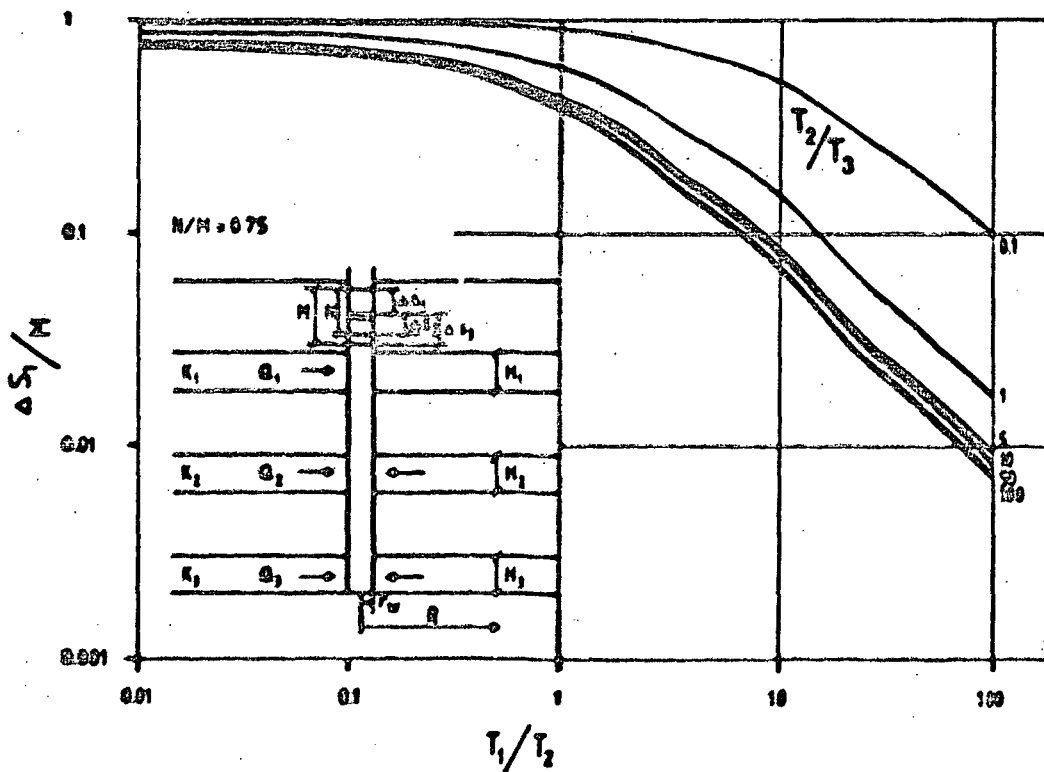

Figure 1.6 Three conductive fracture zones. $\Delta s_1/M$ as a function of T_1/T_2 for different values of T_2/T_3 . $N/M = 0.75$.

If $R_1 = R_2 = R_3$ and $Q_1 = Q_2 = Q_3$ the flow equation becomes:

$$\Delta s_1 K_1 H_1 = \Delta s_2 K_2 H_2 + \Delta s_3 K_3 H_3 \quad (1-13)$$

As $M = \Delta s_1 + \Delta s_3$ and $N = \Delta s_1 + \Delta s_2$ and $KH = T$ the equation (1-13) can be written:

$$\Delta s_1 T_1 = T_2 (N - \Delta s_1) + T_3 (M - \Delta s_1) \quad (1-14)$$

$$\text{or } \Delta s_1 / M = \frac{(N/M)T_2 + T_3}{T_1 + T_2 + T_3} \quad (1-15)$$

Three sets of type curves are drawn in Figures 1.4, 1.5 and 1.6 for three different values of N/M , 0.25, 0.5 and 0.75, showing the variations in $\Delta s_1 / M$ for different values of T_1 / T_2 and T_2 / T_3 .

Appendix 2: Numerical calculations of the open-hole effect

A generic model based on geometrical data from the Kamlunge site is calculated by the finite element program GEOFEM-G (Runesson et al, 1979). The object is to illustrate the influence on the groundwater head of a borehole sited in the central part of a circular area having a diameter of 3.2 km. The area comprises a large hill with a relative height difference of 120 m, surrounded by a "circular" fracture zone in the circumjacent valley. A section through the hill is given in Figure 2.1, where the boundary conditions used in the model calculations are also shown. The total depth of the calculated section is 1000 m.

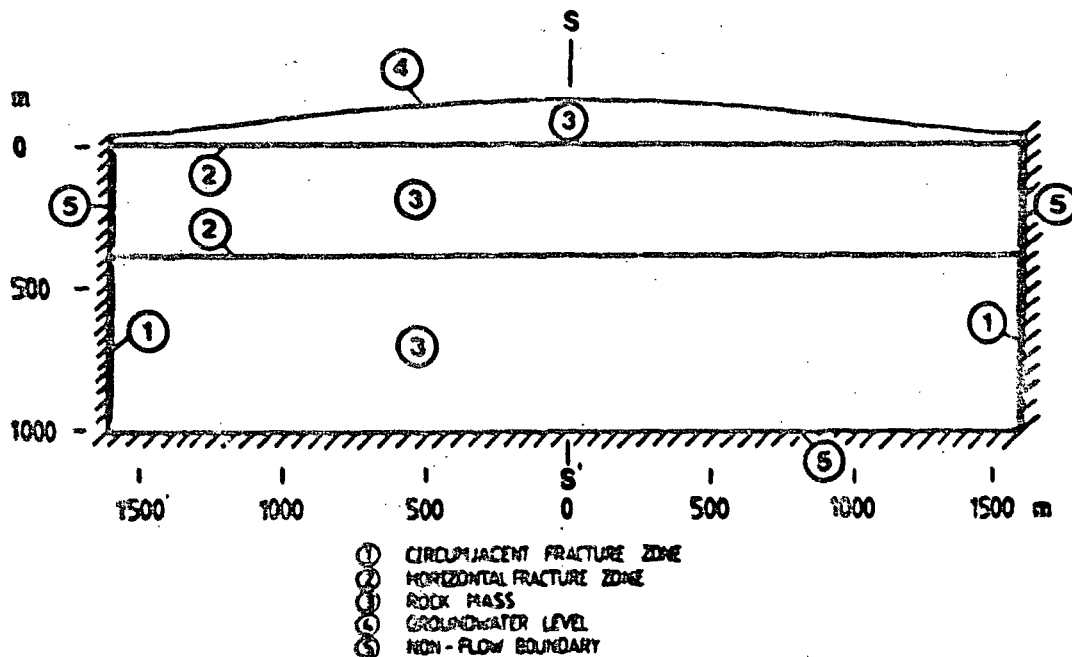

Figure 2.1 Section through the generic area modelled with boundary conditions given in the calculations.

The calculations are performed in a sequence comprising 1) calculation without a borehole, 2) calculations only within a borehole and 3) calculations where account is taken of the borehole in the studied models. Based on the boundary conditions given in Figure 2.1, the hydraulic head is calculated within the complete studied area.

The element net used is shown in Figure 2.2. Due to axial symmetry only half of the section shown in Figure 2.1 is used in the numerical calculations.

Four different cases are studied with different hydrogeological parameters and conditions as shown in Figure 2.3. In the cases A and B, a constant hydraulic conductivity is allocated to the rock mass. In the cases C and D the hydraulic conductivity decreases with depth according to the formula given by Carlsson et al, (1983) for the Kamlunge site:

$$K = 7.91 \times 10^{-3} \cdot Z^{-3.17} \quad (2-1)$$

where Z is the depth below ground surface ($Z > 50$ m).

In the cases B and D, influences are illustrated where upon two horizontal continuous fracture zones, with a thickness of 10 m each, extend through the whole model. These fracture zones are given a hydraulic conductivity of $1 \cdot 10^{-7}$ m/s, while the outer limiting "circular" zone has a conductivity value of $1 \cdot 10^{-6}$ m/s. The results of the calculations shown as lines of equal potentials are given in Figure 2.4, 2.5, 2.6 and 2.7.

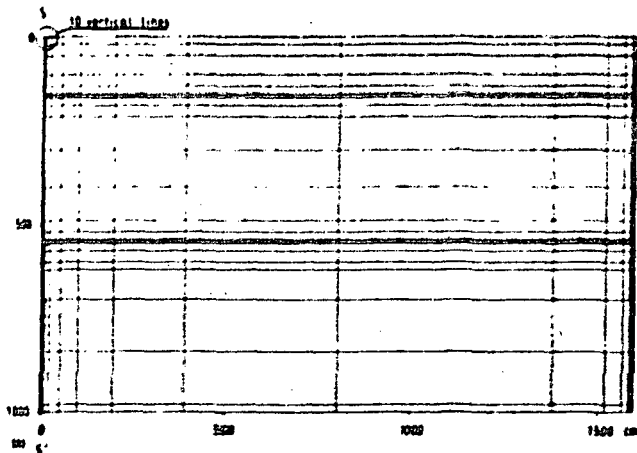

Figure 2.2 Element-net used in FEM-calculations of the studied area.

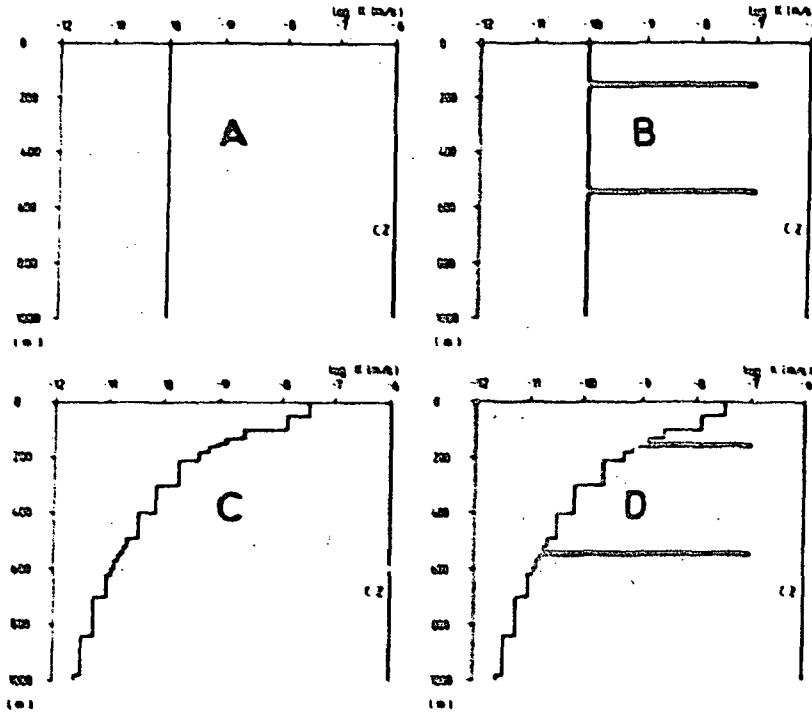

Figure 2.3 Hydraulic conductivity versus depth in the different cases studied. c.z. = circumjacent fracture zone.

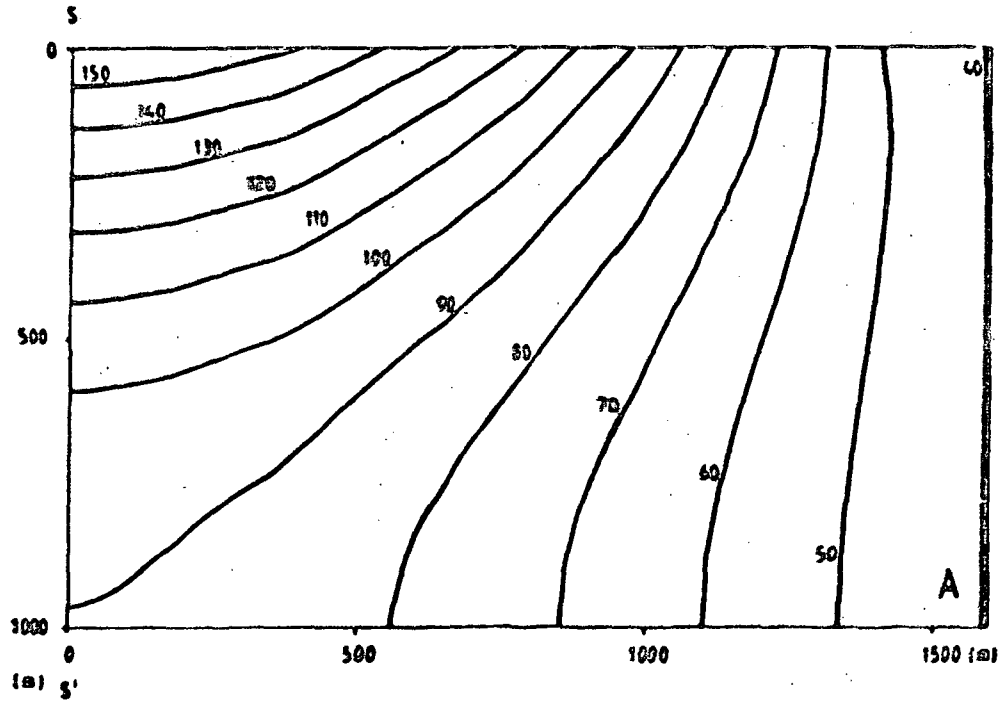

Figure 2.4 Groundwater head distribution for case A. Lines of equal potentials in m.

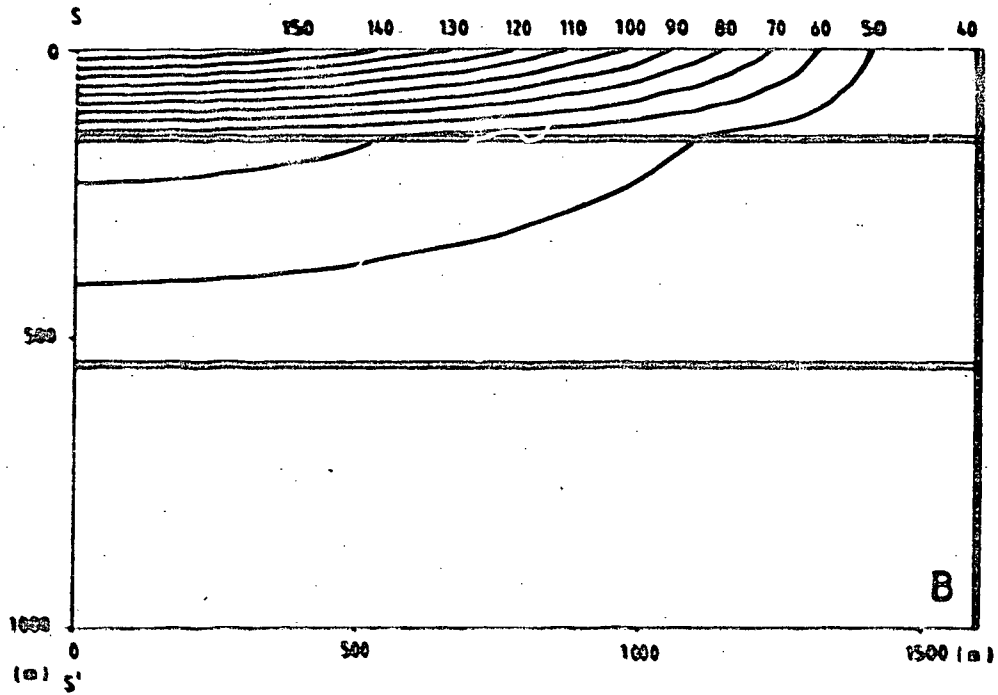

Figure 2.5 Groundwater head distribution for case B. Lines of equal potentials in m.

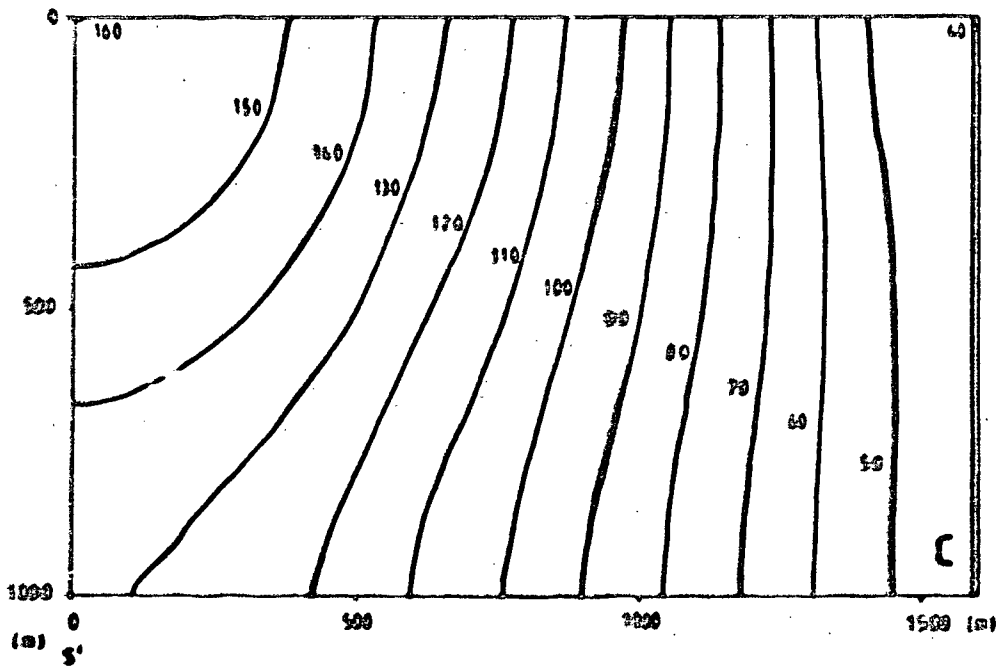

Figure 2.6 Groundwater head distribution for case C. Lines of equal potentials in m.

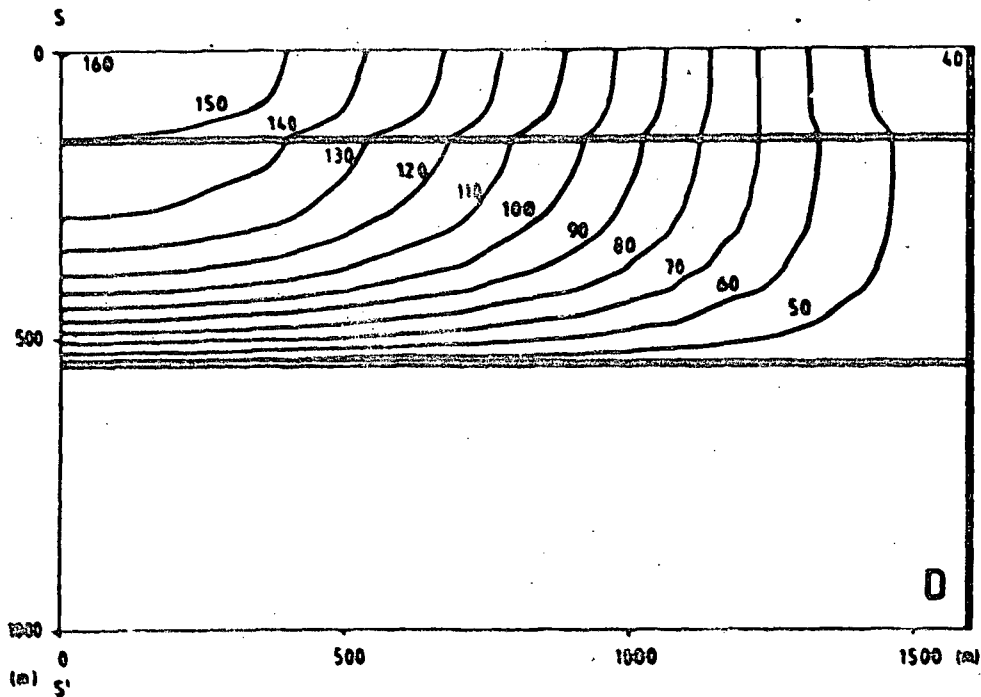

Figure 2.7 Groundwater head distribution for case D. Lines of equal potentials in m.

Along the symmetric line S-S' in Figure 2.1, a borehole is drilled to 600 m depth. The hydraulic head profile along the line before the borehole is drilled is illustrated in Figure 2.8 for the different cases considered. Based on these profiles the groundwater level within the borehole is calculated assuming that the water balance is maintained in the hole (i.e. constant groundwater level). Furthermore, the influence radius on the groundwater head from the borehole is assumed to be the same, disregarding the hydraulic conductivity value of the surrounding rock. The analytically calculated level for the different cases are shown in Table 2.1.

The second and last runs of numerical calculations comprise models where the groundwater level in the borehole is given as boundary conditions along the upper 600 m of the symmetry axis S-S'. This will illustrate the effect of the borehole on the hydraulic head and also result in values of the groundwater flow within the borehole (from and to the surrounding bedrock).

Table 2.1. Calculations of the groundwater level in 2 600 m deep borehole sited in the centre of the studied model, and of the groundwater in- and outflow within the borehole. For the analytical and numerical calculations for different cases studied, see Figure 2.3.

Case	Calculated groundwater level (m below the gw-level in the uppermost bedrock i.e 160 m)	Annual exchange of groundwater within the borehole (m ³ /year)
A	36.3	9
B	106.1	190
C	0.3	10
D	28.6	1500

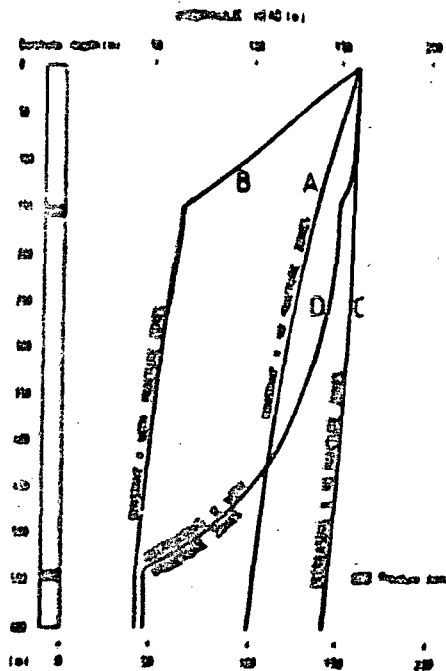

Figure 2.8 Groundwater head along the S-S' symmetry axis before the drilling.

The results, shown as lines of equal potentials, are given in Figures 2.9, 2.10, 2.11 and 2.12. To illustrate the influence on the hydraulic head positioned horizontally out from the borehole, two sections of head at 160 m and at 550 m respectively down the borehole are shown in Figures 2.13 and 2.14. In these figures the head increase or decrease in relation to the conditions before the borehole was drilled is given as a function of the radial distance from the borehole for the different cases considered under steady state conditions. The greatest influence is obtained in case D where horizontal fractures exist in the rock mass which has a decreasing hydraulic conductivity with depth. In the case of a constant hydraulic conductivity with depth (case A) a large head influence is also obtained. However, the influence distance into the bedrock is greatest when horizontal fractures are present.

The groundwater flow into and out from the borehole is given in Table 2.1 for the different cases considered. It should be noted that in the cases with fracture zones, these are the main channels for in and outflow within the borehole.

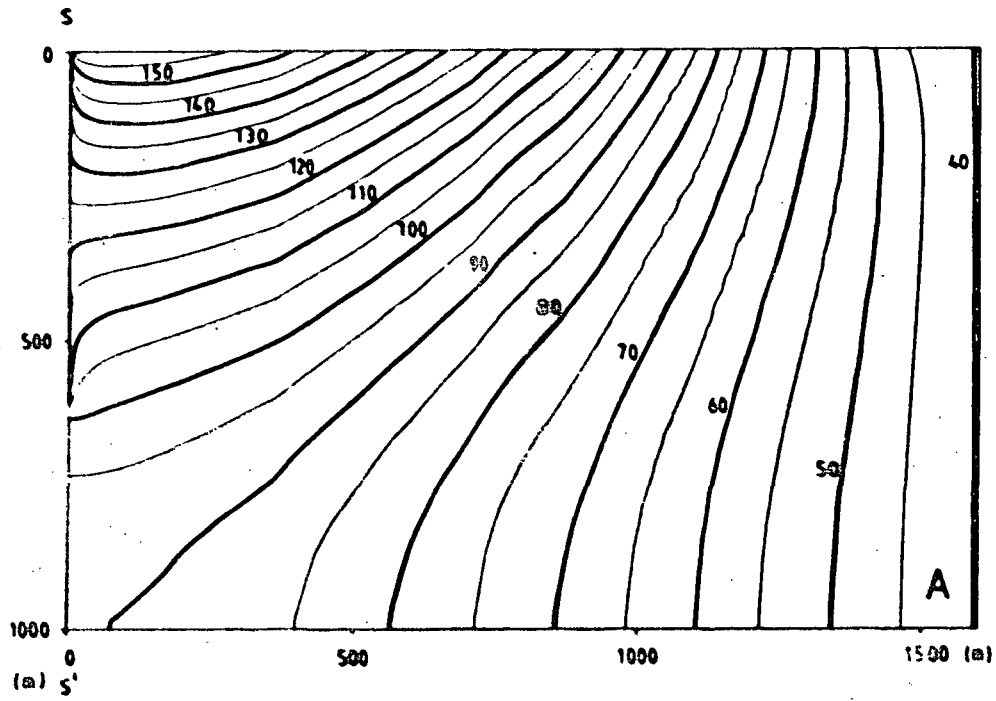

Figure 2.9 Groundwater head distribution for case A with a borehole 600 m deep along the axis of symmetry. Lines of equal potentials in m.

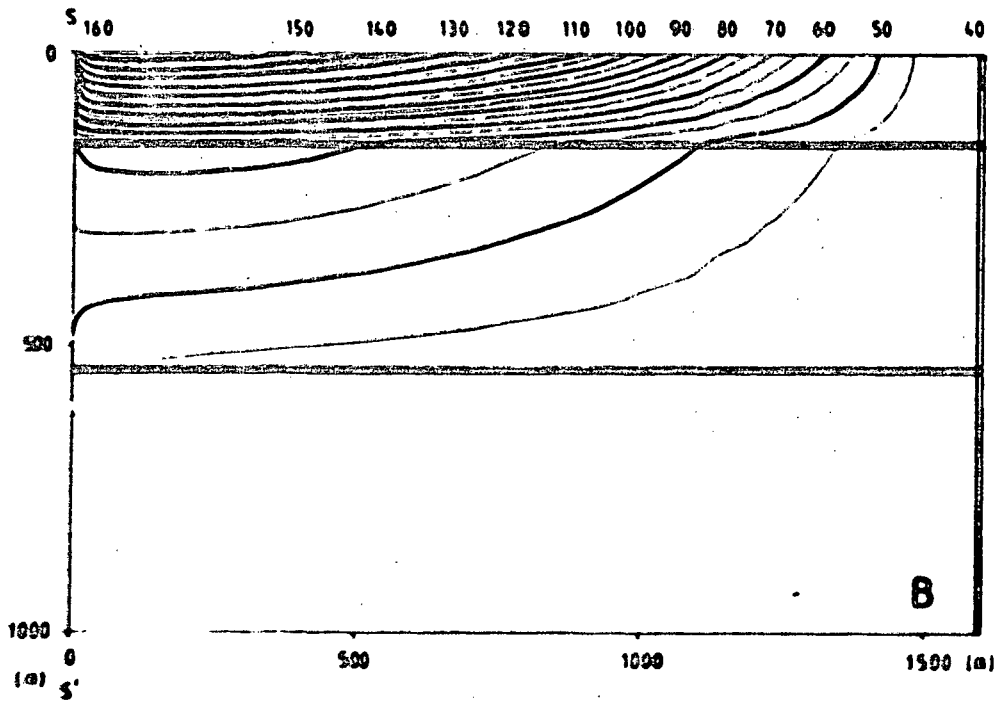

Figure 2.10 Groundwater head distribution for case B with a borehole 600 m deep along the axis of symmetry. Lines of equal potentials in m.

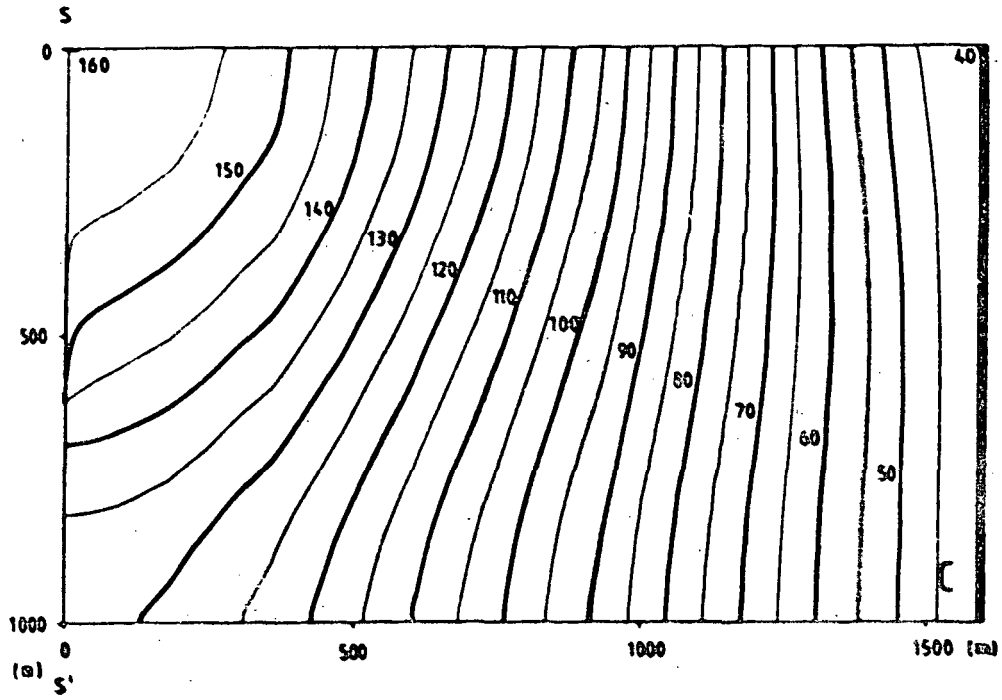

Figure 2.11 Groundwater head distribution for case C with a borehole 600 m deep along the axis of symmetry. Lines of equal potentials in m.

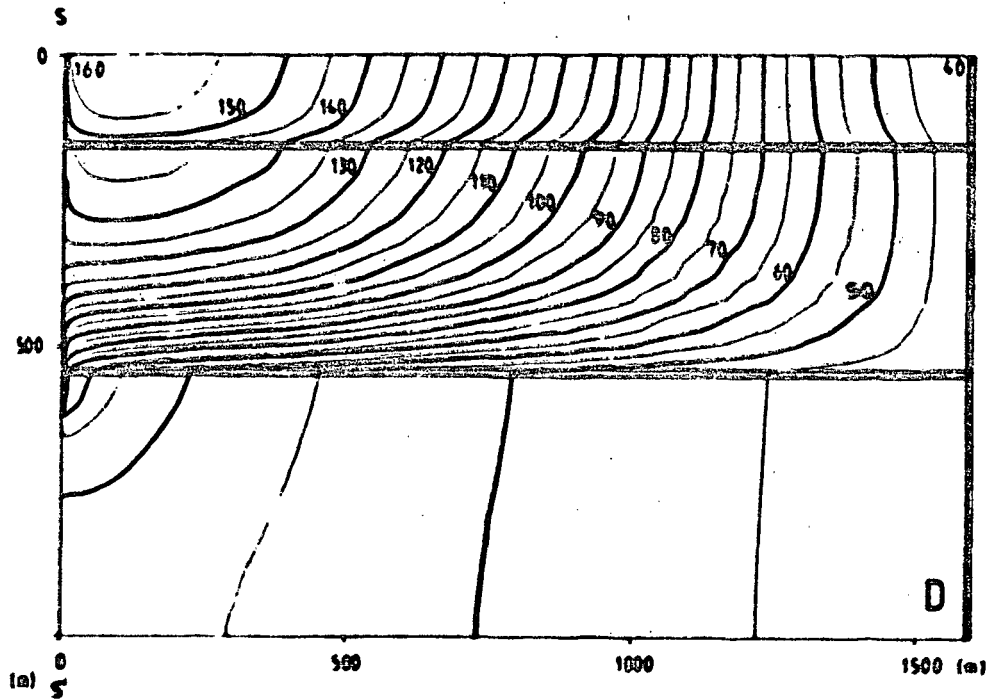

Figure 2.12 Groundwater head distribution for case D with a borehole 600 m deep along the axis of symmetry. Lines of equal potentials in m.

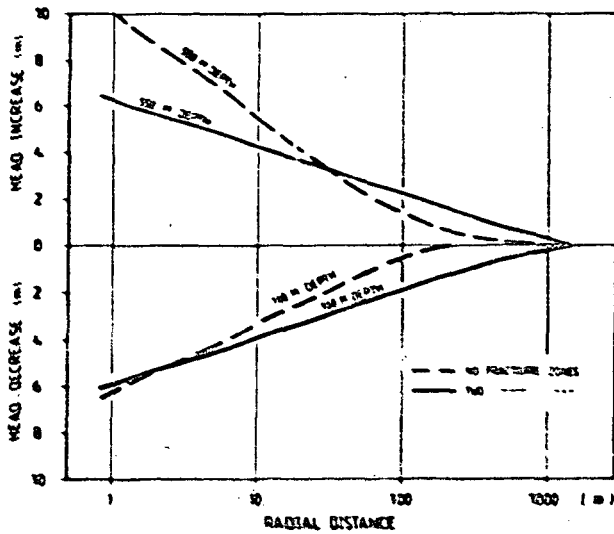

Figure 2.13 Groundwater influence as the difference in head before and after the drilling along a horizontal profile from the borehole out in the bedrock (steady state). Cases A and B.

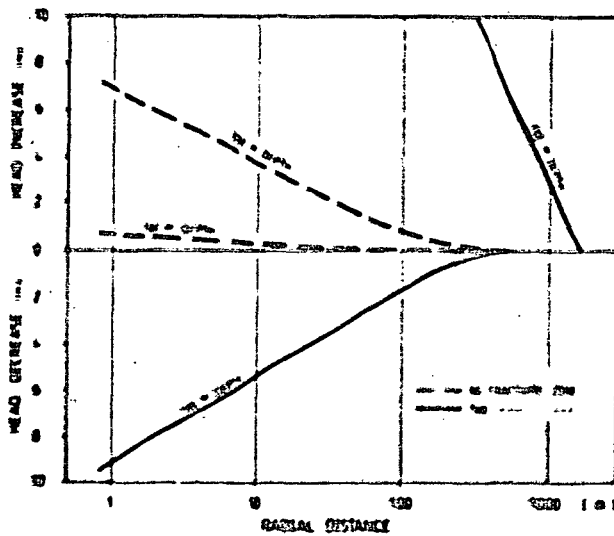

Figure 2.14 Groundwater influence as the difference in head before and after the drilling along a horizontal profile from the borehole out in the bedrock (steady state). Cases C and D.

Appendix 3: Groundwater pump flow-rate and its effect on some physico-chemical parameters - controlled experiments carried out at Kamlunge and Taavinunnenen.

3.1 Kamlunge

Controlled conditions were established at the 238 m level in drillhole Km 8 following the completion of the normal groundwater sampling programme (see Section 5.4.3). The object of the experiment was to record any evidence that the physico-chemical characteristics of the groundwaters are influenced by changes in the groundwater pump flow-rate.

Monitoring trends of Eh, pS, O_2 , conductivity and temperature are presented in Figure 3.1, together with 15 (out of a total of 24) groundwater analyses showing the variation of dissolved uranium contents and the $^{234}U/^{238}U$ isotopic activity ratios. With the exception of pH, all measured physico-chemical parameters indicate some level of variation that can be mostly attributed to changes in the groundwater pump flow-rate.

Generally, the results indicate that by lowering the groundwater flow-rate by half, there is a change to groundwaters of a more reducing nature, i.e. reduction in O_2 , pS, Eh and increase in conductivity. In addition, during the first 20 to 25 hours after restarting pumping, the groundwaters were more reducing than in the latter half of the first pumping period. The extreme values recorded within the first 1 to 2 hours represent water which was trapped in the cable system during the pump halt. Contamination due to drilling water is not thought to be a major problem as this experimental run was carried out after 27 days continuous pumping at the same level. This is supported by the very low iodine tracer values which ranged between 0.01-0.03 % I⁻ during the sampling period (Laurent, 1983d).

The data thus suggest that the groundwaters representing the start of the experimental run become increasingly mixed with waters of a less reducing character (higher oxygen content); this appears to reach a maximum between 40 and 50 hours. The subsequent marked decrease (between 50 and 60 hours) before levelling out, probably indicates a return to more reduced (i.e. normal) conditions. During the reduced flow-rate period, the groundwaters are virtually free of oxygen and, together with the other physico-chemical parameters, suggest typical reduced groundwater conditions. Increase of the groundwater flow-rate once again introduces contamination by less reducing waters.

The presence of more oxygenated groundwaters at high pump flow-rates point to two main possible conducting pathways:

- groundwater derived (via interconnecting fracture systems) from higher, more oxygenated levels in the bedrock.
- near-surface derived borehole water obtained via a short circulating fracture network between the fracture horizon and the borehole.

3.1.1. Conclusions

The recorded observations appear to be wholly dependent on the pump flow-rate. A high pump flow-rate (in this case 260 ml/min) introduces mixing and thus contamination of the groundwater, a situation which is not apparent at the lower flow-rate. It would seem that at the lower pump flow-rate, the groundwater results from within the main fracture zone and its immediate surroundings, and that the hydraulic capacity of the fracture can accommodate the volume required from the pumping. At a higher pump-rate, however, the hydraulic capacity of the fracture zone is inadequate so that other groundwater sources, which may result in contamination, are tapped.

The following points resulting from this investigation are considered important:

- 1) Changes in the pump flow-rate has resulted in significant variations in the physico-chemical parameters of groundwaters.
- 2) High pump flow-rates have resulted in an increase of oxygen in the groundwaters. This may be due to mixing of waters from higher, more oxidised sources, or, contamination from surface-waters which have percolated from the drill-hole area.
- 3) Low pump flow-rates have resulted in groundwaters which are truly reducing in character. These are more representative of the depth (238 m) at which the experiment has been carried out.
- 4) The results show that dissolved uranium and the $^{234}\text{U}/^{238}\text{U}$ activity ratio are subject to changes in flow conditions.

3.2 Taavinunnanen

In order to further investigate the effects recorded at Kamunge, a similar experiment was carried out at Taavinunnanen (level 493 m). Normal groundwater sampling from level 493 m at Taavinunnanen had been carried out for two, eight-day periods; continuous pumping (apart from an approx. 3 day unscheduled pump-halt between the two sampling periods) had therefore been in operation for a total of 22 days. From the end of the second period to the conclusion of the experiment, a total of 14 days were available and these were subdivided as follows:

- During the rest period following the end of the second sampling programme, the groundwater pump flow-rate was increased from 190 ml/min to 260 ml/min.

- The experimental run was begun after the rest period; the groundwater was monitored and sampled before decreasing the flow-rate to approx. 60 ml/min. Pumping at this rate was continued for 4 days.
- Groundwater flow-rate was increased to 150 ml/min and maintained at this level for 2 days.
- Groundwater flow-rate was further increased back to the initial flow-rate of 260 ml/min; this was maintained for 1.5 days.

During this period Eh, O₂, pS, pH, temp. and conductivity were continually monitored, and two groundwater samples were collected daily for chemical analysis which included dissolved uranium, ²³⁴U and ²³⁸U isotopes, and tritium.

3.2.1 Results and Discussion

Because of the available information throughout the groundwater sampling programme at level 493 m, the results from all three period (the third period being the experimental run) are presented in Figure 3.2. The chemical parameters illustrated, represent those which indicated a systematic variation that may be partly attributable to groundwater pump flow-rates.

3.2.1.1 Redox-sensitive parameters

Initial Sampling Periods

During the first sampling period, whereupon initial groundwater contamination is to be expected after drilling, hydraulic testing, and gas-lift pumping to clear the hole, it took approximately 4 days before the groundwater approached more representative reducing conditions. However, this was followed by an influx of

increasingly oxygenated water which might indicate a short-circuiting between the fracture zone under investigation and the water in the borehole above the packer system. During the rest period before the second sampling phase, there was a pump halt for up to 3 days. Renewed pumping at the beginning of the second sampling period thus took a further 3 days to remove the residual contaminating water that had entered the fracture zone during the latter half of the first sampling period and up to the time of the pump halt.

Although a similar pump flow-rate was used during both periods, the groundwater for the latter 4 days of the second sampling period continued to stabilise without showing any significant increase of more oxygenated groundwater.

Experimental Period

For the six days prior to the experimental run, the groundwater flow-rate was increased to a maximum (260 ml/min). During this period, O_2 , pS, Eh and pH (especially laboratory measurements) increased and the conductivity decreased. Thus, at the beginning of the experimental run, the groundwater characteristics were approximately similar to the groundwater experienced at the beginning and the end of the first sampling period, and at the beginning of the second sampling period. This would suggest, therefore, that the short-circuiting paths, via fracture/fissure systems in the bedrock to the borehole water above the packer system, had been reactivated due to the higher pump-rate.

Reduction of the groundwater flow-rate to 60 ml/min produced over the next four days, a gradual reduction of pS, Eh, pH, and an increase of conductivity. Groundwater stabilisation at this flow-rate did not occur; at least a further 5-7 days would have been required. It was therefore decided to increase the water flow-rate to 150

ml/min. As a result, the pS and Eh continued to decrease and conductivity and pH increased; increasingly more reducing groundwater was therefore being encountered. After approximately 1.5 days, however, the trend began to be reversed as the effect of the higher flow-rate began to set up a partial vacuum which responded by bringing in less reducing groundwater again. This effect is seen as levelling out of Eh and pH and a small reduction in conductivity. These effects were further accentuated as the flow-rate was increased to a maximum for the final 2.5 days. Eh at this stage indicated small increases (electrodes Pt1 and C2); O_2 also suggested a small increase.

3.2.1.2 General groundwater chemistry

Of all the measured anions and cations, Ca^{2+} , Na^+ , Fe (total) and F^- showed the most systematic variations. In general, Ca^{2+} , Na^+ and F^- decreased during the initial sampling period, increased during the three day pump stop, and then decreased again during the second period until the groundwater composition stabilised. The experimental period indicated small systematic increases with the increase in pump flow-rate. Total Fe in comparison, suggested a antipathetic relationship; the Fe(II) analyses are not reliable for comparison.

Uranium varied in a similar manner to Ca^{2+} , Na^+ and F^- and noticeably decreased in content with increasingly reducing conditions. The $^{234}U/^{238}U$ activity ratio showed no obvious systematic variation.

As described in Section 5.5.1.1., the tritium contents were very high. No variation was indicated during the sampling periods; however, sharp fluctuations occurred throughout the experimental period for which there is no apparent systematic relationship with the pump flow-rate. Minimum values were encountered subsequent to increasing

the pump flow-rate to 150 ml/min but after one day sharply increased and levelled out for the rest of the experimental run. This variation probably indicated the influx of other sources as the flow-rate was increased.

3.2.1.3 Representative groundwaters

The hydrochemical sampling programme carried out at Taavinunnen illustrates the difficulty in knowing which sampled groundwaters are most representative for the bedrock level (493 m). At best, the groundwaters are only representative for the artificially-imposed groundwater flow-rate, which may or may not be similar to the groundwater that might be collected under normal hydraulic pressure. From the available data, the most representative groundwater for potential chemical examination and rock/water interaction studies, would be that obtained during the last two days of the second sampling period. As indicated during the experimental run, more reducing groundwater can be obtained at lower groundwater flow-rates, which might be even more representative. From a practical point of view, however, sampling at these low flow-rates is tedious and time-consuming, but not impossible.

3.2.2 Conclusions

Examination of all the data from level 493 m at Taavinunnen, illustrates the following main points:

- 1) Several groundwater compositions are encountered as a result of surface or near-surface water contamination.
- 2) These variations are reflected both by parameters such as Eh, pS, pH, conductivity and oxygen content, and also by the ionic variation of especially Na^+ , Ca^{2+} , F^- total Fe and uranium.

- 3) These variations, resulting from surface or near-surface water contamination, are thought to be caused by: a) short-circuiting, via bedrock fractures/fissures, between the sampled fracture zone and the borehole water above the packer system, and/or b) borehole water being forced down between the packers and the borehole walls, and/or c) higher-level, more oxygenated groundwaters from within the bedrock. Point a) and possibly b) are considered the most likely causes.
- 4) Adjusting the groundwater flow-rates to different capacities has resulted in different groundwater types.
- 5) Of the hydrochemical sampling programme carried out during the first two periods, only the groundwater from the last two days of the second period are considered representative.
- 6) The results generally confirm the findings from the Kamlung test-run.

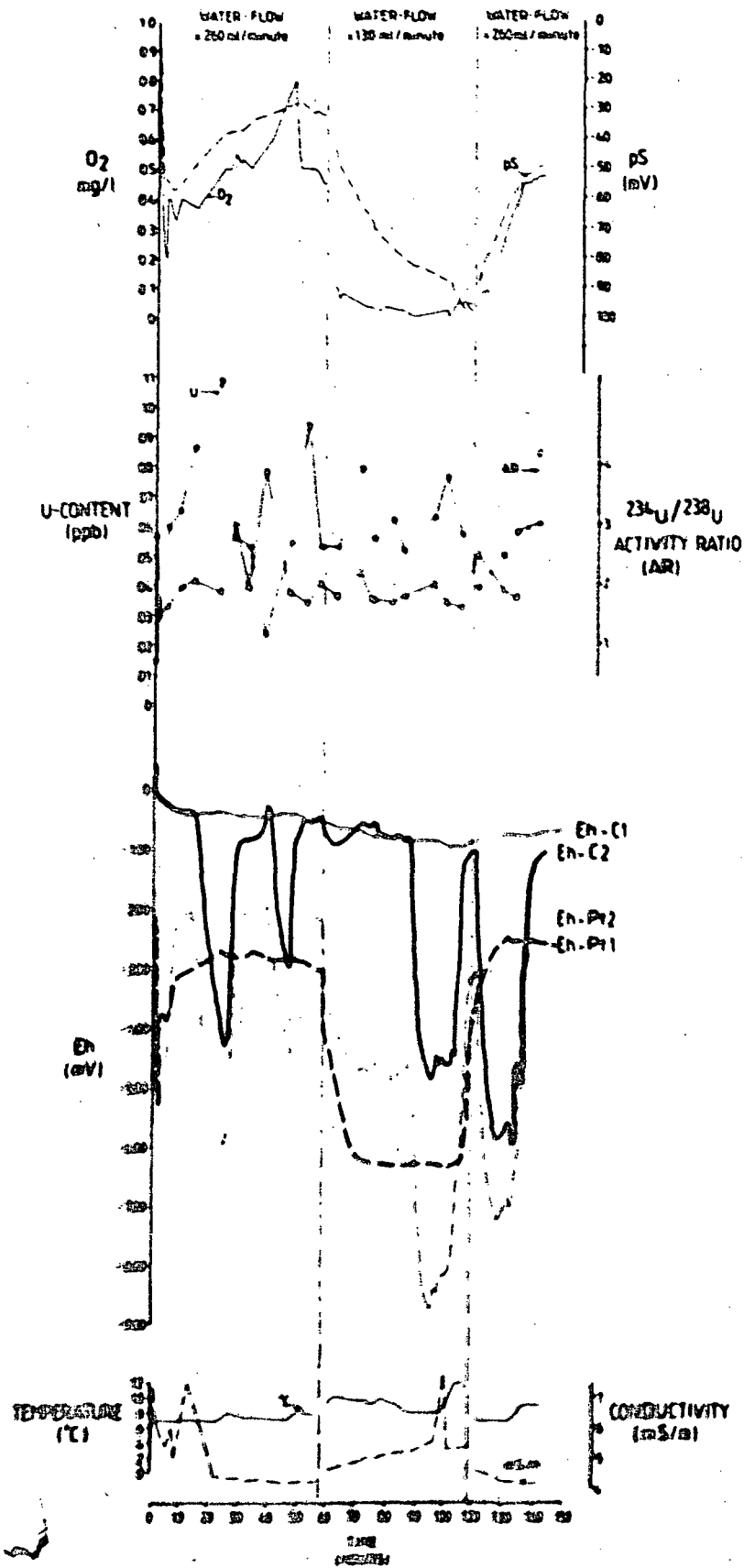

Figure 3.1: The variation of some groundwater physico-chemical parameters with changes in the pump flow-rate. (Kamlunge).

TAIVINUMAKEN
Level 493m

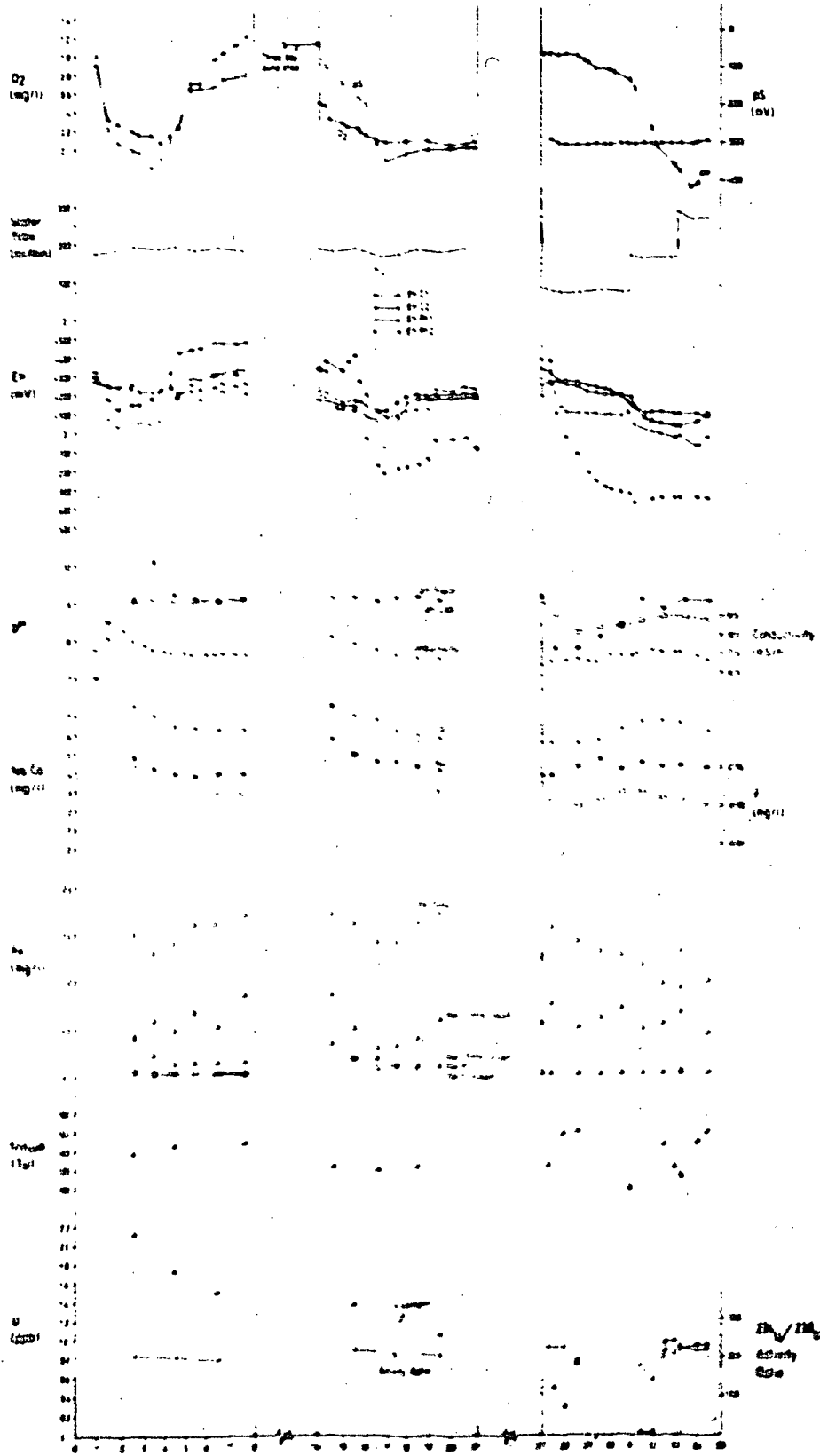

Figure 3.2: The variation of some groundwater physico-chemical parameters with changes in the pump flow-rate. (Taavinumaken).

List of Technical Reports

1977-78

TR 121

KBS Technical Reports 1 - 120.

Summaries. Stockholm, May 1979.

1979

TR 79-28

The KBS Annual Report 1979.

KBS Technical Reports 79-01 - 79-27.

Summaries. Stockholm, March 1980.

1980

TR 80-26

The KBS Annual Report 1980.

KBS Technical Reports 80-01 - 80-25.

Summaries. Stockholm, March 1981.

1981

TR 81-17

The KBS Annual Report 1981.

KBS Technical Reports 81-01 - 81-16.

Summaries. Stockholm, April 1982.

1982

TR 82-28

The KBS Annual Report 1982.

KBS Technical Reports 82-01 - 82-27.

Summaries. Stockholm, July 1983.

1983

TR 83-77

The KBS Annual Report 1983.

KBS Technical Reports 83-01 - 83-76

Summaries. Stockholm, June 1984.

1984

TR 85-01

Annual Research and Development Report 1984

Including Summaries of Technical Reports issued during 1984. (Technical Reports 84-01-84-12)
Stockholm June 1985.

1985

TR 85-01

Annual Research and Development Report 1984

Including Summaries of Technical Reports issued during 1984.
Stockholm June 1985.

TR 85-02

The Taarnunnanen gabbro massif.

A compilation of results from geological, geophysical and hydrogeological investigations.

Bengt Gentschein

Eva-Lena Tullberg

Swedish Geological Company

Uppsala, January 1985

TR 85-03

Porosities and diffusivities of some non-sorbing species in crystalline rocks.

Kristina Skagius

Ivars Neretnieks

The Royal Institute of Technology

Department of Chemical Engineering

Stockholm, 1985-02-07

TR 85-04

The chemical coherence of natural spent fuel at the Oklo nuclear reactors.

David B. Curtis

New Mexico, USA, March 1985

TR 85-05

Diffusivity measurements and electrical resistivity measurements in rock samples under mechanical stress.

Kristina Skagius

Ivars Neretnieks

The Royal Institute of Technology

Department of Chemical Engineering

Stockholm, 1985-04-15

TR 85-06

Mechanical properties of granitic rocks from Gideå, Sweden

Christer Ljunggren

Ove Stephansson

Ove Alrn

Hossein Hakami

Ulf Mattila

Div of Rock Mechanics

University of Luleå

Luleå, Sweden, October 1985

TR 85-07

Complex forming properties of natural occurring fulvic acids

Part 1. Complexes with cadmium, copper and calcium

Jacob A. Marinsky,

A. Mathaiju,

M. Sicking and

J. Eptzaim

State University of New York at Buffalo

Buffalo, New York 14214,

July 1985

TR 85-08

In situ one-year burial experiments with simulated nuclear waste glasses

Larry L Hench, Derek Spilman and T Buonaquisti

College of Engineering, Univ. of Florida,
Gainesville, USA

Alexander Lööfding

Chalmers Univ. of Technology, Gothenburg,
Sweden

Lars Werme

SKB, Stockholm, Sweden

TR 85-09

Concentration and distribution of natural radionuclides at Klipperåsen and Bjulebo, Sweden

Björn Sundblad, Ove Landström, Rune Axelsson
Studsvik Energiteknik AB, Nyköping, Sweden

TR 85-10

Chemical interactions between the bentonite and the natural solutions from the granite near a repository for spent nuclear fuel

Bertrand Fritz and Marie Kam

Université Louis Pasteur de Strasbourg, Insti-
tut de Géologie, France

July 1985