

AREA  
NV  
Persh  
Colado  
Final

6602031

HN-00020-1098

# COLADO GEOTHERMAL RESOURCE ASSESSMENT FINAL REPORT

SHALLOW HOLE TEMPERATURE SURVEY  
INTERMEDIATE DEPTH HOLES IGH #1 AND #2  
DEEP TEST HOLE 44X-10

UNIVERSITY OF UTAH  
RESEARCH INSTITUTE  
EARTH SCIENCE LAB.

NILE O. JONES

SEPTEMBER, 1982

WORK PERFORMED UNDER CONTRACT  
DE-AC08-79ET27008

GETTY OIL COMPANY

P. O. BOX 11148  
BAKERSFIELD, CA 93389

PREPARED FOR:  
U. S. DEPARTMENT OF ENERGY  
NEVADA OPERATIONS OFFICE  
BY HOLMES & NARVER, INC.  
UNDER CONTRACT DE-AC08-76NV00020

DISCLAIMER

THIS REPORT WAS PREPARED AS AN ACCOUNT OF WORK SPONSORED BY THE UNITED STATES GOVERNMENT. NEITHER THE UNITED STATES NOR THE UNITED STATES DEPARTMENT OF ENERGY, NOR ANY OF THEIR EMPLOYEES, MAKES ANY WARRANTY, EXPRESS OR IMPLIED, OR ASSUMES ANY LEGAL LIABILITY OR RESPONSIBILITY FOR THE ACCURACY, COMPLETENESS, OR USEFULNESS OF ANY INFORMATION, APPARATUS, PRODUCT, OR PROCESS DISCLOSED, OR REPRESENTS THAT ITS USE WOULD NOT INFRINGE PRIVATELY OWNED RIGHTS. REFERENCE HEREIN TO ANY SPECIFIC COMMERCIAL PRODUCT, PROCESS, OR SERVICE BY TRADE NAME, MARK, MANUFACTURER, OR OTHERWISE, DOES NOT NECESSARILY CONSTITUTE OR IMPLY ITS ENDORSEMENT, RECOMMENDATION, OR FAVORING BY THE UNITED STATES GOVERNMENT OR ANY AGENCY THEREOF. THE VIEWS AND OPINIONS OF AUTHORS EXPRESSED HEREIN DO NOT NECESSARILY STATE OR REFLECT THOSE OF THE UNITED STATES GOVERNMENT OR ANY AGENCY THEREOF.

PRINTED IN THE UNITED STATES OF AMERICA  
AVAILABLE FROM:  
NATIONAL TECHNICAL INFORMATION SERVICE  
U.S. DEPARTMENT OF COMMERCE  
5285 PORT ROYAL ROAD  
SPRINGFIELD, VA 22161

NTIS PRICE CODES:  
PRINTED COPY: A05  
MICROFICHE COPY: A01

HN-00020-1098  
U.C. 66A

COLADO GEOTHERMAL RESOURCE ASSESSMENT  
FINAL REPORT

SHALLOW HOLE TEMPERATURE SURVEY  
INTERMEDIATE DEPTH HOLES IGH #1 AND #2  
DEPTH TEST HOLE 44X-10

NILE O. JONES

HOLMES & NARVER, INC.  
ENERGY SUPPORT DIVISION  
P.O. Box 14340  
LAS VEGAS, NV 89114-4340

PREPARED FOR:  
U.S. DEPARTMENT OF ENERGY  
NEVADA OPERATIONS OFFICE  
UNDER CONTRACT DE-AC08-76NV00020

## ABSTRACT

The Getty Oil Company began the field work on a government cost-sharing venture to assess the geothermal potential in the Colado area of Pershing County, Nevada. Eighteen shallow (500-foot) temperature gradient holes, two intermediate (1,500-foot) temperature gradient holes and one deep (8,000-foot) exploratory well were drilled. All field work was completed in May, 1981. Maximum temperature achieved was 282°F at 7,064 feet. No fluid reservoir was encountered with this hole.

TABLE OF CONTENTS

	<u>Page</u>
1. <u>INTRODUCTION</u> .....	4
a. Purpose and Background .....	4
b. Participation .....	4
c. Project Tasks .....	4
2. <u>PRECONTRACT WORK</u> .....	6
a. Geology .....	6
b. Geophysics .....	8
c. Temperature Profiles, RG-1 and RG-2 .....	8
3. <u>DRILLING SUMMARY</u> .....	11
a. Shallow Gradient Holes .....	11
b. USL-IGH #1 .....	11
c. USL-IGH #2 .....	27
d. USL-44X-10 .....	27

APPENDICES

A. Daily Drilling Reports (3) .....	A-1-1
B. Bit Records .....	B-1-1
C. Casing and Tubulars .....	C-1-1
D. Log Listings .....	D-1-1
E. Well Completion Notices .....	E-1-1
F. Drilling Costs, Well 44X-10 .....	F-1-1
G. Geophysical Maps .....	G-1-1

FIGURES

1. General Location Map .....	5
2. General Geology Map .....	7
3. Geophysical Anomalies .....	9
4. Temperature Profiles, RG-1 .....	10
5. Temperature Profiles, RG-2 .....	12

	<u>Page</u>
6. Colado Land Status and Drill Hole Location Map .....	13
7. Lithologic Symbol Explanation .....	14
7a- Temperature and Lithologic Logs (Shallow-hole Survey) .....	15-23
7r.	
8. Isotherms 500 Feet Below Surface .....	24
9. Hole Completion Status, USL-IGH #1 .....	25
10. Lithologic and Temperature Logs for IGH #1 .....	26
11. Hole Completion Status, USL-IGH #2 .....	28
12. Lithologic and Temperature Logs for IGH #2 .....	29
13. Drilling Progress Chart, USL-44X-10 .....	30
14. Hole Completion Status, USL-44X-10 .....	31
15. Depth and Deflection Profile, 44X-10 .....	33
16. Directional Survey, 44X-10 .....	34
17. Lithologic Log for USL-44X-10 .....	35
18. Temperature and Lithologic Logs for USL-44X-10 .....	36

## 1. INTRODUCTION

a. Purpose and Background. In October 1978, the Getty Oil Company entered into a cost-sharing contract with the Department of Energy, Nevada Operations Office, for geothermal reservoir assessment work in and around the Colado KGRA (Known Geothermal Resource Area) in Pershing County, Nevada (Figure 1). The contract work was designed to augment existing drilling and geophysical information with data from 18 shallow (500-foot) temperature gradient holes, two intermediate (1,500-foot) temperature gradient holes, and one deep (8,000-foot) exploratory hole.

This report synthesizes both the existing and new information regarding the geothermal resource in the Colado area. The commercial aspects of the Colado KGRA will not be addressed as they lie beyond the scope of this report.

b. Participation. The Colado KGRA Assessment Program was initiated by the award of Contract No. DE-AC08-79ET27008 to Getty Oil Company through the DOE Nevada Operations Office. Related geology field work was funded through the DOE Idaho Operations Office (ID) under Contract No. DE-AC07-80ID12079 with the University of Utah Research Institute (UURI). Geophysical surveys conducted by Lanton Surveys and Electrodyne Survey Services were funded by Getty Oil Company prior to initial DOE funding. Responsibility for drilling, logging, sampling, technical and administrative support was provided by Getty Oil Company. Cuttings, cores and fluid samples were delivered to UURI for storage in their Geothermal Sample Laboratory.

Detailed information and data from each of the wells drilled under these contracts are available through the University of Utah Research Institute, Earth Science Laboratory (UURI/ESL), 420 Chipeta Way, Suite 120, Salt Lake City, Utah 84108.

c. Project Tasks. Assessment of the geothermal reservoir potential at the Colado KGRA was to include:

LOCATION MAP, COLADO K.G.R.A., PERSHING CO., NEVADA  
NOT TO SCALE

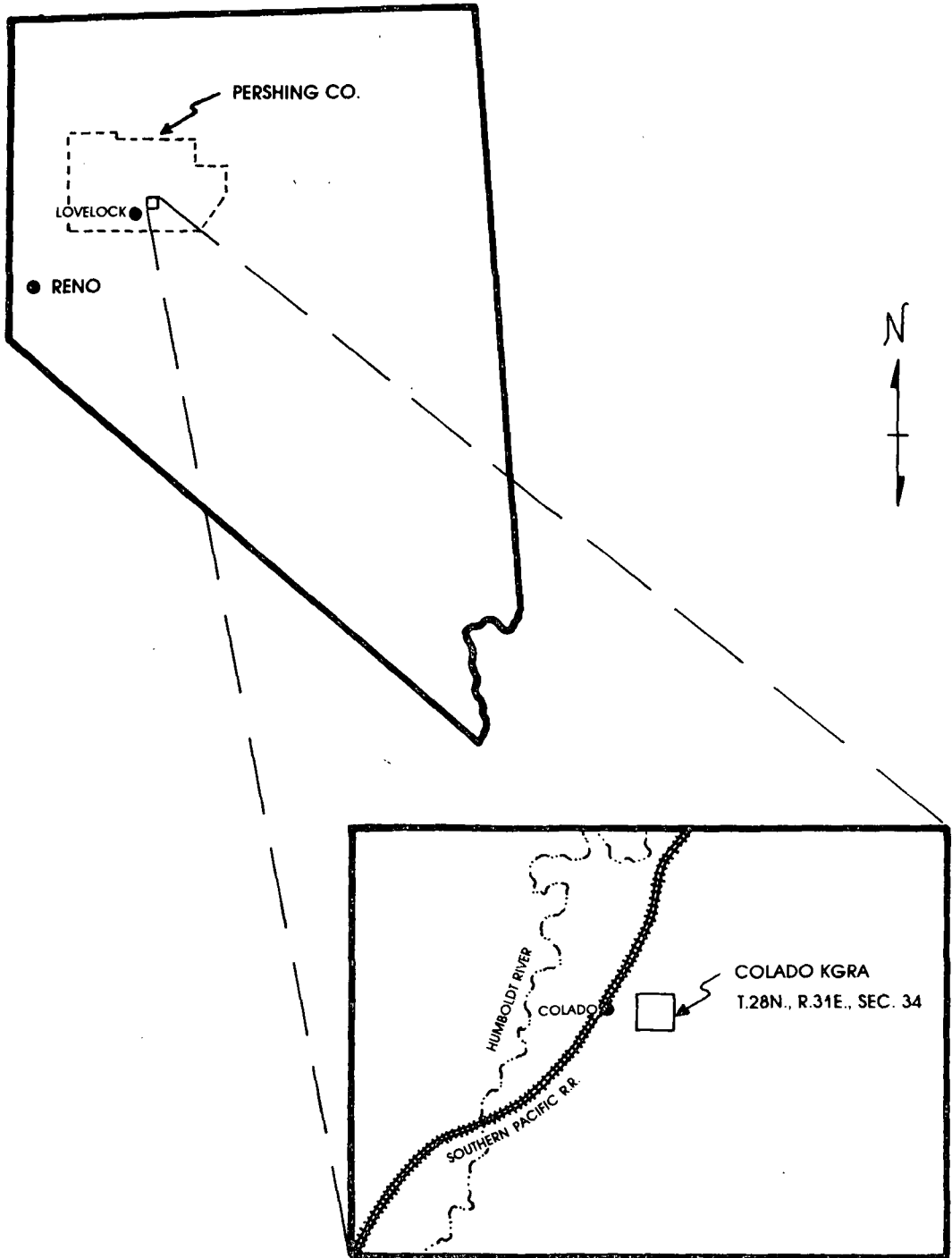

FIGURE 1



(1) Reexamination of existing geophysical and drilling data.

(2) Drilling and logging 18 new shallow (500-foot) and two intermediate (1,500-foot) temperature gradient holes.

(3) Construction of a surface geology map covering the resource area.

(4) Drilling and logging a deep (8,000-foot) exploratory well, and then evaluating the geothermal reservoir characteristics by conducting a 24- to 48-hour flow test, if well conditions permitted.

## 2. PRECONTRACT WORK

a. Geology. The Colado KGRA is located in southcentral Pershing County, Nevada (Figure 1). The eastern portion lies in the West Humboldt Mountain Range while the western part is in the Humboldt River Valley. Bedrock exposures consist mainly of Triassic to Jurassic sediments and meta-sediments that characterize the Auld Lang Syne Group. The impure Lovelock limestone (Jr) overlies the Auld Lang Syne Group in the southern portions of the range, but erosion has removed much of it and a subsequent diorite extrusive from the area. These units have been combined into one for purposes of presentation on the general geology map (Figure 2).

The Tertiary rocks in the West Humboldt Range occur as unconformable, isolated erosional remnants of volcanics and sediments. No Tertiary rocks have been encountered in the drill holes spudded in the valley alluvium.

Quaternary sediments consist of lacustrine deposits of ancestral Lake Lahontan and the more recent alluvium deposited by the Humboldt River.

Faulting has been extensive and recurrent. High-angle faults trend north, northwest and northeast while low-angle faults generally dip west. Horst-graben structures are common along reactivated northeast and northwest

# GENERAL GEOLOGY OF THE COLADO AREA, PERSHING COUNTY, NEVADA

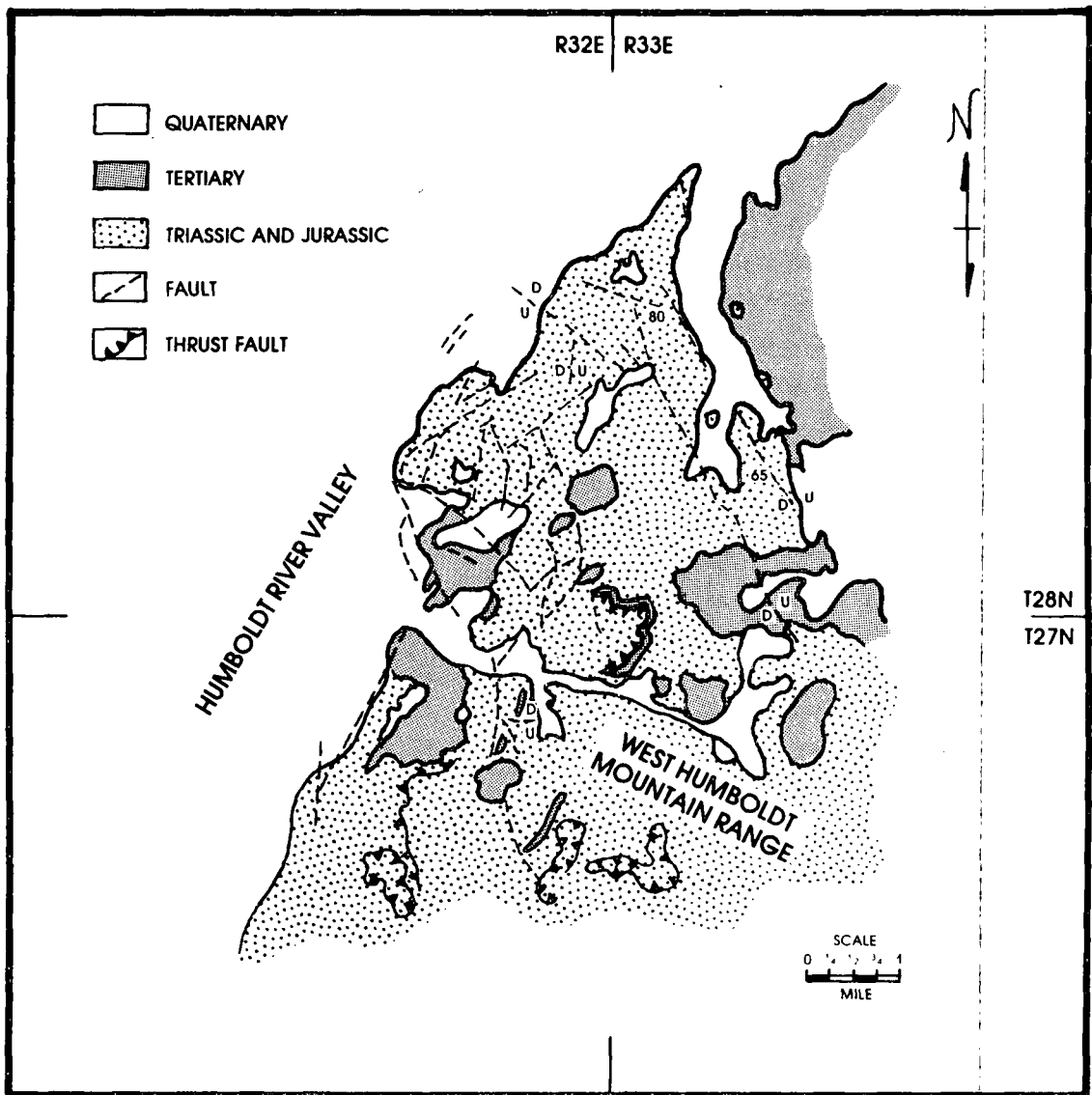

FIGURE 2

structural pairs. Graben displacement is on the order of tens to a few hundreds of feet. Faults often horsetail, form fracture zones or become breccia zones. Some of the low-angle faults in the southern portion of the area have been interpreted as thrust faults.

b. Geophysics. Geophysical reconnaissance surveys measuring electrical resistivity, gravity and magnetic properties were run over approximately 100 square miles in the Colado, Nevada area during July 1977. Follow-up detail surveys were performed in areas considered most favorable for near-surface geothermal reservoirs in October and November. Appendix G lists the geophysical maps of the area. Electrodyne Surveys of Sparks, Nevada was primarily responsible for the surveys and subsequent data reduction.

Six probable geothermal zones were outlined using acceptable structural and electrical parametric indicators (Figure 3). Five of the anomalies are in the graben block that makes up the bedrock margin. The sixth underlies the exposed bedrock and generally conforms to the exposed fault patterns. The basinward geothermal anomalies appear to lie from 4,000 to 6,000 feet below the valley floor and in zones from 1,500 to 3,000 feet thick.

c. Temperature Profiles, RG-1 and RG-2. Two mineral holes were drilled to a depth of about 450 feet on Getty Oil Company-held property during August 1976. Figure 4 graphs the temperature measurements taken for RG-1 on the 17th and 19th of the month. The following notes on RG-1 were made during that time:

8/17/76. Wells drilled with Air. Hit Lgt. flow of steam vapor and heated warm water at 400 feet. At 425 feet, Estimated 5-7 (**gal/min?**) 5:00 p.m., water entry with hole caving. Flow increased to 10-15 (**gal/min?**) 6:00 p.m. estimated at 445 feet. No further penetration due to hole caving.

8/19/76. Hole may be bridged over and giving a false reading as to depth. The Thermistor line simple (**simply?**) spools off and is difficult to check bottom hole depth measurements.

# GEOPHYSICAL ANOMOLIES

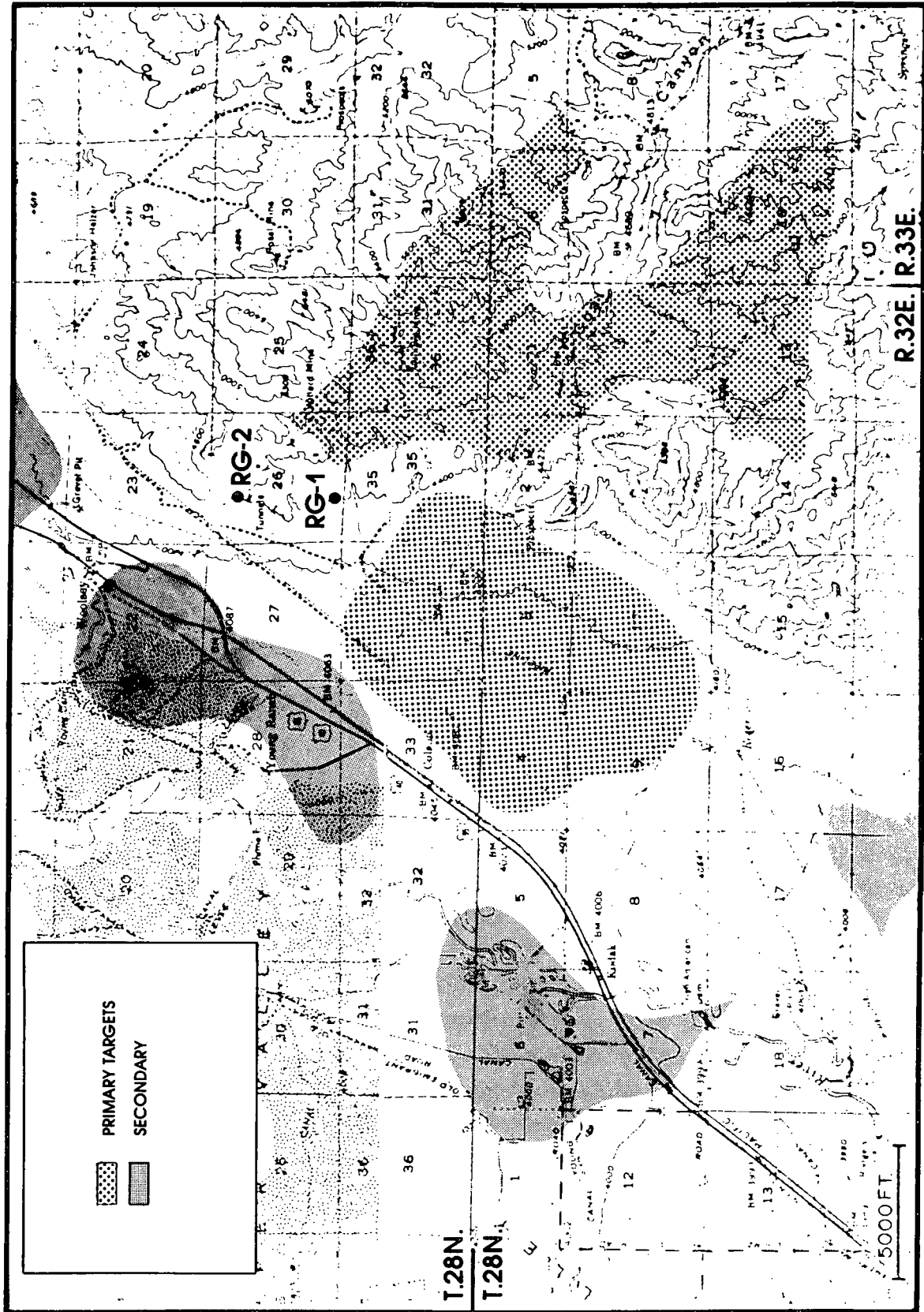

FIGURE 3

# TEMPERATURE PROFILES, RG-1

T.28N., R.32E., SEC. 26 cdc

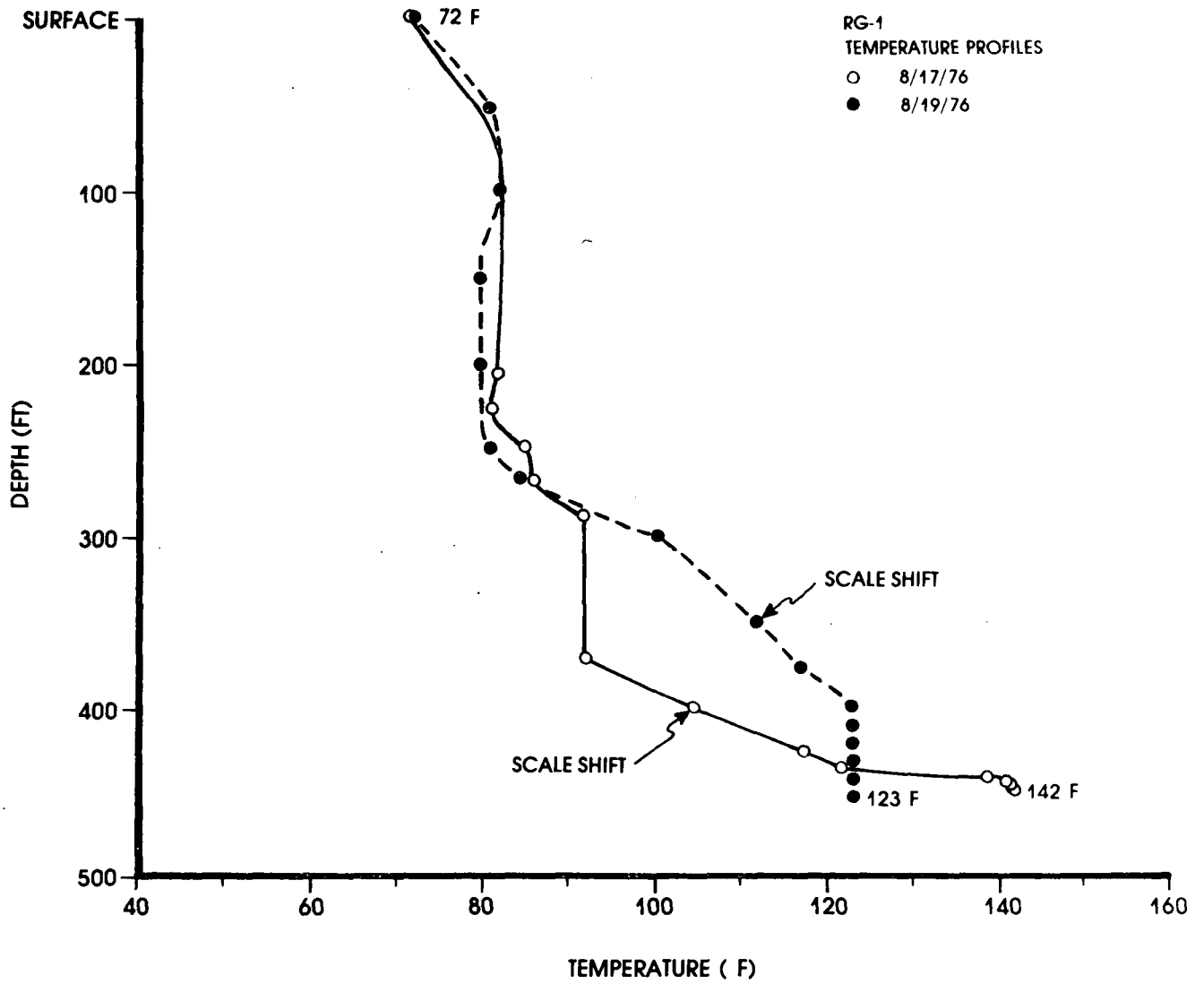

FIGURE 4

Figure 5 graphs the temperature measurements of RG-2. The notes on RG-2 are much briefer:

8/19/76. Hole caving with fluid entry on bottom.

8/20/76. Hole may be bridged or caved in above indicated depth of 450 feet estimated total depth.

The higher temperatures recorded in RG-2 may be due to its more favorable location along with the central trend of the bedrock anomaly.

### 3. DRILLING SUMMARY

a. Shallow Gradient Holes. Electrodyne Surveys proposed a shallow-hole temperature gradient survey of the Getty holdings. During the first quarter of 1979, 18 holes were drilled to an average depth of about 500 feet. Figure 6 shows the location of these holes in relation to the Getty Oil Company land holdings at that time. The 1978 DOE/NV Contract with Getty Oil Company partially funded this shallow-hole survey as well as subsequent work described in Sections b, c and d of this Chapter. Figure 7a through 7r are comparisons of temperature and rock type for each well in the shall-hole survey. Figure 8 is an isotherm map of values recorded to 500 feet.

b. USL-IGH #1. During the first week of March 1980, K. O. Bert Drilling Co. Inc., moved a rig onto the IGH #1 location in Section 26 of T.28N., R.32E. The hole was completed to a total depth of 1,501 feet by midmonth. A summary of daily drill reports is given in Appendix A. Figure 9 shows the completion status at that time.

The well was allowed to reach thermal equilibrium. Temperature logs were run on May 6, 1980. Lithology and temperature profile for IGH #1 is shown in Figure 10. Maximum temperature of 215.7°F was recorded at 415 feet. Bottom-hole temperature was 159.3°F. A list of logs and logging dates for IGH #1 is given in Appendix D.

# TEMPERATURE PROFILES, RG-2

T.28N., R.32E., SEC. 26 bad

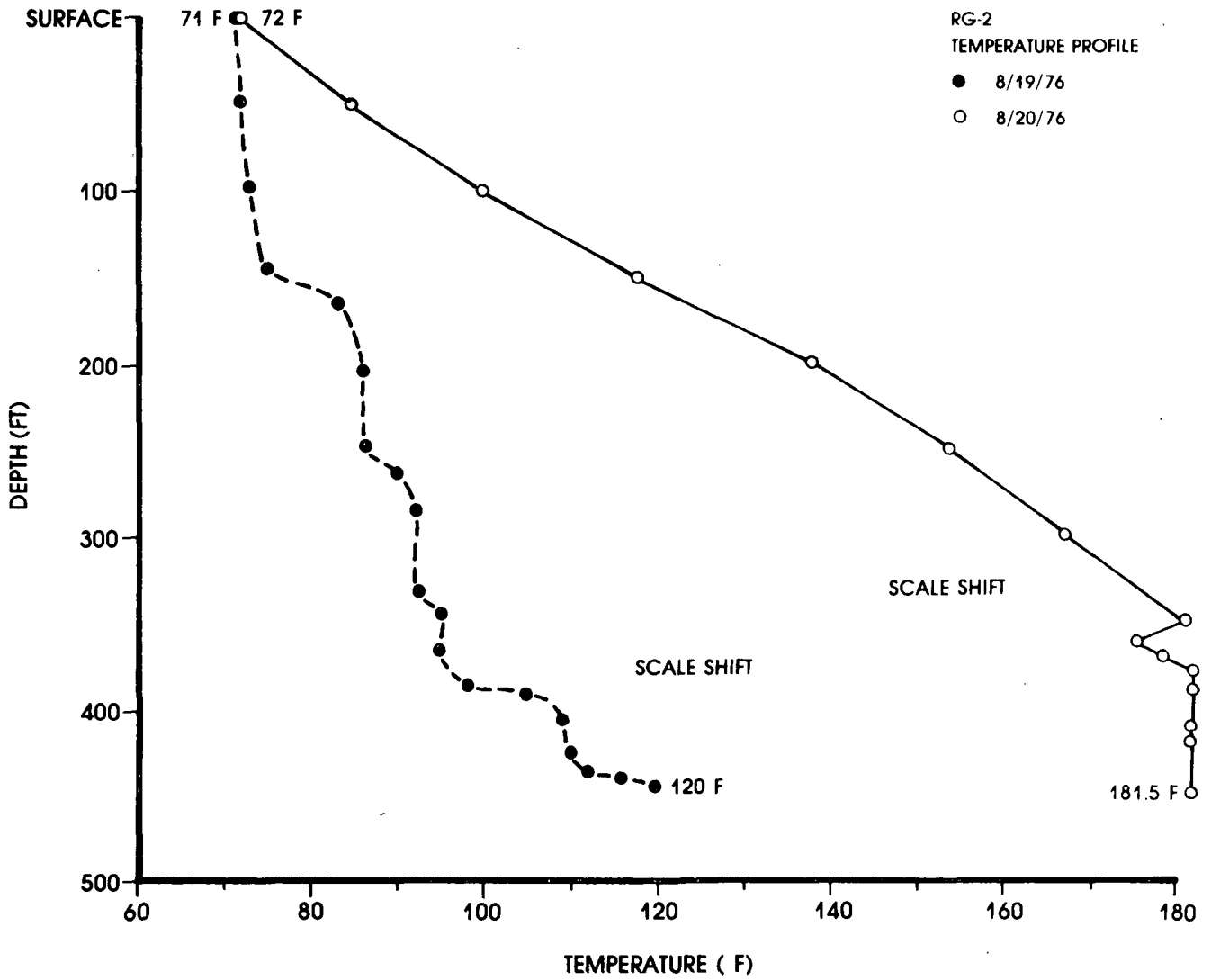
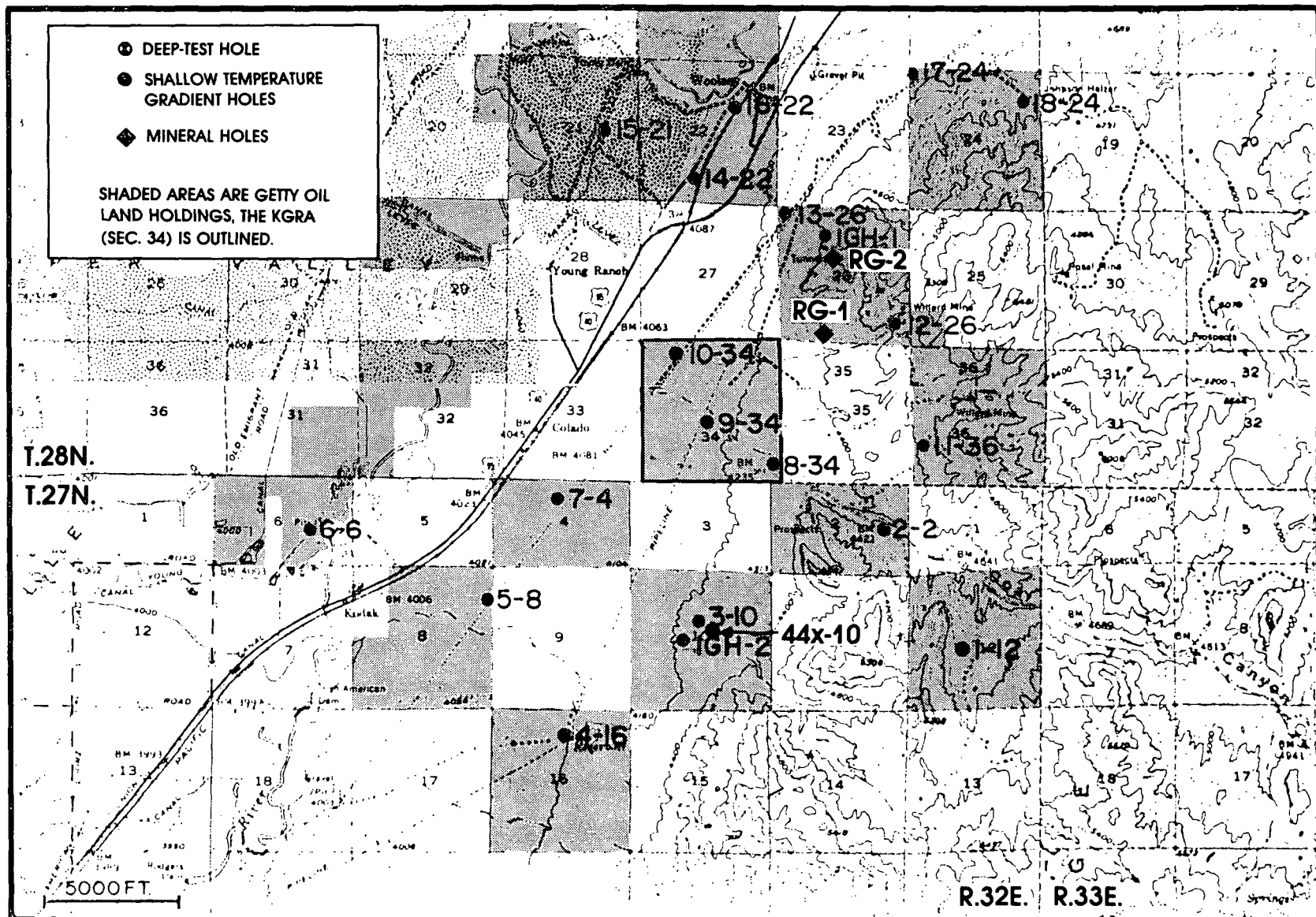

FIGURE 5

# COLADO LAND STATUS AND DRILL HOLE LOCATION MAP



13

FIGURE 6



# EXPLANATION

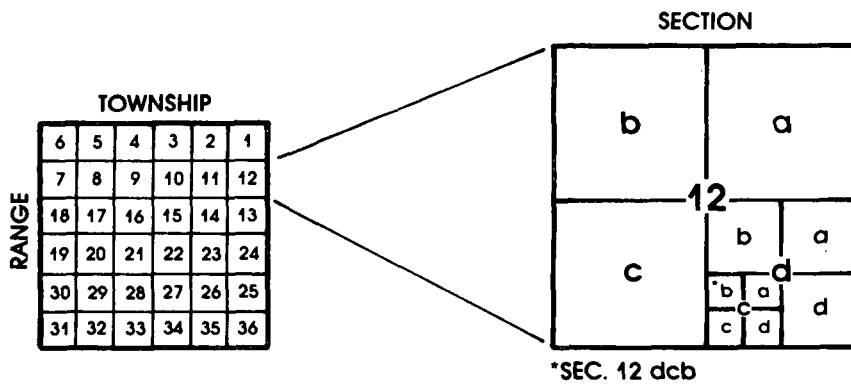
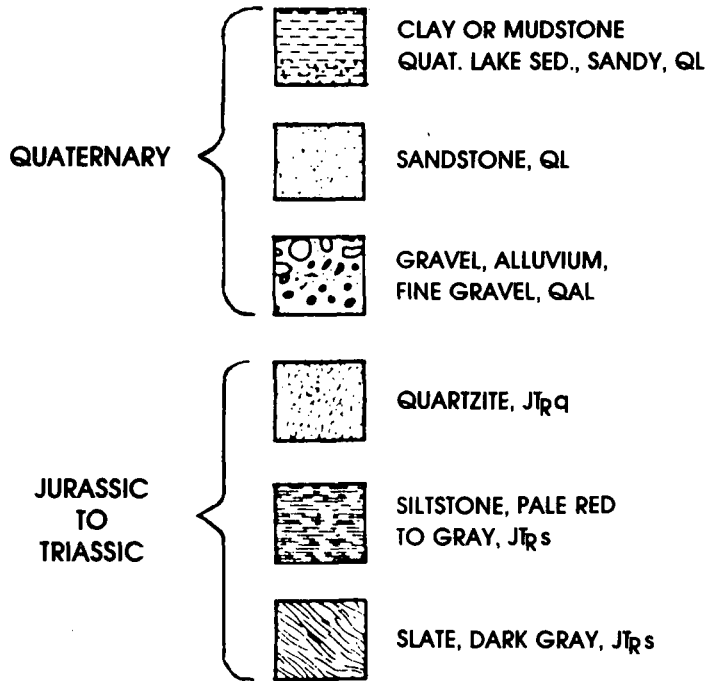

FIGURE 7

# TEMPERATURE AND LITHOLOGIC LOGS FOR COLADO 15-21

T.28N., R.32E., SEC. 21 dba

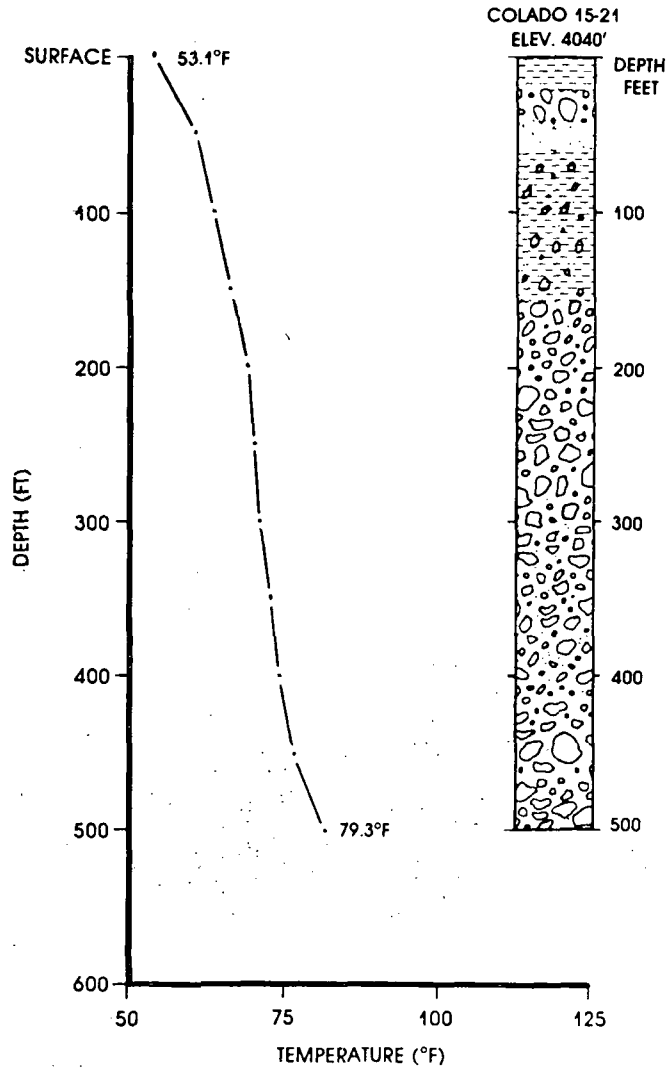

FIGURE 7a

# TEMPERATURE AND LITHOLOGIC LOGS FOR COLADO 16-22

T.28N., R.32E., SEC. 22 aca

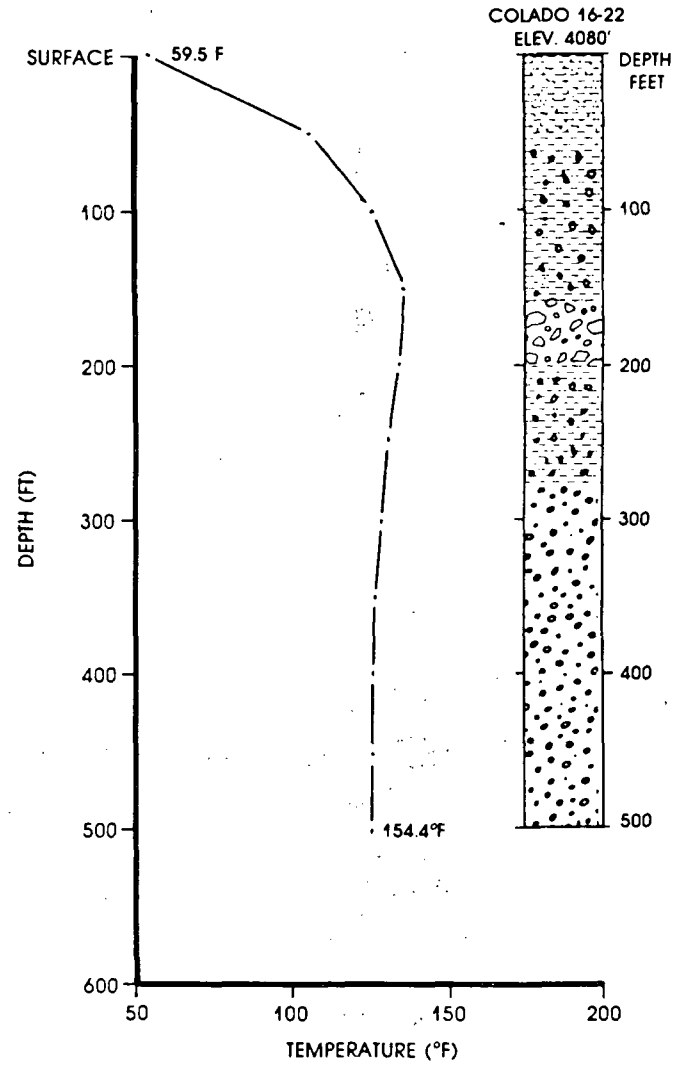

FIGURE 7b

### TEMPERATURE AND LITHOLOGIC LOGS FOR COLADO 14-22

T.28N., R.32E., SEC. 22 cda

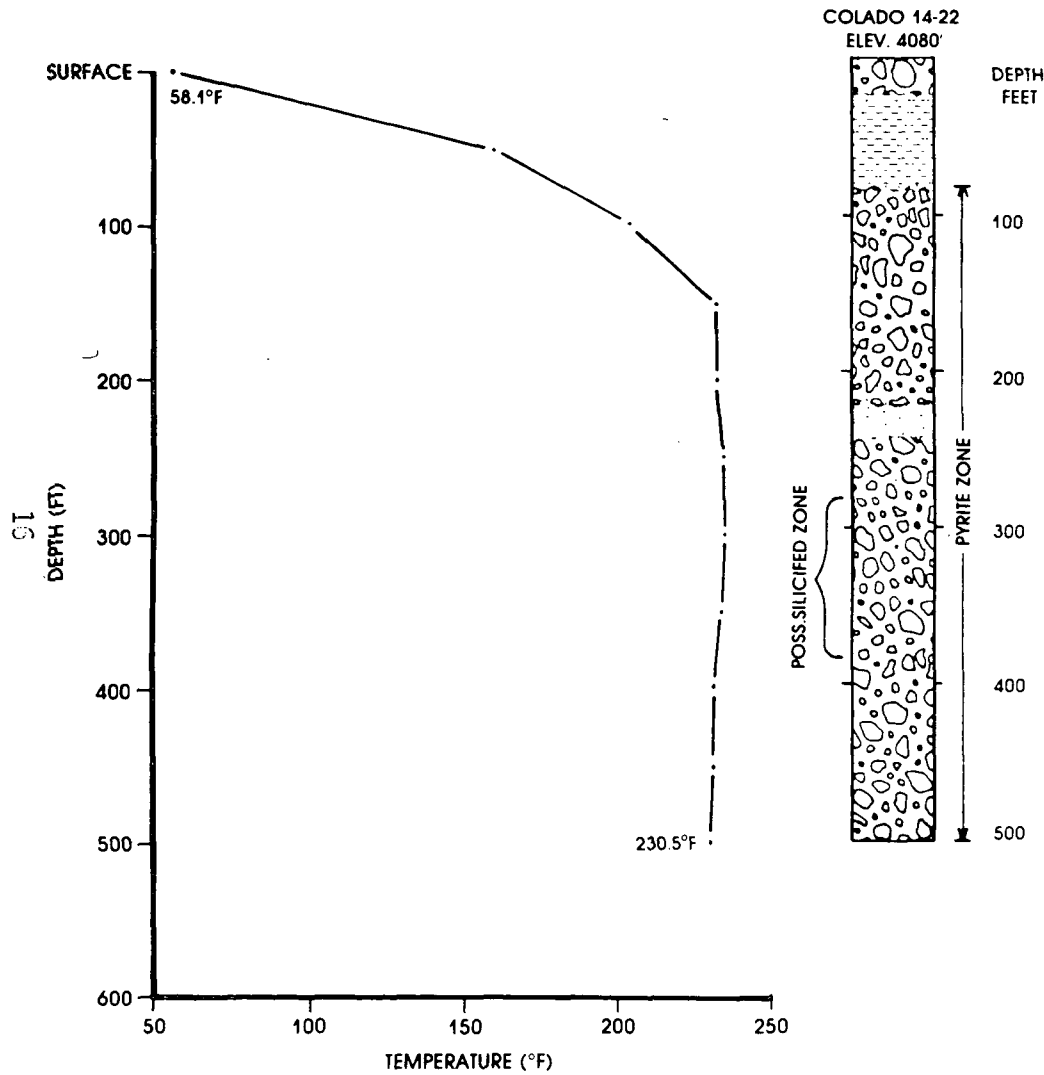

FIGURE 7c

### TEMPERATURE AND LITHOLOGIC LOGS FOR COLADO 18-24

T.28N., R.32E., SEC. 24 adc

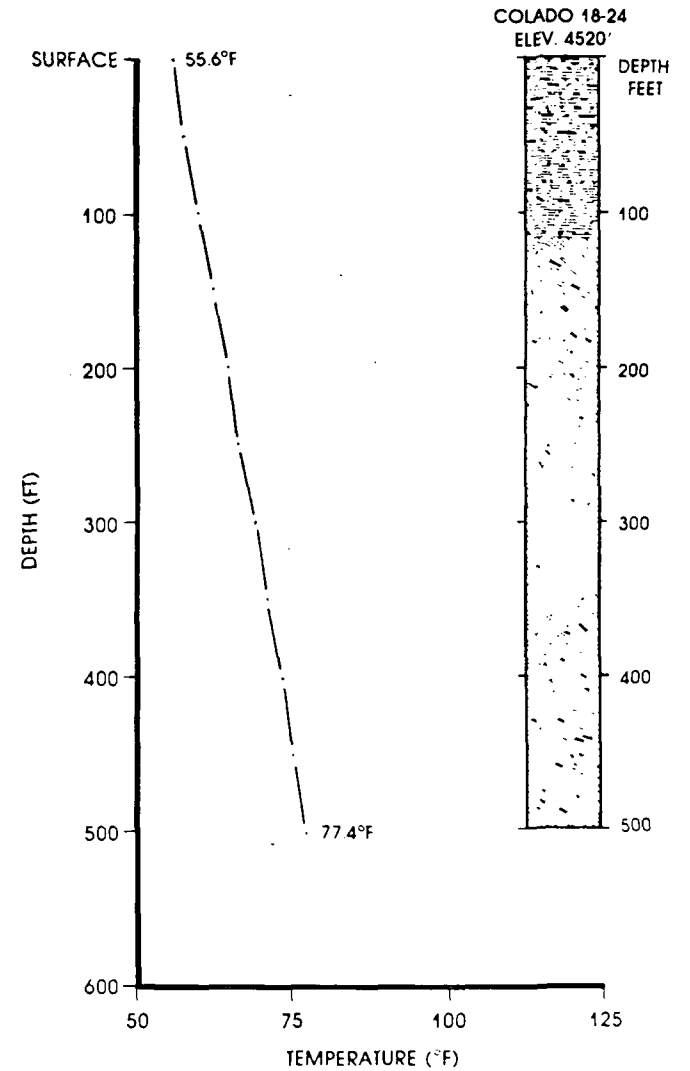

FIGURE 7d

TEMPERATURE AND LITHOLOGIC LOGS FOR  
**COLADO 17-24**  
 T.28N., R.32E., SEC. 24 bbb

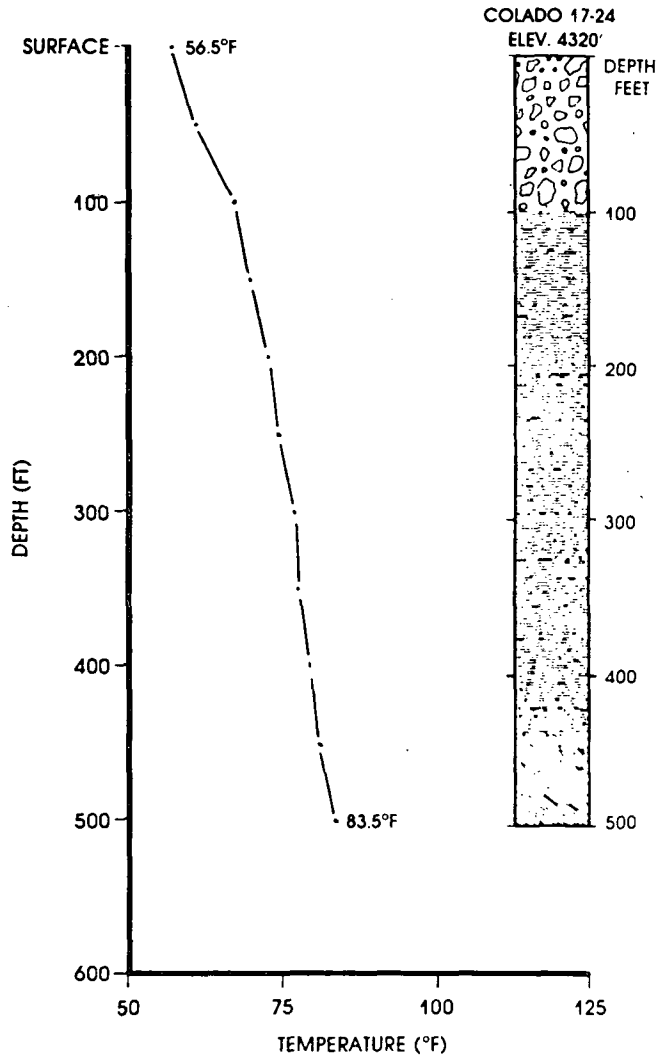

FIGURE 7e

TEMPERATURE AND LITHOLOGIC LOGS FOR  
**COLADO 13-26**  
 T.28N., R.32E., SEC. 26 bbb

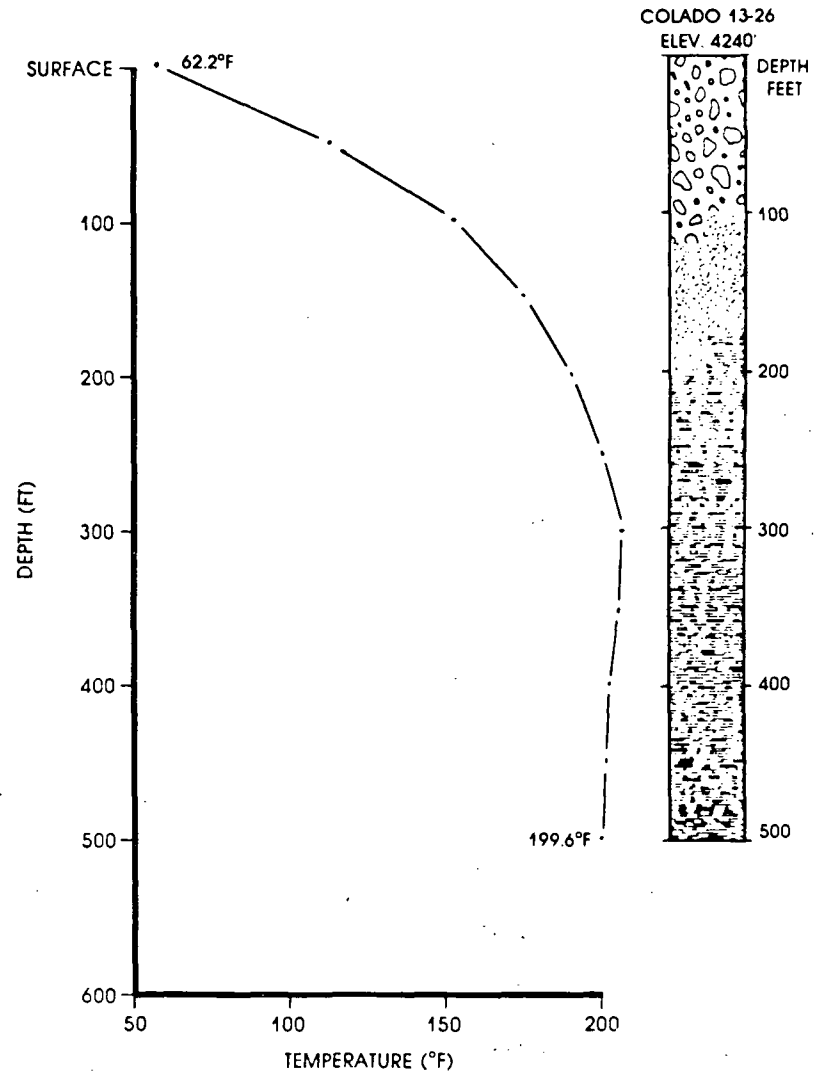

FIGURE 7f

### TEMPERATURE AND LITHOLOGIC LOGS FOR COLADO 12-26 T.28N., R.32E., SEC. 26 dda

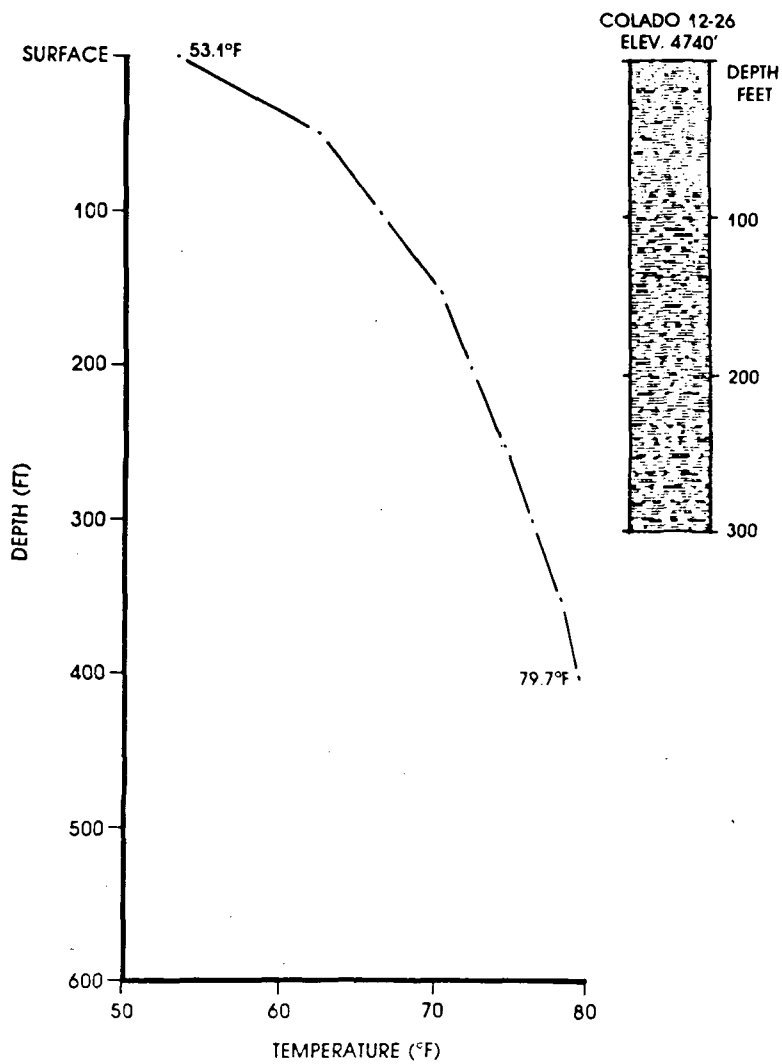

FIGURE 7g

### TEMPERATURE AND LITHOLOGIC LOGS FOR COLADO 10-34 T.28N., R.32E., SEC. 34 bab

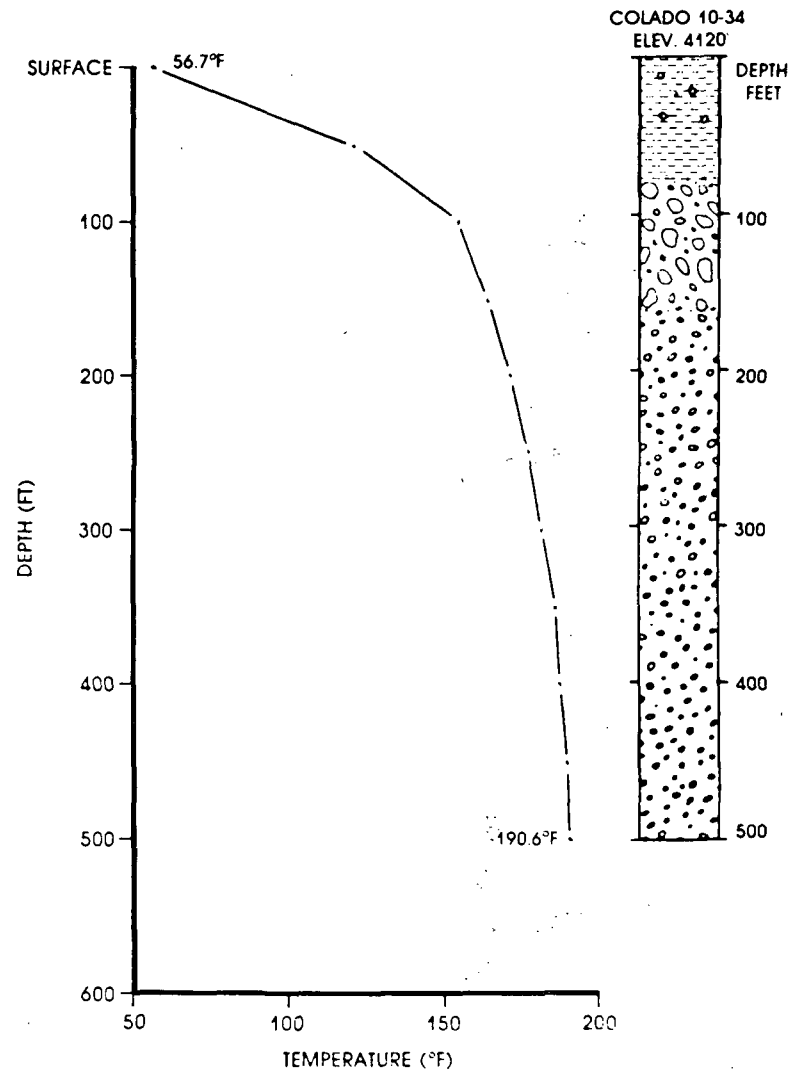

FIGURE 7h

### TEMPERATURE AND LITHOLOGIC LOGS FOR COLADO 9-34

T.28N., R.32E., SEC. 34 cca

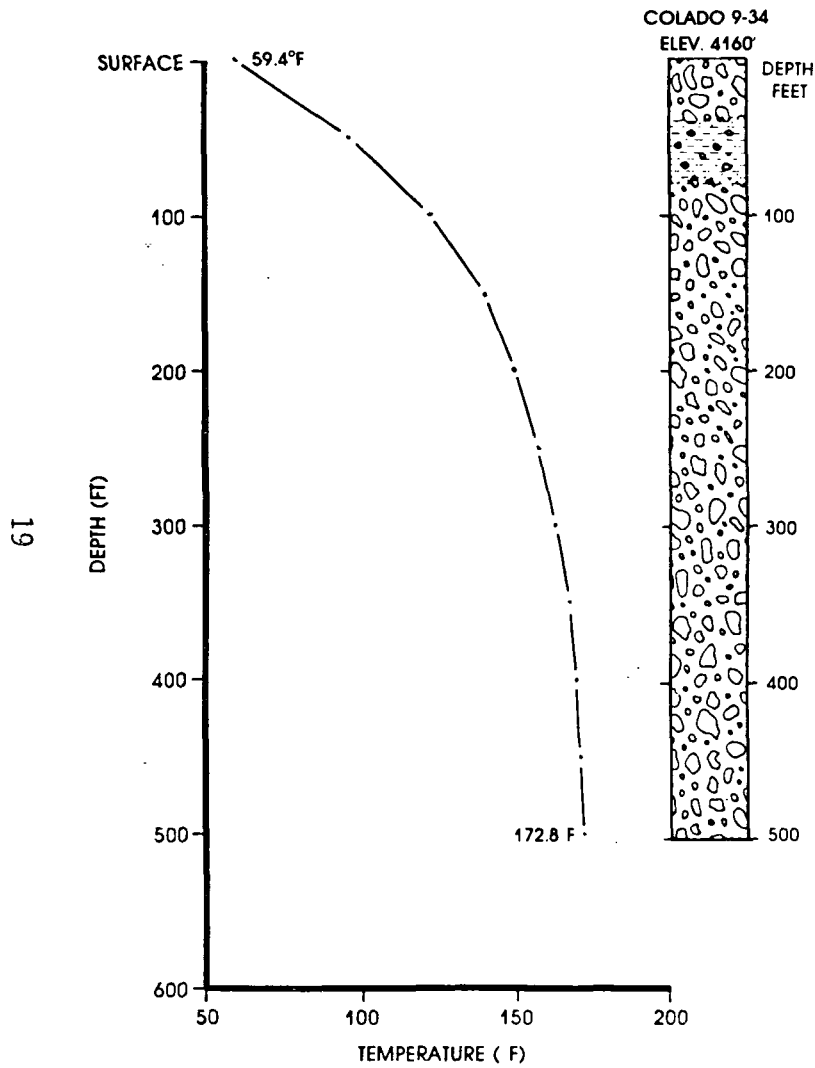

FIGURE 7i

### TEMPERATURE AND LITHOLOGIC LOGS FOR COLADO 8-34

T.28N., R.32E., SEC. 34 ddd

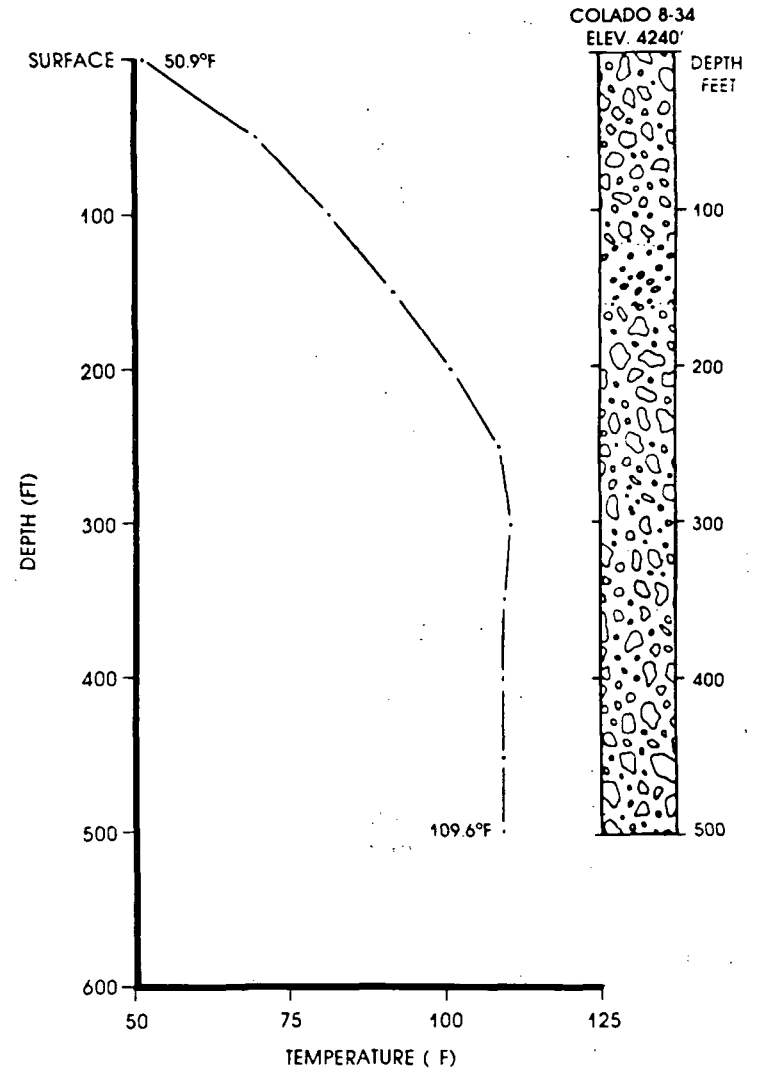

FIGURE 7j

### TEMPERATURE AND LITHOLOGIC LOGS FOR COLADO 11-36

T.28N., R.32E., SEC. 36 cbd

COLADO 11-36  
ELEV. 4700'

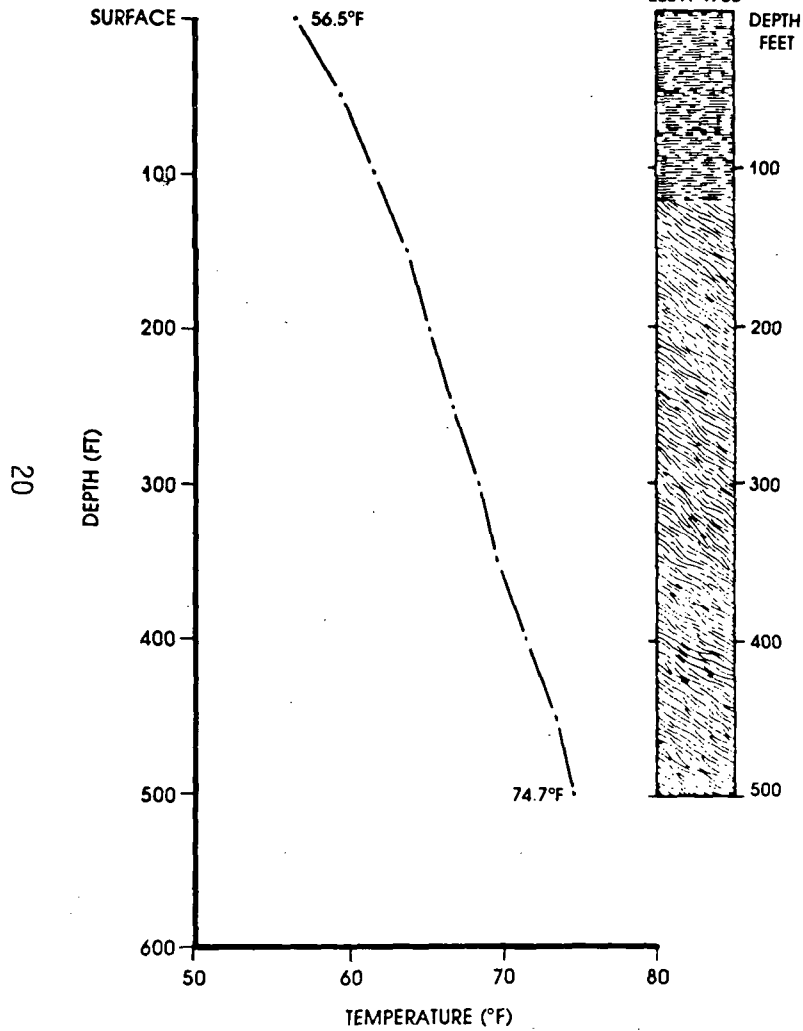

FIGURE 7k

### TEMPERATURE AND LITHOLOGIC LOGS FOR COLADO 2-2

T.27N., R.32E., SEC. 2 dab

COLADO 2-2  
ELEV. 4420'

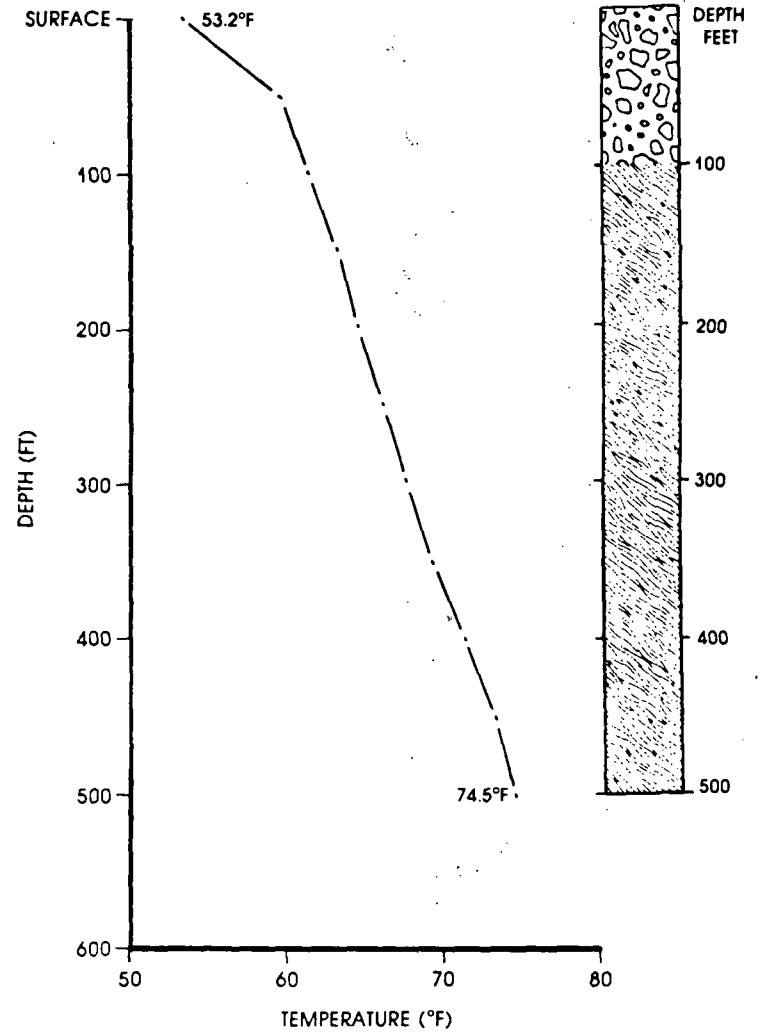

FIGURE 7l

# TEMPERATURE AND LITHOLOGIC LOGS FOR COLADO 7-4

T.27N., R.32E., SEC. 4 bad

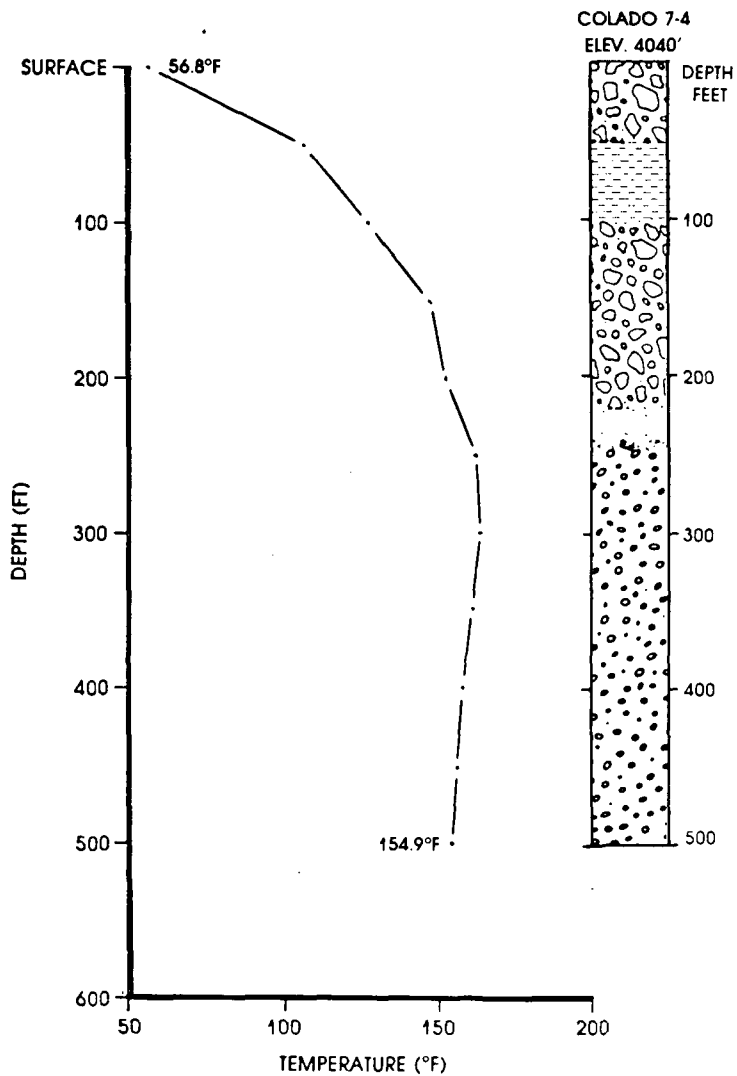

FIGURE 7m

# TEMPERATURE AND LITHOLOGIC LOGS FOR COLADO 6-6

T.27N., R.32E., SEC. 6 dba

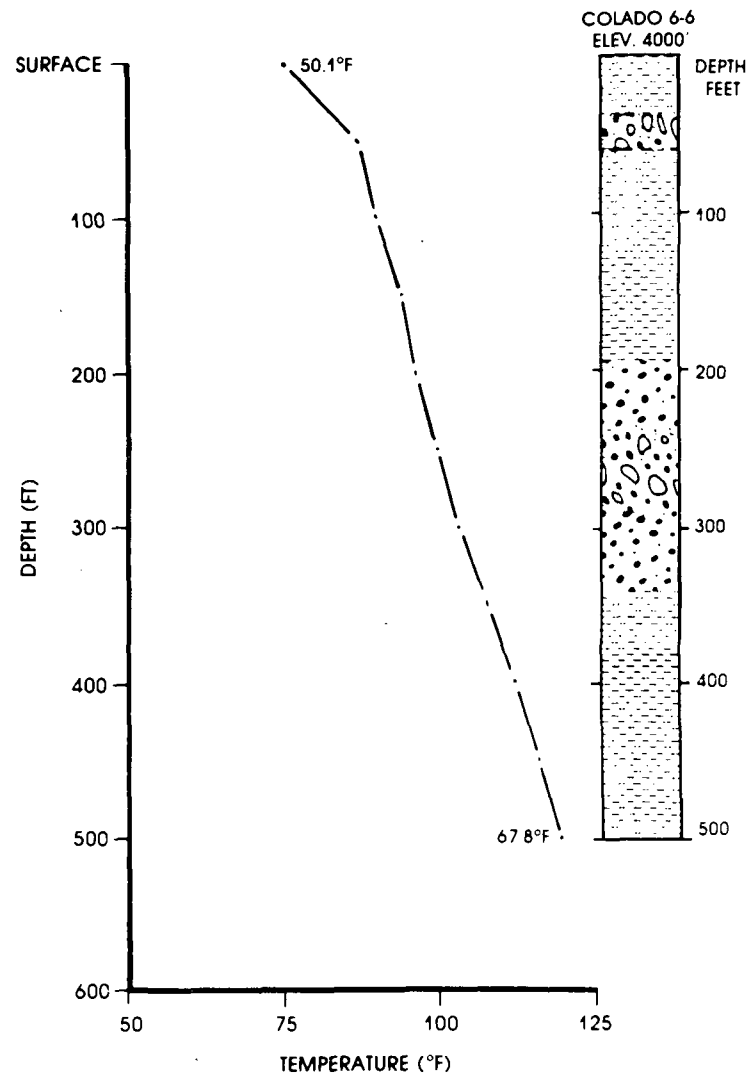

FIGURE 7n



# TEMPERATURE AND LITHOLOGIC LOGS FOR COLADO 5-8

T.27N., R.32E., SEC. 8 aad

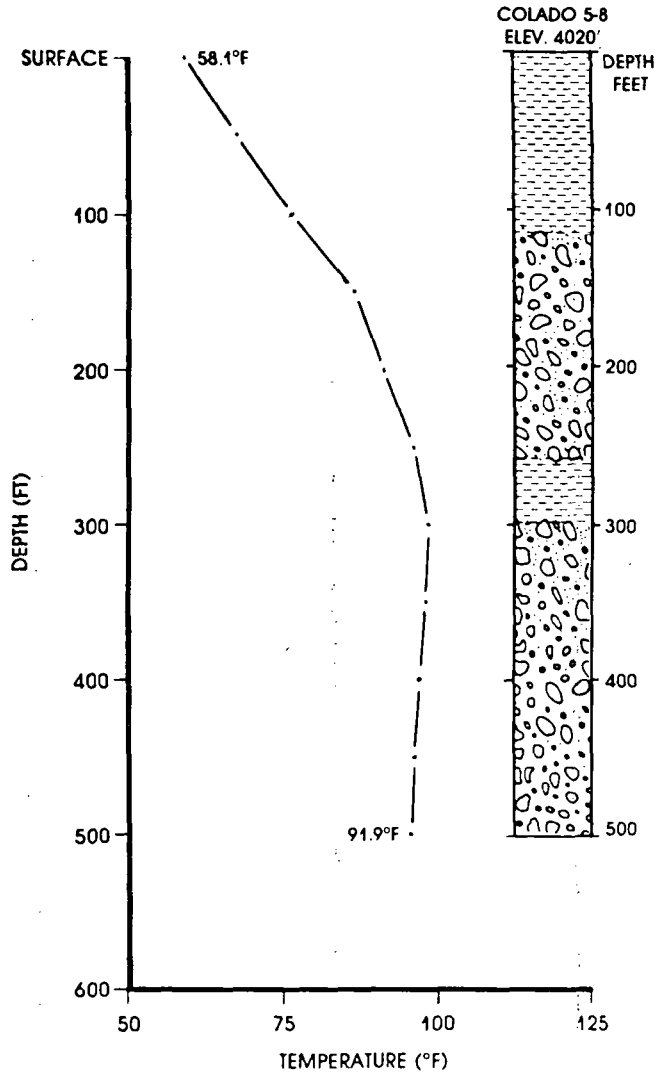

FIGURE 7o

# TEMPERATURE AND LITHOLOGIC LOGS FOR COLADO 3-10

T.27N., R.32E., SEC. 10 bdd

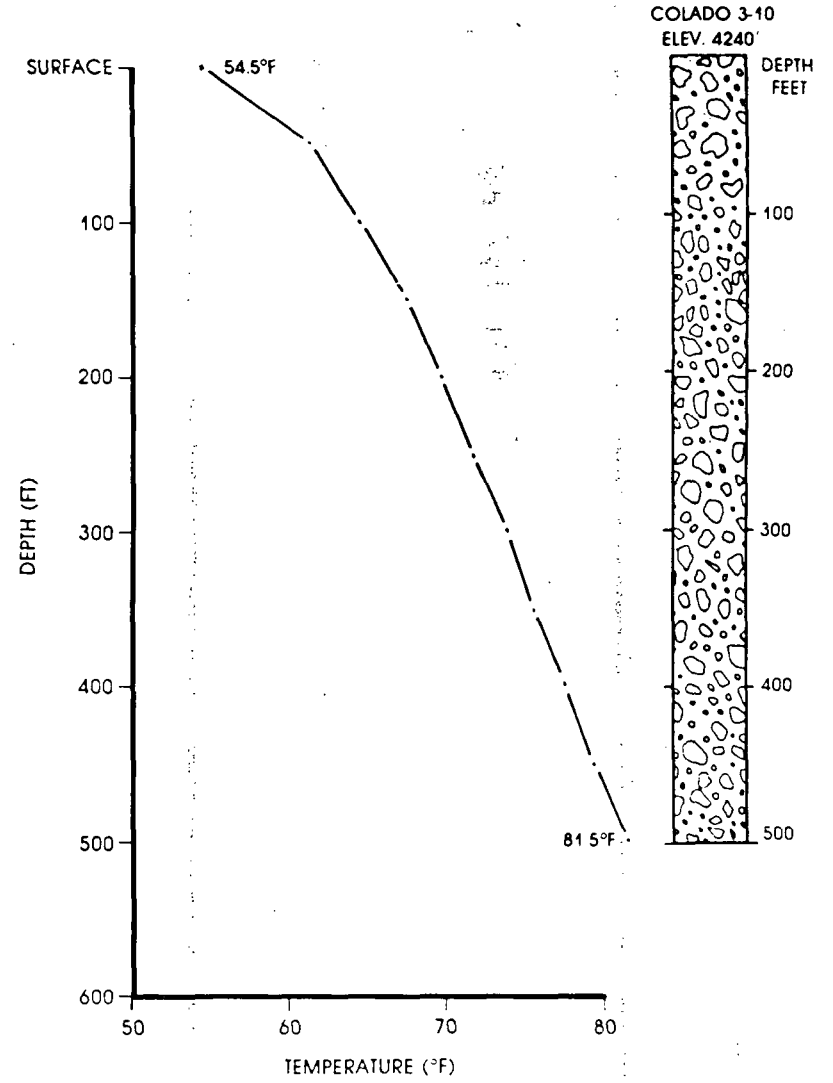

FIGURE 7p

# TEMPERATURE AND LITHOLOGIC LOGS FOR COLADO 1-12

T.27N., R.32E., SEC. 12 caa

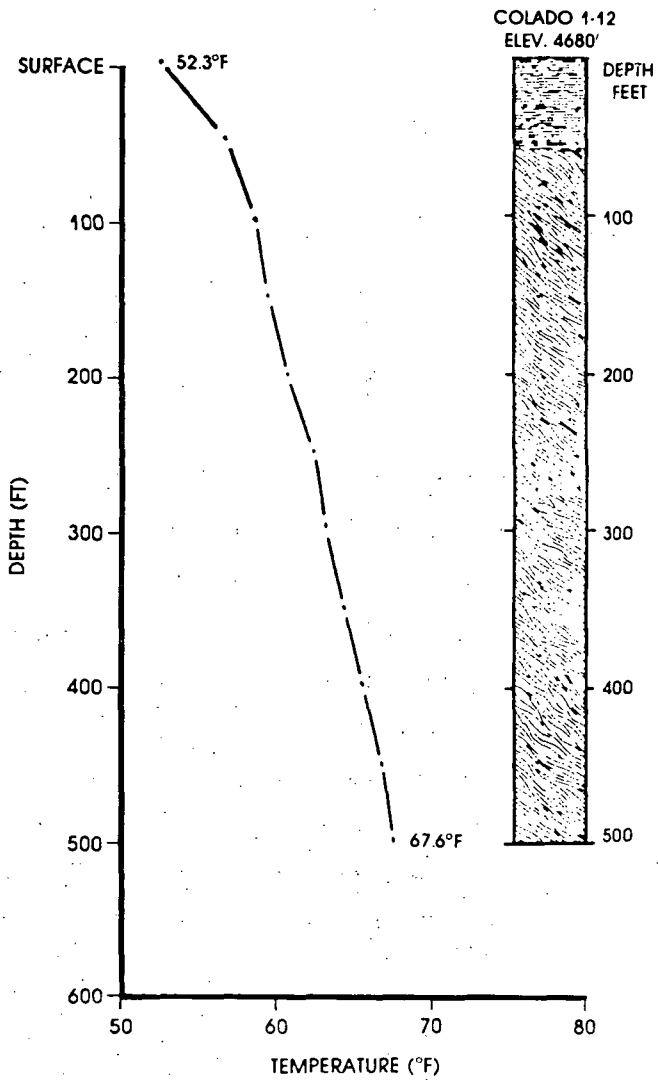

FIGURE 7q

# TEMPERATURE AND LITHOLOGIC LOGS FOR COLADO 4-16

T.27N., R.32E., SEC. 16 abc

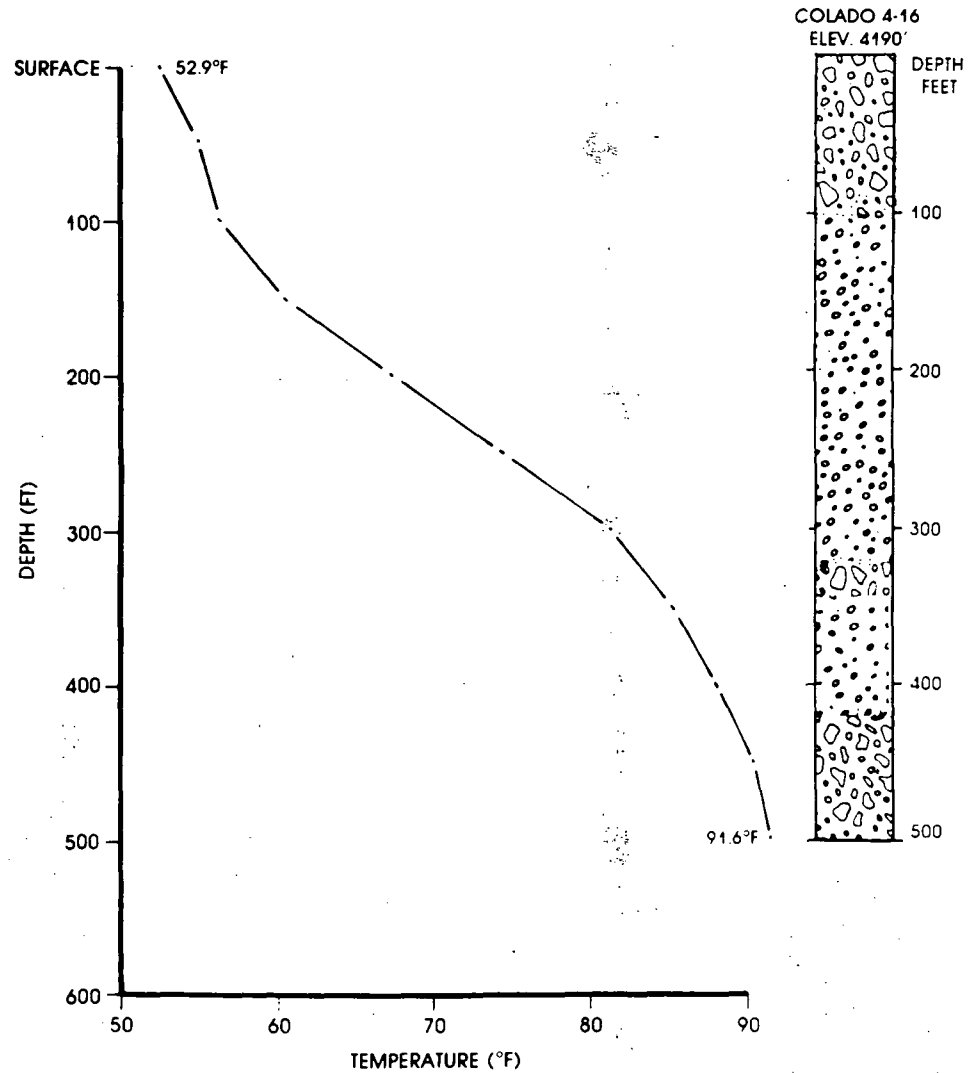
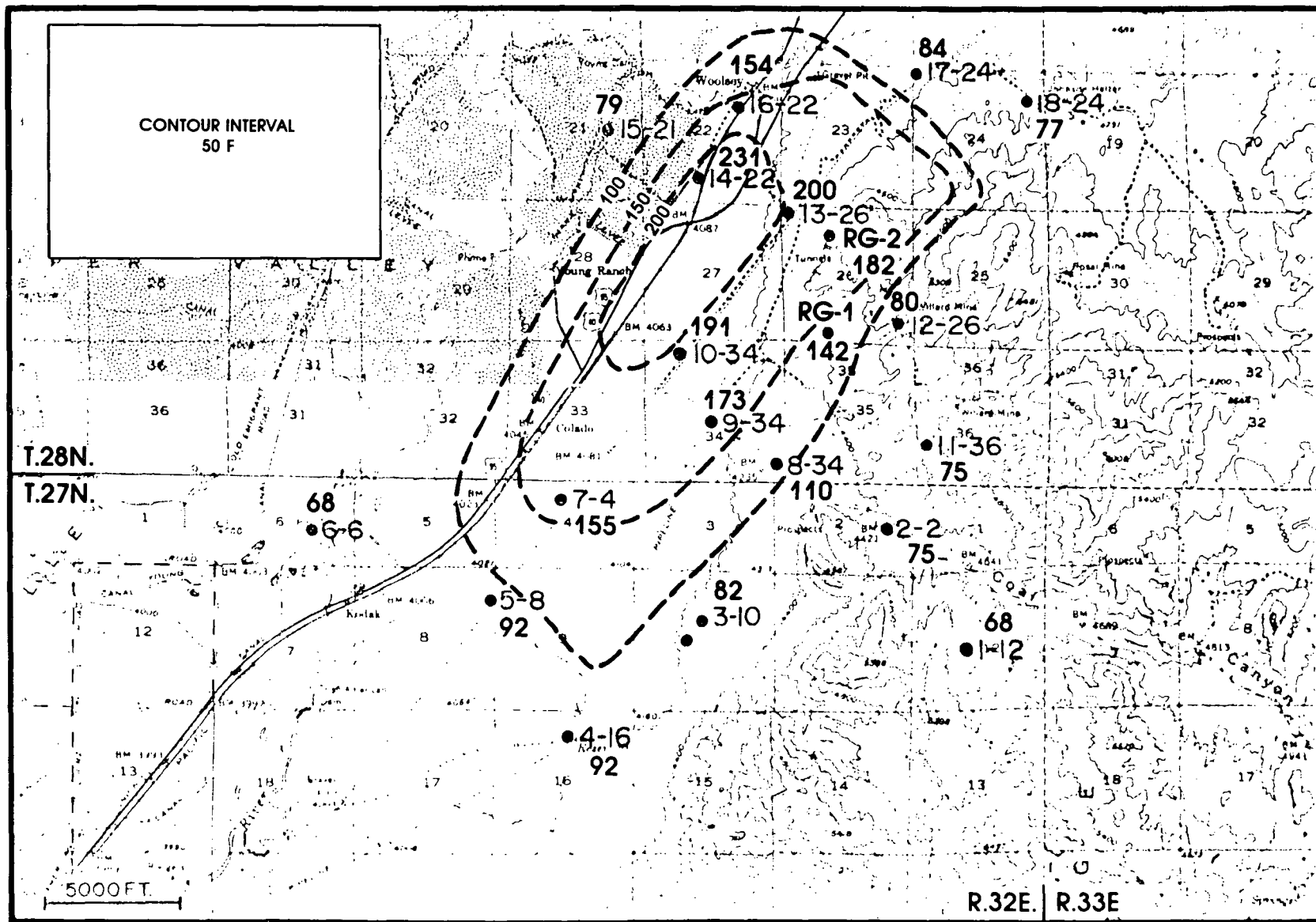

FIGURE 7r

# ISOTHERMS 500 FT. BELOW SURFACE IN THE COLADO AREA, PERSHING CO., NEVADA



24

FIGURE 8

# HOLE COMPLETION STATUS IGH #1

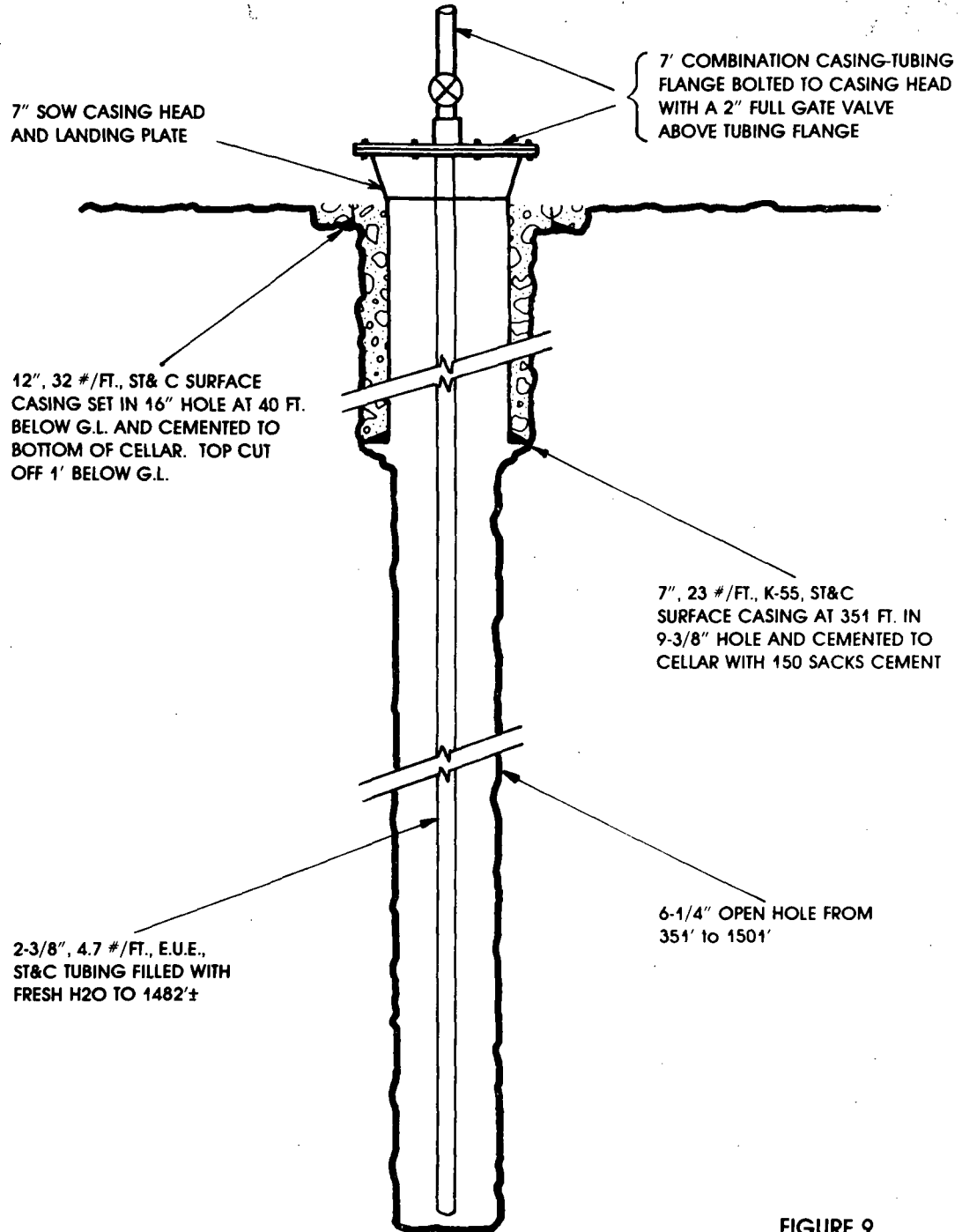

FIGURE 9

# LITHOLOGIC AND TEMPERATURE LOGS FOR IGH-1

T.28N., R.32E., SEC. 26 bac

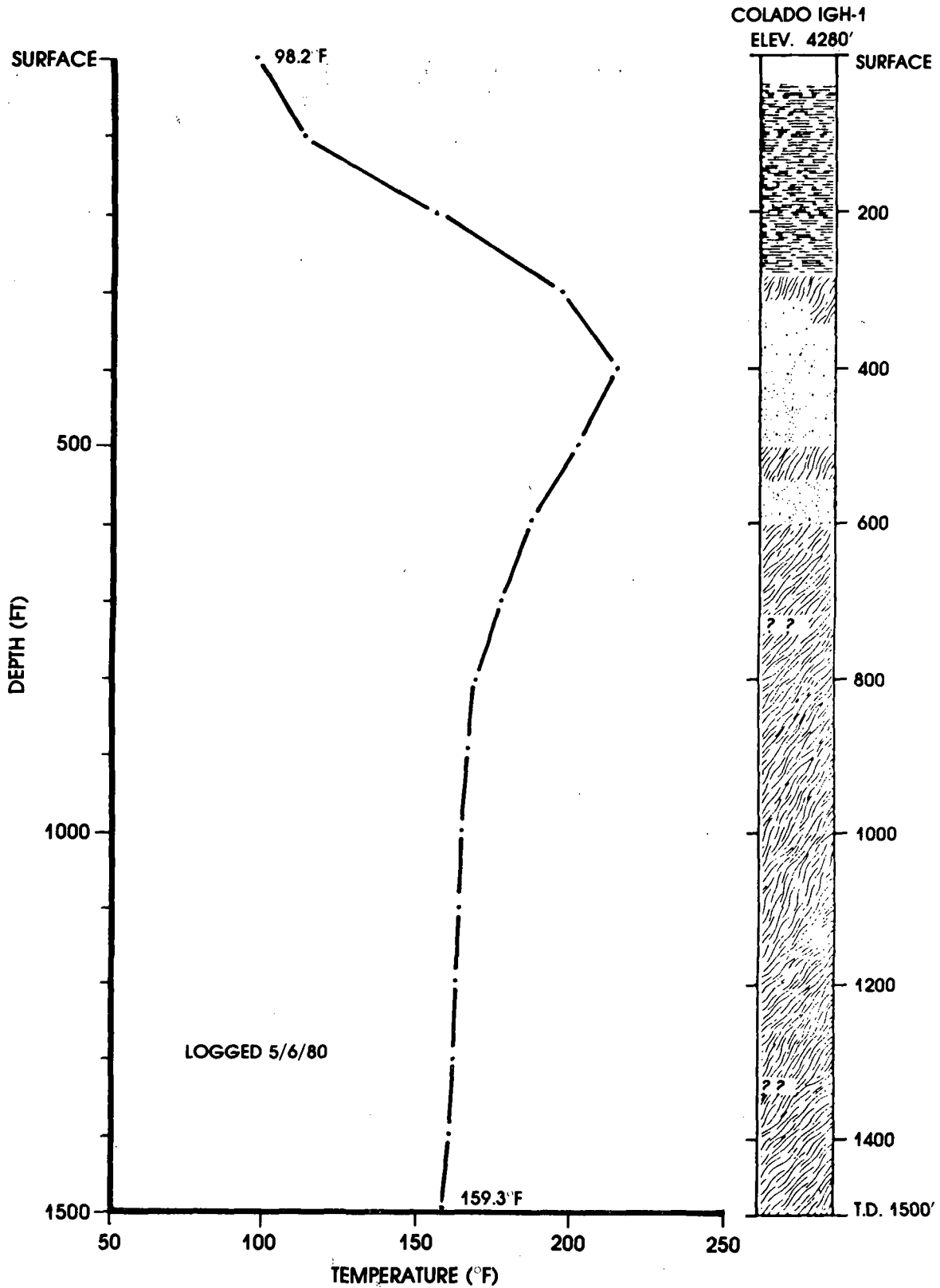

FIGURE 10

c. USL-IGH #2. Southwest Drilling and Exploration Inc., drilled IGH #2, located in Section 10, T.27N., R.32E. They rigged up on October 29, 1979, and were released on the 18th of the following month. The open hole was logged to depth of 1,164 feet on the 17th, but the temperature logs were delayed in order for the hole to reach thermal equilibrium.

A summary of daily drill reports are given in Appendix A, the rotary bit record in Appendix B, and Appendix D lists the logs and run dates. Figure 11 shows the completion status of IGH #2, while the lithology and three temperature profiles are shown in Figure 12.

d. USL-44X-10. All data gathered prior to 1981 was reviewed and a site was selected for a large diameter deep-test hole (T.27N., R.32E., Sec. 10 bdd). Brinkerhoff-Signal Drilling Company spudded on March 13, 1981. Conventional rotary drilling techniques were used to achieve total depth. Mud weights were kept in the range of 65-70 pcf and viscosity maintained at about 35 seconds. The 17 1/2-inch surface hole was drilled to 1,215 feet in four days. A 13 3/8-inch, 54.5 pound/foot casing string was set to 1,213 feet and cemented to the surface.

Blow out prevention equipment (BOPE) was installed and tested to 1,000 psi on March 18, 1981. Drilling continued using 12 1/4-inch mill tooth- and insert-design roller bits. Bit records for 44X-10 are in Appendix B. The 12 1/4-inch hole was reduced to 8 1/2 inches at 5,977 feet. Reduction occurred on April 18, 1981. Total depth of 7,964 feet was reached on May 4, 1981, and logs were run the following day. The hole was cleaned out on the 6th and left filled with clean water. Rig release came on May 8, 1981, following installation of the wellhead equipment.

No significant drilling problems or abnormal delays occurred during this phase of the project. A detail drilling summary is given in Appendix A and a drilling progress chart is presented in Figure 13. Figure 14 shows the hole completion status for this hole. Appendix C is a listing of casings and tubulars used and Appendix E contains the completion notices.

# HOLE COMPLETION STATUS IGH #2

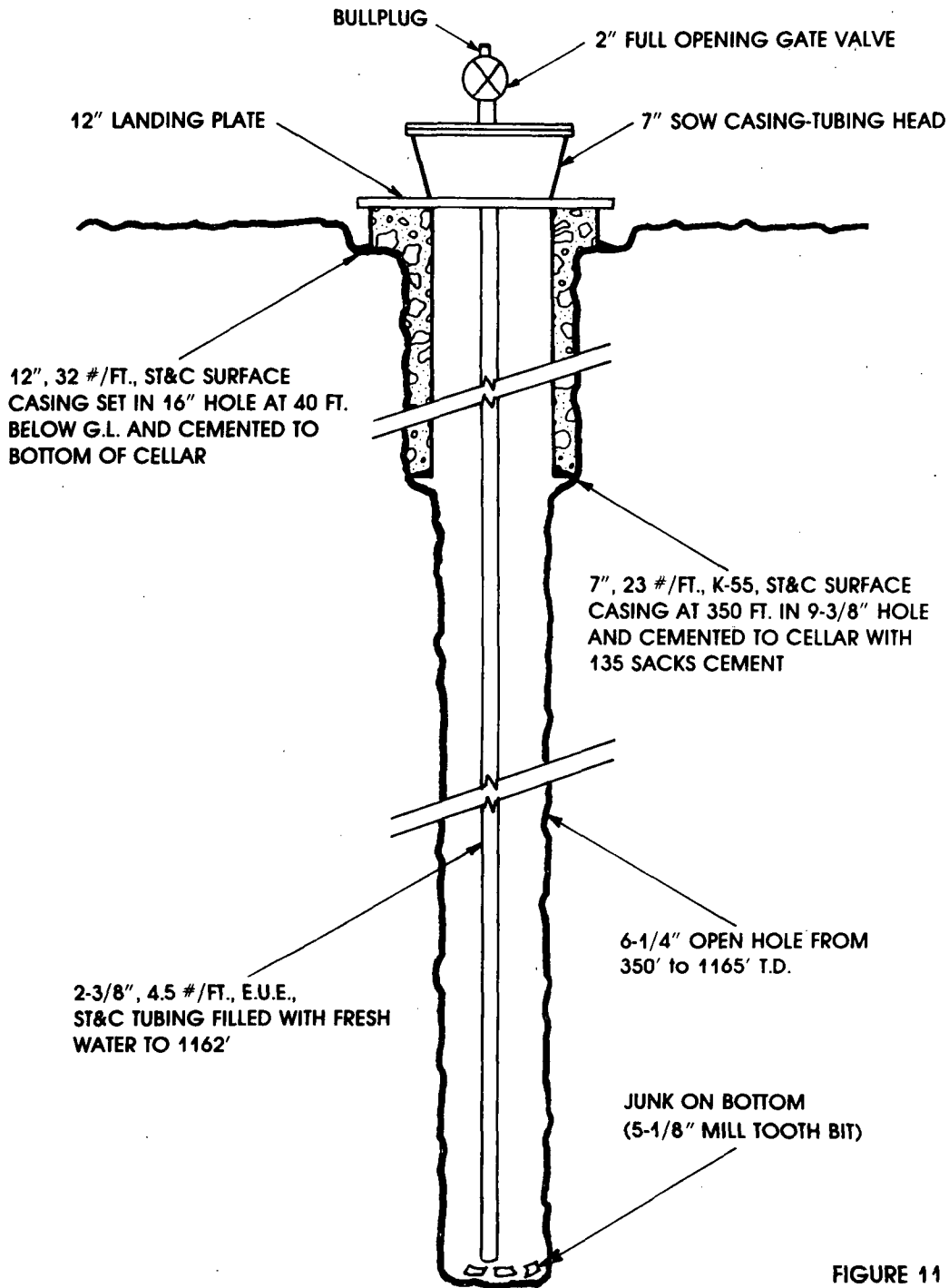

FIGURE 11

# LITHOLOGIC AND TEMPERATURE LOGS FOR IGH-2

T.27N., R.32E., SEC. 10

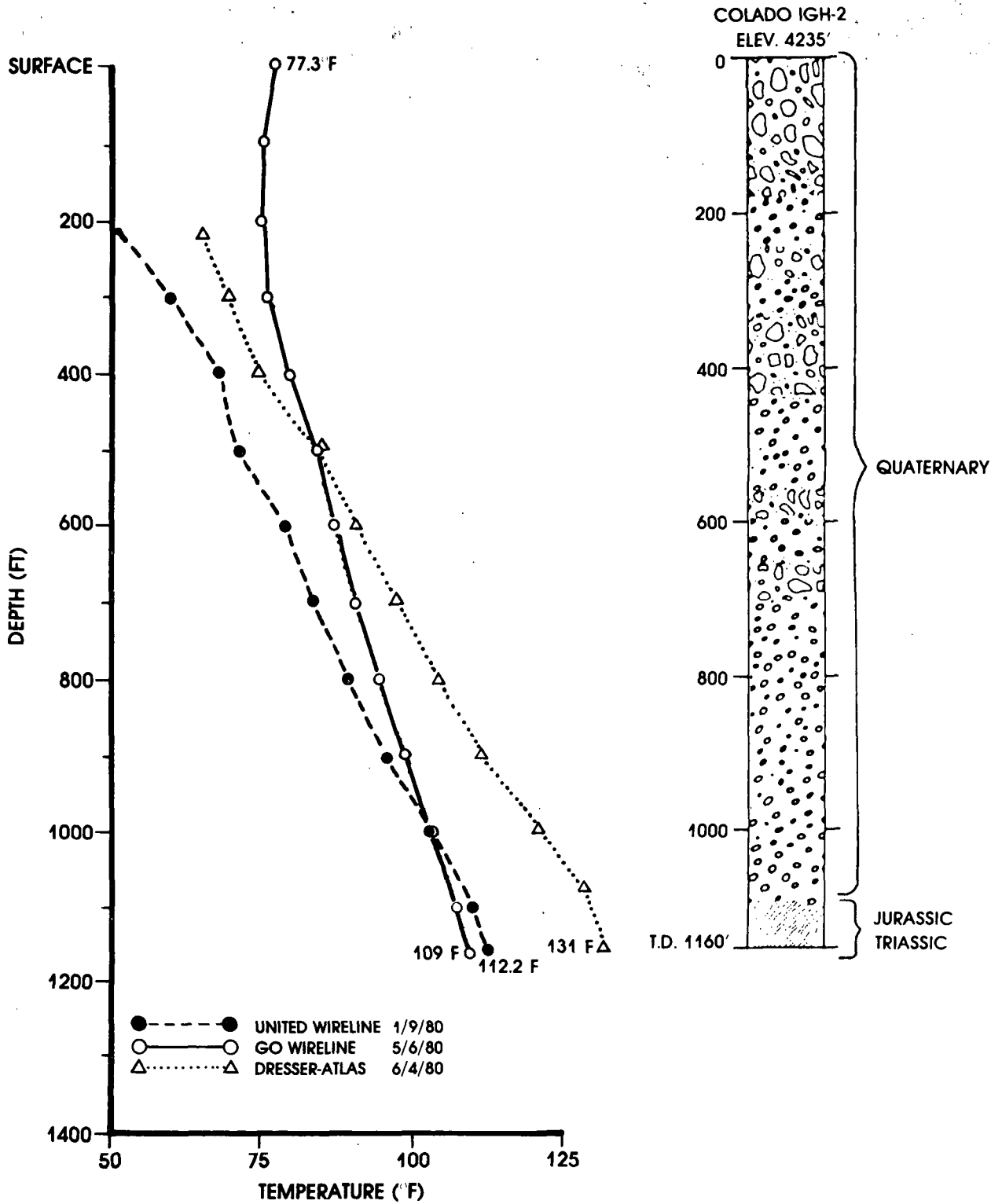

FIGURE 12



# DRILLING PROGRESS CHART USL-44x-10

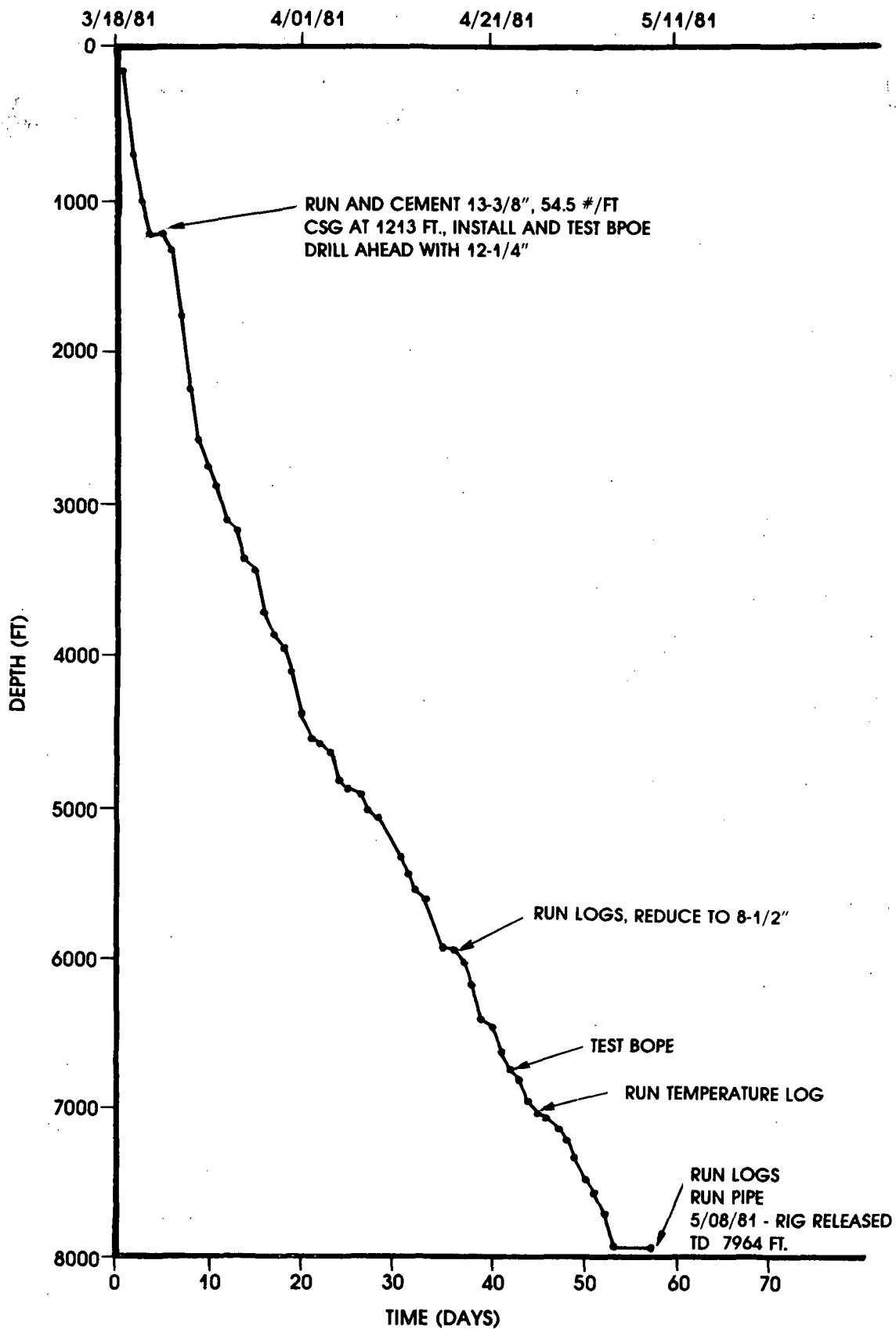

FIGURE 13

# HOLE COMPLETION STATUS FOR USL-44x-10

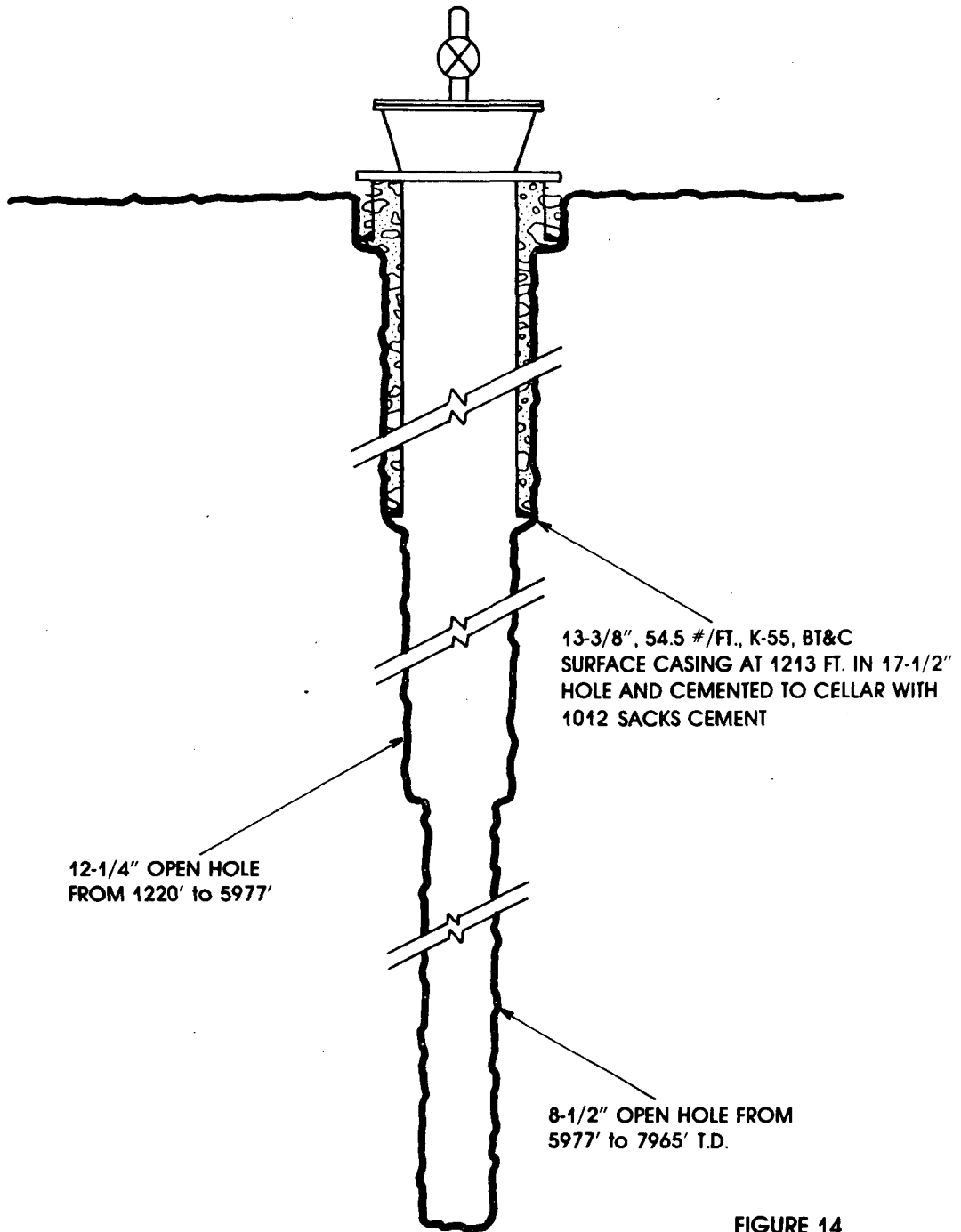

FIGURE 14

Figures 15 and 16 are the results of the down-the-hole deviation surveys. Directional data for the upper 1,200 feet are sparse, but the trend, as shown in Figure 16 is well established. Marked changes in the dip and deflection angles correlate well with changes in rock type (Figure 17). The influence of rock type and inferred rock permeability on temperature can be seen in Figure 18. A listing of all logs run in this hole is given in Appendix C. Reproductions of all borehole logs are available from:

Rocky Mountain Well Log Service

Post Office Box 3150

Denver, CO 80201-3150

Telephone: (303) 740-7100

Approximate total costs for drilling Well 44X-10 are given in Appendix F.

# DEPTH AND DEFLECTION PROFILE, 44x-10

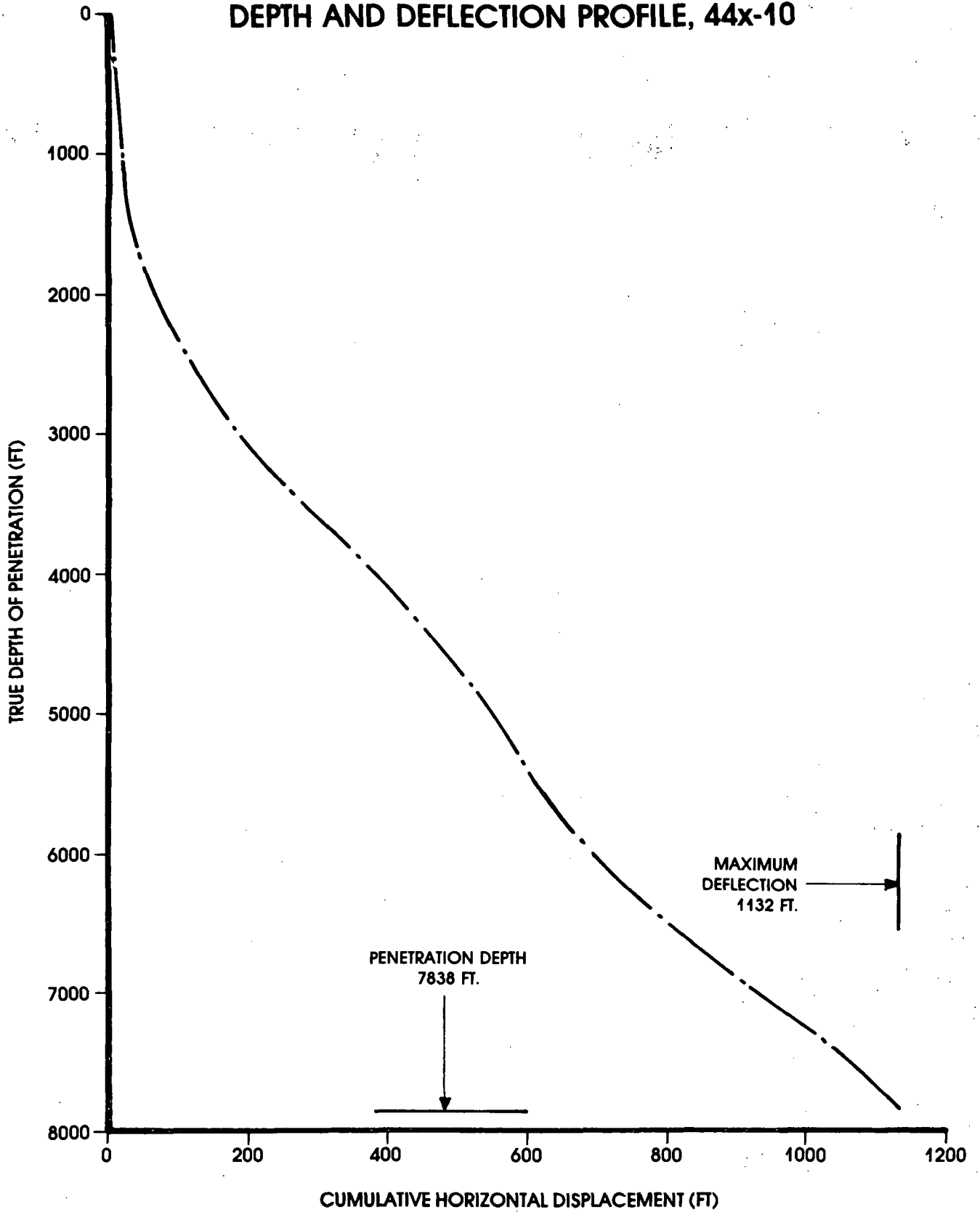

FIGURE 15

# DIRECTIONAL SURVEY, 44x-10

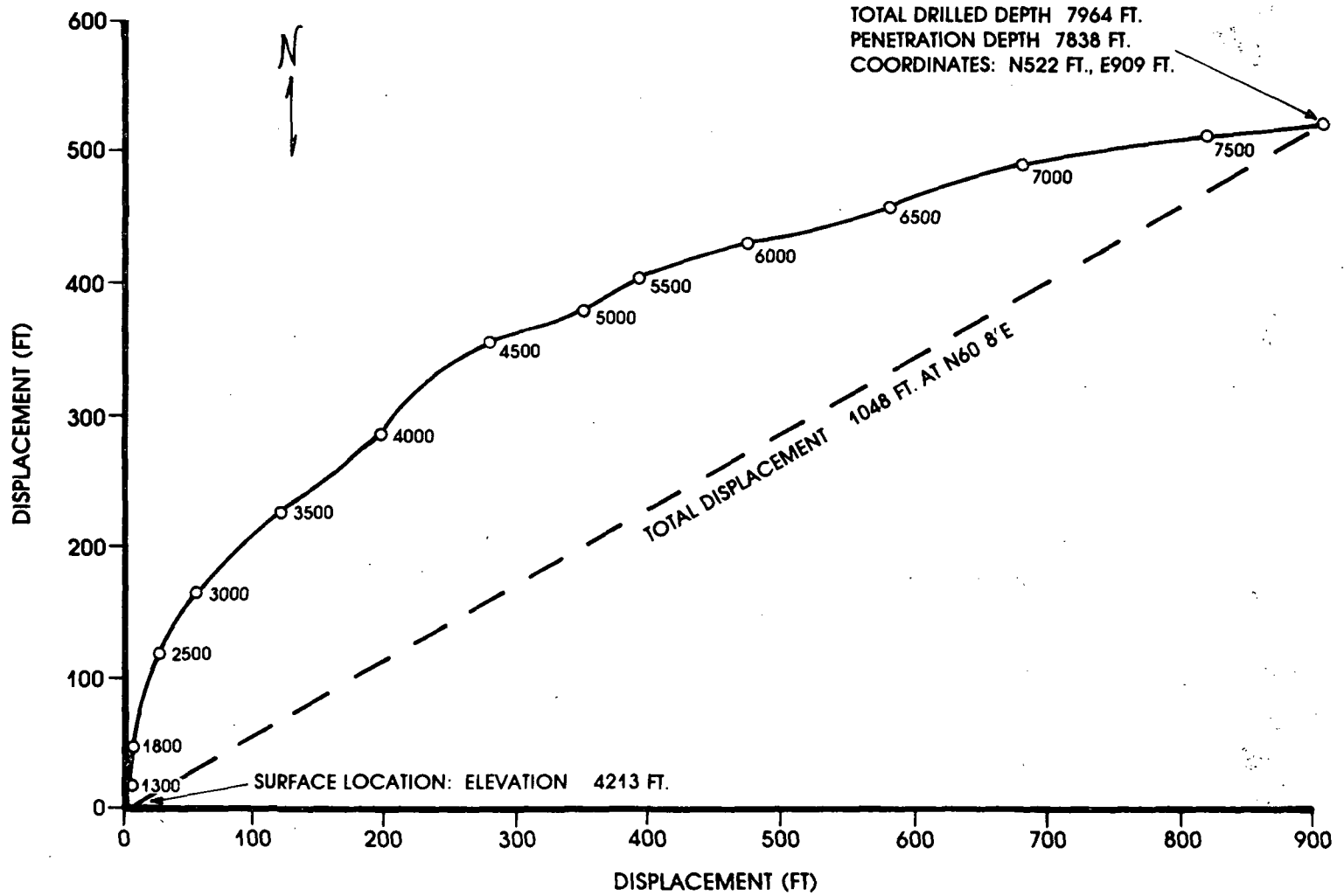

FIGURE 16

picked up single, could not regain circulation after connection. Stuck drill pipe, worked pipe, pumped mud, got loose at 2140 hours. Pulled up, set back six stands, secured location at 2230 hours.

3/15/80. Start at 0715 hours; pulled out of hole to check bit. Mised conditioned mud, added barite; mud weight 9-9.5#. Staged back to bottom, reamed tight spots in the hole. Circulated off bottom, rerigged shaker. Flow line temperature 98-100°F with mud. Heavy mud shut off hot fluid entry into hole. Drilled till 2200 hours, pulled back to 1000 feet, shut down rig at 2230 hours; depth 1313 feet. Formation is hard, dense black phyllitic slate with thin interbeds of fine sand and clay stringers.

3/16/80. Start at 0750 hours; rig, mud hose, pits all partially frozen; overnight temperature 15°F. Thawed out, ran to bottom, drilled ahead till 2145 hours; depth 1501 ±. Pulled up six stands, filled hole with mud, secured rig at 2245 hours. Released strata-Log logging unit.

3/17/80. Start at 0815 hours; ran to bottom, circulated for 20 minutes, hole in excellent shape. Schlumberger on location, pulled out of hole, rigged up Schlumberger, ran in hole with DILL Log at 1105. Logged out, ran in hole with FDC-CNL Sonde and temperature tool on top. Temperature tool ceased to function in open hole. Ran Sonic, N.G., rigged down loggers. Secured location at 1900 hours.

3/18/80. Start at 0700 hours; ran in hole with bit to 1500 feet (total depth), circulated for 15 minutes. Pulled out of hole, layed down drill pipe and collars. Out of hole at 1105 hours. Filled hole with heavy mud, tore out BOPE including pitcher nipple, blowdown and kill lines to casing head. Ran 47 joints including one 10 foot pup of 2 3/8 inch, 417# E.U.H. ST&C tubing and hung at 1482 feet ± from 7 feet combination casing-tubing flange bolted to the casing head. Filled with fresh water and installed 2 inches full gate valve above tubing flange. Well finished 1800 hours; released Contractor.

3/19/80. Clean up location.

# LITHOLOGIC LOG FOR USL - 44x-10

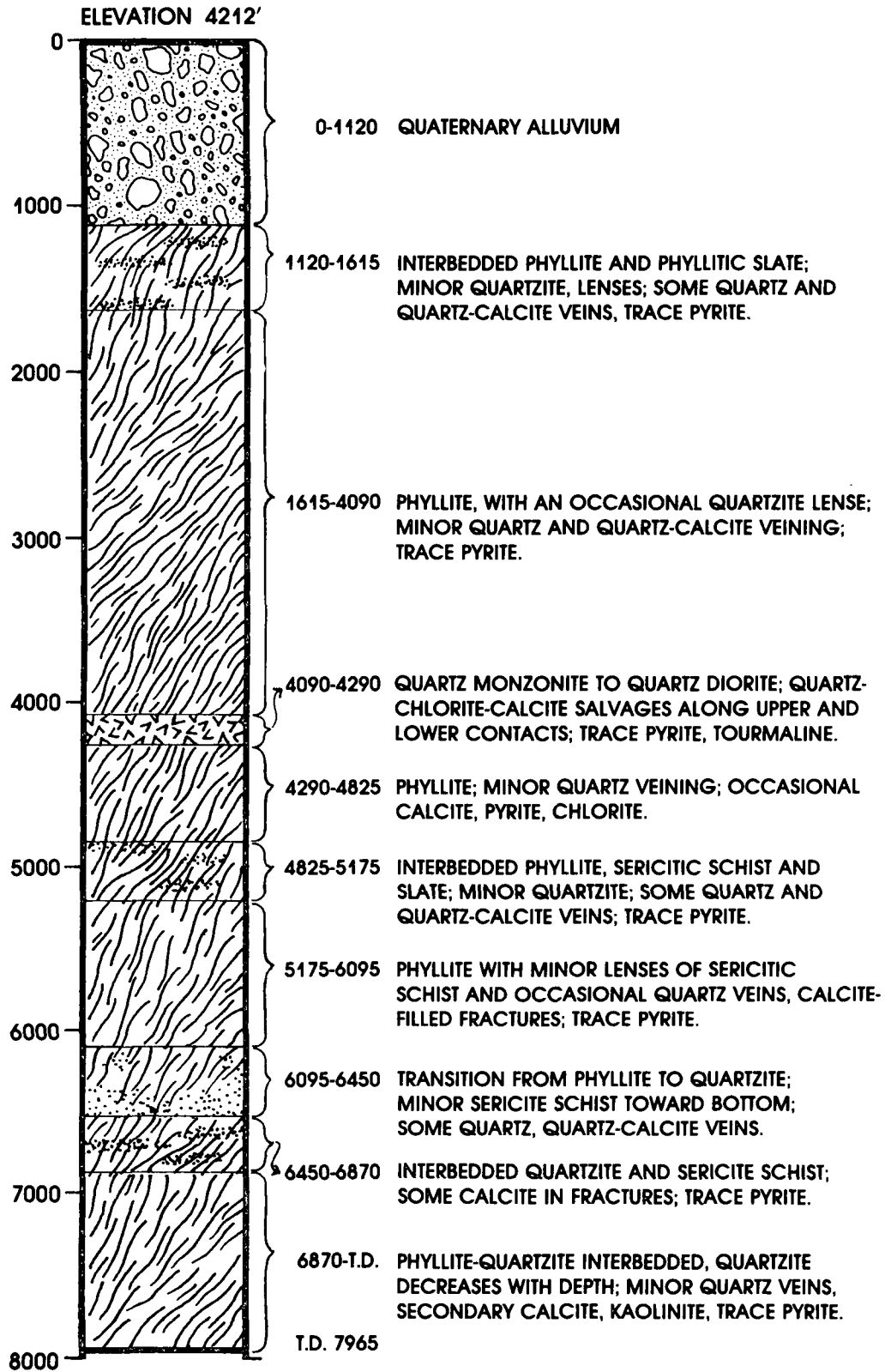

FIGURE 17

# TEMPERATURE PROFILES 44x-10

T.27N., R.32E., SEC. 10

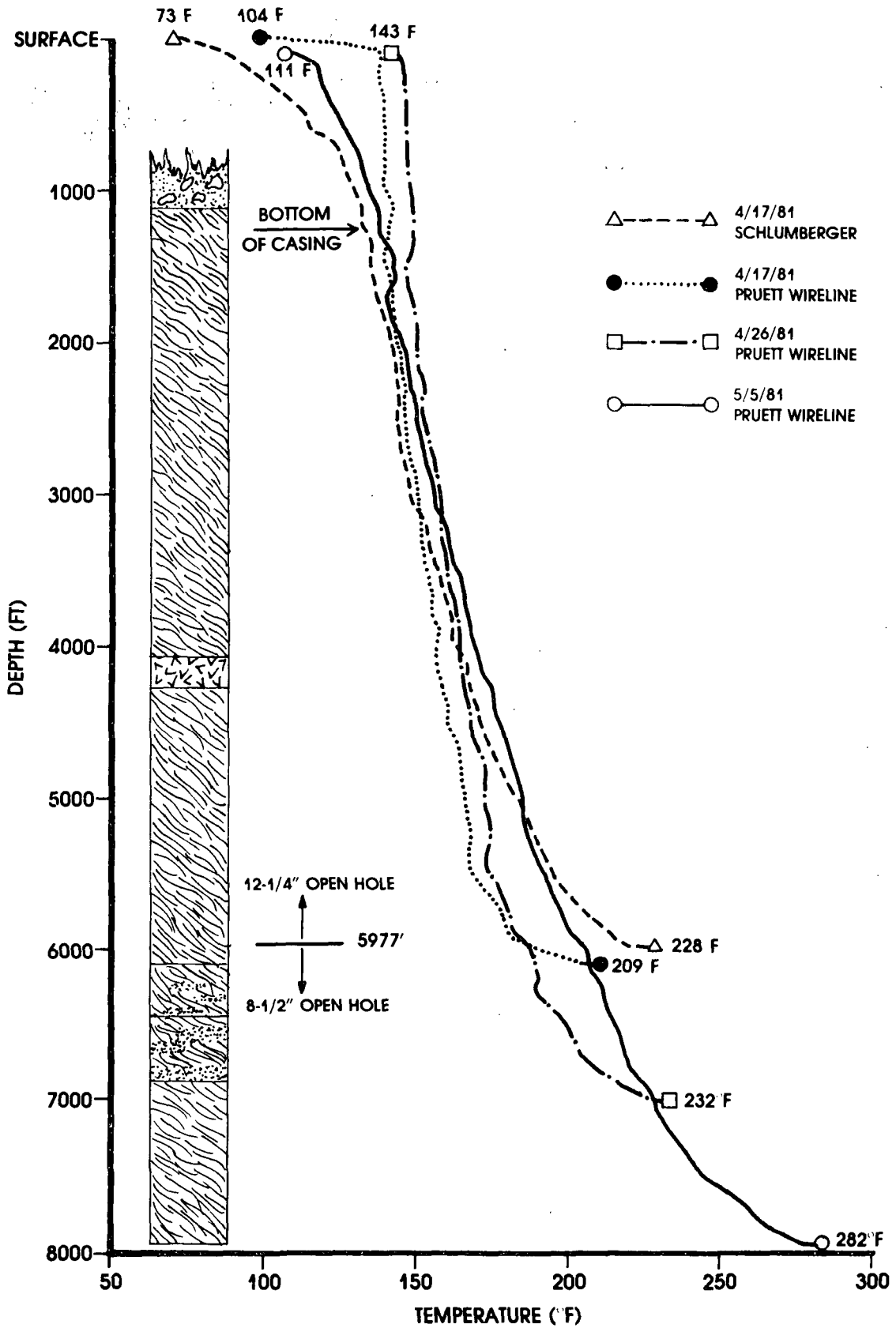

FIGURE 18



APPENDIX A-1

SUMMARY OF DAILY REPORTS

USL-IGH #1

3/4/80. K. O. Bert Drilling Co., Inc.'s rig arrived on location at 1000 hours. Rigged up in preparation to spud. Hauled water, mixed mud, unloaded pipe and other tools. Suction hose to the pump was wrong length, sent Pusher to Reno for new one. One crew went back to Utah for an extra mud pump.

3/5/80. Crew hauled water and refilled pits. Conditioned mud and spudded well at 1700 hours. Drilled one hour with rerun Hughes 9 7/8 inch Tricone Bit. Conditioned mud and circulated hole; repaired rig. Shut down at 2000 hours; will run 12 hour tours only.

3/6/80. Start 0700 hours; depth 66 feet, mud weight 8.9# Gal., Vis. 45-50 sec, Gel-H<sub>2</sub>O system. Ran in hole, drilled ahead, lost circulation at 135 feet, mixed LCM into mud system. Drilled ahead with partial returns, regained whole system 175-180 feet. Bit plugged at 198 feet; pulled out of hole at 1500 hours to clean the bit. Jets and bit sub plugged with rocks. Ran to bottom, drilled ahead to 1900 hours; taking some fluid. Mixed mud and LCM during drilling operations. Pulled off bottom, shut rig down at end of shift; depth 236 feet.

3/7/80. Start 0700 hours; backhoe called to clean out pits; berms raised all around to increase volume and allow cuttings to drop out. Mixed and conditioned mud; on bottom and drilling ahead at 1300 hours. Extra mud pump arrived, now can mix and jet pits while drilling ahead with other pump. Drilled until 1500 hours; pulled out of hole, bit not cutting hard quartzite formation. Lost circulation during drilling. Mixed new mud and LCM, filled hole with mud. Put crew on standby and shut rig down from 1600 to 1900 hours while waiting on new bit. Depth is 269 feet; formation is hard, dense chert.

3/8/80. Start 0700 hours; ran a new Smith 9 7/8-inch journal insert bit into the hole. Drilling ahead by 0850 hours. Mixed and conditioned mud, hole taking fluid, on and off circulation. Mixed mud and LCM all day. Hit hard black phyllitic slate at 345 feet. Made hole down to 351 feet (casing point) at 1645 hours. Pulled off bottom, mixed heavy mud, added LCM and pumped hole slowly, pulled up 100 feet, repeated circulation procedures and pumped hole for 15 minutes. Hole stabilized at this point. Pulled out of hole at 1830 hours, filled hole with mud, secured rig at 1900 hours. Made arrangements for a pump truck and a bulk truck.

3/9/80. Start 0700 hours; ran in hole with bit to turn over mud, tagged bottom, pulled up and circulated for 20 minutes. Hole OK, fluid level in pits held constant. Pulled out of hole. Measured casing; started shoe joint in hole at 1000 hours. Ran 19 joints of K55, 23#, 8Rnd, ST&C to 361 feet. Bottom 10 foot shoe joint equipped with drillable cement guide shoe and insert valve at the top dressed with a centralizer and at each 80 foot thereafter. Tack welded each collar except last three inside conductor pipe. Rigged up B. J. Hughes Cementers at 1330 hours. Loaded H<sub>2</sub>O, dropped ball, pressured up, ruptured insert valve at 200#, mixed cement, sent 30 cu.ft. H<sub>2</sub>O ahead, followed with 135 sacks class "G" cement treated with 3 percent CaCl<sub>2</sub>; pumped down annulus, good returns immediately. Pumped away 15 sacks, voided rest into sump. Rigged down B. J. Hughes at 1650 hours, cleaned out 1 inch pipe, Standing cemented at 1700 hours.

3/10/80. Start 0700 hours; cut off 12 inch conductor one foot below ground level. Cut off 7 inch casing, welded on landing plate and 7 inch SOW Casing Head. Installed a Shaftco Hydraulic Class II 3000# Blow Out Preventer. Cleaned out mud pits with a backhoe, ran flow line to shaker, mixed mud, make up Hughes 6 1/4 inch rerun bit. Ran in hole to 200 feet, closed Pipe Rams, pressured up to 300#, held pressure for 10 minutes, no leaks. Closed flow line valve to mud pump, held pressure at 300# for 15 minutes. Tested OK, bled off pressure, opened rams, ran to bottom, drilled out insert valve, 10 feet cement and guide shoe. Drilled ahead to 368 feet, hole took some fluid. Secured rig at 1845 hours.

3/11/80. Mixed and conditioned mud, added LCM, drilled ahead with partial returns. Bottoms up temperature 114<sup>0</sup>F. Drilled till 0930 hours. Pulled up, dropped Totco. Pulled out of hole to change bits; depth 387 feet. Totco 6<sup>0</sup> with baffle ring turned sideways on top of bit. Ran in hole with Hughes 6 1/4 inch rerun bit. On bottom and drilling ahead at 1120 hours. Drilled to 448 feet in hard, dense, black phyllitic slate with trace of pyrite and quartz. Secured rig at 1900 hours.

3/12/80. Start at 0700 hours; ran bit to bottom, broke off Kelly, dropped Totco. Pulled out of hole with bit, deviation now 5 1/2<sup>0</sup>. Rigged up air hammer and compressor; on bottom with hammer at 0945 hours, blew mud out of hole, drilled ahead at 1100 hours. Shut down, made shield for table, drilled until 1830 hours. Set back two stands, shut down for the night; depth 672 feet. Hit hot water aquifer at 445-450 feet, temperature 140-150<sup>0</sup>F, flow from the hole at 30-50 gpm mixed with foam.

3/13/80. Start at 0730 hours; ran to bottom, drilling ahead at 0755 hours. Pulled out of hole to check hammer; depth 712 feet. Changed to 6 1/8 inch hammer, ran in hole, pressured up, blew fluid out, drilled ahead to 732 feet. Flow line temperatures 150-160<sup>0</sup>F. Pulled out of hole to change to a tricone bit; decision for bit change based on low circulation rate through hammer ports if mud were needed to kill the well. With bit change, reamed down last two singles of 6 1/8 inch hammer hole, drill additional 15 foot before bit is plugged. Pulled out of hole, on bank at 1730 hours. Drill collar sub and bit are full of gravel, cleaned them out, put in check valve and reassembled. Ran in hole and secured location at 1945 hours; depth 747 feet.

3/14/80. Start at 0715 hours; ran to bottom, pressured up air, drilled ahead. Drilling rate 60'/hr, made hole till 1415 hours; depth 1047 feet, circulation temperature 155-158<sup>0</sup>F. After connection, temperature went to 174-178<sup>0</sup>F for 5-10 seconds. Drilled to 1,107 feet. Pulled back to 700 feet to wipe hole. On bottom and drilling at 1720 hours. Lost circulation, pulled up 120 feet, added more soap emulsifier, staged back to bottom, drilled ahead to 1,147 feet,

APPENDIX A-2

SUMMARY OF DAILY REPORTS

USL-IGH #2

10/29/79. Southwest Drilling and Exploration Inc., Rig #7 arrived on location at 0845 hours. Rigged up, mixed mud, picked up drill collars and drill pipe.

10/30/79. Spudded well with a 9 7/8 inch Hughes mill-tooth bit at 0905 hours. Drilled to 280 feet. Pump broke down, repaired, conditioned mud and drilled ahead. Mud weight 68#, viscosity 50 seconds.

10/31/79. Finished drilling hole to 350 feet; putted off bottom, circulated mud in hole and prepared to run 7 inch casing. Pulled up 5 singles (100 feet), but ran into a bridge at 250 feet; good circulation even though the drill pipe was stuck. Worked the pipe, changed over to air, blew up loose rocks and boulders; pipe free, pulled one single (20 foot) and hit new bridge. Worked pipe free; circulating. Hauled diesel fuel.

11/1/79. Hauled water, pulled collars out of hole, checked bit, conditioned mud (weight 68#, viscosity 52), ran in hole to 180 feet; pump down, fixed; conditioning hole, staged down and wiped hole every 100 feet. Circulated while on bottom till 1400 hours. Pulled out of hole, called Case Tong Services for casing tools. Ran in hole at 2000 hours, turned over mud, pulled out of hole and prepared to run casing. Started in hole with 7 inch at 2230 hours. Ran 17.5 joints 23# ST&C K-55 casing. Bottom 10 feet shoe joint centralized at top and each 80 feet thereafter. Casing on bottom at 0315 hours, rigged down casing tools, rigged up J. B. Hughes Cementers. Pumped 10 cu/ft water ahead, pressured up, tried to rupture insert valve; broke off head, reciprocated casing, put back on cement head, repressured, valve ruptured at 200#. Started mixing cement at 0540 hours, finished at 0554. Pulled up, removed slips from spider, started displacing at 0600 hours. Finished displacing with mud, load and bump plug with 700#; casing in place at 0625 hours.

11/2/79. Worked over casing for 6 hours; tore out flowline, cut off conductor and casing, welded on 12 inch landing plate and 7 inch SOW casing-tubing head. Nippled up Shaftco-Class II 3000# Double Gate Blow Out Preventer. Shored up rig, installed flow line to discharge pit and ran in hot with a Hughes 6 1/4 inch mill-tooth bit. Mud weight 68.2#, viscosity 67.

11/3/79. Could not get pitcher nipple to seal, rewelded. Drilled out baffle, cement and cement guide shoe at 348 feet. Drilled ahead until 1150 hours. Clutch out, shutdown, repaired, drilling ahead at 1300 hours; pump went out, down for repairs, welded on slips for connection. At 1532 hours the pulldown chain on the left side broke; Kelly cocked over, difficult to drill ahead; pump barely pumping. At 1700 hours a roller fell out of X-member from derrick. Lowered mast, straightened X-member and put rollers back into vertical tracks; drilling ahead.

11/4/79. Broke pulldown chain on right side, drilled without weight until 0130 hours. Cross-member supporting Kelly broke; drilled until 0405 hours, welded on blocks. Drilled ahead, broke X-member again, pulled up into 7 inch casing with drill pipe and bit, laid down mast. Replaced member and rewelded, came out of hole, changed bits, ran back into hole. Pressure tested BOPE with bit still inside 7 inch casing. Hole depth 640 feet. Closed pipe rams, pressured up to 500#; blew popoff valve. Closed, repressured with 200-500# for one hour; held ok, no leaks. Drilling ahead. Added ICM as hole taking some fluid.

11/5/79. Drilling ahead; added chemical to mud to reduce viscosity and water loss. Pump plugged; cleaned out and drilled ahead. Pulldown chain broke twice, finally repaired at depth of 860 feet. Mud weight 68#, viscosity 55. Pump also down twice during night.

11/6/79. Pulled out of the hole at 920 feet to change bits; left one cone in the hole. Called Midway Fishing Tools for magnet after failure to sidetrack following reaming operation. Brought in backhoe from Lovelock, Nevada, to clean out mud pits; fixed pump.

11/7/79. Made up magnet and junk sub on drill pipe, ran in and out of hole, recovered fish. Made up new bit and ran it into hole. Poor penetration; bit balling up in hard clay. Put on OWG-J medium soft bit, but it soon quit cutting. Circulated, then pulled out of hole at 0105 hours. Ran in hole with 5 3/4 inch drag bit; on bottom at 0430 hours, drilling ahead; mud weight 68, viscosity 58.

11/8/79. Lost circulation, 0805 hours at 1162 feet. Mixed H<sub>2</sub>O, gel, cottonseed pellets, paper ox and other materials, pumped away. Bit plugged, pipe torqued up, so pulled and changed bits and cleaned out float collar valve. Ran in hole with 6 1/4 inch Hughes mill-tooth bit; on bottom and drilling at 2050 hours. Drilled one foot and lost circulation. Tried to drill ahead, bit and drill pipe torqued very badly. Pulled back to 580 feet, shut rig down.

11/9/79. No drilling.

11/10/79. Serviced and started up rig, changed bits, ran in with a short tooth insert bit. Reamed tight hole from 1000 feet to 1040 feet. On bottom, drilled through hard, abrasive, fractured material; circulation problems. Conditioned mud, drilled ahead with partial returns; drill pipe torqued up very badly. Pulled back to 700 feet and shut rig down for the night.

11/11/79. Worked on water truck. Pulled out of hole; had to use torch to heat and break out drill pipe; completed job at 1230 hours. Rig down--waiting on tools.

11/12/79. Waiting on tools.

11/13/79. Welded on rig, tool joints and slips. Picked up reamer and stabilizer. Ran in hole with rerun bit to 910 feet ±; reamed to bottom, tried to drill ahead--torqued up. Pulled out of hole, ran junk basket, no junk.

1/14/79. Ran in hole with a 5 1/8 inch rock bit to drill pilot hole. On bottom, tried to make hole, spun bit off; left it in hole. Pulled out, put on overshot,

ran in hole, fished, could not recover. Pulled out of hole, wait on fishing tools. Ran in hole at 1600 hours to circulate and condition hole preparatory to run Midway Double Grab. Pulled out of hole.

11/15/79. Made up Midway Tools; ran in hole, fished, did not recover fish. Pulled out of hole.

11/16/79. Ran fishing tools, could not recover fish, put drill crew on standby, called Schlumberger. Released Smith Logging Unit. Will run logs and complete at 1165 feet, which is the present total depth.

11/17/79. Ran in hole with bit, circulated and conditioned hole, came out of hole. Rigged up Schlumberger, ran logs and temperature tool. Logging completed. Rigged down Schlumberger and made bit run to bottom. Came out of hole. Laid down drill pipe and collars, tore out blow out preventor, drilling spool and kill lines.

11/18/79. Made up tools and ran 37 joints and one 10 foot pup of 2 3/8 inch, 4.5# E.U.E., tubing to 1162 feet  $\pm$ . Hung tubing from tubing head and made up 2 inch full opening gate valve on top. Filled tubing with water. Hole finished at 1015 hours. Rigged down, well completed and Contractor released at 1200 hours.

APPENDIX A-3

SUMMARY OF DAILY REPORTS

COLADO 44X-10 (6:00 AM REPORT)

3/14/81. Spud at 1130 hours, 3/13/81. Drill 17 1/2 inch hole from 165 feet to 702 feet (537 feet in 18 1/2 hours-29 ft/hr). Mud weight 67 pcf, viscosity 39.

3/15/81. Drill 17 1/2 inch hole from 702 feet to 1006 feet (304 feet in 24 hours-15 ft/hr). Mud weight 66 pcf, viscosity 40.

3/16/81. Drill 17 1/2 inch hole from 1006 feet to 1215 feet (209 feet in 11 hours-19 ft/hr). Run 31 joints of 13 3/8 inch-54.5# K-55 BT&C casing to 1213 feet. Cement with 640 sacks "G" 1:1 perlite, 40 percent silica flour followed by 200 sacks of Class "G" with 40 percent silica flour. No cement returns. C.I.P. 3:00 AM.

3/17/81. Tag top of cement at 186 feet with 1 inch pipe. Cement with 172 sacks of Class "A" cement. Good returns. Install 13 3/8 inch well head. Test welds to 2500 psi.

3/18/81. Install and test BOPE to 1000 psi. Test witnessed and approved by USGS. Drill 12 1/4 inch hole to 1320 feet (105 feet in 6 hours-18 ft/hr). Mud weight 64 pcf, viscosity 30, temperature in, 74<sup>0</sup>F; temperature out, 82<sup>0</sup>F. Survey-2<sup>0</sup> at 1320 feet.

3/19/81. Run in hole with new bit. Drill 12 1/4 inch hole 1320 feet to 1769 feet (449 feet in 16 hours-27 ft/hr). Mud weight 65 pcf, viscosity 35, temperature in, 90<sup>0</sup>F; temperature out, 97<sup>0</sup>F. Survey-2<sup>0</sup> 15' at 1472 feet.



3/20/81. Drill 12 1/4 inch hole from 1769 feet to 2239 feet (407 feet in 19 hours-25 ft/hr). Mud weight 65 pcf, viscosity 30, temperature in, 85°F; temperature out, 104°F. Survey-4° 30' at 1824 feet, 6° at 2044 feet, 6° at 2139 feet, 6° at 2261 feet.

3/21/81. Drill 12 1/4 inch hole from 2239 feet to 2586 feet (347 feet in 21 hours-17 ft/hr). Put out of hole for bit. Mud weight 67 pcf, viscosity 35, temperature in, 107°F; temperature out, 112°F. Survey-6° 15' at 2356 feet, 6° at 2480 feet, 6° at 2542 feet.

3/22/81. Drill 12 1/4 inch hole from 2586 feet to 2732 feet (146 feet in 16 hours-9 ft/hr). Mud weight 66 pcf, viscosity 37, temperature in, 108°F; temperature out, 115°F. Survey-6° 15' at 2636 feet.

3/23/81. Drill 12 1/4 inch hole from 2732 feet to 2879 feet. Pull out of hole for bit change. Run new bit. Drill 12 1/4 inch hole from 2879 feet to 2885 feet (53 feet in 16 hours-3 ft/hr). Mud weight 66 pcf, viscosity 35, temperature in, 108°F; temperature out, 110°F. Survey-7° 30' at 2827 feet, 7° 15' at 2879 feet.

3/24/81. Drill 12 1/4 inch hole from 2885 feet to 3110 feet (225 feet in 21 hours-11 ft/hr). Mud weight 66 pcf, viscosity 35, temperature in, 109°F; temperature out, 117°F. Survey-9° 30' at 2907 feet, 9° at 2941 feet, 10° at 2972 feet, 10° at 3004 feet, 10° at 3036 feet, 10° at 3069 feet.

3/25/81. Drill 12 1/4 inch hole from 3110 feet to 3170 feet. Pull out of hole to install monel and new bit. Run in and drill 12 1/4 inch hole from 3170 feet to 3197 feet (87 feet in 7 1/2 hours-12 ft/hr). Mud weight 65 pcf, viscosity 35, temperature in, 109°F; temperature out, 116°F. Survey-10° at 3170 feet.

3/26/81. Drill 12 1/4 inch hole from 3197 feet to 3386 feet (189 feet in 16 hours-12 ft/hr). Twist off monel. Run overshot. Pull out of hole with fish. Mud weight 65 pcf, viscosity 34, temperature in, 109°F; temperature out, 115°F. Survey-10° 45' at 3170 feet.

3/27/81. Run in hole with new bottom hole assembly. Drill 12 1/4 inch hole from 3386 feet to 3438 feet (52 feet in 5 1/2 hours-10 ft/hr). Mud weight 65 pcf, viscosity 35, temperature in, 101°F; temperature out, 109°F. Survey-10° 45' at 3389 feet.

3/28/81. Drill 12 1/4 inch hole from 3438 feet to 3721 feet (283 feet in 23 hours-12 ft/hr). Mud weight 65 pcf, viscosity 34, temperature in, 113°F temperature out, 119°F. Survey-11° 30' at 3502 feet, 11° 30' at 3721 feet.

3/29/81. Drill 12 1/4 inch hole from 3721 feet to 3863 feet (142 feet in 13 hours-11 ft/hr. Change bits. Mud weight 65 pcf, viscosity 34, temperature in, 114°F; temperature out, 120°F. Survey-12° at 3863 feet.

3/30/81. Drill 12 1/4 inch hole from 3863 feet to 3963 feet (100 feet in 13 1/2 hours-7 ft/hr). Change bits. Mud weight 65 pcf, viscosity 35, temperature in, 102°F; temperature out, 119°F. Survey-11° at 3922 feet, 10° 30' at 3954 feet.

3/31/81. Drill 12 1/4 inch hole from 3963 feet to 4104 feet (141 feet in 11 hours-12 ft/hr). Mud weight 65, viscosity 34, temperature in, 112°F; temperature out, 121°F. Survey-9° 45' N71°E at 3996 feet, 10° 15' at 4091 feet.

4/01/81. Drill 12 1/4 inch hole from 4104 feet to 4384 feet (280 feet in 22 hours-13 ft/hr). Mud weight 66 pcf, viscosity 35, temperature in, 116°F; temperature out, 125°F. Survey-10° 45' N24°E at 4249 feet; 12° N56°E at 4379 feet.

4/02/81. Drill 12 1/4 inch hole from 4384 feet to 4546 feet (162 feet in 22 hours-8 ft/hr). Pulling for bit change. Mud weight 66 pcf, viscosity 35, temperature in, 123°F; temperature out, 128°F. Survey-10° 15' at 4439 feet, 11° 45' at 4535 feet.

4/03/81. Run in with new bit. Drill 12 1/4 inch hole from 4546 feet to 4594 feet (48 feet in 15 hours-3 ft/hr). Mud weight 65 pcf, viscosity 34, temperature in, 120°F; temperature out, 130°F. Survey-11° 45' at 4546 feet, 11° 30' at 4592 feet.

4/04/81. Drill 12 1/4 inch hole from 4594 feet to 4655 feet. Change bits. Drill 12 1/4 inch hole from 4655 feet to 4684 feet (78 feet in 11 hours-7 ft/hr). Mud weight 65 pcf, viscosity 33, temperature in, 114°F; temperature out, 125°F. Survey-11°, N80°E at 4655 feet.

4/05/81. Drill 12 1/4 inch hole from 4684 feet to 4818 feet (134 feet in 21 hours-6 ft/hr). Mud weight 65 pcf, viscosity 32, temperature in, 121°F; temperature out, 132°F. Survey-10° 30' N83E at 4750 feet; 9° 45', N71E at 4813 feet.

4/06/81. Drill 12 1/4 inch hole from 4818 feet to 4830 feet. Change bits. Drill 12 1/4 inch hole from 4830 feet to 4886 feet (68 feet in 18 hours-4 ft/hr). Mud weight 65 pcf, viscosity 32, temperature in, 119°F; temperature out, 125°F. Survey-9° 30' at 4830 feet, 7° 45' at 4875 feet.

4/07/81. Drill 12 1/4 inch hole from 4886 feet to 4914 feet. Change bits. Drill 12 1/4 inch hole from 4914 feet to 4925 feet (39 feet in 9 hours-4 ft/hr). Mud weight 65 pcf, viscosity 31, temperature in, 116°F; temperature out, 121°F. Survey-7° 30' at 4925 feet.

4/08/81. Drill 12 1/4 inch hole from 4925 feet to 5018 feet (93 feet in 21 hours-4 ft/hr). Mud weight 65 pcf, viscosity 32, temperature in, 123°F; temperature out, 128°F. Survey-7° 15' at 4964 feet.

4/09/81. Drill 12 1/4 inch hole from 5018 feet to 5023 feet. Change bits. Drill 12 1/4 inch hole from 5023 feet to 5079 feet (61 feet in 14 hours-4 ft/hr). Mud weight 64 pcf, viscosity 33, temperature in, 124°F; temperature out, 126°F. Survey-6° 45' at 5027 feet.

4/10/81. Drill 12 1/4 inch hole from 5079 feet to 5239 feet (160 feet in 21 hours-8 ft/hr). Mud weight 64 pcf, viscosity 33, temperature in, 122°F; temperature out, 127°F. Survey-6° 45' N54°E at 5089 feet; 6° 45' N54°E at 5152 feet.

4/11/81. Drill 12 1/4 inch hole from 5239 feet to 5334 feet (95 feet in 12 hours-8 ft/hr). Change bits. Mud weight 69 pcf, viscosity 34, temperature in, 118°F; temperature out, 124°F. Survey-6° 15' N53°E at 5277 feet.

4/12/81. Drill 12 1/4 inch hole from 5334 inch to 5468 feet (134 feet in 23-hours-6 ft/hr). Mud weight 64 pcf, viscosity 35, temperature in, 120°F; temperature out, 129°F. Survey-7° 45' at 5465 feet.

4/13/81. Drill 12 1/4 inch hole from 5468 feet to 5570 feet (102 feet in 18 hours-6 ft/hr). Mud weight 64 pcf, viscosity 35, temperature in, 120°F; temperature out, 129°F. Survey-7° 45' at 5560 feet.

4/14/81. Drill 12 1/4 inch hole from 5570 feet to 5608 feet. Change bits. Drill 12 1/4 inch hole from 5608 feet to 5663 feet (93 feet in 15 hours-6 ft/hr). Mud weight 66 pcf, viscosity 36, temperature in, 124°F; temperature out, 133°F. **(NO SURVEY GIVEN).**

4/15/81. Drill 12 1/4 inch hole from 5663 feet to 5839 feet (175 feet in 23 hours-8 ft/hr). Mud weight 66 pcf, viscosity 35, temperature in, 129°F; temperature out, 135°F. Survey-7° 45' at 5718 feet.

4/16/81. Drill 12 1/4 inch hole from 5839 feet to 5977 feet (139 feet in 16 hours-9 ft/hr). Pull out of hole for logs. Logging. Mud weight 67 pcf, viscosity 35, temperature in, 129°F; temperature out, 138°F.

4/17/81. Run logs (temperature, DIL, FDC-CNL, sonic and caliper).

4/18/81. Run second temperature log. Run in hole with 8 1/2 inch bit and drill from 5977 feet to 6068 feet (91 feet in 9 hours-10 ft/hr). Mud weight 66 pcf, viscosity 37, temperature in, 131°F; temperature out, 139°F.

4/19/81. Drill 8 1/2 inch hole from 6068 feet to 6163 feet. Run temperature survey through drill pipe. Drill 8 1/2 inch hole from 6163 feet to 6202 feet (134 feet in 11 hours-11 ft/hr). Mud weight 67 pcf, viscosity 36, temperature in, 131°F; temperature out, 139°F.

4/20/81. Drill 8 1/2 inch hole from 6202 feet to 6423 feet (221 feet in 21 hours-11 ft/hr). Mud weight 67 pcf, viscosity 37, temperature in, 132°F; temperature out, 140°F. Survey-7° 45' at 6256 feet; 7° 45' at 6320 feet.

4/21/81. Drill 8 1/2 inch hole from 6423 feet to 6490 feet (67 feet in 8 hours-8 ft/hr). Change bits. Mud weight 67 pcf, viscosity 36, temperature in, 131°F; temperature out, 141°F. Survey-12° at 6415 feet; 12° 15' at 6445 feet.

4/22/81. Drill 8 1/2 inch hole from 6490 feet to 6660 feet (170 feet in 22 hours-8 ft/hr). Mud weight 67 pcf, viscosity 35, temperature in, 138°F; temperature out, 145°F. Survey-12° 15' at 6512 feet; 12° 15' at 6573 feet.

4/23/81. Drill 8 1/2 inch hole from 6660 feet to 6768 feet (108 feet in 18 hours-6 ft/hr). Change bits. Mud weight 67 pcf, viscosity 35, temperature in, 138°F; temperature out, 146°F. Survey-12° 15' at 6668 feet, 13° 15' at 6731 feet.

4/24/81. Test BOPE. Drill 8 1/2 inch hole from 6768 feet to 6834 feet (66 feet in 12 hours-5 ft/hr). Mud weight 67 pcf, viscosity 35, temperature in, 141°F; temperature out, 148°F. Survey-13° 15' at 6824 feet.

4/25/81. Drill 8 1/2 inch hole from 6834 feet to 6988 feet (154 feet in 23 hours-7 ft/hr). Mud weight 67 pcf, viscosity 34, temperature in, 142°F; temperature out, 152°F. Survey-13° 45' at 6918 feet.

4/26/81. Drill 8 1/2 inch hole from 6988 feet to 7056 feet (68 feet in 10 hours-7 ft/hr). Run temperature log. Mud weight 67 pcf, viscosity 35, temperature in, 143°F; temperature out, 152°F. Survey-14° at 7013 feet.

4/27/81. Change bits. Drill 8 1/2 inch hole from 7056 feet to 7085 feet (29 feet in 4 hours-7 ft/hr). Mud weight 67 pcf, viscosity 35, temperature in, 138°F; temperature out, 151°F. Survey-15° 45' N5°E at 7084 feet.

4/28/81. Drill 8 1/2 inch hole from 7085 feet to 7196 feet (111 feet in 19 hours-6 ft/hr). Change bits. Mud weight 67 pcf, viscosity 36, temperature in, 142°F; temperature out, 153°F. Survey-16° at 7147 feet.

4/29/81. Drill 8 1/2 inch hole from 7196 feet to 7236 feet (40 feet in 10 hours-4 ft/hr). Mud weight 67 pcf, viscosity 36, temperature in, 142°F; temperature out, 154°F. Survey-16° at 7240 feet.

4/30/81. Drill 8 1/2 inch hole from 7236 feet to 7364 feet (128 feet in 23 hours-6 ft/hr). Mud weight 67 pcf, viscosity 34, temperature in, 141°F; temperature out, 151°F. Survey-15° at 7360 feet.

5/01/81. Drill 8 1/2 inch hole from 7364 feet to 7510 feet (146 feet in 17 hours-8 ft/hr). Change bits. Mud weight 67 pcf, viscosity 34, temperature in, 142°F; temperature out, 156°F. Survey-15° 30' at 7365 feet; 14° 30' at 7492 feet.

5/02/81. Drill 8 1/2 inch hole from 7510 feet to 7585 feet (75 feet in 12 hours-6 ft/hr). Mud weight 67 pcf, viscosity 35, temperature in, 139°F; temperature out, 156°F. **(NO SURVEY GIVEN)**

5/03/81. Drill 8 1/2 inch hole from 7585 feet to 7709 feet (124 feet in 14 hours-9 ft/hr). Mud weight 65 pcf, viscosity 35, temperature in, 139°F; temperature out, 158°F. Survey-13° 15' at 7651 feet.

5/04/81. Drill 8 1/2 inch hole from 7709 feet to 7964 feet (255 feet in 22 hours-11 ft/hr). Pull out of hole for logs. Mud weight 66 pcf, viscosity 34, temperature in, 140°F; temperature out, 161°F.

5/05/81. Run logs (DIL, dipmeter, sonic, FDC-CNL, temperature).

5/06/81. Run in hole with drill pipe. Fill hole with water. Lay down drill pipe.

5/07/81. Nipple up wellhead. Secure well.

5/08/81. Release drilling rig 1200 hours, 5/8/81.

APPENDIX B-1

ROTARY BIT RECORD-IGH #1

Unknown at time of publication.



APPENDIX B-2  
ROTARY BIT RECORD-IGH #2

---

Run No.	Size	Make	Type	Depth Out	Feet Drilled	Hours On Bit
1	9 7/8"	Hughes	OSC 1J6	350	310	24
2	6 1/4"	Hughes	OSC 16	646	296	7 3/4
3	6 1/4"	Hughes	OSC 3J	940	294	15 1/2
4	6 1/4"	Hughes	OSC 16J	1020	80	5 1/2
5	6 1/4"	Hughes	OWVJ	1055	35	3 1/2
6	5 5/8"	Walker	Drag Bit	1164	109	3 1/2
7	6 1/4"	Hughes	OWVJ	1166	2	2 1/2
8	5 1/8"	Walker	Mac W3	1165	-1	1

---

All bits used were mill tooth. The Walker Mac W3 bit was left in the hole.

## APPENDIX B-3

## ROTARY BIT RECORD-COLADO 44X-10

Run No.	Size	Make	Type	Depth Out	Feet Drilled	Hours On Bit
1	-	-	-	-	---	--
2	-	-	-	1213	---	--
3	12 1/4"	Smith	DGJ	1318	105	6
4	12 1/4"	Smith	F2*	2584	1266	55 1/2
5	12 1/4"	Smith	F3*	2877	293	32 1/2
6	12 1/4"	Smith	F3	3168	291	28 1/2
6 Rerun	12 1/4"	Smith	F3	3384	216	20
7	12 1/4"	Hughes	J33*	3861	477	41 1/2
8	12 1/4"	Smith	L4HJ	3961	100	12 1/2
9	12 1/4"	Smith	F3	4544	583	55
10	12 1/4"	Smith	L4HJ	4653	109	22
11	12 1/4"	Security	M44N	4828	175	27
12	12 1/4"	Hughes	XDV	4914	86	25
13	12 1/4"	Hughes	XWR	5027	113	24 1/2
14	12 1/4"	Hughes	J33	5329	302	43
15	12 1/4"	Smith	F3	5608	279	47 1/2
16	12 1/4"	Hughes	J33	5977	369	49
17	8 1/2"	Hughes	J33	6488	511	48 1/2
18	8 1/2"	Smith	F3	6768	280	41 1/2
19	8 1/2"	Smith	F3	7056	288	45 1/2
20	8 1/2"	Security	S86F*	7196	140	22
21	8 1/2"	Hughes	J44*	7510	314	51
22	8 1/2"	Hughes	J44	7965	455	--

\*Indicates tungsten carbide insert bit; all others are mill tooth bits.

APPENDIX C  
CASING AND TUBULARS

Hole	Hole Diameter	Casing Diameter	Joints	Depth (ft)	Type	Weight #/ft.
IGH #1	9 7/8"	7"	19	361	K55 ST&C	23
	6 1/4"	2 3/8"	47	1482	----	----
IGH #2	16"	12"	2	40	----	32
	9 7/8"	7"	17 1/2	348	K55 ST&C	23
	5 3/4"	2 3/8"	37	1162	EUE	4.5
44X-10	24"	20"	4?	140	----	94
	17 1/2"	13 3/8"	31	1213	K55 BT&C	54.5
	12 1/2"	Open hole		5977		
	8 1/2"	Open hole		7964		

APPENDIX D-1

LOG LISTINGS

IGH-1

3/17/80	Schlumberger Dual Induction Laterolog	Scales: 2" & 5" =100'
3/17/80	Schlumberger Formation Density-Neutron Log	Scale: 5" = 100'
3/17/80	Schlumberger Sonic-Gamma Ray-Caliper Log	Scales: 2" & 5" = 100'
5/6/80	Gearhart-Owen Temperature Log	Scale: 2" = 100'

APPENDIX D-2

LOG LISTING

IGH-2

11/17/79	Schlumberger Dual Induction Laterolog	Scale: 2"	= 100'
11/17/79	Schlumberger Dual Induction Laterolog	Scale: 5"	= 100'
11/17/79	Schlumberger Formation Density-Neutron Log	Scales: 2" & 5"	= 100'
11/17/79	Schlumberger Neutron-Gamma Ray-Caliper Log	Scales: 2" & 5"	= 100'
11/17/79	Schlumberger Borehole Compensated Sonic Log	Scales: 2" & 5"	= 100'
11/16/79	R. F. Smith Lithologic Log	Scale: 2"	= 100'
1/9/80	United Wireline Differential Temperature Log	Scale: 2"	= 100'
5/6/80	Gearheart-Owen Temperature Log	Scale: 2"	= 100'
6/4/80	Dresser Atlas Differential Temperature Log	Scale: 5"	= 100'

APPENDIX D-3

LOG LISTINGS

44X-10

4/16/81	Schlumberger Dual Induction Laterolog	Scales: 2" & 5" = 100'
5/4/81	Schlumberger Sonic, FDC-CNL, Gr.	Scales: 2" & 5" = 100'
4/16/81	Schlumberger High Resolution Dipmeter	Scale: 5" = 100'
5/4/81	Schlumberger High Resolution Dipmeter	Scale: 5" = 100'
4/16/81	Schlumberger Compensated Neutron-Formation Density	Scales: 2" & 5" = 100'
5/4/81	Schlumberger Compensated Neutron-Formation Density	Scales: 2" & 5" = 100'
4/16/81	Schlumberger Sonic, FDC-CNL-Gr	Scales: 2" & 5" = 100'
5/4/81	Schlumberger Dual Induction Laterolog	Scales: 2" & 5" = 100'
4/17/81	Schlumberger Temperature	Scale: 5" = 100'
4/17/81	Pruett Wireline Subsurface Temperature	Scale: 1" = 200'
4/26/81	Pruett Wireline Subsurface Temperature	Scale: 1" = 200'
5/5/81	Pruett Wireline Subsurface Temperature	Scale: 1" = 200'
	Schlumberger Lith-Log Abstract	Scale: 2" = 1000'

APPENDIX E  
WELL COMPLETION NOTICES

E-1-2	USL-IGH #1	COMPLETION REPORT
E-1-3	USL-IGH #2	COMPLETION REPORT
E-1-4	USL-44X-10	COMPLETION REPORT

UNITED STATES  
DEPARTMENT OF THE INTERIOR  
GEOLOGICAL SURVEY

SUBMIT IN DUPLICATE\*

(See other In-  
structions on  
reverse side)

Form approved.  
Budget Bureau No. 42-R355.5.

5. LEASE DESIGNATION AND SERIAL NO.  
USL-N 13320

6. IF INDIAN, ALLOTTEE OR TRIBE NAME

7. UNIT AGREEMENT NAME  
USL

8. FARM OR LEASE NAME  
Colado Area

9. WELL NO.  
1GH#1

10. FIELD AND POOL, OR WILDCAT  
Wildcat

11. SEC., T. R., M., OR BLOCK AND SURVEY  
OR AREA  
Sec. 26, T28N, R32E  
M.D.B. & M.

12. COUNTY OR  
PARISH  
Pershing

13. STATE  
Nevada

WELL COMPLETION OR RECOMPLETION REPORT AND LOG \*

1a. TYPE OF WELL: OIL WELL  GAS WELL  DRY  Other Geothermal

b. TYPE OF COMPLETION: NEW WELL  WORK OVER  DEEP-EN  PLUG BACK  DIFF. RESVR.  Other Temp. Observ

2. NAME OF OPERATOR  
Getty Oil Company

3. ADDRESS OF OPERATOR  
P. O. Box 5237 Bakersfield, California 93388

4. LOCATION OF WELL (Report location clearly and in accordance with any State requirements)\*

At surface 1150' South, 1550' East of NW/Cor

At top prod. interval reported below

At total depth

14. PERMIT NO. DATE ISSUED  
AGS 133-N13320 Aug 6, 1979

15. DATE SPUDDED 3-5-80 16. DATE T.D. REACHED 3-18-80 17. DATE COMPL. (Ready to prod.) 18. ELEVATIONS (DF, RKB, RT, GR, ETC.)\* 4325 ± 19. ELEV. CASINGHEAD

20. TOTAL DEPTH, MD & TVD 1500' 21. PLUG. BACK T.D., MD & TVD 22. IF MULTIPLE COMPL., HOW MANY\* 23. INTERVALS DRILLED BY 1500' ROTARY TOOLS CABLE TOOLS

24. PRODUCING INTERVAL(S), OF THIS COMPLETION—TOP, BOTTOM, NAME (MD AND TVD)\* 25. WAS DIRECTIONAL SURVEY MADE No

26. TYPE ELECTRIC AND OTHER LOGS RUN DILL, FDC-CNL WITH GAMMA-CALIPER, SONIC (NG) TEMP (NG) 27. WAS WELL CORED No

28. CASING RECORD (Report all strings set in well)

CASINO SIZE	WEIGHT, LB./FT.	DEPTH SET (MD)	HOLE SIZE	CEMENTING RECORD	AMOUNT PULLED
12"	32#	40'	16"	Ready Mix	
7"	23#	350'	9 7/8"	135 Sx Class 'G'	

29. LINER RECORD					30. TUBING RECORD		
SIZE	TOP (MD)	BOTTOM (MD)	SACKS CEMENT*	SCREEN (MD)	SIZE	DEPTH SET (MD)	PACKER SET (MD)
					2 3/8"	1482' ±	

31. PERFORATION RECORD (Interval, size and number)		32. ACID, SHOT, FRACTURE, CEMENT SQUEEZE, ETC.	
DEPTH INTERVAL (MD)	AMOUNT AND KIND OF MATERIAL USED	DEPTH INTERVAL (MD)	AMOUNT AND KIND OF MATERIAL USED

33.\* PRODUCTION  
DATE FIRST PRODUCTION PRODUCTION METHOD (Flowing, gas lift, pumping—size and type of pump) WELL STATUS (Producing or shut-in) SI

DATE OF TEST	HOURS TESTED	CHOKE SIZE	PROD'N. FOR TEST PERIOD	OIL—BBL.	GAS—MCF.	WATER—BBL.	GAS-OIL RATIO

FLOW. TUBING PRESS.	CASINO PRESSURE	CALCULATED 24-HOUR RATE	OIL—BBL.	GAS—MCF.	WATER—BBL.	OIL GRAVITY-API (CORR.)

34. DISPOSITION OF GAS (Sold, used for fuel, vented, etc.) TEST WITNESSED BY

35. LIST OF ATTACHMENTS

36. I hereby certify that the foregoing and attached information is complete and correct as determined from all available records.

SIGNED W. A. Shaw TITLE Agent

DATE 4-14-80



## INSTRUCTIONS

**General:** This form is designed for submitting a complete and correct well completion report and log on all types of lands and leases to either a Federal agency or a State agency, or both, pursuant to applicable Federal and/or State laws and regulations. Any necessary special instructions concerning the use of this form and the number of copies to be submitted, particularly with regard to local, area, or regional procedures and practices, either are shown below or will be issued by, or may be obtained from, the local Federal and/or State office. See instructions on Items 22 and 24, and 33, below regarding separate reports for separate completions.

If not filed prior to the time this summary record is submitted, copies of all currently available logs (drillers, geologists, sample and core analysis, all types electric, etc.), formation and pressure tests, and directional surveys, should be attached hereto, to the extent required by applicable Federal and/or State laws and regulations. All attachments should be listed on this form, see item 35.

**Item 4:** If there are no applicable State requirements, locations on Federal or Indian land should be described in accordance with Federal requirements. Consult local State or Federal office for specific instructions.

**Item 18:** Indicate which elevation is used as reference (where not otherwise shown) for depth measurements given in other spaces on this form and in any attachments.

**Items 22 and 24:** If this well is completed for separate production from more than one interval zone (multiple completion), so state in Item 22, and in Item 24 show the producing interval, or intervals, top(s), bottom(s) and name(s) (if any) for only the interval reported in Item 33. Submit a separate report (page) on this form, adequately identified, for each additional interval to be separately produced, showing the additional data pertinent to such interval.

**Item 29: "Sacks Cement":** Attached supplemental records for this well should show the details of any multiple stage cementing and the location of the cementing tool.

**Item 33:** Submit a separate completion report on this form for each interval to be separately produced. (See instruction for items 22 and 24 above.)

37. SUMMARY OF POROUS ZONES: SHOW ALL IMPORTANT ZONES OF POROSITY AND CONTENTS THEREOF; CORED INTERVALS; AND ALL DRILL-STEM TESTS, INCLUDING DEPTH INTERVAL TESTED, CUSHION USED, TIME TOOL OPEN, FLOWING AND SHUT-IN PRESSURES, AND RECOVERIES				38. GEOLOGIC MARKERS		
FORMATION	TOP	BOTTOM	DESCRIPTION, CONTENTS, ETC.	NAME	TOP	
					MEAS. DEPTH	TRUE VERT. DEPTH
Alluvium			Gray to buff clays, fine sands and gravels			
Lakebed Sed.			Poorly consol. coarse gravels, cobbles, clays and sand stringers			
Phyllite			Dense dark gray to black, fract. with calcite fillings		1150'	1150'

**UNITED STATES  
DEPARTMENT OF THE INTERIOR  
GEOLOGICAL SURVEY**

SUBMIT IN DUPLICATE\*

(See other In-  
structions on  
reverse side)

Form approved.  
Budget Bureau No. 42-R355.6.

**WELL COMPLETION OR RECOMPLETION REPORT AND LOG \***

1a. TYPE OF WELL: OIL WELL  GAS WELL  DRY  Other Geothermal

b. TYPE OF COMPLETION:  
NEW WELL  WORK OVER  DEEP-EN  PLUG BACK  DIFF. RESVR.  Other Temp. Obser.

2. NAME OF OPERATOR  
Getty Oil Company

3. ADDRESS OF OPERATOR  
Rt. 1, Box 197X, P. O. Box 5237, Bakersfield, CA 93388

4. LOCATION OF WELL (Report location clearly and in accordance with any State requirements)\*  
At surface 2100'S., 2275' E. of Northwest Corner of Sec. 10 - T. 27 S., R. 32 E., HB&M  
At top prod. interval reported below  
At total depth

14. PERMIT NO. AGS 133-N13320 DATE ISSUED 9-6-79

15. DATE SPUNDED 10-30-79 16. DATE T.D. REACHED 11-16-79 17. DATE COMPL. (Ready to prod.) 11-18-79 18. ELEVATIONS (DF, RKB, RT, GR, ETC.)\* 4235' + GR 19. ELEV. CASINGHEAD 4235' Mat.

20. TOTAL DEPTH, MD & TVD 1165' 21. PLUG, BACK T.D., MD & TVD 22. IF MULTIPLE COMPL., HOW MANY\* 23. INTERVALS DRILLED BY X ROTARY TOOLS CABLE TOOLS

24. PRODUCING INTERVAL(S), OF THIS COMPLETION—TOP, BOTTOM, NAME (MD AND TVD)\* 25. WAS DIRECTIONAL SURVEY MADE No

26. TYPE ELECTRIC AND OTHER LOGS RUN DIL, FDC-CNL, BHCS, Gamma-Caliper, Temperature (NG) 27. WAS WELL CORED No

28. CASING RECORD (Report all strings set in well)

CASINO SIZE	WEIGHT, LB./FT.	DEPTH SET (MD)	HOLE SIZE	CEMENTING RECORD	AMOUNT PULLED
12"	32#	40'	16"	Ready Mix	
7"	23#	348'	9-7/8"	135 SKS plus Addit.	

29. LINER RECORD

SIZE	TOP (MD)	BOTTOM (MD)	SACKS CEMENT*	SCREEN (MD)

30. TUBING RECORD

SIZE	DEPTH SET (MD)	PACKER SET (MD)
2 3/8"	1162'	

31. PERFORATION RECORD (Interval, size and number)

DEPTH INTERVAL (MD)	AMOUNT AND KIND OF MATERIAL USED

33.\* PRODUCTION

DATE FIRST PRODUCTION	PRODUCTION METHOD (Flowing, gas lift, pumping—size and type of pump)	WELL STATUS (Producing or shut-in)

DATE OF TEST	HOURS TESTED	CHOKE SIZE	PROD'N. FOR TEST PERIOD	OIL—BBL.	GAS—MCF.	WATER—BBL.	GAS-OIL RATIO

FLOW. TUBING PRESS.	CASINO PRESSURE	CALCULATED 24-HOUR RATE	OIL—BBL.	GAS—MCF.	WATER—BBL.	OIL GRAVITY-API (CORR.)

34. DISPOSITION OF GAS (Sold, used for fuel, vented, etc.) TEST WITNESSED BY

35. LIST OF ATTACHMENTS

36. I hereby certify that the foregoing and attached information is complete and correct as determined from all available records

SIGNED Wayne A. Shaw TITLE Agent DATE 12-3-79

\*(See Instructions and Spaces for Additional Data on Reverse Side)

# INSTRUCTIONS

**General:** This form is designed for submitting a complete and correct well completion report and log on all types of lands and leases to either a Federal agency or a State agency, or both, pursuant to applicable Federal and/or State laws and regulations. Any necessary special instructions concerning the use of this form and the number of copies to be submitted, particularly with regard to local, area, or regional procedures and practices, either are shown below or will be issued by, or may be obtained from, the local Federal and/or State office. See instructions on items 22 and 24, and 33, below regarding separate reports for separate completions.

If not filed prior to the time this summary record is submitted, copies of all currently available logs (drillers, geologists, sample and core analysis, all types electric, etc.), formation and pressure tests, and directional surveys, should be attached hereto, to the extent required by applicable Federal and/or State laws and regulations. All attachments should be listed on this form, see item 35.

**Item 4:** If there are no applicable State requirements, locations on Federal or Indian land should be described in accordance with Federal requirements. Consult local State or Federal office for specific instructions.

**Item 18:** Indicate which elevation is used as reference (where not otherwise shown) for depth measurements given in other spaces on this form and in any attachments.

**Items 22 and 24:** If this well is completed for separate production from more than one interval zone (multiple completion), so state in item 22, and in item 24 show the producing interval, or intervals, top(s), bottom(s) and name(s) (if any) for only the interval reported in item 33. Submit a separate report (page) on this form, adequately identified, for each additional interval to be separately produced, showing the additional data pertinent to such interval.

**Item 29: "Sacks Cement":** Attached supplemental records for this well should show the details of any multiple stage cementing and the location of the cementing tool.

**Item 33:** Submit a separate completion report on this form for each interval to be separately produced. (See instruction for items 22 and 24 above.)

### 37. SUMMARY OF POROUS ZONES:

SHOW ALL IMPORTANT ZONES OF POROSITY AND CONTENTS THEREOF; CORED INTERVALS; AND ALL DRILL-STEM TESTS, INCLUDING DEPTH INTERVAL TESTED, CUSHION USED, TIME TOOL OPEN, FLOWING AND SHUT-IN PRESSURES, AND RECOVERIES

FORMATION	TOP	BOTTOM	DESCRIPTION, CONTENTS, ETC.

### 38.

### GEOLOGIC MARKERS

NAME	TOP	
	MEAS. DEPTH	TRUE VERT. DEPTH

UNITED STATES DEPARTMENT OF THE INTERIOR GEOLOGICAL SURVEY

SUBMIT IN DUPLICATE\*

(See other instructions on reverse side)

Form approved, Budget Bureau No. 42-R355.5.

5. LEASE DESIGNATION AND SERIAL NO.

USL N-13321

6. IF INDIAN, ALLOTTEE OR TRIBAL NAME

7. UNIT AGREEMENT NAME

8. FARM OR LEASE NAME

9. WELL NO.

USL-IGH #2

10. FIELD AND POOL, OR WILDCAT

Colado Area

11. SEC., T., R., M., OR BLOCK AND SURVEY OR AREA

Sec. 10 - T.27 S. - R. 32 E., HB&M

12. COUNTY OR PARISH

Pershing

13. STATE

Nevada

WELL COMPLETION OR RECOMPLETION REPORT AND LOG \*

1a. TYPE OF WELL: OIL WELL [ ] GAS WELL [ ] DRY [ ] Other Geothermal

1b. TYPE OF COMPLETION: NEW WELL [X] WORK OVER [ ] DEEP-EN [ ] PLUG BACK [ ] DIFF. RESVR. [ ] Other Temp. Obser.

2. NAME OF OPERATOR: Getty Oil Company

3. ADDRESS OF OPERATOR: Rt. 1, Box 197X, P. O. Box 5237, Bakersfield, CA 93388

4. LOCATION OF WELL (Report location clearly and in accordance with any State requirements)\* At surface 2100'S., 2275' E. of Northwest Corner of Sec. 10 - T. 27 S., R. 32 E., HB&M At top prod. interval reported below

At total depth

14. PERMIT NO. AGS 133-N13320 DATE ISSUED 9-6-79

15. DATE SPUDDED 10-30-79 16. DATE T.D. REACHED 11-16-79 17. DATE COMPL. (Ready to prod.) 11-18-79 18. ELEVATIONS (DF, RKB, BT, CR, ETC.)\* 4235' + GR 19. ELEV. CASINGHEAD 4235' Mat.

20. TOTAL DEPTH, MD & TVD 1165' 21. PLUG, BACK T.D., MD & TVD 22. IF MULTIPLE COMPL., HOW MANY\* 23. INTERVALS DRILLED BY 24. PRODUCING INTERVAL(S), OF THIS COMPLETION—TOP, BOTTOM, NAME (MD AND TVD)\* 25. WAS DIRECTIONAL SURVEY MADE No

26. TYPE ELECTRIC AND OTHER LOGS RUN DIL, FDC-CNL, BHCS, Gamma-Caliper, Temperature (NG) 27. WAS WELL CORED No

28. CASING RECORD (Report all strings set in well)

Table with columns: CASING SIZE, WEIGHT, LB./FT., DEPTH SET (MD), HOLE SIZE, CEMENTING RECORD, AMOUNT PULLED. Rows include 12" 32# 40' 16" Ready Mix and 7" 23# 348' 9-7/8" 135 SKS plus Addit.

29. LINER RECORD

Table with columns: SIZE, TOP (MD), BOTTOM (MD), SACKS CEMENT\*, SCREEN (MD)

30. TUBING RECORD

Table with columns: SIZE, DEPTH SET (MD), PACKER SET (MD). Row: 2 3/8" 1162'

31. PERFORATION RECORD (Interval, size and number)

Empty table for perforation record.

32. ACID, SHOT, FRACTURE, CEMENT SQUEEZE, ETC.

Table with columns: DEPTH INTERVAL (MD), AMOUNT AND KIND OF MATERIAL USED

33. PRODUCTION

DATE FIRST PRODUCTION PRODUCTION METHOD (Flowing, gas lift, pumping—size and type of pump) WELL STATUS (Producing or shut-in)

Table with columns: DATE OF TEST, HOURS TESTED, CHOKER SIZE, PROD'N. FOR TEST PERIOD, OIL—BBL., GAS—MCF., WATER—BBL., GAS-OIL RATIO, FLOW, TUBING PRESS., CASING PRESSURE, CALCULATED 24-HOUR RATE, OIL—BBL., GAS—MCF., WATER—BBL., OIL GRAVITY-API (CORR.)

34. DISPOSITION OF GAS (Sold, used for fuel, vented, etc.) TEST WITNESSED BY

35. LIST OF ATTACHMENTS

36. I hereby certify that the foregoing and attached information is complete and correct as determined from all available records

SIGNED Wayne A. Shaw TITLE Agent DATE 12-3-79

\*(See Instructions and Spaces for Additional Data on Reverse Side)

UNITED STATES  
DEPARTMENT OF THE INTERIOR  
GEOLOGICAL SURVEY

SUBMIT IN DUPLICATE\*

(See other In-  
structions on  
reverse side)

Form approved  
Budget Bureau No. 42-R355.6

5. LEASE DESIGNATION AND SERIAL NO.  
USL N-13321

6. IF INDIAN, ALLOTTEE OR TRIBE NAME

7. UNIT AGREEMENT NAME

8. FARM OR LEASE NAME

USL

9. WELL NO.

USL 44X-10

10. FIELD AND POOL, OR WILDCAT

Colado Deep Test

11. SEC. T., R., M., OR BLOCK AND SURVEY OR AREA

Section 10, T27N/R32E

12. COUNTY OR PARISH  
Pershing

13. STATE  
Nevada

15. DATE SPUNDED  
3-13-81

16. DATE T.D. REACHED  
5-04-81

17. DATE COMPL. (Ready to prod.)

18. ELEVATIONS (DF, RKB, RT, GR, ETC.)\*  
RKB 4261'

19. ELEV. CASINGHEAD  
4235'

20. TOTAL DEPTH, MD & TVD  
7964' KB

21. PLUG. BACK T.D., MD & TVD

22. IF MULTIPLE COMPL., HOW MANY\*

23. INTERVALS DRILLED BY  
→

ROTARY TOOLS  
0 to 7964

CABLE TOOLS

24. PRODUCING INTERVAL(S), OF THIS COMPLETION TOP, BOTTOM, NAME (MD AND TVD)\*

25. WAS DIRECTIONAL SURVEY MADE

No

26. TYPE ELECTRIC AND OTHER LOGS RUN  
DIL, FDC-CNL, Sonic and Gamma Ray, Caliper, Temperature

27. WAS WELL CORED  
No

28. CASING RECORD (Report all strings set in well)					
CASING SIZE	WEIGHT, LB./FT.	DEPTH SET (MD)	HOLE SIZE	CEMENTING RECORD	AMOUNT PULLED
20"	94#	140'	26"	Cmt to surf. "G" Cement	-
13-3/8"	54.5	1213'	17-1/2"	Cmt to surf. "G" 1:1 Perlite 40% S.F.	-

29. LINER RECORD					30. TUBING RECORD		
SIZE	TOP (MD)	BOTTOM (MD)	SACKS CEMENT*	SCREEN (MD)	SIZE	DEPTH SET (MD)	PACKER SET (MD)

31. PERFORATION RECORD (Interval, size and number)		32. ACID, SHOT, FRACTURE, CEMENT SQUEEZE, ETC.	
		DEPTH INTERVAL (MD)	AMOUNT AND KIND OF MATERIAL USED

33. PRODUCTION							
DATE FIRST PRODUCTION		PRODUCTION METHOD (Flowing, gas lift, pumping--size and type of pump)				WELL STATUS (Producing or shut-in)	
						Shut-in	
DATE OF TEST	HOURS TESTED	CHOKE SIZE	PROD'N. FOR TEST PERIOD	OIL--BBL.	GAS--MCF.	WATER--BBL.	GAS-OIL RATIO
			→				
FLOW. TUBING PRESS.	CASING PRESSURE	CALCULATED 24-HOUR RATE	OIL. BBL.	GAS--MCF.	WATER BBL.	OIL GRAVITY-API (CORR.)	
		→					

34. DISPOSITION OF GAS (Sold, used for fuel, vented, etc.)

TEST WITNESSED BY

35. LIST OF ATTACHMENTS

36. I hereby certify that the foregoing and attached information is complete and correct as determined from all available records

SIGNED \_\_\_\_\_ TITLE Agent DATE \_\_\_\_\_

\*(See Instructions and Spaces for Additional Data on Reverse Side)

# INSTRUCTIONS

**General:** This form is designed for submitting a complete and correct well completion report and log on all types of lands and leases to either a Federal agency or a State agency, or both, pursuant to applicable Federal and/or State laws and regulations. Any necessary special instructions concerning the use of this form and the number of copies to be submitted, particularly with regard to local, area, or regional procedures and practices, either are shown below or will be issued by, or may be obtained from, the local Federal and/or State office. See instructions on items 22 and 24, and 33, below regarding separate reports for separate completions.

If not filed prior to the time this summary record is submitted, copies of all currently available logs (drillers, geologists, sample and core analysis, all types electric, etc.), formation and pressure tests, and directional surveys, should be attached hereto, to the extent required by applicable Federal and/or State laws and regulations. All attachments should be listed on this form, see item 35.

**Item 4:** If there are no applicable State requirements, locations on Federal or Indian land should be described in accordance with Federal requirements. Consult local State or Federal office for specific instructions.

**Item 18:** Indicate which elevation is used as reference (where not otherwise shown) for depth measurements given in other spaces on this form and in any attachments.

**Items 22 and 24:** If this well is completed for separate production from more than one interval zone (multiple completion), so state in item 22, and in item 24 show the producing interval, or intervals, top(s), bottom(s) and name(s) (if any) for only the interval reported in item 33. Submit a separate report (page) on this form, adequately identified, for each additional interval to be separately produced, showing the additional data pertinent to such interval.

**Item 29: "Sacks Cement":** Attached supplemental records for this well should show the details of any multiple stage cementing and the location of the cementing tool.

**Item 33:** Submit a separate completion report on this form for each interval to be separately produced. (See instruction for items 22 and 24 above.)

Data on pages 2-12

WATER							
MEASUREMENT							

**37. SUMMARY OF POROUS ZONES:**  
SHOW ALL IMPORTANT ZONES OF POROSITY AND CONTENTS THEREOF, CORED INTERVALS, AND ALL DRILL-STEM TESTS, INCLUDING DEPTH INTERVAL TESTED, CUSHION USED, TIME TOOL OPEN, FLOWING AND SHUT-IN PRESSURES, AND RECOVERIES

FORMATION	TOP	BOTTOM	DESCRIPTION, CONTENTS, ETC.
ATLANTA			...
			...
			...
			...

**38. GEOLOGIC MARKERS**

NAME	TOP	MEAS. DEPTH	TRUE VERT. DEPTH
...			
...			
...			

APPENDIX F  
DRILLING COSTS, WELL 44X-10

GETTY OIL CO.  
USL 44X-10  
SEC. 10 - T 27 N - R 32 E  
PERSHING COUNTY, NEVADA  
WELL DEPTH 7965 FT

<u>DRILLING CATEGORY</u>	<u>COST (\$)</u>
1. Location Preparation	\$ 26,299.00
2. Mobilization/Demobilization	8,927.00
3. Drilling Contractor	357,630.00
4. Drilling Mud & Chemicals	35,000.00
5. Cementing	23,505.00
6. Bits	98,200.00
7. Fuel	56,000.00
8. Equipment Rentals	76,095.00
9. Transportation	74,214.00
10. Drilling Supervision	20,000.00
11. Casing and Tubing	51,792.00
12. Wellhead	7,000.00
13. Logging & Lithology Log	116,000.00
14. Miscellaneous	<u>20,000.00</u>
TOTAL	\$970,662.00

NOTE: Does not include additional temperature logs and abandonment costs.

APPENDIX G

GEOPHYSICAL MAPS<sup>1/</sup>

ELECTRODYNE SURVEYS

Structural Interpretation Map  
Gravity and Magnetic Survey Station Location Map  
Simple Bouguer Gravity Map  
Secondary Derivative Gravity Map  
Total Magnetic's Map  
Magnetic Field Variation Map  
DC Electrical Resistivity Sounding and Profiling  
Location and Time Domain Electromagnetic Sounding Location Map  
DC Electrical Resistivity Sounding Map  
Parallel E-Field DC Electrical Resistivity Profile Map  
0.03-0.05 Hz Apparent Resistivity Reconnaissance Map  
14 Hz Normalized Apparent Resistivity Reconnaissance Map  
Anomalous Low Resistivity Value Areas (Possible Geothermal Prospects) Map  
Time Domain EM Soundings Map  
Scalar MT-AMT Vector Telluric, and Telluric Profile Location Map  
Proposed Temperature Gradient Drill Test Program Map

---

<sup>1/</sup>Available through UURI/ESL, 420 Chipota Way, Salt Lake City, UT 84108