

GL03147



ECONOMIC STUDY
OF
LOW TEMPERATURE GEOTHERMAL ENERGY
IN
LASSEN AND MODOC COUNTIES
CALIFORNIA

PREPARED FOR THE
STATE OF CALIFORNIA
DIVISION OF OIL AND GAS
AND THE
ENERGY RESOURCES
CONSERVATION AND DEVELOPMENT COMMISSION

APRIL 1977

VTN-CSL

A joint venture of VTN Consolidated, Inc. and CSL Associates, Inc.

Prepared for

STATE OF CALIFORNIA
DEPARTMENT OF CONSERVATION
DIVISION OF OIL AND GAS
AND
ENERGY RESOURCES CONSERVATION AND
DEVELOPMENT COMMISSION

ECONOMIC STUDY OF LOW
TEMPERATURE GEOTHERMAL
ENERGY IN LASSEN AND
MODOC COUNTIES, CALIFORNIA

JOB 2175-3

April, 1977

This technical study was accomplished by professional consultants under contract with the Division of Oil and Gas and project management by the Energy Resources Conservation and Development Commission, State of California through an Economic Development Administration Technical Assistance Grant. Statements, findings, conclusions, recommendations, and other data in this report are solely those of the contractor and do not necessarily reflect the view of the Division of Oil and Gas, Energy Resources Conservation and Development Commission or the Economic Development Administration.

Submitted by
VTN-CSL
A joint venture of VTN Consolidated
Inc., and CSL Associates, Inc.

TABLE OF CONTENTS

	Page
I INTRODUCTION	1
II SUMMARY AND CONCLUSIONS	2
A. Key Findings	2
B. Recommendations and Conclusions	2
III PROJECT APPROACH AND BACKGROUND DATA	4
A. Scope of Effort	4
B. Methodology Employed	6
C. Description of Study Area	6
1. General Overview	7
2. Influence Factors and other sources of energy	13
IV SELECTION OF APPLICATIONS	23
V APPLICATIONS	26
A. General	26
1. Business Considerations	26
2. Constraints	27
3. Cost of Geothermal Water Systems	27
4. Influence Factor Summary	29
B. Technical Analyses	31
1. Greenhouses	31
2. Kiln Drying	39
3. Onion Dehydration	45
4. Feedlots	51
5. Aquaculture	58
VI APPENDIX	65
A. Demographic and Economic Profile	65
B. References	86

LIST OF FIGURES

Figure No.	Title	Page
III-1	Location of major wells and hot springs	9
III-2	Major industrial sites	10
III-3	Highway and railroad map	11
III-4	Distances to major western markets	12
V-1	Contribution of energy savings to profit	26
V-2	Annual cost of supply and reinjection systems	28
V-3	Well depth vs. temperature	29
V-4	One acre quonset hut greenhouse	32
V-5	Geothermally heated greenhouses--optimum well depth	33
V-6	Investment estimations for four different greenhouses	34
V-7	Kiln drying lumber	43
V-8	Onion dehydration plant--process flow sheet	50
V-9	Single component feedlot, unit capacity 600 head, 650 pound feeder cattle	55
V-10	Combination and design feedlot for 9000 head feeder cattle	56
V-11	Geothermal heating system for 1 acre aquaculture pond	63

LIST OF TABLES

Table No.	Title	Page
III-1	Hot springs and hot-water wells in Lassen and Modoc Counties	8
III-2	Chemical constituents of thermal waters	21
IV-1	Rejected application studies	24
V-1	Summary of influence factor effects on geothermal energy applications	30
V-2	Greenhouse to average field production	31
V-3	Greenhouse product economics	38
V-4	Typical kiln drying schedules	40
V-5	Estimated extra ration energy required to compensate for each unit of cold stress	51
V-6	Estimated apparent digestibilities of ration dry matter	52
V-7	Cost Summary, 18000 head feedlot	54
V-8	Selected examples of aquacultural yields arranged by ascending intensity of culture methods	58
V-9	Stocking rates for giant fresh water prawns	61

LIST OF TABLES (continued)

Table No.	Title	Page
A-1	Historical population	65
A-2	Modoc County population by age groupings	66
A-3	Lassen County population by age groupings	67
A-4	Modoc County employment by major categories	69
A-5	Lassen County employment by major categories	70
A-6	Historical unemployment rates (%), Modoc and Lassen Counties	71
A-7	Experienced unemployed by occupation Modoc County--1972	72
A-8	Experienced unemployed by occupation Lassen County--1972	73
A-9	Family income: Lassen County and California	75
A-10	Family income: Modoc County and California	76
A-11	Lassen County: Personal income by major source	77
A-12	Modoc County: Personal income by major source	78
A-13	Agricultural production--value and rank Modoc County, California	80
A-14	Agricultural production--value Lassen County	81
A-15	Value of mineral products and timber production, Modoc County 1950-1971	82
A-16	Value of mineral products and timber production, Lassen County, 1950-1968	83
A-17	Assessed valuation of County--Assessed tangible property by class of property for Lassen County, 1940-1970	84
A-18	Assessed valuation of County--Assessed tangible property by class of property for Modoc County 1940-1970	85

I. INTRODUCTION

The Economic Study of Low Temperature Geothermal Energy in Lassen and Modoc Counties, California presented herein was authorized by the Department of Conservation, Division of Oil and Gas under Economic Development Administration Technical Assistance Grant No. 07-06-01522. Project Management has been performed by Mr. David N. Anderson, and Ms. Syd Willard of the California Energy Resources Conservation and Development Commission, Alternatives Implementation Division. Mr. Anderson was previously assigned as State Geothermal Officer, Division of Oil and Gas, during the formulation of this study contract.

The purpose of this study was to investigate the feasibility of using low cost, low temperature geothermal energy in job-producing industries to increase employment and encourage economic development. The study, encompassing all of Lassen and Modoc Counties, was to be site-specific, referencing candidate geothermal applications to known hot wells and springs as previously determined, or to new wells with specific characteristics as defined in the Scope of Work. The emphasis was to be placed on economically practical and readily achievable applications from known resources, thus complimenting the recently completed ERDA-Susanville Study where a designated community was used as a "laboratory" in which land-use planning, institutional aspects, geological assessments, technical modeling and socioeconomic impacts were all examined in overview.

During the course of the study, monthly progress reports were prepared and reviewed with the Commission so that emphasis on particular features of study could be changed as necessary to reflect updated findings and to redirect efforts into additional areas of potential promise as they became apparent. In this manner, a degree of flexibility was maintained which allowed a more comprehensive study than would have been otherwise possible.

Although the report generates both positive and negative findings in specific areas of investigation, it is felt that the overall long term prognosis for geothermal energy stimulus to industry in the area is excellent.

In addition to acknowledging indebtedness to the many investigators in the field of low temperature geothermal energy, additional thanks are due to Dr. E. Barmettler for his consulting assistance in the economics of agriculture and aquacultural applications; to several specialists at U.C. Davis who gave freely of their time, Dr. Allen Knight, Dr. Verne Mendel, Dr. Ralph Ernst, Dr. Hubert Heitman and John Dunbar; to Mr. Jim Aslette, Ray Newton and Dr. H. Adams for helping in the investigation of potato applications; to Wes Davis and Merritt Thompson for suggestions on greenhouses; to William Main and Lyle Carter for providing dry kiln information; to Roy Connors for well drilling cost data; to Fred Wieteron for information on food processing equipment; to John Robison and Kenneth Rose for background on agricultural applications in Surprise Valley; to Bill Johnson at O.I.T. for his guidance on prawn aquaculture; and especially to Judy Hannah for her work on the location and properties of geothermal springs and wells.

II. SUMMARY AND CONCLUSIONS

A. KEY FINDINGS

- Greenhouse operations in Lassen and Modoc Counties using geothermal energy can be quite competitive with conventional installations located in more favorable climatic and marketing areas. This is the most labor- and-energy-intensive of all applications studied. The dependability of geothermal energy, as compared to the interruptible nature of gas supplies for this industry, further enhances the importance of this application.
- Wood kilns involved in lumber mill operations can be operated with geothermal hot water at approximately 50% of the energy cost of fossil fuel systems. However, while bark and chips are of commercial value, more than ample low value sawdust normally is generated to fuel the kilns. The economic feasibility of employing geothermal water in kiln drying depends on the successful development of sawdust usage for other applications.
- Converting an onion drying facility from oil to all geothermal can save over one half the cost of heat energy. (The all geothermal system requires water at 240^oF.)
- Geothermally heated feed lots can furnish an assist to the economically depressed cattle industry in the area.
- The commercial economics of geothermal applications to aquaculture are not favorable under current limitations in consumer tastes, crop yield rates and growing technology.
- Space heating of commercial, residential and public buildings can be an economic and fossil energy-conserving adjunct to these process applications.
- While the use of low temperature geothermal energy can contribute to the profitability and competitiveness of many operations, the energy component of product costs in the areas of study is low. The feasibility of any given geothermal application is particularly sensitive to scale of operation, in addition to many business factors not related to the geothermal resource.

B. RECOMMENDATIONS AND CONCLUSIONS

The prospect of using low temperature geothermal water for some applications is quite promising at present and will certainly continue to grow as conventional sources of energy become more costly and scarce, and research opens new commercial options. This would appear to be particularly true for forest products and aquaculture. These subjects are discussed in some detail in the technical sections of this study.

In order to expand the nonelectrical geothermal applications for the Lassen-Modoc County area, it is felt that additional study is warranted in several areas:

- The scope of this study was specifically limited to temperatures of 212°F or below. Since the study area, particularly in the Wendel-Amedee and Surprise Valley areas, contains demonstrated resources at much higher temperatures which still may be unsuitable for producing electrical power, the definition of "Low Temperature" should be extended to about 350°F. Many processes excluded from this study, such as canning, sugar beet and potato processing, and refrigeration could have then been considered.
- Establish a demonstration project encompassing a geothermally heated feedlot to obtain empirical data and participation of local ranchers. Several ranchers interviewed expressed interest in this concept. The possibilities of a cooperative should be evaluated.
- Establish a demonstration project for geothermal energy to be used in conjunction with exciting new advances in hydroponically grown cattle feeds and other agricultural products. The geothermal energy would control both the atmosphere in the greenhouse and the temperature of the nutritive liquids.
- Establish demonstration projects for geothermal dehydration of onions, and garlic. A trade organization presently exists and their cooperation should be solicited.
- Investigate the possibility of establishing a high density multi-use geothermal industrial park, thus minimizing shared cost of capitalized assets such as wells and distribution systems and incorporating efficiencies of cascaded and clustered construction. Survey and identify specific companies who would be interested in participating. An ideal list of participants would include users with approximately equal thermal loads, each of which would extract its heat over a different temperature range. Such a list might include cascaded use by a refrigeration plant, a food processing plant, a greenhouse and a heated feed lot extracting heat at 270-300°F, 240-270°F, 210-240°F and 140-210°F respectively.

III. PROJECT APPROACH AND BACKGROUND DATA

This section describes the scope of work covered in the report and the methods of analysis used to collect and interpret data. A brief description of the Lassen and Modoc County study area is provided and several factors which influence the application of geothermal energy are discussed.

A. SCOPE OF EFFORT

A summary of the Scope of Work as defined by the Division of Oil and Gas and presented in the study is outlined below.

1. Purpose

The purpose of the study is to provide usable data on the potential utilization of geothermal resources in specific job-producing industries which could be used to increase employment and encourage economic development. Its aim is to show whether use of low-cost geothermal energy can reduce the cost of producing goods; and if factual information on how and where this can be done is provided to potential producers, developers, and investors, to see if new business can be attracted and new jobs created.

The study's purpose is to analyze several specific industries that can utilize low temperature geothermal energy to reduce product cost, to estimate the magnitude of potential competitive advantages to the industries, and to publish those analyses and back-up data. State and local agencies will subsequently distribute the published information. In addition, the State will provide a six month follow-up program to bring potential users into direct contact with geothermal operations.

2. Assumptions and Considerations

- a. Geothermal resources exist in quantities at usable temperatures in several separate localities of Lassen and Modoc counties.
- b. Shallow geothermal reservoirs can be explored, drilled and tested and found to be productive at rates which will allow commercial development.
- c. Use of geothermal water warmer than 212°F or boiling at the altitude of occurrence will not be considered. Temperatures above 212°F will undoubtedly be found during the exploration and exploitation of hot springs complexes and during exploration for deep high temperature reservoirs for power generation. This constraint was made in order to make it easier for the individual, "back-yard" user. If the temperature is above boiling, additional precautions would have to be taken by the well driller and operator of the resource.
- d. A geothermal well with the following characteristics will be developable.

Well: 300-foot deep, production 260 gpm (1,000 liters per minute) or greater, 6" casing.

Pump: Capacity of 260 gpm (1,000 liters per minute)
Discharge pressure of 25 psi or greater.

- e. Used geothermal waters shall be reinjected into the ground via a well.

3. Work Plan

- a. Review published and unpublished data provided by the Division of Oil and Gas and other sources, and rank the thermal springs and wells in Lassen and Modoc counties by temperature.
- b. Develop a candidate list of ten products or processes from the following four categories. The candidate processes should be chosen for their potential direct use of hot water energy within the specified temperature ranges.
- Controlled environmental (greenhouse) growing of agricultural products.
 - Livestock production.
 - Food processing and storage.
 - Manufacturing.
- c. The Division of Oil and Gas, in consultation with the contractor, will at the end of the first month of operation select five of these products or processes for intensive study.
- d. For each product or process, an analysis shall be prepared showing production costs using conventional energy (fuel oil, electricity or other appropriate fuel), and production costs utilizing geothermal energy to a maximum. Process flow diagrams shall be developed and complete ready-for-market costs shall be determined for both conventional production and production utilizing geothermal energy. Current wholesale prices for similar goods shall be determined for nearby market areas.

Each analysis should consider the variation of the product price to the various water temperature ranges. Additional heat may be necessary from conventional fuels in order to achieve temperature for certain processes or to meet seasonal or peaking requirements.

Changes in temperature ranges would affect these requirements and production costs.

Each analysis should consider the following factors plus other items where appropriate. Each factor should be discussed as to its economic influence on total production cost:

- Climate
- Fresh Water Requirements
- Shipping
- Marketing
- Labor
- Terrain
- Environmental Considerations
- Research
- Quality of Geothermal Fluids
- Multi-Use
- Quality of Product
- Temperature Enhancement (Process Requirement)
- Peaking Temperature (Weather Requirement)
- Uninterruptable Supply

B. METHODOLOGY EMPLOYED

Data for this report was collected in cooperation with the State Energy Commission and through use of their reference materials. Field trips were made to Lassen and Modoc Counties. Geothermal hot springs and well sites were visited. A geologist familiar with the area was retained to consult on location and to characterize the resources. Local officials, land owners and businessmen were interviewed to determine the degree of local interest in use of geothermal energy for existing and proposed businesses.

An agricultural economist consultant provided assistance in evaluating agriculture and agricultural applications. This was bolstered by consultation with experts in specific fields of application at U.C. Davis. Personnel in private business operations in food processing and wood kiln drying were contacted, as were manufacturers of equipment. They provided technical guidance and extended our list of reference literature.

Engineering heat and material balances and analyses of influence factors were accomplished using conventional techniques, and these were incorporated in the economic analyses. Recommendations and conclusions based on these findings are presented in the summary, part II.

C. DESCRIPTION OF THE STUDY AREA

The study covers five geothermally active areas in Northeastern California: the Susanville, Wendel-Amedee and Big Valley areas in Lassen County and the Surprise

Valley and Pit River areas in Modoc County. These areas are on the east slopes of the junction of the Sierra and Cascade Mountains. The areas are typified by forested mountains in the west and high (4,000-foot elevation), semi-arid range land and intervening mountains of the basin and range province.

The economy of both counties is heavily dependent on forest products, agriculture and ranching. Lassen County also supports a large segment of its population through government employment at the Sierra Army Ordnance Depot and at the California Conservation Center, a State Prison.

The areas have been classified by the U.S. Department of Commerce as economically depressed. In some areas employment is highly seasonal with unemployment figures as high as 25 percent. Appendix A provides a demographic and economic profile of the counties, including data on population, population trends, unemployment history, work skills, agricultural and manufacturing production and assessed property valuations.

1. General Overview

Lassen County, population about 18,000, and Modoc County, population about 6,000, are characterized by small, scattered communities. Susanville, with a population of about 7,000, and Alturas, with a population of approximately 3,000, are the only incorporated cities and major population centers in Lassen and Modoc Counties, respectively.

Geothermal springs and wells are also scattered throughout the counties. The flow rates depths and temperatures are reproduced from reference 2 in Table III-1 and their locations are shown on the map in Figure III-1.

Geothermally heated greenhouses are located at Susanville and at Wendel Hot Springs. Lumber is the major industry of the area. Coin Lumber and Eagle Lake Lumber companies are located in Susanville and heat their kilns by burning wood waste products. Main Industries located near Bieber heats its kiln by burning number 2 fuel oil.

Figure III-2 illustrates the locations of the greenhouses and lumber companies.

Federal Route 395, the major north-south road, services Reno, Susanville and Alturas. See Figure III-3. Adequate secondary roads are available over the mountains to the west and northwest. Southern Pacific Railroad service is also available from Reno to Susanville and Alturas, and a branch line extends east from Alturas through Homestead Siding where it crosses the Burlington Northern line.

Further south, the Burlington Northern line intersects the Western Pacific tracks so that transshipment is available to all major west coast cities. Another branch of Southern Pacific track, between Susanville and Westwood where it meets Western Pacific, is currently inoperative so that rail traffic from Susanville to the west must detour north through Alturas or south through Reno.

Reno is the only major market area less than 100 miles from the geothermal areas. The relative distances between these areas and other major markets in California, Oregon, Nevada and Idaho are illustrated in Figure III-4.

TABLE III-1
HOT SPRINGS AND HOT-WATER WELLS
IN
NORTHERN CALIFORNIA

No.	Name of Spring or Well	Location	Temp		Flow (l/min)
			(°C)	(°F)	
(A) Surprise Valley					
(1)	Peterson's Ranch	SE1/4,NW1/4,Sec. 8,T.46N.,R.16E.	36-42	97-108	400
(2)	Bucher's well	SW1/4,SE1/4,Sec. 8,T.46N.,R.16E.	36	97	8,300*
(3)	Ft. Bidwell well	NW1/4,NE1/4,Sec. 17,T.46N.,R.16E.	37	99	600
(4)	Lake City mud volcano and hot springs	Sec. 24,T.44N.,R.15E.	48-97	118-207	400
(5)	Wells (to 1,368 m)	near Lake City	160	320	N.A.
(6)	Hutchen's well (124 m)	SW1/4,NE1/4,Sec. 20,T.43N.,R.16E.	48	118	9,460*
(7)	Well (194 m)	SW1/4,NW1/4,Sec. 20,T.43N.,R.16E.	69	156	570*
(8)	Robison's well (77 m)	NE1/4,SW1/4,Sec.30,T.43N.,R.16E.	50	122	605*
(9)	Seyferth Hot Springs	NW1/4,NW1/4,Sec. 12,T.43N.,R.16E.	85	185	500
(10)	Leonard Hot Springs (west)	NW1/4,NE1/4,Sec. 13,T.43N.,R.17E.	65	149	200
(11)	Leonard Hot Springs (east)	NE1/4,NE1/4,Sec. 13,T.43N.,R.17E.	62	144	150
(12)	Hot Spring	NW1/4,SE1/4,Sec. 6,T.42N.,R.17E.	95	203	N.A.
(13)	Hot Springs Hotel wells	NE1/4,SW1/4,Sec. 6,T.42N.,R.17E.	84-98	183-208	300
(14)	Hot Springs Hotel springs	SE1/4,SW1/4,Sec. 6,T.42N.,R.17E.	50-54	122-129	1,800
(15)	Benmac Hot Springs	SW1/4,SW1/4,Sec. 6,T.42N.,R.17E.	96-97	205-207	750
(16)	Menlo Hot Springs	NE1/4,NE1/4,Sec. 7,T.39N.,R.17E.	57	135	1,000
(17)	Squaw Bath	NE1/4,NW1/4,Sec. 29,T.38N.,R.17E.	49	120	450
(B) Alturas Area					
(18)	Hot Creek Ranch	SE1/4,Sec.9,T.42N.,R.11E.	33	91	500
(19)	Kelly Hot Spring	NE1/4,Sec. 29,T.42N.,R.10E.	92	198	1,200
(20)	Well** (977 m)	Sec. 29,T.42N.,R.10E.	110	230	N.A.
(21)	New William's Ranch well (62m)	SE1/4,SW1/4,Sec. 30,T.40N.,R.13E.	29	84	150
(22)	Old William's Ranch well	SW1/4,NW1/4,Sec. 31,T.40N.,R.13E.	44	111	150
(23)	West Valley Res. Hot Spring	SW1/4,NE1/4,Sec.29,T.39N.,R.14E.	74	165	1
(C) Big Valley and Little Hot Spring Valley					
(24)	Bassett Hot Spring	NW1/4,SE1/4,Sec.12,T.38N.,R.7E.	79	174	200
(25)	Kellog Hot Spring	SW1/4,SE1/4,Sec.15,T.38N.,R.8E.	78	172	15
(26)	Little Hot Springs	NW1/4,SW1/4,Sec. 9,T.39N.,R.5E.	75-77	167-171	300
(D) Susanville					
(27)	Roosevelt Swimming Pool well (37 m)	NE1/4,NE1/4,Sec. 6,T.29N.,R.12E.	36	97	N.A.
(28)	L.D.S. Church well (181 m)	SW1/4,NW1/4,Sec. 5,T.29N.,R.12E.	49	120	N.A.
(29)	Miller's Custom Work well	NE1/4,NW1/4,Sec. 5,T.29N.,R.12E.	48	118	N.A.
(E) Wendel-Amedee					
(30)	Wendel Hot Springs	SW1/4,SE1/4,Sec. 23,T.29N.,R.15E.	96	205	1,200
(31)	Well (189 m)	Sec. 23,T.29N.,R.15E.	64	147	N.A.
(32)	Amedee Hot Springs	NW1/4,NE1/4,Sec. 8,T.28N.,R.16E.	95	203	500
(33)	Wells (to 334 m)	Sec. 4 and Sec. 8, T.28N.,R.16E.	107	225	N.A.
(34)	Doyle Hot Spring**	SE1/4,NW1/4,Sec. 24,T.24N.,R.12E.	42	108	500

*Temperature and flow measured during pump test.
**Not located on maps.
N.A.—Not available.

Reference: Report No. TR 13 Division of Oil & Gas

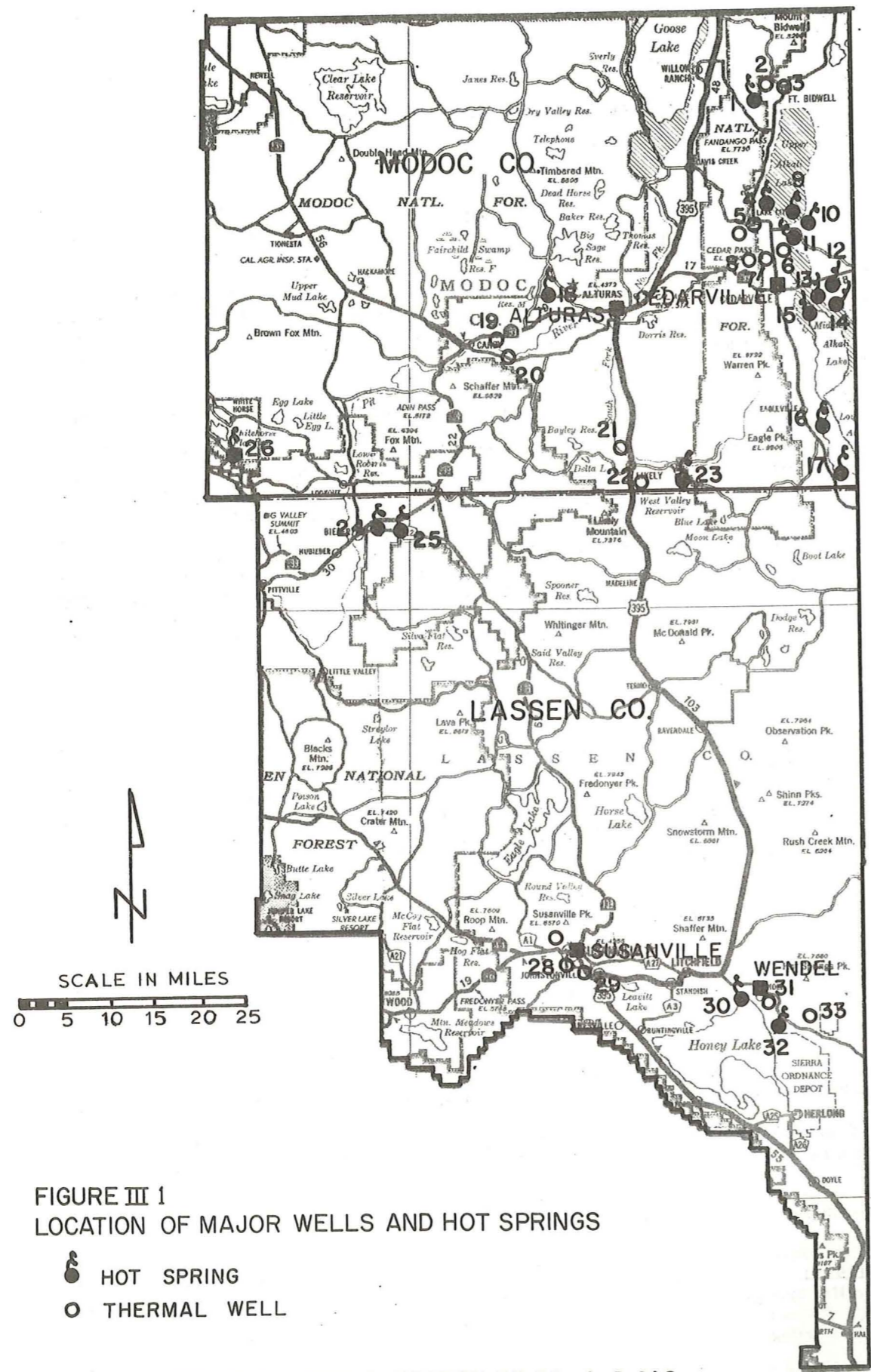

FIGURE III 1
LOCATION OF MAJOR WELLS AND HOT SPRINGS

- HOT SPRING
- THERMAL WELL

SOURCE: STATE OF CALIFORNIA, DIVISION OF OIL AND GAS
TECHNICAL REPORT 15

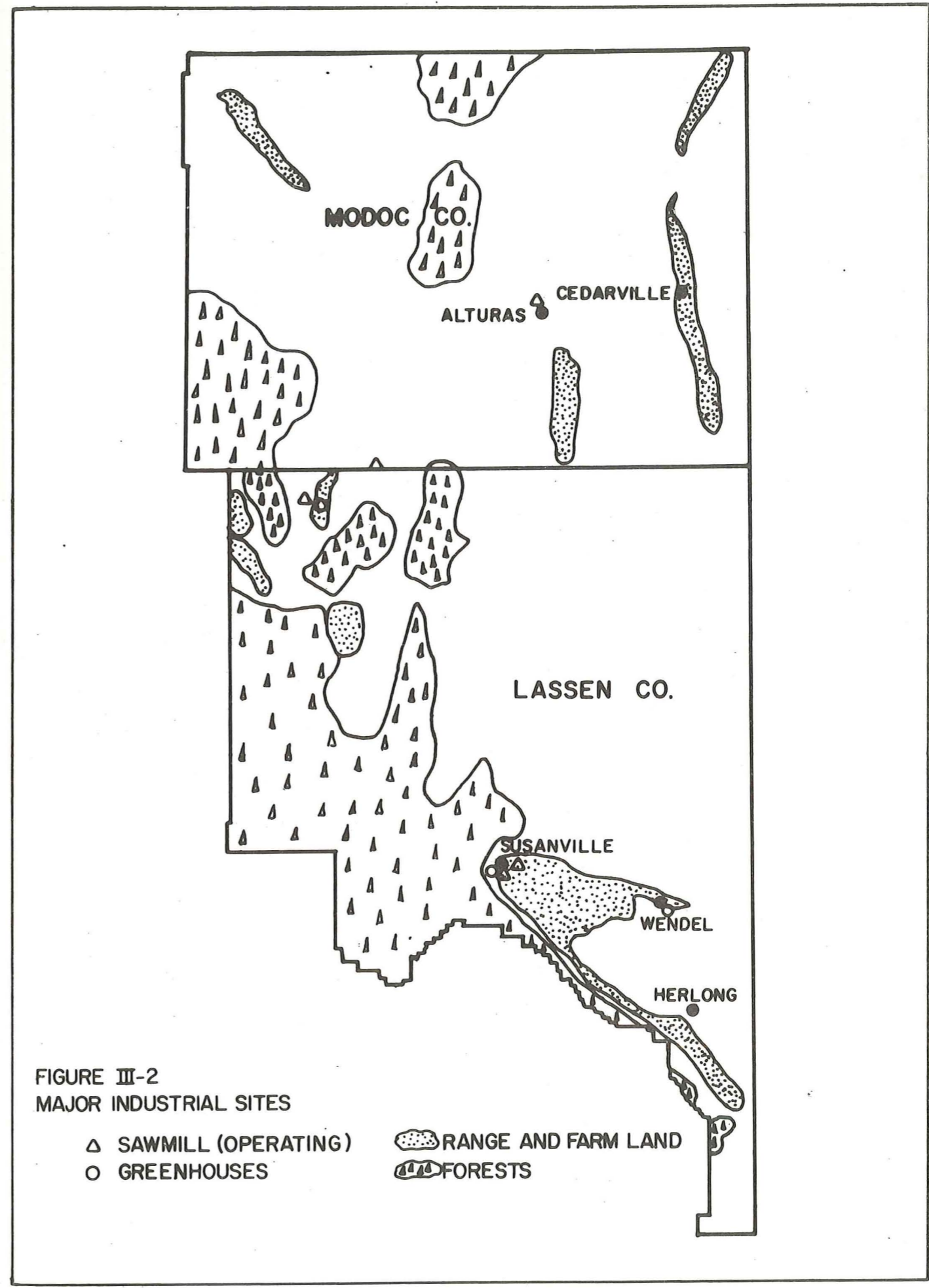

FIGURE III-2
MAJOR INDUSTRIAL SITES

- △ SAWMILL (OPERATING)
- GREENHOUSES
- ▨ RANGE AND FARM LAND
- ▲ FORESTS

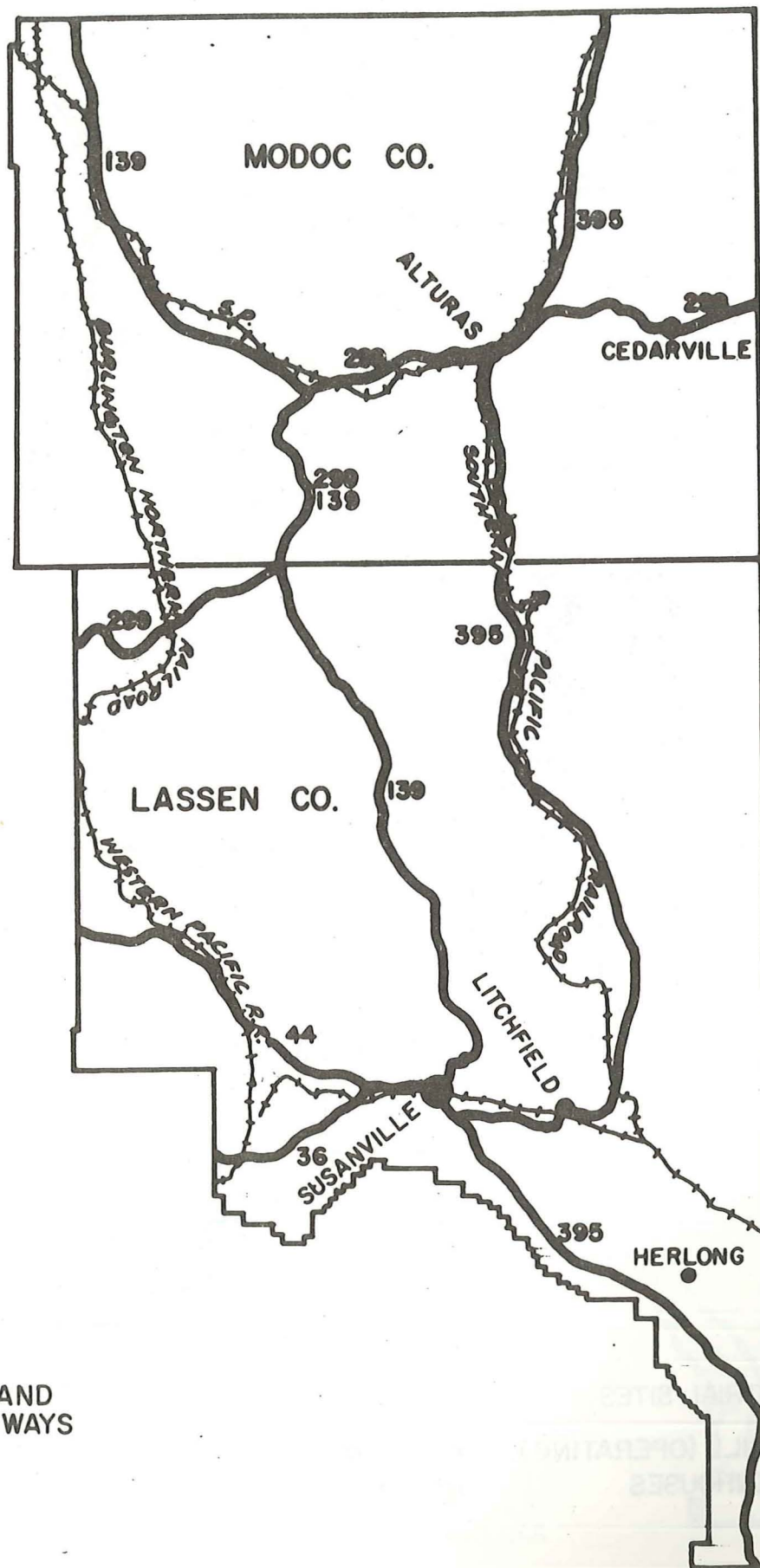

FIGURE III-3
RAILROADS AND
MAJOR HIGHWAYS

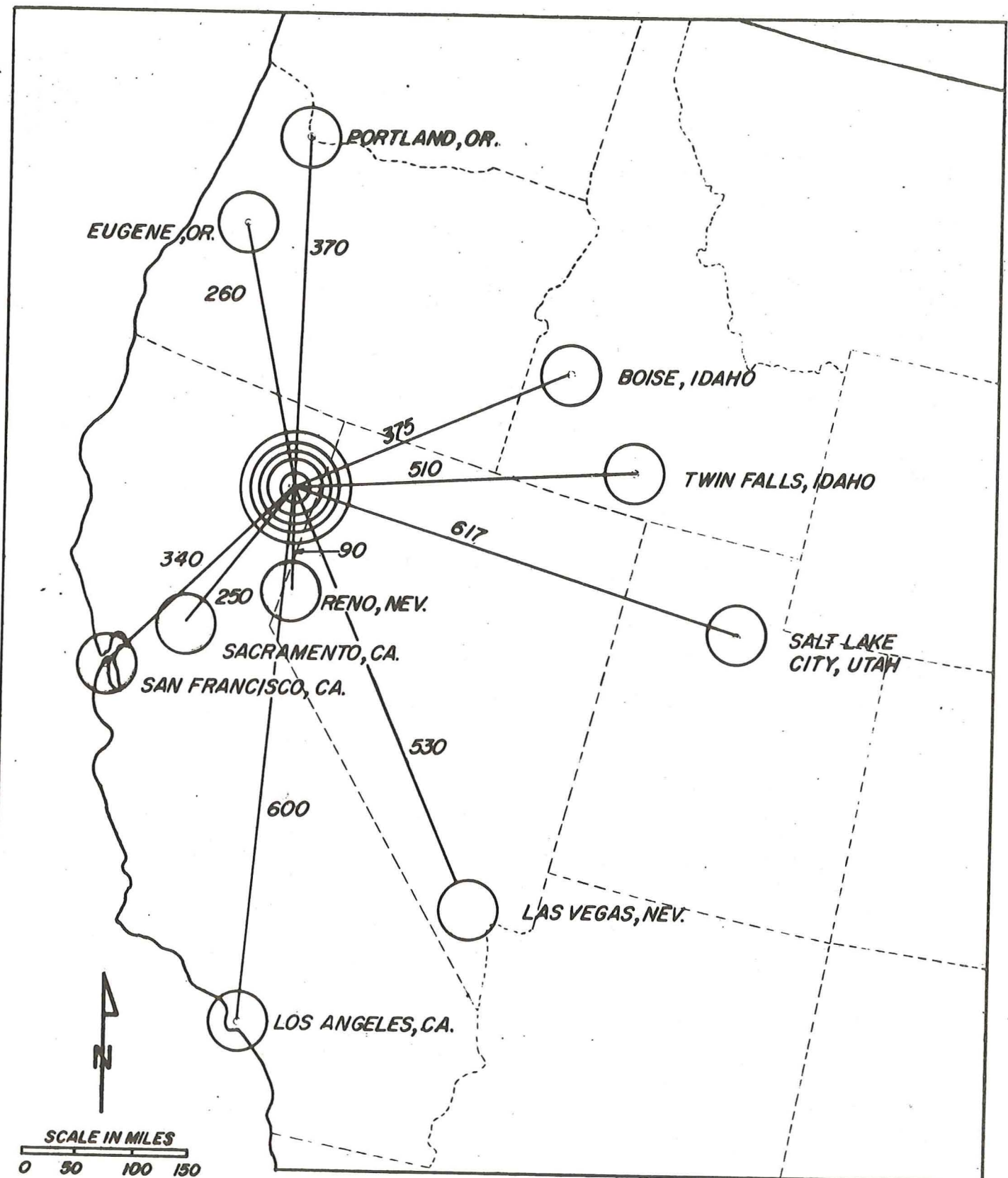

FIGURE III 4
DISTANCE TO MAJOR WESTERN MARKETS (APPROXIMATE IN ROAD MILES FROM
MODOC AND LASSEN COUNTIES)

2. Influence Factors and Other Sources of Energy

Of the 14 influence factors, several can be discussed as generalizations covering all the applications, while others are quite specific to each. This section provides a general discussion for the area in relation to the influence factors shown on page 31.

a. Climate

Climatic summaries for the principal geothermal areas in Modoc and Lassen Counties are provided in the appendix. All three areas have similar climates, with Alturas slightly colder than Cedarville and Susanville. Growing seasons are short, indicative of the severe climate of the region. Length of the mean growing season between the last spring occurrence of 32°F and the first fall occurrence of 32°F ranges between 82 and 131 days for Alturas and Cedarville, respectively. Freezing temperatures have occurred in all months of record for each station. Rainfall is moderate to low, averaging between 12 and 15 inches for these stations.

b. Fresh Water Supply

Presented below is an evaluation of the availability of water supplies in the several geothermal areas of Modoc and Lassen Counties for industrial uses. Potable groundwater occurs in Surprise Valley, Pit River Valley (near Alturas), Big Valley and Honey Lake Valley. For all practical purposes industrial water supplies will either be developed from local groundwater or purchased from community systems. This section provides a brief evaluation of the availability of groundwater in the study area.

SURPRISE VALLEY

Surprise Valley is a closed elongated valley, 50 miles long by about 12 miles wide. Since the valley has no surface outlet, saline intermittent lakes have formed throughout most of its length in the central, lower elevation areas of the basin. Groundwater occurs along the alluvial bajada of Warner Mountains to the west, and appears near the surface in many lower elevation areas. In many places along this western flank, the piezometric surface of confined aquifers is above the surface. Near most of the communities good areas exist for groundwater development, although there are certain areas with poor water quality--many created by mixing and pollution by thermal springs.

The principal water-bearing formations are the near-shore deposits, which occur as highly permeable terraces, beaches, spits and deltas formed in ancient Surprise Lake. Recent valley sediments include alluvial fans, intermediate alluvium and basin deposits. Alluvial fans may reach thicknesses of greater than 1000 feet in the western flanks of the valley. These fans are the principal aquifers of the region.

Water quality is highly variable, ranging from potable quality waters to inferior quality water satisfactory for industrial use only. The latter waters are associated with areas of thermal artesian waters. Water in the study region is far superior in dissolved solids and potentially troublesome constituents than geothermal water in the Imperial Valley.

Evaluation of groundwater availability and quality is site dependent in the valley. Consequently, further determination of available water supplies can be made only after siting of the industrial plant is made. Generally, however, ample, good quality groundwater is available throughout most of the valley.

PIT RIVER VALLEY

The Alturas Groundwater Basin, near Alturas and within the Pit River Valley, has a complex geologic history. Prior to the late Miocene uplift which produced the Warner Mountains, the area was occupied by a broad valley, with a large interior lake. This valley received sediments from the adjacent mountains, now composing a portion of the lower member of the Alturas Formation. During the Pliocene and early Pleistocene periods, volcanic eruptions deposited a variety of materials in the basin. Subsequent quiescent periods were followed by formation of a second large lake. Contemporaneous and subsequent faulting, folding and erosion formed the present Alturas Basin.

Principal groundwater zones are (1) Plio-Pleistocene and Pleistocene Lava Flows, and (2) Alturas Formation. Other zones where groundwater occurs include near-shore deposits of the ancient lakes and Recent, although thin, valley sediments. The Alturas Formation is the major zone of groundwater development. The formation consists of moderately consolidated, flat-lying beds of tuff, ashy sandstone, diatomite and basalt. Buried lava flows in the Alturas Formation may account for a large proportion of water yielded to wells. Substantial volumes of groundwater have been estimated to exist in storage in this basin. Water quality is generally good and suitable for more beneficial uses. However, in large areas in the Warm Springs Valley subbasin, groundwaters have excessive sodium absorption ratios and are considered hazardous for irrigation use.

BIG VALLEY

Big Valley is situated in the southwestern corner of Modoc County, extending into the northwestern corner of Lassen County. Principal water bearing formations in the region are Pliocene to Pleistocene Lava Flows, the Bieber Formation (lake deposits, sands, silts and clays) and recent valley sediments. Lavas in the basin consist of jointed and fractured basalt, and are generally moderately to highly permeable. These lavas exist in irregular patterns, and are limiting from groundwater development except as they are encountered in the Bieber Formation. The Bieber Formation is estimated to reach thicknesses of at least 1000 feet, and in areas may be as great as 2000 feet. Principal aquifers in the formation are beds of white pumiceous sand and black volcanic sand.

Recent valley sediments include basin deposits and alluvium. Basin deposits are low in permeability and do not yield much water to wells. Alluvial fans occur only in a few areas. Both these deposits are unimportant from a water supply standpoint in the basin; however, local areas may yield moderate supplies of water. The intermediate alluvium consists of deposits of about 200 feet in thickness. Where found in sufficient thickness, these materials may yield large quantities of water to wells. Most wells developed in the Big Valley Basin yielded between 190 and 900 gpm, with significant drawdown, indicating a specific capacity and low permeability. Competing uses include present irrigation demands. Groundwater in this basin is generally excellent in quality and suitable for most uses.

SUSANVILLE AND WENDEL-AMEDEE

The sediments which comprise the Honey Lake Valley Basin are relatively deep and contain a substantial volume of groundwater. Sediments have been derived from erosional products of the surrounding mountains and volcanic intrusions of basalt and other materials. Deposition of coarser materials has occurred near the point of departure of streams from the mountains with gradation of finer materials down-gradient finally associating with the clays and fine silts and salts of lake environments. Over the 500 square mile extent of the Honey Lake Valley groundwater basin saturated sediments are 10-750 feet thick containing an estimated storage of 16,000,000 acre feet. Recharge occurs from channel percolation, bank overflow and direct precipitation infiltration in the higher elevations, especially on highly fractured and jointed basaltic rocks in the upper Susan River system.

Apparently, under normal conditions the Susan River in the valley area east of Susanville is an effluent stream, i.e., the river receives its base flow from groundwater. The basin generally acts as a free water table, but in places some confining zones exist. Flowing wells located along the southwestern flanks of the Diamond Mountains tap confined aquifers in the lower portions of alluvial fans and adjoining shore deposits. Springs in Honey Lake Valley are divided into three groups: those which issue from jointed or fractured rock (generally volcanics), thermal springs issuing from deeper origins along or near faults, and those which issue at the intersection of groundwater with the ground surface.

Groundwater quality varies throughout the area, generally becoming poorer in the lower portions of the basin, especially near Honey Lake. Near Hot Springs, groundwater is generally more highly mineralized. In these areas excessive fluoride, arsenic, and boron are sometimes present.

c. Markets and Shipping

Most applications for geothermal energy, to be commercially economical, require relatively large scale operation and sizeable markets. The reasons for this are tied both to the normal business activities and to incorporation of geothermal energy. Business activities tend to optimize for large operations because labor can be used more efficiently, more mechanization is affordable, overhead can be spread more effectively, and marketing and shipping can take advantage of reduced costs. Geothermal energy is also more effectively used by a large enterprise because the cost of drilling and distributing the water is high and the quantity of energy available even from a single well is normally far in excess of that which a small business can efficiently absorb.

Distances from Susanville and Alturas to some selected major markets are listed below. (See Figure III-4 page 12):

Market	MARKET DISTANCES	
	Distance From Susanville (miles)	Distance From Alturas (miles)
Reno, Nevada	80	188
Sacramento, California	229	337
San Francisco, California	318	426
Eugene, Oregon	435	290

Truck routes to the markets are adequate and kept open most of the year. Costs of transportation by truck in California, including loading and unloading, run in the range 0.15 to 0.45 cents per pound per 100 miles for a wide range of products. Costs for shipment by rail average 2.1 cents per ton mile. This equates to about 0.1 cent per pound per 100 miles. When all other factors are essentially equal, i.e., capital, labor costs, taxes, etc., location of a business enterprise near a geothermal area becomes economical when the savings in energy exceeds the added cost for transportation of supplies and produce. As will be seen in the text, the savings in cost of energy does, in fact, exceed transportation costs for several of the selected products.

d. Labor Supply

The major source of labor in Lassen County is Susanville, which has an unemployment rate greater than 20 percent peak and 17 percent annual average. Unemployment is highly seasonal, with wide swings between high summer and low winter employment. Over 50 percent of the employment is through government jobs and per-family income is about 75 percent of the state average.

Modoc County unemployment also fluctuates widely, from 17.3 percent in January to 8.8 percent in May 1976.

Appendix A provides descriptive material and Tables which define specific skills of the labor force.

e. Environmental Considerations

The development of a geothermal energy supported industry in Modoc and Lassen Counties would lead to certain environmental impacts. These impacts can be divided into those which would be caused by the geothermal energy system and by those which would be caused by the remaining elements of the industrial plant. Industrial applications that have been considered in this study are those that would utilize energy from geothermal waters through closed heat transfer systems. The geothermal fluid cycle proposed is a one-pass system-extraction, energy conversion and re-injection. Under operations of this nature, impacts of importance are those related to geophysical and hydrological considerations. Air quality impacts would not be a consideration, since the energy systems proposed would be closed to the atmosphere. An examination of the potential geothermal energy cycle environmental impacts is provided.

Environmental impacts from the geothermal energy system may occur during drilling, site development and utilization stages. Initial impacts from drilling and site development can arise from land surface disturbances (hydrographic and ecologic disturbances). Site-related impacts that may be most important in Modoc and Lassen Counties are possible critical habitat and archaeological disturbances, if development sites are not wisely located. Surface water and air quality impacts during drilling and site development will be light, both related to brush removal and baring of the land surface (erosion and dust problems), which will be small in scale relative to other natural factors.

Critical wildlife habitat in the region includes (1) sage grouse strutting grounds, (2) antelope kidding grounds, (3) deer and antelope wintering areas,

and (4) habitats for critical rare and endangered species including marten, wolverine and fisher. Careful planning programs can help to mitigate most potential impacts of this nature.

Geothermal energy utilization systems proposed are one-pass, closed systems (extraction, heat transfer and re-injection). Impacts of possible concern are those associated from fluid extraction and re-injection processes to the reservoir, and transit through potable groundwater aquifers. The possible causes of these types of impacts are related to the following:

- Pressure Changes in the Hydrothermal System
- Rock/Sediment Internal Stress Changes
- Tectonic Readjustments
- Erosion/Abrasion of Producing Components
- Dissolution of Conforming Rocks and Sediments
- Precipitation of Solutes
- Water Quality and Balance Alterations

Impacts that are often addressed to withdrawal and injection of geothermal fluids are: (1) induced seismicity, (2) land deformation, and (3) shallow groundwater quality degradation.

The methods proposed for utilization of geothermal energy are non-consumptive, meaning that depletion of the fluid would not occur. Therefore, what is extracted from a point "A" is re-injected at some point "B", theoretically located such that the injected water does not adversely affect the hydrothermal reservoir system. If this closed system has hydraulic continuity, land deformation would not occur, and in all practicality, seismic effects also would not be anticipated. However, if the location of points A and B are not directly linked hydraulically, and differential hydrostatic pressure responses occur, localized deformation may occur at the zone of extraction (i.e., recharge to the zone of extraction is less than the withdrawal rate). If re-injection must take place at high pressures, seismic considerations become very important. A discussion on subsidence is provided in the following section. However, since low temperature geothermal wells are generally shallow (less than 1,500 feet), and in unconsolidated basins, seismic considerations would normally be minimal.

INDUSTRIAL APPLICATIONS

Development of new industry in Modoc and Lassen Counties will create a variety of effects. Most will be beneficial, such as providing new jobs and income in economically depressed areas; however, with every action of man there are some adverse environmental effects. The purpose of this brief section is to address the various types of adverse environmental impacts that may occur with new industrial activities as studied in this report. Mitigation of principal impacts has also been addressed.

Greenhouses:

Environmental impacts that may be associated with greenhouses are much the same as any agricultural activity. Land is required, fertilizers and pesticides are applied, crop wastes must be disposed of, water for irrigation is necessary, and materials for construction are required. Each greenhouse may differ from another. Crops may be planted in native soil, or in closed hydroponic furrows with gravel, or other sub-base materials. In one case, infiltration into the ground may occur, and in the other, little or no infiltration would result. These types of impacts are localized, and do not emerge until many years after, in the form of localized groundwater degradation--true of most agricultural areas of the world.

Plant residue wastes after cropping are disposed of in conventional manners. Secondary recovery of these wastes can be possible through composting and/or pyrolytic conversion.

Aquaculture

The controlled growth of aquatic animals in geothermally heated ponds will cause certain localized environmental impacts. Land is required, substantial water is necessary, occasional odors may result, and possible water pollution may occur.

Cattle Feeding

Cattle feedlots may cause substantial adverse impacts if improperly constructed and maintained. In this case, considerable land is required, odors and air quality (hydrocarbons) degradation may occur, and water pollution may be severe, due to the concentration of several thousand animals. Waste conversion and/or disposal of manure is also a significant consideration.

Onion Dehydration

Adverse impacts that may be associated with onion dehydration plants include land requirements, possible odor problems, and necessary waste disposal.

Kiln Dry Lumber

Existing drying units would be converted to utilize geothermal energy. No new impacts would occur outside of minor construction-related considerations.

SUBSIDENCE CONSIDERATIONS

Subsidence, the lowering of the land surface, can be caused by sub-surface extractions of water accompanied by a pressure decline. Saturated sediments, and some rocks, are supported in part by the water matrix. When this fluid support is removed, the over-burden sediment weight may be sufficient to cause compression of the formation voided of fluid. Whether compression occurs or not, and to what extent, is dependent upon (1) the compressive strength of the formation, and (2) absolute pressure head decline that occurs.

There have been many subsidence occurrences of significant extent in groundwater, oil and geothermal production fields. In groundwater and geothermal

fields (Wairakei, New Zealand), subsidence has been associated with lowering of the water-table and compaction of unconsolidated sediments after removal of large volumes of water. Lateral deformation may also result due to induced steep hydraulic gradients (Lofgren, 1974).

Subsidence in groundwater basins where substantial fluid has been withdrawn, such as the San Joaquin Valley, have reached declines of 29 feet. In Wairakei, New Zealand, where large amounts of geothermal fluids have been withdrawn without re-injection of the waste stream to the reservoir, up to 30 feet of subsidence has occurred, effecting more than 25 square miles, with the maximum subsidence occurring beyond the production fields.

When the water-table is not lowered and the producing formation is competent, i.e., it will resist compression from the weight of overlying formations after pore water is removed, subsidence will not occur.

It appears that in Laderello, Italy and The Geysers, the host steam formation is competent, since no or only very slight subsidence has occurred during more than 60 years of operation at the former, and more than 16 years of operation at the latter.

In the Susanville-Honey Lake Valley region, the producing geothermal reservoir proposed for development is situated above bedrock in andesite, a zone of hypothesized high porosity and permeability roughly 3,000 feet of andesite are overlain by confining lacustrine deposits consisting of clay zones and unconsolidated alluvium deposits.

Extraction of fluids from the lower portions of the andesitic formation might not cause subsidence even with depletion of the water source and lowering of the producing zone pressure head (Zebal, 1976).

The hypothesis that subsidence will not occur is based upon the competency of the andesite to withstand strain deformation under actual overburden loads. Operations for geothermal energy conversion systems investigated in this project would involve extraction and reinjection to the host formation, but sufficiently distant from the producing reservoir so as not to cool (degrade) the reservoir, yet close enough to provide for recharge continuity to the area of the reservoir.

Another consideration when monitoring of subsidence is to be undertaken, is the relative effect of other groundwater pumping in the locality (for irrigation, etc.).

Since local groundwater production in the region has been increasing, it is probable that with further removal of groundwater and lowering of water tables, some subsidence will occur in several areas if it has not already.

Subsidence associated with valley-wide shallow groundwater pumping and deep geothermal fluid extraction may be indistinguishable from one another without elaborate monitoring systems. How the two subsiding zones would interact is comparison to shallow groundwater volumes extracted. The relationship between the relative amounts of extracted volumes from the reservoirs and subsidence is not known. Assuming that subsidence occurs in direct proportion to the volume of fluids extracted, the subsidence resulting from geothermal fluids, if such should occur, would probably be small in relationship to that which may occur from groundwater pumping for irrigation.

Surface changes may also result from deep-seated tectonic re-adjustments triggered by stress changes (Lofgren, 1974).

GROUNDWATER DEGRADATION

Improperly specified materials in geothermal wells may lead to casing leaks, and degradation of surrounding potable groundwater supplies. Quality deterioration would be related to temperature gain, increase in total dissolved solids, and the trace elements--boron, fluoride and arsenic. Proper selection of materials and proper construction methods would normally minimize this type of impact. Areas of concern are those where potable groundwater reservoirs overlie deep hydrothermal systems.

f. Quality of Geothermal Fluid

The chemical constituents typical of geothermal water in the areas are shown in Table III-2.

In some wells (samples 1 and 4 in Honey Lake Valley) the water is of high quality and appears to meet the Interim Primary Drinking Water Standards of the U.S. Public Health Service, part of which require dissolved solids to be less than 1000 mg per liter, boron less than 1 mg per liter, and fluorine less than 1.4 mg per liter. Most samples, however, do not meet requirements for human consumption.

Of the five applications for geothermal energy analyzed in this report, four include products for human consumption. Existing public rules governing use of water for this purpose deal mostly with water re-use and disinfection and were not designed for geothermal water. For lack of specific directives, and based on warnings of the potential dangers of concentration of toxic compounds in various plants and organisms by agricultural experts, application of geothermal in this report covers only indirect use for heat in closed piping systems. Heat is extracted from the water through pipe walls without direct contact with the end use product. In one case, this imposes a considerable economic penalty--aquaculture of prawns. Currently, data is being collected through experiments with prawns grown directly in geothermal water⁵ at Oregon Institute of Technology, but the quality of the water there is very good (230 ppm).

Another concern in use of geothermal water is corrosion and deposition of solids. For most chemicals (calcium sulfate being a notable exception) the solubility increases with temperature. The geothermal waters tend to saturate at the higher temperatures and to precipitate the excess salt as they cool through the process equipment. Calcium is well below its saturation level, and other constituents are in sufficiently low concentrations, that deposition does not appear to be a major concern. Of 11 samples tested⁵ in Honey Lake and Surprise Valley, the pH was above 7.0 (neutral) in all cases and averaged 8.1 (mildly alkaline). The pH range is ideally suited for low cost materials of construction, i.e., steel asbestos (pipe) with minimum corrosion. That corrosion and scaling are not insuperable impediments to direct geothermal fluid use can be proven by current usage of geothermal water to heat a swimming pool and a greenhouse in Susanville, a second greenhouse near Wendel-Amedee, and to space heat several buildings on the Oregon Institute of Technology (OIT) Campus.

TABLE III-2

LASSEN COUNTY

Chemical Constituents of Thermal Waters, Honey Lake Valley (in mg/l)

Sample Number	Location	Li	Na	K	Rb	Mg	Ca	Zn	F	Cl	HCO ₃	CO ₃	SO ₄	SiO ₂	B	Calculated Dissolved Solids
1	NE/NE Sec. 6	<0.01	20	3.8	<0.01	3.4	19	0.043	<0.1	2.0	120	1	11	53	<0.02	233
2	SE/NE Sec. 6	0.05	140	4.6	0.02	1.6	24	0.009	1.2	64	68	1	190	62	1.4	558
3	SW/SE Sec. 23	0.12	280	7.5	0.04	<0.1	18	0.015	4.1	190	50	1	360	120	5.5	1,040
4	NE/SW Sec. 30	0.01	58	8.0	0.01	2.2	6.0	<0.005	0.2	17	112	1	32	42	0.22	279
5	NW/NE Sec. 8	0.08	250	5.5	0.02	<0.1	14	<0.005	4.4	160	44	2	300	95	4.0	879

MODOC COUNTY

Chemical Constituents of Thermal Waters, Surprise Valley (in mg/l)

Sample Number	Location	Li	Na	K	Rb	Mg	Ca	Mn	Zn	F	Cl	HCO ₃	CO ₃	SO ₄	SiO ₂	B	Calculated Dissolved Solids
1	NW/NE Sec. 17	0.03	110	9.5	0.01	0.1	4.2	<0.01	<0.005	2.2	31	131	1	86	82	0.61	458
2	SW/NE Sec. 24	0.24	320	15	0.08	<0.1	7.7	<0.01	<0.005	7.6	220	112	0	320	200	6.3	1,210
3	NW/NW Sec. 12	0.15	300	9.0	0.04	<0.1	28	0.01	<0.005	5.4	220	63	0	370	110	7.6	1,110
4	NE/NE Sec. 13	0.13	330	8.5	0.03	0.6	26	0.09	<0.005	5.2	220	82	1	390	110	7.6	1,180
5	NE/SW Sec. 6	0.10	280	5.5	0.03	<0.1	16	<0.01	0.014	5.1	200	57	2	320	100	5.7	991
6	NE/NE Sec. 7	<0.02	100	1.4	<0.01	<0.1	5.1	<0.01	<0.05	3.8	25	27	34	120	53	0.93	370

Chemical Constituents of Thermal Waters, Modoc Plateau (in mg/l)

Sample Number	Location	Li	Na	K	Rb	Mg	Ca	Mn	F	Cl	HCO ₃	CO ₃	SO ₄	SiO ₂	B	Calculated Dissolved Solids
1	NE/NW Sec. 29	0.15	250	6.5	0.02	<0.1	20	<0.01	2.1	160	45	1	300	110	3.8	899
2	SW/NW Sec. 31	<0.01	49	3.4	<0.01	<0.1	4.2	<0.01	0.4	11	80	3	28	52	0.22	231
3	NW/SW Sec. 9	0.17	230	5.2	0.02	0.2	44	0.01	1.9	120	49	0	400	87	3.9	941
4	NW/NE Sec. 29	0.40	330	11	0.06	<0.1	19	0.012	4.0	150	63	0	510	130	4.5	1,220
5	NW/SE Sec. 12	0.10	220	3.2	0.01	<0.1	30	<0.01	2.0	93	30	1	370	68	2.5	820
6	SW/SE Sec. 15	0.12	240	5.9	0.02	<0.1	30	<0.01	2.6	110	31	2	370	85	3.2	880
7	NW/SW Sec. 25	0.12	300	4.3	0.02	<0.1	52	<0.01	3.6	140	49	6	520	47	12.8	1,130

Constituents Below Detection:

Cs < 0.1
 Fe < 0.06
 Cd < 0.01
 Co < 0.05
 Cu < 0.02
 Ni < 0.04
 Pb < 0.1
 Zn < 0.005

¹ Chemical analyses by L. M. Willey, T. S. Presser, J. B. Rapp, and M. J. Reed.

Data from DOG Report No. TR15, Chemistry of Thermal Water in Selected Geothermal Areas of California, by Marshall J. Reed

OIT²⁷ is currently running corrosive tests on various specimens located above at the waterline and immersed in geothermal well water.

Generally, water under 100°C will not deposit silicates, and high chloride content will enhance corrosion of carbon steels²⁸. It is difficult to predict corrosivity, however, based on simple chemical analyses. Work at Reykjavik, Iceland, indicated that corrosion rates of geothermal waters with similar chemical analyses could vary widely. Reasons for the variation are not understood. Pending specific corrosion data for the study areas, it has been assumed that common materials of construction in current use will suffice.

g. Multi-Use

Multi-use can be made practical where several users are clustered together in an industrial park. Residual energy in the water discharge from a high temperature system can be consumed by downstream low temperature users. A food processing plant could discharge its water to a greenhouse which might in turn discharge to a space heating system, to a feed lot heating system or to a fish pond.

Multi-use requires fewer wells and provides the most efficient use of the geothermal resource but a penalty must be paid in the cost of user equipment. Because it places the users in series, designs must include by-passes, cold water mixing controls and/or automatic throttling controls to prevent upstream process fluctuations from causing temperature changes in water fed to downstream users. Also because the thermal driving force is less, the heat exchangers in the downstream applications must be larger. Multi-use is economical when the savings in wells and distribution systems exceed the added user equipment costs.

h. Other Sources of Energy

The four principal sources of energy which are available within the study area are electrical power, LPG, fuel oil and wood. There is no natural gas available, and accordingly, the cost of energy is high.

Electrical power for Lassen and Modoc counties appears to be ample for the present but it is subject to periodic winter blackouts, the transmission and switching problems occur. Neither county generates its own power. Lassen County is supplied by R.E.A. and Pacific Gas and Electric Company. It is distributed by California Pacific Utility and by the Plumas Sierra Rural Electric Company. Since Plumas Sierra is a cooperative chartered under the R.E.A., its customers enjoy a significant rate advantage of the private utility customers. This is due to the fact that C.P.U. must purchase bulk power from P.G. and E., while Plumas Sierra uses Bureau of Reclamation, Feather River or Bonneville power, "wheeled" over P.G. and E. transmission lines at a modest cost. Modoc County is served by Pacific Power and Light and Surprise Valley Electrification Corporation.

Fuel oil is a second source of energy, and is consumed in boilers in large facilities such as the Conservation Center near Susanville and for general space heating. LPG is also used for space heating primarily in rural areas.

Due to the high cost of other energy sources, a considerable amount of wood is consumed for residential and industrial purposes. Both Eagle Lake Lumber Company and Coin Lumber Company produce all of their process steam from sawdust and planing chips. In addition, the Eagle Lake Lumber Company has some 6,000 KW of electrical generating capacity.

IV. SELECTION OF APPLICATIONS

In evaluating job potentials of various applications this study analyzed several energy intensive industries that could utilize inexpensive geothermal energy to reduce product costs, and estimated the magnitude of potential competitive advantages. Selection of the candidate applications was achieved in conjunction with field trips to the geothermal areas, interviews with local entrepreneurs and owners of wells, and discussion of details of business operations with experts in the field--both at universities and in business operations. Because the major employment businesses endemic to Lassen and Modoc counties are cattle ranching, agriculture and lumbering, the field of applications was initially narrowed to ten which appeared to fit these categories.

They were:

- Solid vegetables (in greenhouses)
- Medicinal Plants (in greenhouses)
- Ornamental Plants (in greenhouses)
- Fish Ponds
- Algae Ponds
- Cattle feeding
- Potato Processing
- Onion Dehydration
- Garlic Dehydration
- Timber (kiln) Drying

On further detailed analysis of potato processing it was determined that while substantial savings would accrue by use of high temperature geothermal water up to 350° F, only insignificant savings (0.1-0.2 cents per pound) could be attained through use of water at less than 212° F.

POTATO PROCESSING

<u>Process</u>	<u>Temperature °F</u>	<u>BTU/lb Product</u>	<u>*Heat Cost ¢/lb Product</u>	<u>Use of Low Temperature Geothermal Energy</u>
Peeling	180	875	.23	Yes
Blanching	180	1250	.33	Yes
Cooking	212	1000	.27	No
Flakes	350	8409	2.23	No
Flour	350	8409	2.23	No
Granulating	550	5500	1.47	No
Slices	230	7500	2.00	No

*Use of gas (efficiency 60%)

As a consequence, potato processing was deleted and onion dehydration substituted.

It will also be of interest to note several applications which were considered and rejected as being less practical than those selected. Table IV-1 lists these reasons for discontinuing study.

TABLE IV-1

REJECTED APPLICATION STUDIES

<u>Application</u>	<u>Reason for Rejection</u>
1. Medicinal Plants (Greenhouse)	Lack of Economical Data
2. Poultry	Fuel costs per bird are not a significant cost factor, i.e., 0.43 cents per pound.
3. Swine	Industry concentrated in east where grain, molasses and hominy are available. Young need environmental control but problems with adults are associated with too much heat rather than too little.
4. Catfish	Lack of proven market in western U.S.A. Failure rate is 75 percent among new businesses.
5. Carp	Easy to grow at high densities but considered an inferior food fish by the American public.
6. Singel Celled Protein	Most concentrated protein source and great future potential potential but development of market too uncertain for purposes of this report.

One application of low temperature geothermal energy which has received insufficient attention and which needs more study in future geothermal energy studies is space heating. Where shallow wells or springs are available immediately adjacent to a home, installing a simple economical piping system can be made to supplement or replace the normal home heating systems. One rancher in the Surprise Valley area is in the process of doing just this. Also in this same locale, the Mineral Springs Motel (currently old and in disrepair) at one time heated its buildings and its large swimming pool using an adjacent spring. Its new owner is considering renovating and rebuilding the geothermal heating systems. The Susanville Geothermal Energy Project Study analyzed geothermal utilities for distributing hot water over long distances to agricultural and industrial users. The economics of the system were sensitive to the spacing of the users and the use quantities. With current fossil fuel prices, use of such a utility to heat individual homes in small towns would be uneconomical. Larger buildings spaced reasonably close to each other appear to be more practical. In Klamath Falls, more than 1,000,000 square feet of buildings spread over the campus of Oregon Institute of Technology are geothermally heated. The Presbyterian Intercommunity Hospital (96,000 square feet) has added geothermal space heating to assure an uninterruptable energy supply, and space heating for several churches is under consideration. It is also of interest that geothermal water can be feasibly transported long distances with only moderate losses in temperature.

The economics of space heating using geothermal water and long distance transportation are two subjects that should be investigated more thoroughly. However, due to the lack of job intensity and dispersion of potential users, space heating was discarded as being unpromising for this particular study.

The final selection of applications and the reasons for their selection are as follows:

- Greenhouses--solid vegetables, ornamentals
- Cattle Feeding
- Timber Drying
- Aquaculture-Shrimp (*Macrobrachium rosenbergii*)
- Onion Dehydration

Greenhousing is an obvious selection. The sciences of greenhouse design, heating requirements, control of crop pests, crop nourishment and marketing are all well known factors. The cost of heating is very similar for wide varieties of crops. This enables comparison of many agricultural applications with a minimum of analysis. In addition, moderate scale geothermal heating of greenhouses has been practiced in Lassen County for several years.

Cattle feeding was selected because cattle ranching is endemic to the two counties. In Modoc County, where surplus alfalfa is available, cattle are sometimes wintered; but in Lassen County they are shipped out for winter to warmer areas. Because of weak market conditions, cattle ranching is currently in a recession. If geothermal energy could promote wintering in the counties and add to the normal weight gain of the animals, it might contribute to the ability of the ranchers to ride out the recession.

The timber industry is also endemic to both counties and is the only major industry located there. It is highly energy intensive and is a major employer.

Timber drying was selected because it is practiced by the major lumbering corporations and by the smaller sawmills, and because it can be accomplished using low temperature geothermal energy.

Like greenhouses, aquaculture ponds can be used for a wide variety of products, and pond heating analyses can be applied to a wide variety of marine and fresh-water organisms. The major obstacle in this study area is the palate of the American public, unaccustomed to consumption of warm water fish such as Talapia and Carp. A large well developed market does exist for shrimp and prawns, however. Market prices are an order of magnitude higher than for the warm water fish. Of the species of this delicacy food available, the Asian fresh water prawn, *Macrobrachium rosenbergii*, is generally conceded to be the most adaptable for controlled breeding, and a large reservoir of research and practical experience is available from Hawaii, Japan, U.C. Davis and the Marine Resources Research Institute in Charleston, S.C.

Onion dehydration was selected because of the large quantities of low temperature energy consumed in the process and the existence of a major onion producing area in northwest Modoc County and the Tule Lake area.

V. APPLICATIONS

This section discusses general factors which apply to all the applications and provides an analysis of each application.

A. GENERAL

1. Business Considerations

To appreciate the use of geothermal energy, its costs relative to alternative forms of energy, its effect on profit and its impact relative to other business considerations should be understood.

Costs of geothermal energy are low compared to most other energy sources. The low temperature aquifers lie relatively near the surface so that well drilling expenses are nominal. Energy required for pumping the geothermal water will normally consume only one to two percent of the total energy available in it. Depending on the degree of utilization, the cost of low temperature geothermal energy can range anywhere from \$.30 per million BTU to \$2 per million BTU. This compares to alternate energy sources such as electricity, \$6 to \$12, oil about \$3.50, natural gas, \$1.50 and propane about \$5.00 per million BTU.

In many cases the savings in energy after allowing for added transportation costs is only a small percentage of the per unit market selling price. Despite this, one should not infer that energy savings in such a situation could not contribute substantially to profit. Consider as an example a product which after all expenses yields a normal profit of 15 percent. Figure V-1 illustrates the increase in percent of profit from energy savings. It will be noted that in a case where the energy savings for a 50 cent product is only 2 cents, it can effect a 27 percent increase in profit (see dashed line).

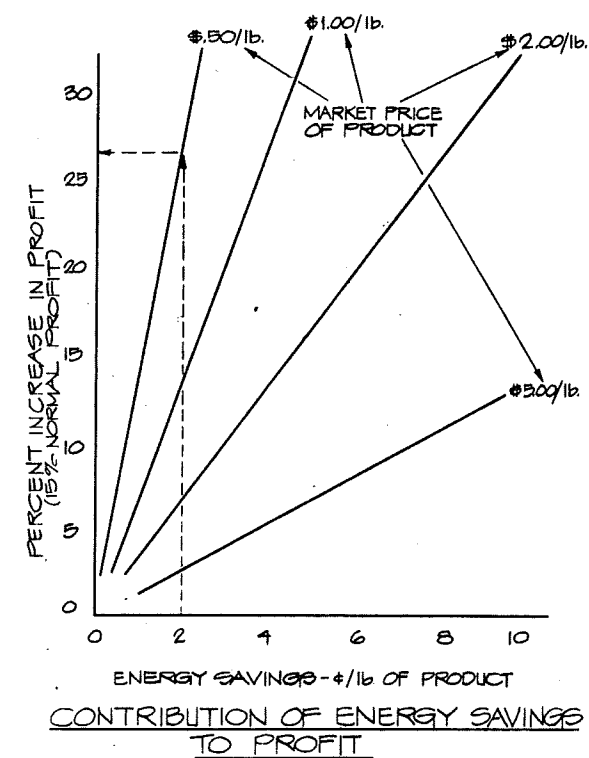

FIG. V-1

Energy savings through use of geothermal energy can increase the overall efficiency of a process. More important considerations in starting a new business, however, are market price of the product, market stability and capital requirements, financing and management skills. When all the basic elements for a business are favorable, then the secondary impact considerations which boost efficiency can be considered. The mere presence of geothermal energy does not justify an adventure into business. Rather the combination of a favorable business climate, bolstered by this potentially competitive energy source, can provide an advantageous competitive edge.

2. Constraints

The constraints imposed on preparation of this report include a requirement to limit applications to temperatures below the normal boiling point of the geothermal waters at the location in which it is found, about 204°F for most locations in Modoc and Lassen Counties. This temperature limit adds a requirement for additional high temperature energy sources for onion drying and for some species of wood in kiln drying. It must not be overlooked, however, that water is available in the area at temperatures to 320°F. Use of this higher temperature could provide all the needs of these processes and open up a host of new potential applications, including potato and sugar beet processing, fruit dehydration, refrigeration plants, freeze drying plants, water distillation plants and others.

3. Cost of Geothermal Water Systems

This report deals with a wide variety of products. Similar geothermal water supply and disposal systems will be required by all the applications. This section describes the systems and establishes their costs.

From the criteria outlined in Section II, each well produces 260 gpm through a six-inch casing. To provide the same kind of consistent treatment to the supply and disposal systems, it was assumed that each well would be located 500 feet from the process equipment and that each reinjection well would be located 1000 feet away. Costs were based on casing the entire length of both the supply and reinjection wells. It was also assumed that all systems would require 100 psi pump pressure to meet system pressure drop needs. Real requirements would of course vary; but since pumping power costs were small compared to total costs, the error introduced by the assumption is minor.

Water analyses in the areas showed it to be alkaline and to contain only dilute concentrations of salts. As a consequence, it appeared that estimates based on carbon steel construction of pumps and asbestos cement for pipes would be practical.

A well driller in the study area described well and pump costs as follows:

WELL DRILLING COSTS

Drilling Cost	\$1 per inch of diameter/foot of depth (double for rock)
Casing Cost	\$7 per foot for 6-inch pipe
Perforation Cost	\$1.50/foot
Pump, motor w/ starter, 260 gpm 20 h.p.	\$4,000
Surface Sanitary Seal	\$200

Cost of asbestos cement pipe installed four feet below grade runs about five dollars per foot. To be conservative, it has been assumed that half the well passes through rock, that the perforated length is 50 feet and that the reinjection well is identical to the source well. Based on these considerations and assuming interest of nine percent, 10-year straight line depreciation, and 30 mill per KW power at a mean usage of 25 percent of peak power, capital costs and annual operating costs for a 260 gpm supply and reinjection well system were calculated as follows:

$$\begin{aligned} \text{Capital Cost (\$)} &= 32 D + 14700 \\ \text{Annual Operating Cost (\$)} &= 4.87 D + 2870 \end{aligned}$$

Where D is the depth of the supply well in feet.

By combining this data with estimated depths vs. temperature of wells shown in Figure V-3, a curve of annual cost vs. well depth and temperature may be prepared as indicated in Figure V-2. A shaded area is shown to provide for uncertainties in local prices of equipment, labor and power. The mean costs from this curve are used in the cost analyses of the various applications for the low temperature geothermal energy.

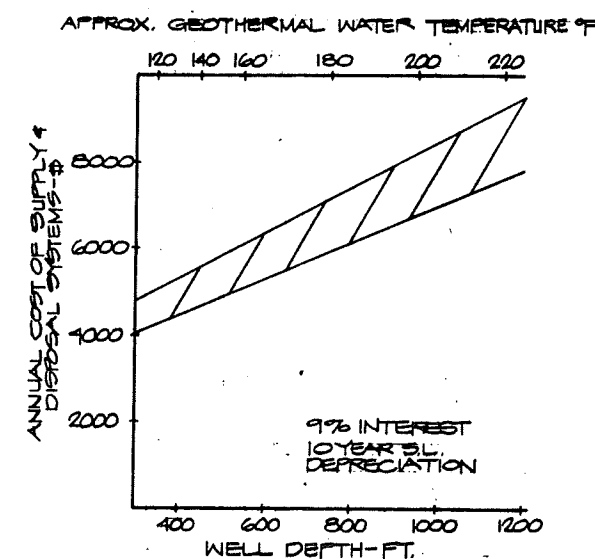

ANNUAL COST OF SUPPLY & REINJECTION SYSTEMS
CAPACITY 260 GPM

FIG. V-2

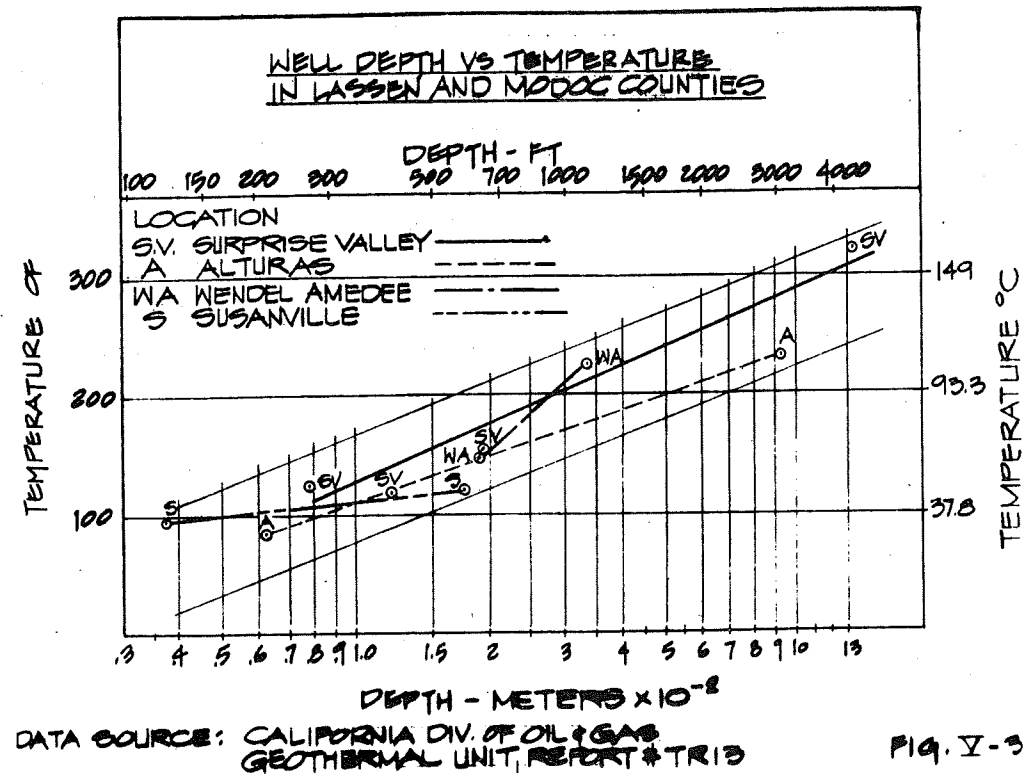

FIG. V-3

In determining the value to be used for the depth, D, a review of literature describing the actual resources indicated that the figure of 300 feet provided in the scope should be modified. When well data from TR-15² was rearranged in order of decreasing temperatures, the following list was obtained.

Location and Name of Spring or Well	Depth Ft.	Temperature °F
1. Well near Lake City *(S.V.)	4890	320
2. Well (Alturas)	3205	230
3. Well (W.A.)	1096	225
4. Well (S.V.)	636	156
5. Well (W.A.)	620	147
6. Robinson's Well (S.V.)	252	122
7. L.D.S. Church Well (Sus)	594	120
8. Hutchen's Well	407	118
9. Roosevelt Swimming Pool (Alturas)	121	97
10. New Williams Ranch Well (Alturas)	203	84

*S.V. - Surprise Valley, W.A. - Wendel Amedee, Sus - Susanville

It may be noted that only three wells have temperatures greater than 212°F and have depths greatly exceeding the 300 feet. The highest temperature was 122°F. Obviously, the guideline depth was too shallow. To arrive at a more practical guideline, a graph of log depth temperature was plotted as indicated in Figure V-3. This curve provides a weighted average of the available data, and is used estimating the cost of wells for economic analyses in this report.

4. Influence Factor Summary

Influence factors which are of particular importance to the applications are discussed in the text. A summary of each factor effect is illustrated in Table V-1.

TABLE V-1
SUMMARY OF INFLUENCE FACTOR
EFFECTS ON GEOTHERMAL ENERGY APPLICATIONS

Influence Factor	Greenhousing	Kiln Drying Lumber	Feed Lots	Onion Dehydration	Aquaculture
Climate	Major factor in use of energy.	Negligible factor	Major factor in use of energy.	Negligible factor	Major factor in use of energy.
Fresh Water Requirements	Less than 1/10 of field grown crops.	Negligible factor	Negligible factor	Negligible factor	Requires about one well per acre of pond in cold weather.
Shipping	Truck or railway south to Reno. Energy savings exceed trucking costs.	Existing industry. Established shipping costs not affected.	Added production compensates for additional cost of shipping feed.	Dehydrator reduces weight by a factor of 6 - 7 and saves shipping costs.	A negligible factor. Shipping cost less than 1% of market price. Negligible factor.
Marketing	Existing; markets during off-season of field grown product. Higher market price, better quality.	Existing industry, not a factor.	Coop feed lot could put profit from this element of marketing into pockets of hard pressed ranchers.	Would not alter product quality. Could influence new industry in area.	Current market price cannot cover cost of geothermal energy, but long-term potential is good.
Labor	Most labor effective of applications. A 10 acre facility would need 30 - 50 personnel.	No direct change in labor requirements between old & geothermal method of drying.	18,000 head per year production requires 10 - 15 persons.	800 - 1000 acres of onion land plus dehydrator plant would require several hundred persons.	Labor is 30 to 40% of grow-out cost.
Terrain	Can be installed on hillsides but no lack of flat land in area.	Flat terrain preferred	Flat terrain preferred	Flat terrain preferred	Flat or gently sloping terrain preferred.
Environmental Considerations	No change to existing systems except reinjection of geothermal water.	No change to existing systems except reinjection of geothermal water.	No change to existing systems except reinjection of geothermal water.	Some odor from drying operations. Locate away and down wind of inhabited area.	Reinjection of geothermal water. Fresh water overflow is clean enough to support fish.
Research	Not required	Not required	Optimized spacing and sizing of underground pipe in particular soils.	Not required	Testing to determine if aquatic animals can be grown directly in particular samples of geothermal water.
Quality of Geothermal Field	All systems involve closed pipes. Only potential problem is corrosion and scaling. General high pH of geothermal waters in Lassen and Modoc Counties will prevent corrosion. Low solids will minimize scaling.				
Multi-use	Can be located downstream of kiln drying.	Discharges high temperature water suitable for further use by greenhouse feed lot or aquaculture but economic advantage is small.	Can be located downstream of kiln drying.	Marginal	Current profits too low to pay for required heat exchange, but long-term potential excellent.
Quality of Product	Not affected by geothermal energy.	Not affected by geothermal energy.	Cattle gain more weight in heated feed lot when outdoor temperatures are low.	Not affected by geothermal heat.	Heating allows maintenance of ideal temperature - higher yields.
Temperature Enhancements (process requirement)	Not a factor	Required for some species of wood.	Not a factor	Water must be heated from 212°F (study limit) to 240°F for 1st stage drying.	Not a factor
Peaking Temperature (weather requirement)	Extended periods of extreme cold could require peaking.	Not a factor	Not a factor	Not a factor	Extended periods of extreme cold could require peaking.
Uninterruptable Supply	Loss of heat source could result in catastrophic crop loss.	Temporary delay in production.	Loss in production efficiency.	Temporary delay in production.	Loss of heat source could result in catastrophic crop loss.

B. TECHNICAL ANALYSES

1. Greenhouses--Productivity

Recent experiments in agricultural techniques in growing of crops in greenhouses may portend immense advances in more efficient food production. The use of controlled environment (carbon dioxide, humidity and light) and other high density growing techniques provide yields which, in the words of one expert, "will become a major factor in alleviating world food shortages and at the same time improve our economy and environment." As proof he cites the production advantages of greenhouse grown crops over field crops as illustrated in Table V-2. Another source¹¹ claims selling prices (in England) are 10 to 100 times the price of field crops. Even small changes in environmental control can greatly affect production. A change in temperature of only 1°C¹¹ could alter the return on crops by 1000 pounds (about 17 percent) per acre. Other tests indicated that control of carbon dioxide at three times ambient concentration could increase tomato yields by 40 percent.

TABLE V-2

Greenhouse Ratio to Average--Field Production per Year:

Vegetables	Greenhouse to Average-Field	Greenhouse Production	Field Production
Carrots	6 to 1	80 tons	14 tons
Cucumbers	96 to 1	450 tons	3.73 tons
Lettuce, Bibb	30 to 1	17,500 cartons of 2 Doz. Heads	583 cartons
Bell Peppers	5 to 1	22.5 tons	4.5 tons
Chili Peppers	5 to 1	12 tons	2.4 tons
Radishes	18 to 1	300,000 Bunches	16,666 Bunches
Squash	3 to 1	24 tons	8 tons
Tomatoes	15 to 1	196 tons	13 tons
Watermelon	4 to 1	10 tons	2.5 tons

October 1976 Solar Engineering

In addition to large increases in productivity, greenhouses have the added advantages of being adaptable to land which would otherwise be unsuitable for agriculture, and requiring an order of magnitude less of water than field crops. Use of geothermal energy for heating provides yet an additional advantage--making feasible a year-round production of a large variety of crops which could not otherwise be economically produced in the study areas.

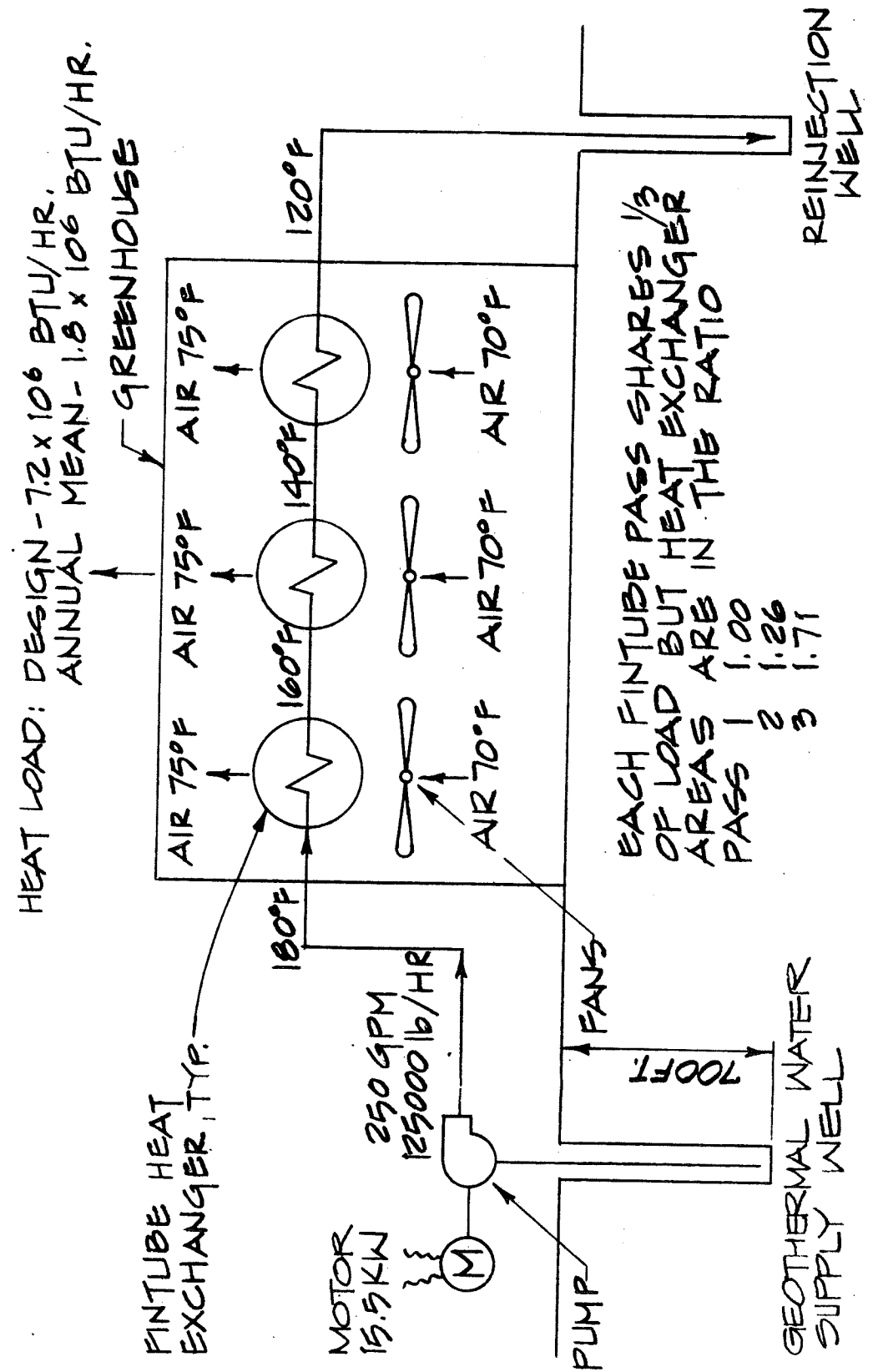

1 ACRE QUONSET HUT GREENHOUSE
DESIGN BASIS - 10°F OUTSIDE W/75°F INSIDE

FIG. V-4

Use of Geothermal Water in the Greenhouse

While the parts per million of solids in the geothermal water of the study area are quite low, generally less than 1100 ppm, the presence of some heavy metals in some samples, primarily boron, precludes the use of geothermal water in direct contact with the plants. The water quality varies greatly, and it may be possible to use it in direct contact at some locations; but for purposes of this analysis, the geothermal waters are used exclusively for heating the air in the greenhouses. (Soil warming is another potential use).

The water is pumped from supply wells, passed through closed finned tube heat exchange coils, and discharged to reinjection wells. Figure V-4 illustrates such a heating system for a one-acre quonset hut configuration.

To reduce the number of wells required, three heat exchangers are used in series. As the supply wells are drilled deeper, the water becomes hotter and the size and cost of heat exchangers becomes smaller. An effort was made to determine the economic optimum for well and heat exchanger costs. Values for well depth vs. temperature were approximated from Figure V-3 using average values. But as illustrated in Figure V-5, the lowest cost was only moderately dependent on well depth so long as it was in the range 400 to 800 feet deep.

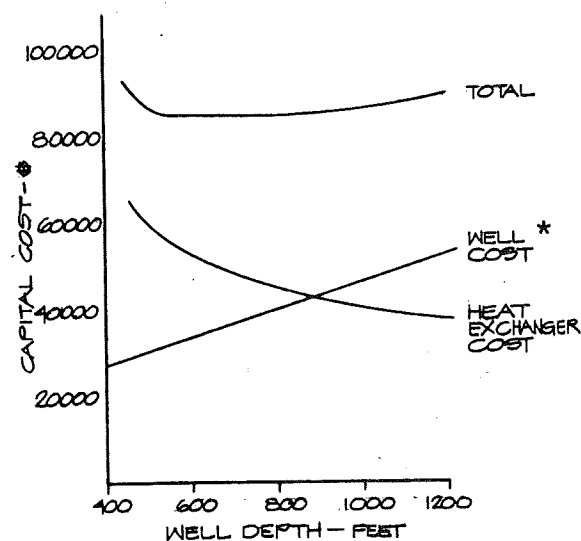

GEOTHERMALLY HEATED GREENHOUSES - OPTIMUM WELL DEPTH BASIS - 1 ACRE GREENHOUSE
 BASIS: DEPTH TEMPERATURE RELATIONSHIP AS SHOWN IN FIGURE V-3 WATER DISCHARGE TEMPERATURE, 120°F. COST OF FINNED TUBE HEAT EXCHANGERS IS \$5/SQ. FT. FIG. V-5

The greenhouse business clearly benefits from size or scale of operations. A study conducted by Barmettler and others in 1969 showed that the per square foot investment requirement for three different size units varied substantially. The three different sizes investigated were: 10,000 square feet, 43,560 square feet and 871,000 square feet.

* Per telephone conversation with local well driller (see page 28)

GREENHOUSE INVESTMENT COSTS

Growing Unit-Size	Investment Costs
10,000 square feet (0.230 acres)	\$3.32/square foot
43,560 square feet (1.000 acres)	\$2.32/square foot
871,200 square feet (20.000 acres)	\$1.36/square foot

The differences in per square foot investment for the larger 20-acre unit was 1:2.44 for the 20-acre unit over the 10,000 square foot house, and 1:1.43 for the one-acre range over the 10,000 square foot house.

These same economics are relevant today for greenhouse operations. The 20-acre unit, although substantially more economical (1:1.71), is not so different for the five acre unit. See Figure V-6.

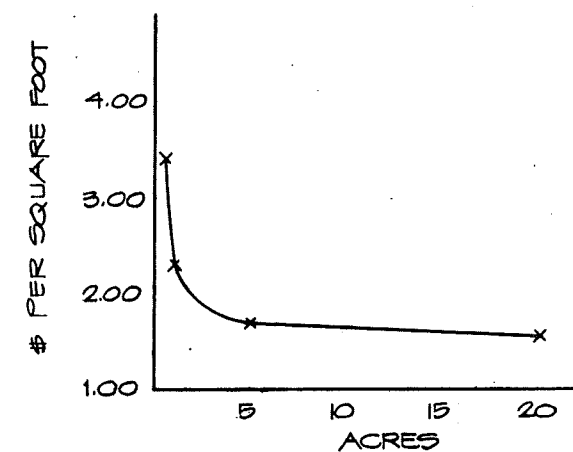

INVESTMENT ESTIMATIONS FOR FOUR DIFFERENT GREENHOUSES (1969-1970)
 SOURCE: E. BARMETTLER

FIG. V-6

At 1975-76 prices, and assuming comparable costs relationships between different greenhouse sizes, the following prevails (rough estimate).

Growing Unit, Size	Investment Cost
10,000 square feet	\$6.98
43,560 square feet	\$4.88
871,200 square feet	\$2.86

From the figures and the chart (Fig. V-6) it is estimated that a five-acre unit is somewhere between \$4.88 and \$2.86-- a spread of nearly two dollars. Estimates are that a cost of around \$3.25 to \$3.75 appears practical under 1975 prices. From the above estimates, based on 1969 data, it appears that scale economics are substantial and that to be competitive a minimum five-acre greenhouse requiring a capital investment of about \$210,000 is required.

Greenhouses are particularly desirable businesses for reducing unemployment in Lassen and Modoc Counties. Labor is the single largest production cost in operation of a greenhouse. Labor intensity is fairly high, three to five laborers per acre, and should reach its peak during the winter season when competition from field crops is lowest. While opinions vary on the minimum economical size for a greenhouse operation, a generally accepted figure is about five to ten acres. Each 10-acre installation would require a minimum of 30 to 50 personnel. Ten to twelve such greenhouses in Lassen County and five in Modoc County would reduce their unemployment levels from among the highest in the nation to among the lowest. Practical considerations must account for whether the relatively small available work forces in these counties could supply the specialized kinds of labor required. Nevertheless, the potential of greenhouses to produce new job employment opportunities is apparent.

Greenhouses are normally run at 75°F to 85°F during the day. (Air temperatures are sometimes allowed to drop as low as 65°F at night.) Since the energy consumption is directly proportional to the difference between the ambient outdoor and the greenhouse temperatures, it is a direct function of climate. Energy consumption is high in greenhouse operations, so that using conventional fuels it would not be as practical to operate a greenhouse in Lassen and Modoc Counties during late fall, winter and early spring months. Use of geothermal energy, however, enables 12-month operation at operating costs substantially less than equivalent greenhouses in far warmer climates.

As an example, the heating costs of one-acre greenhouses located in Susanville or Cedarville using geothermal water were compared to greenhouses in Modesto, Fresno and Los Angeles using fuel oil and natural gas. Listed below are the heating degree days of each area, the annualized cost of equipment and fuel for the three different heating modes. Except for gas heating in Los Angeles, geothermal heating is the most economical system, with gas a close second and heating oil a distant third. It must be recognized, however, that availability of gas is rapidly diminishing, that gas costs are quickly increasing, and that geothermal energy will soon be less costly, even than gas heating in Los Angeles.

COST OF HEATING A 1-ACRE GREENHOUSE

Location	Heating Degree Days	Annual Cost of Heating Equipment \$ Capital at 9 percent 10 years plus fuel		
		Oil (3)	Gas (2)	Geothermal
Susanville	6248	----		*7,600
Cedarville	6255			*7,600
Modesto	2767	21,900	9,300	
Fresno	2650	21,300	8,900	
Los Angeles	1819	15,600	6,230	

* Includes power cost for pumping

(2) Gas at \$1.50 per million BTU

(3) Oil at 38.5 cents per gallon

If all other factors are assumed equal, i.e., capital, labor, supplies, etc., a greenhouse located in Lassen or Modoc County should have a competitive advantage over an equivalent one in a warmer climate when the savings in energy costs exceed the added costs for shipping supplies and produce to market. Since the geothermally significant areas are generally remote from major markets, this balance can prove critical. These values are compared below for greenhouses at various locations shipping tomatoes to a market in San Francisco. It will be seen that despite the much greater shipping distance, the geothermally heated greenhouse has a very large advantage over oil heated greenhouses in Modesto and Fresno and is on a par in cost with gas heated greenhouses. By giving added value for the uninterrupted nature of the geothermal source of energy, it places it in a more advantageous position even than gas.

To appreciate the economic advantage of geothermal heating over oil, consider a grower in Modesto or Fresno who normally earns a profit of 10 cents per pound where greenhouse tomatoes wholesale for 50 cents per pound. The Cedarville supplier in this case would earn an additional 5 cents; an increase in profit equal to 50 percent.

A unique quality of greenhouses is that they can grow a large variety of crops, all of which require nearly the same operating temperature. The cost of heating as a consequence is nearly independent of the crop raised. Once the dollar savings in energy through use of geothermal water is known, the unit economic advantage (the energy savings in cents per pound of product) of a great variety of greenhouse products can be readily determined. This multi-product capability of the capital investment is important to financing the business. The ability to change products to follow market trends offers a unique protection and assurance of servicing of the financing.

TRADE-OFF OF SHIPPING COSTS VS. ENERGY COSTS FOR GREENHOUSE TOMATOES

	Cedarville	Fresno	Modesto
Miles to San Francisco	321	186	93
Shipping Cost ¢/lb.	1.3	(1) 0.6	(1) 0.4
Fuel Cost ¢/lb. (2)			
Geothermal	3.2	-----	-----
Oil	-----	9.5	9.5
Gas	-----	3.7	3.8
Total Cost ¢/lb.			
Geothermal	4.5		
Oil		9.5	9.5
Gas		4.3	4.2

(1) Estimated

(2) Includes capital cost of the heating system and fuel cost

(3) Basis 120 ton/acre

Marketing of greenhouse products requires good judgment in the cycling of crops and timing for delivery to the marketplace. Greenhouse products bring the largest price during off seasons of field crops. In some cases, market prices fluctuate very widely, yielding a large net loss for operations at the lower end of a fluctuation and a substantial profit at the upper end. Table V-3 lists several products which can be grown in greenhouses, their yields, costs of growing and market price ranges. On the right hand side of the Table, the savings in cost of energy achieved by growing the crop in a geothermally heated greenhouse in Cedarville, in Modoc County, over an oil heated one in Modesto is shown. The savings range from 7 to 20 percent of the wholesale prices.

Conclusions:

Application of low temperature geothermal energy to greenhouses in Modoc and Lassen Counties appears to be a most desirable application. Greenhouses there would have a major impact on unemployment, would have negligible deleterious environmental effects, and could compete at an advantage with greenhouses in more temperate counties.

TABLE V-3

Crop	Units Produced	Quantity Per Acre	Growth Cycle Days	Cost of Growing \$/Acre (Including Energy-Oil)	Wholesale Market Price Range Cents/Unit	Energy Costs		
						Fuel Oil (1) Cost (3) Cents/Unit (Modesto)	Geothermal Energy Cost (4) Cents/Unit (Cedarville)	Savings Cents/Unit
Tomatoes (4)	lbs.	240,000	360 days/2 crops	122,200	40-60	9.5	4.50	4.5
Cucumber	lbs.	78,000	50	19,700	25-35	3.85	1.35	2.50
Leaf Lettuce	lbs.	65,000	50	19,700	20-35	4.62	1.62	3.00
Red Radishes	Bunches	55,000	28	11,032	15-45	3.05	1.07	1.98
Green Onions	Bunches	98,500	50	19,700	15-45	3.05	1.07	1.98
*Celery	lbs.	157,600	120	47,280	20-40	4.57	1.62	2.97
*Squash (2)	lbs.	65,000	50	19,700	20-40	4.62	1.62	3.00
*Zucchini	lbs.	65,000	50	19,700	20-40	4.62	1.62	3.00
*Cantalope	lbs.	60,000	90	35,460	40-100	9.00	3.15	5.85
Bedding Plants	Pony Packs	60,000	60	23,640	25-50	6.00	2.10	3.90
Philodendrons	Pots	30,000	75	29,550	75-125	15.00	5.25	9.75
Ferns	Pots	30,000	75	99,550	75-125	15.00	5.25	9.75
Carnations	Blossoms	197,000	75	29,550	10-20	2.28	0.80	1.48
Chrysanthemums	Blossoms	85,000	75	29,550	30-40	5.29	1.85	3.44
Cyclamen or Azalia	Pots	30,000	75	29,500	75-125	15.00	5.25	9.75

*Limited experience on greenhouse yields.

(1) Basis: Modesto, California 2767 Heating Days

(2) Straight yellow or butterfly squash

(3) At \$60/day average over one year.

(4) At \$21/day average over one year.

2. Kiln Drying Lumber

Lumbering has been and continues to be the only major manufacturing activity in Lassen and Modoc Counties. Although it remains quite important in the area, improved technology coupled with increased competition by firms outside the area have reduced the number of mills and the number of associated jobs in this industry. Developing an economic edge through lower cost forms of energy becomes critical priority in this industry. Presently four sawmills operate in Lassen County: Coin Lumber and Sierra Pacific Industries in Susanville, Little Valley Lumber Co. and Main Lumber Co. in Bieber. Total annual production in 1974 was 125,646,230 board feet. There are three sawmills in Modoc County whose capacity in 1968 was 2,000,000 board feet.

In small saw mills where drying kilns are heated by steam from conventional oil-fired boilers, substitution of geothermal energy for the heating energy source can achieve substantial energy cost savings. In larger, well integrated mills, all energy from operations can be provided by burning sawdust and other wood waste products. If a market develops for the waste products or where the energy can be more economically applied elsewhere, the geothermal source may also become economical in integrated plants. It is evident that such a by-product market is developing. Bohemia, Inc., (Eugene, Oregon) has built a \$4.25-million plant capable of treating 400,000 tons/year of bark to provide plywood extender and vegetable wax. Secondary uses for sawdust, however, are still a problem. Drying lumber in batch kilns is standard practice for most upper grade lumber in the western United States. The two basic purposes of drying are to set the sap and to prevent warping.

The sap sets at 135° to 140° F. Warping is prevented by establishing uniform moisture content throughout the thickness. Lumber left to dry under ambient conditions loses its moisture from exposed surfaces at a faster rate than internally. This differential drying rate sets up stresses which cause the warping. Moisture occurs in wood in cell cavities and in the cell walls. The majority of the moisture is first lost from the cavities. This loss is not accompanied by changes in the size of the cell or in warpage. When water is lost from the cell walls, however, shrinkage of the wall fibers take place setting up the stresses which cause warping.

In the kiln drying process, the evaporation rate must be carefully controlled to prevent these stresses. The allowable drying rates vary from species to species and decrease with thicker cut sizes. Kiln drying is usually carried out as a batch process. The kiln is a box shaped room with loading doors at one end. It has insulated walls and ceiling and has fans to recirculate the air at high velocity through the lumber. The sawed lumber is spaced and stacked to assist the free air movement and is loaded by large fork lifts or other specialized lumber handling trucks into the kiln. When fully loaded, the doors are closed and the heating cycle is started. Make up air, preheated to a temperature consistent with the drying schedule, enters the kiln where it recirculates through the stacked lumber and picks up moisture. Exhaust fans draw the moist air from the kiln and discharge it to the atmosphere. The exhaust is primarily air and water. The rates of flow and temperature are adjusted so that the temperature and the humidity in the kiln will retard the drying rate sufficiently to prevent warping. During the drying cycle, the lumber loses a large portion of its weight from evaporation of water, 50 to 60 percent for many species.

Drying schedules are specific for each species of lumber and for size. The larger the size and the more tightly the moisture is held in the wood fibers, the slower the schedule. Drying schedules range from less than 24 hours to several weeks per batch. Table V-4 shows typical drying schedules for ponderosa pine. It will be noted that drying proceeds slowly as evidenced by the gradual decline in the EMC, equilibrium moisture content of the wood.

In heavier lumber cuts it is sometimes necessary to remoisturize the surface at the end of the schedule (see select 12/4 ponderosa pine in Table V-4). Re-moisturizing is achieved by raising the wet bulb temperature, and is done to reduce the stress differences caused by low surface moisture compared to higher moisture in the heart of the lumber.

TABLE V-4

TYPICAL KILN DRYING SCHEDULES

Ponderosa pine	Dry Bulb(°F)	Wet Bulb(°F)	Time	E.M.C.(%)
4/4 All Heart Common Sort (fast on well sorted stock)	160° No conditioning	130°	Approx. 21 hrs.	5.8
4/4 All Heart RW (Conservative) Common	150°	130°	up to setting	8.0
	150°	125°	to 12 hrs.	6.9
	160° No conditioning	130°	12 hrs.till dry (24-28 hrs.)	5.8
4/4 Half and Half Common (Mostly 8")	160° No conditioning	140°	40-50 hrs.	8.0
Shop and Select 12/4	115°	108°	First day	14.1
	120°	110°	Second Day	12.1
	125°	115°	Third Day	12.1
	130°	120°	Fourth Day	12.1
	140°	130°	5th-10th	11.9
	145°	130°	10th-12th	9.5
	150°	135°	12th-16th	9.5
	155°	140°	15th-18th	9.4
	160°	140°	18th-22nd	7.9
	Cool 180°	170°	Approx.24 hrs. Equalizing & Conditioning	11.1

E.M.C. = Equilibrium Moisture Content

From Kiln-drying Western Softwoods, Moore Dry Kiln Company, Oregon.

Green wood contains high quantities of moisture. Ponderosa pine, for example, runs approximately 60 percent moisture. Because of the physical and chemical binding to the wood chemicals it takes from one and one half to three times the energy to evaporate moisture from wood as it does from pure water. Energy consumed in kiln drying wood varies considerably for different species. Drying energy therefore, varies widely with the species and sizes processed.

ENERGY CONSUMED IN KILN DRYING WOOD

Lumber	Energy Use BTU/lb H ₂ O	BTU/Dry Board Feet
Douglas Fir	2000-3000	1560-2340
Southern Yellow Pine	1600-2200	4600-6300
Red Oak	3000+	7850+

Other kiln schedules call for high temperature drying at temperatures to 240°F (White fir or hemlock studding), but these are the exceptions and not the rule.

The species which predominate in the study area include White fir, Ponderosa pine, Jeffrey pine, Lodgepole pine, Incense-cedar and Quaking aspen.

Geothermal energy would be adapted to kiln drying by passing air over finned heat exchanger tubes carrying the hot water. The finned tube heat exchanger could be placed inside existing kilns so that the air recirculation route would include a pass over the heat exchangers. For economic design, the water temperature must be at least 20 to 40°F above the ambient operating temperature in the kiln. This would mean digging the supply wells deeper than for most other low temperature applications of geothermal energy to obtain temperatures in the range 200 to 240°F. Where geothermal water of insufficient temperature is available (less than 180° F for most uses), energy supplies could be supplemented by conventional heating systems during the final high temperature portions of the drying schedules.

Geothermal heating in kilns is thermodynamically very inefficient. The only part of the water heat available for drying in the kiln is its sensible heat between its entry temperature and a temperature 10 to 20°F above the ambient kiln temperature. Thus if 200°F water was used to heat a kiln whose schedule called for 140°F at the start of the drying schedule and 180° F at the end, only 10 to 15 percent of the heat in the water would be available for drying. Minimum geothermal water temperatures for several sizes and species of lumber are shown below.

MINIMUM GEOTHERMAL WATER TEMPERATURES FOR KILN DRYING

Species	Minimum Geothermal Water Temperature ° F @ kiln inlet		
	Lumber Size	4/4	8/4
Ponderosa Pine		175	195
Sugar Pine		175	175
Englemen Spruce		175	--
Sitka Spruce		195	195
Douglas Fir		195	195
Incense Cedar		185	--

The discharged water for these applications would have temperatures ranging from 160 to 180° F and would be available for other applications in the mill, for heating of office buildings, or for outside multi-use low temperature applications such as cattle feed lots and fish farming.

Adaptation of geothermal energy to kiln drying would not directly affect employment because the drying facilities already exist, and it is unlikely that its economic advantages would justify the construction of entire new saw mills. The lumber industry in Modoc and Lassen Counties, however, has been decreasing over the last several decades. The increased efficiency contribution by geothermal energy should help saw mills in these counties compete with outside mills and slow or reverse the employment trend.

To illustrate the comparative advantages of geothermal energy for kiln drying, a theoretical analysis was prepared based on use of 200° F water from a well with a capacity of 260 gpm for drying in a kiln with a capacity of 100,000 board feet per batch. The kiln dries 4/4 Ponderosa pine Sap common to a final dry bulb temperature of 150° over a 66-hour drying schedule.

The drying schedule is as follows:

Dry Bulb Temperature °F	Wet Bulb Temperature °F	Time Hours
140	115	0-24
150	120	24-66

(1.42 pounds of water evaporated per board foot)

The analysis compared the annual operating cost of a geothermal system to a conventional one, using an oil fired boiler. The flow diagrams are outlined in Figure V-7 showing the basic quantities of air and fuel flow based on heat

I. CONVENTIONAL BOILER SYSTEM

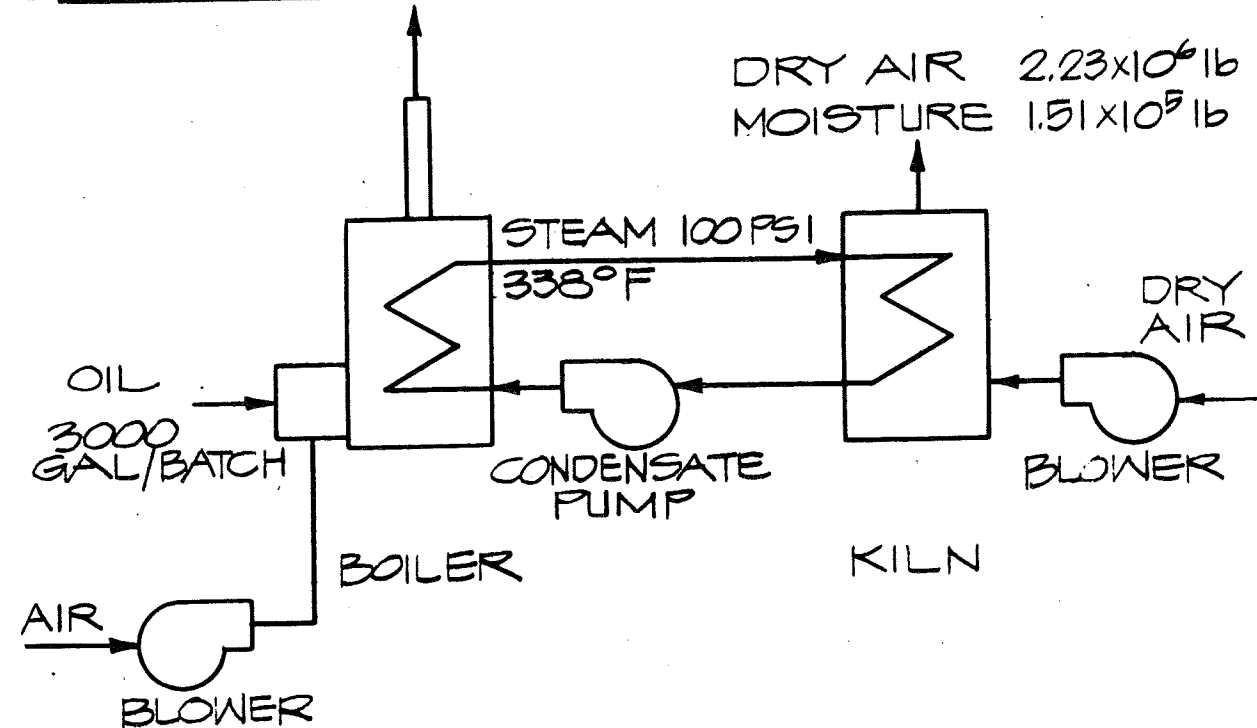

II. GEOTHERMALLY HEATED SYSTEM

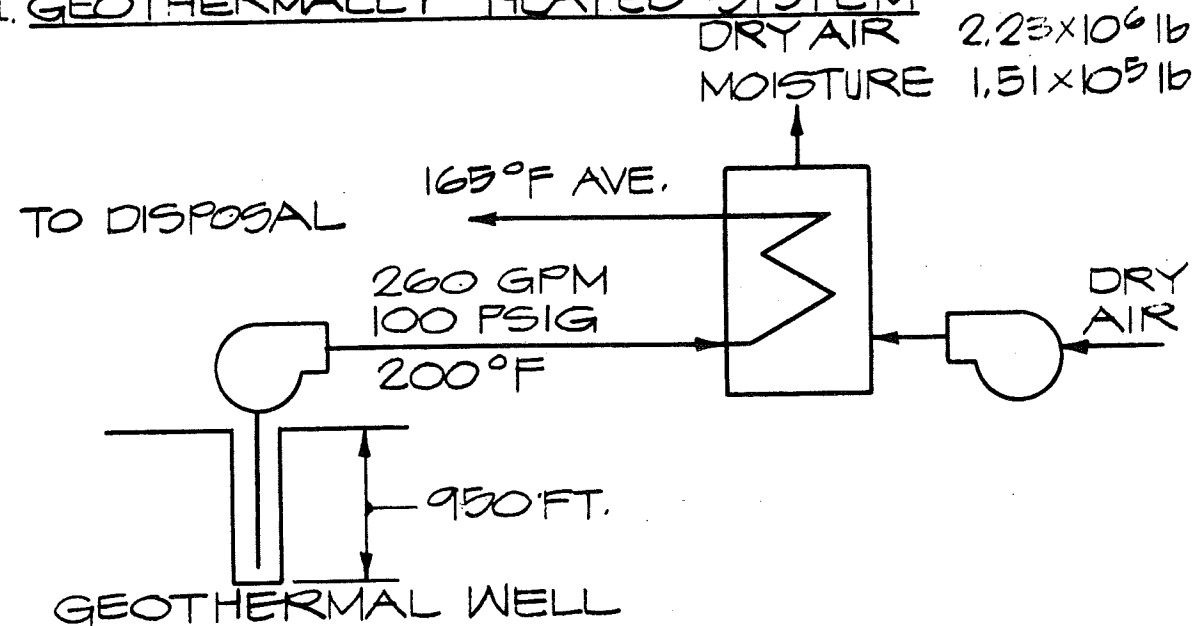

KILN DRYING LUMBER
100,000 B.F. 66 HR. SCHEDULE
(PONDEROSA - 1/4 SAP COMMON)

FIG. V-7

and material balances. Despite its low thermal efficiency, the geothermal system had a low annual operating cost of \$15,000. This figure was based on modification of an existing kiln and included pump operating costs and capital depreciation costs of the geothermal supply and disposal system and process heating equipment based on nine percent interest rates and a ten-year life. The conventional boiler system was assumed to be in existence, so that only fuel costs were charged against it. These amounted to \$126,000 per year, a savings of \$111,000 per year (1.06 cents per board foot).

The outlook for the lumber industry in Modoc and Lassen Counties is encouraging in a limited sense. It is probable that the worst of the decline is over. As the industry recovers and gains enough working capital for modernization, more by-product use of lumber waste products will develop and the application of geothermal energy for kiln drying will become more attractive. Conversion of wood wastes, particularly sawdust, from use as a fuel to use as a by-product can lead to new employment opportunities. A significant portion of these opportunities would occur in the important blue collar sector of the labor force.

3. Food Processing--Onion Dehydration

Low temperature drying in the food processing industry is especially adaptable to geothermal energy as the heat source. This is because drying requires large quantities of low intensity heat. The geothermal energy source is one of the least expensive, and its temperature is less likely to get out of control and overheat the product. Onion drying fits into this category particularly well because the onions are dried to only 0.18 of their original weight. For each pound of product, 5.4 pounds of water must be evaporated and in excess of 10,000 BTU of heat provided.

Onions are grown in the Tule Lake area along with potatoes. Surprise Valley also grew onions but, though the quality of the crop was good, poor market conditions discouraged further development there before the crop could become established. Onion drying is an intensive process. One dryer installation of the type described below would process the output of 800 to 1000 acres. Bringing such large agricultural areas into production, coupled with the storage, transportation and processing of the onions, would affect the employment of several hundred people.

Onions grown for processing are of very specific varieties suited for dehydration. The dehydration industry has developed the Creole Onion, the Southport Globe Onion, and the hybrid Southport Globe. These onions are white in color and are more pungent and substantially higher in solids than the commercial household product purchased in local grocery establishments. The crop is harvested mechanically, and transported to the dehydrator in bulk.

The normal handling procedures for onions are as follows: the bulk onions are taken to the dehydrators and are loaded into large bins for curing; dry air is passed through the onions to take off the excess surface moisture. This treatment prepares the onion for further processing. The curing treatment may continue up to 72 hours.

From the curing bins, the onions are moved by conveyors or other mechanical means to the processing line. Here the product is inspected (inspections start in the field), and any tops are removed; the onion is washed under a high pressure washer, then soaked in stainless steel tanks, washed again under pressure and resoaked in a chlorine bath to reduce bacteria levels. The onions are then placed into stainless steel storage tanks. The onions are fed into a slicer from the storage tanks, and are then moved along the line to the dryer.

The dryer used is a machine developed by Proctor and Schwartz for a California vegetable processing firm. The dehydrator is a 200-foot four-stage system. The system is highly automated, capable of handling 10,000 pounds of raw product per hour, or 240,000 pounds per 24-hour period. From the slicer, a continuous flow carries the onion slices to the dryer, at which point the wiper spreads the onion slices evenly over the open feed end extension of the dryer. At this point the product is transferred to the continuous dryer conveyor for the first stage of the four-stage dryer.

The Onion Drying Process

Stage I:

The Proctor and Schwartz onion dehydrator is composed of a four-stage perforated belt conveyor system. The first stage is where the bulk of the moisture in the product is removed. It is a critically important stage, since product quality is determined by control over the moisture removing process. Temperature and air volume are closely measured; in this first stage the air temperature is maintained at 210°F. The Proctor and Schwartz model is capable of exhausting 31,500 cubic feet of moisture laden air per minute in this first stage of operations.

Stage II:

At this point, where the bulk of the readily removable moisture has been exhausted, the onions are transferred to the second processing stage (dehydrator). At the point of separation, devices are used to load the second stage to greater depth of onions on the conveyor. The partially dried onion slices are separated so that air can move freely through the product in this second stage of dehydration. The temperature is lowered to 180°F, and the air volume is also reduced by about 35 percent. As the product moves through this operation, the onions are turned and mixed so that the deeply diffused water is slowly withdrawn from the onion slices.

Stage III:

Stage three continues to extract the more deeply diffused water. The product moves from the second stage to the third stage, and again the temperature is lowered as is the air volume. The more deeply loaded conveyor moves through a drying temperature of about 150°F, and the volume of air flow is lowered another 25 percent. In this third stage, very deeply diffused and difficult to extract water is further removed. Since very little moisture remains in the product, quality maintenance needs to be guarded very closely; up to this point, moisture evaporations moderated the effect of heat on the product slices.

Stage IV:

The final stage receives the onions; they are waded to a six foot depth. Dehumidified air is moved through the six-foot layer to bring the product to its final milling quality. In Stage IV, temperatures are reduced to about 135° F, but the air volume is again increased by 25 percent.

FOUR STAGE ONION DEHYDRATION
10,000 lbs/hr. CAPACITY-RAW PRODUCT (Single Line)

Processing Stage	Air Volume Cubic Ft./min.	Air Temperatures
I	31,500	210° F
II	20,000	180° F
III	15,000	150° F
IV	20,000	135° F
<hr/>		
Single Line Totals:	86,500 cubic Ft./min.	290,000 - 420,000 BTU/min.

Probable Investment Required
(Gallon heated system)

Land Resources (8 acres)	156,000
Proctor & Schwartz Dryer (Twin-Line)	\$2,850,000
Building 300' x 50' x \$15 & Service Equip.	350,000
	<hr/>
	\$3,356,000

The air is induced and pushed by fans with over 40 million BTUs per hour heat source capacity; it is estimated that to produce about 70,000 pounds of dehydrated onions per day, it will require between 35,000,000 to 50,000,000 BTU per hour, depending on a wide variety of both internal and external environmental and product variables (350 to 500 therms per hour).

Assuming a 24-hour run and a five-month operation, the energy demand would be very substantial. (Where storage capacity is sufficient the operating season could be extended).

42,500,000 BTU/hr X 24 hr/day =
10,200 therms/day x 150 days/season = 1,530,000 therms.
Priced at 29¢ per therm = \$443,700 for fuel oil

The operations plan assumes a fuel cost of \$440,000 to \$450,000 for a twin line dryer plant. The plant is calculated to cost (Capital Investment) roughly 3.25 to 4.00 million dollars. The recent changes in metal prices and labor costs have driven the cost of engineering substantially higher than just three years earlier when the same investment could have been achieved for roughly 2.2 million dollars.

It is estimated, again from the above, that a well engineered arrangement as visualized above could produce about 70,000 pounds of dried onions per day or about 10,500,000 pounds during the five-month drying season. To produce 10,500,000 pounds of dry product, it will require roughly 35,000,000 pounds of fresh product per line, or 70,000,000 pounds. Assuming about 40,000 pounds of usable onions per acre, it would require the production of 800 to 1,000 acres of good onion producing land.

Per Season Estimates

<u>Inputs</u>	<u>Output</u>	<u>Acres</u>
70,000,000 lbs.	10,500,000 lbs.	875
<hr/>		
<u>Per Day Estimates</u>		
460,000 lbs.	69,000 lbs.	11.50
<hr/>		
<u>Per Hour Estimates</u>		
19,200 lbs.	2,875 lbs.	0.48

ENERGY DEMAND - TWINLINE ONION DEHYDRATORS
CAPACITY 230,000 lb. Raw Product Per 24 Hr. Day

BTU Required (Period)	BTU	Bbls. of oil	Dollars
Per Hr.	42,500,000	7.228	121
Per 24 Hrs.	1,020,000,000	173.469	2,914
Per 150 Day Season	153,000,000,000	26,020.407	437,143
Per Ton of Product	29,142,860	4.9600	86.2650
Per Pound of Product	14,575	0.0025	0.0416

One Bbl refined heating oil = 58.8 Therms (42 U.S. Gallons).

One U.S. Gallon = 140,000 BTU = 1.4 Therm.

Per hr. production of finished onion product 1,438 pounds or 0.72 tons per line.

1.4 Therm = 40¢ = 1 U.S. Gallon No. 2 fuel oil

1.0 Therm = 28.57¢ = .714 U.S. Gallons No. 2 fuel oil

The fuel cost for producing 1 lb. of finished product is calculated to be 4.164¢.

An application of geothermal energy to such a process is outlined in the flow diagram shown in Figure V-8. Use of geothermal energy would not affect the quality of the product since it would not change the control temperatures. The onions are fed in on the left side and flow through the successive stages to the right. Air flows countercurrent to the onion flow, increasing its temperature between stages by passing over geothermally heated coils in the heat exchanger.

To meet the total requirements, deep wells are required because of the need for 240°F water. If such high temperature water is not available, then the geothermal energy source would heat only the latter three stages, and a conventional heater could be used to heat the first (this heat could be provided by boosting the temperature of the already hot geothermal water with hydrocarbon fuels). The first stage requires intensive high temperature heat; the quantity of heat required is much greater than the other stages, so that it would greatly reduce the fuel savings.

It is estimated that the cost of the geothermal supply and reinjection wells, the auxiliary equipment and the four stages of heat exchange in the drying process would cost \$202,000 annually (based on nine percent interest and 10-year depreciation). Since the energy cost based on use of fuel oil was \$437,000 for a 150-day season, this represents potential annual savings of \$235,000, equal to 2.24 cents per pound of dry product compared to the wholesale price of sliced dehydrated onions (1/77) of approximately \$.98 to \$1.25/pound. A check with the manufacturer of the drying equipment, Proctor & Schwartz, indicated that a savings of this magnitude would be of interest.

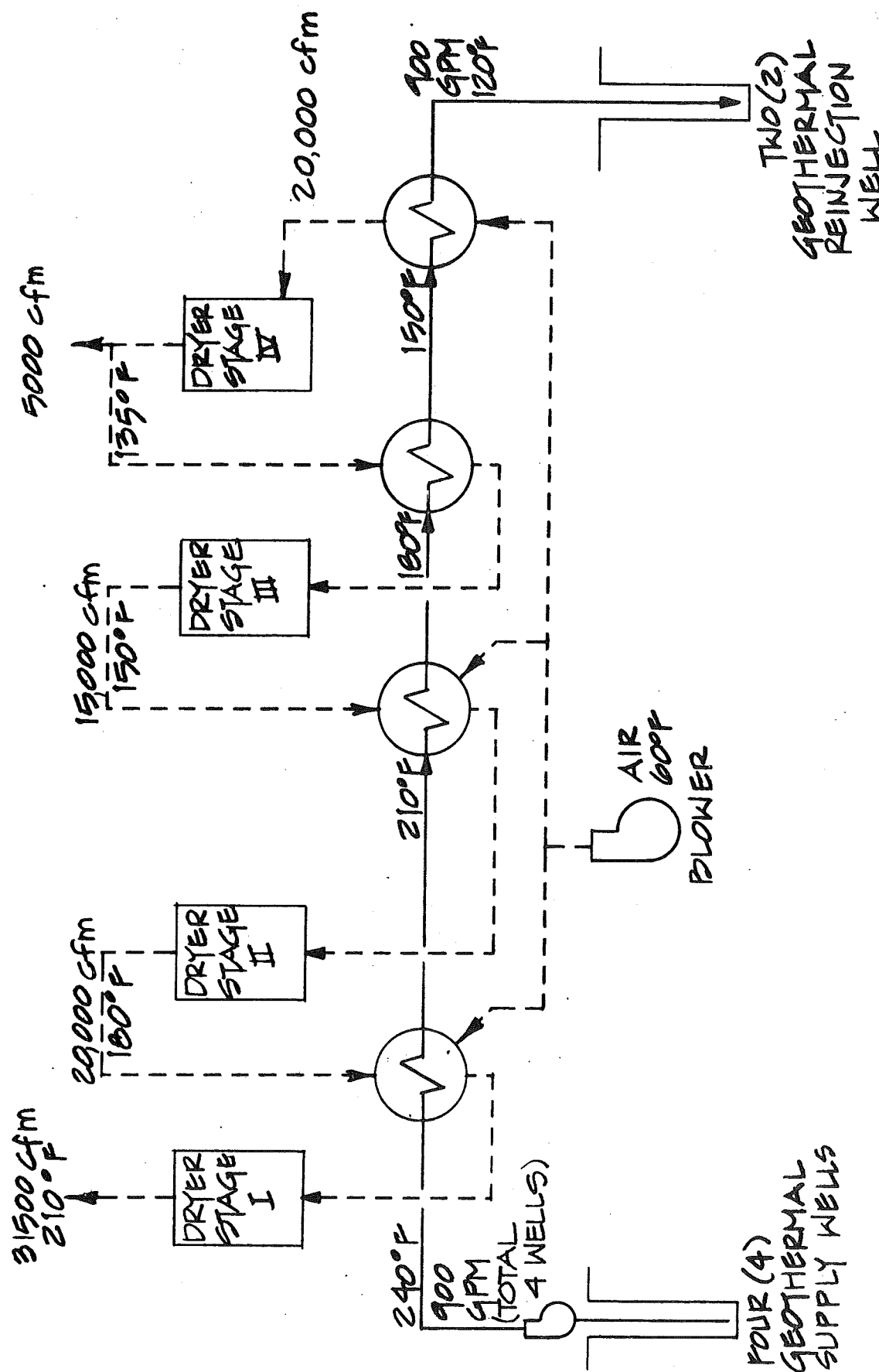

ONION DEHYDRATION PLANT
PROCESS FLOW SHEET

FIG. V-8

4. Feedlot Heating

Winter feeding cattle in geothermally heated areas offers the following advantages:

- It would enable the marketing of more valuable beef, finished yearling steers (1050 lbs) at 7 to 10 cents more per pound, than backgrounding calves (670 lbs).
- The conversion of food weight to animal weight would be greater.
- It would reduce mortality.

This study analyzed the advantages and disadvantages for two feedlots, one in which a small feedlot is operated by an individual rancher, and a second designed to handle cattle from large surrounding areas.

Healthy ruminant animals such as beef cattle are walking heat sources, because the fermentation of food products generates large quantities of heat. Nevertheless, extreme cold can have a negative impact on the animals' health and weight gain. This factor, coupled with a shortage of feeds, causes ranchers in the vicinity of Susanville to ship animals south during the winter months. In the Surprise Valley area where feed is more plentiful, some herds are held over the winter months despite the cold weather.

Low temperature appears to have two important effects on the animals' weight gain. First, a temperature exists below which an animal must elevate its heat production in order to maintain body temperature. This temperature varies with animal size, coat condition and acclimatization. The elevation in heat production of necessity means that food is diverted from productive processes to that of heat generation to replace that lost to the environment. Young¹³ defined the environmental temperature as the "critical temperature." He calculated the stress on an animal by multiplying the temperature below critical by the number of days over which the temperature occurred, i.e., degree-days, and showed the quantity of energy and feed required for the animal to maintain weight as shown in Table V-5.

TABLE V-5

ESTIMATED EXTRA RATION ENERGY REQUIRED TO COMPENSATE FOR EACH UNIT OF COLD STRESS. COLD STRESS IS MEASURED IN UNITS OF DEGREE-F DAYS OR DEGREE-C DAYS AND REPRESENTS THE NUMBER OF DEGREES THE DAILY EQUIVALENT STILL AIR TEMPERATURE OF THE ENVIRONMENT IS BELOW THE CRITICAL TEMPERATURE OF THE ANIMAL

Thermal insulation of the animal Mcal.m ⁻² .24h ⁻¹	Extra ration required to compensate for cold stress (energy/degree day)					
	For one degree-F day.			For one degree-C day.		
	Metab. energy Mcal.	Grass* hay lb.	Barley* grain lb.	Metab. energy Mcal.	Grass* hay lb.	Barley* grain lb.
5	0.111	0.148	0.092	0.200	0.266	0.166
10	0.056	0.074	0.046	0.100	0.133	0.083
15	0.037	0.049	0.031	0.067	0.089	0.056
20	0.028	0.037	0.023	0.050	0.067	0.042
25	0.022	0.029	0.018	0.040	0.053	0.033
30	0.018	0.024	0.015	0.033	0.044	0.027
35	0.016	0.022	0.013	0.029	0.039	0.024
40	0.014	0.018	0.012	0.025	0.033	0.021
45	0.012	0.016	0.010	0.022	0.029	0.018
50	0.011	0.015	0.009	0.020	0.027	0.017

*Grass hay with 0.75 Mcal. metabolizable energy/lb. and barley grain with 1.21 Mcal. metabolizable energy/lb.

A second effect of low temperature is to reduce the ability of the animal to efficiently digest its feed. Young and Christopherson¹⁴ measured the prolonged cold effects on digestion and metabolism in ruminants and showed decreased digestibilities relative to 18° C (value = 100) as shown in Table V-6.

TABLE V-6: Estimated apparent digestibilities of ration dry matter (DM), daily metabolizable energy (ME) for maintenance and gain, and total feed requirements of a dry pregnant beef cow and a feeder steer with access to shelter but no supplementary heating in Edmonton, Canada.

Month	Mean temp. (C)	DM dig. (%)	ME for maint. (Mcal)	ME for gain (Mcal)	Added ME for direct cold ^a (Mcal)	Total feed (kg)	Requirement relative to 18 C
DRY PREGNANT COW, 500 kg; ration in warm (18C) 55% DM dig. and 2.0 Mcal ME/kg.							
Jan	-15.0	47.1	15.7	—	0.6	9.52	140
Feb	-10.5	48.2	15.4	—	0.3	8.99	132
Mar	5.6	49.3	15.1	—	0.2	8.56	126
Apr	4.0	51.6	14.5	—	0	7.71	113
May	11.0	53.3	14.0	—	0	7.24	106
Jun	14.5	54.2	13.8	—	0	7.02	103
Jul	17.5	54.9	13.6	—	0	6.82	100
Aug	16.0	54.5	13.7	—	0	6.93	102
Sep	11.0	53.3	14.0	—	0	7.24	106
Oct	5.5	52.0	14.4	—	0	7.61	112
Nov	- 4.0	49.7	15.0	—	0.2	8.38	123
Dec	-10.8	48.1	15.4	—	0.4	9.06	133
Average	2.8	51.4	14.6	—	0.14	7.92	116
FEEDER STEER, 400 kg and daily gain 1 kg; ration in warm (18C) 70% DM dig. and 2.5 Mcal ME/kg.							
Jan	-15.0	62.1	12.3	12.6	0	11.20	121
Feb	-10.5	63.2	12.0	12.6	0	10.90	118
Mar	- 5.6	64.3	11.8	12.6	0	10.60	115
Apr	4.0	66.6	11.3	12.6	0	10.02	108
May	11.0	68.3	10.9	12.6	0	9.62	104
Jun	14.5	69.2	10.7	12.6	0	9.43	102
Jul	17.5	69.9	10.5	12.6	0	9.25	100
Aug	16.0	69.5	10.6	12.6	0	9.36	101
Sep	11.0	68.3	10.9	12.6	0	9.62	104
Oct	5.5	67.0	11.2	12.6	0	9.96	108
Nov	- 4.0	64.7	11.7	12.6	0	10.51	114
Dec	-10.8	63.1	12.1	12.6	0	10.96	119
Average	2.8	66.4	11.3	12.6	0	10.12	110

^a From Webster (1970).

Other climate-associated impacts on cattle are wind and mud. Wind reduces the animals' coat insulation and has the same effect as lower temperature. Mud and water also decrease the animals' ability to keep warm, and cause it to consume more energy for locomotion.

Fresh water requirements for feed lots are drinking water and equipment wash-down. One rancher in Surprise Valley noted that his cattle drank geothermal water. Of six samples tested in the area, two were essentially potable water quality and four were high in boron, so that the animals would have to be provided with potable water. Potable water needs of cattle are low; one moderate sized well would supply the large 18,000-animal feedlot analyzed below.

Cattle ranching is currently in the deepest recession in its history. A severely depressed market combined with rapidly escalating costs have created a situation even more serious for cattle ranching than the great depression of the 1930s. In 1975 the cost to keep a cow for one year was \$219, while the average return was \$140 per cow, a loss of \$79 per cow. Price predictions, as illustrated below, show a moderate increase over the years 1977 and 1978, but are not sufficient to provide material relief to the ranchers.

Projected Cattle Prices, Western U.S., 1976-78¹⁵

Class and Weight	CENTS PER POUND		
	1976 ^{a/}	1977	1978
Steer calves (300-500 lbs.)	35-40	38-45	44-53
Yearling steers (600-800 lbs.)	35-40	37-42	39-45
Utility cows (900 - 1,100 lbs.)	20-26	21-27	23-30
Choice steers (1,000 - 1,100 lbs.)	37-40	40-46	43-52

a/ Fourth quarter of 1975.

Introduction of geothermal energy as a component in the production of cattle will not materially change the basic economics of the system. Recovery of the market must await firming of an adequate price structure. What geothermal energy can contribute is operation of feedlots in the cold climates of Lassen and Modoc Counties which would not otherwise be practical. If these were operated by large individual ranches or as cooperatives, they would gain the advantages of high production sales and would add the profits of an additional major component in the marketing chain to the hard pressed ranchers.

The profit of a feedlot in these areas must compensate for the added cost of feed shipments, \$2 to \$3 per head, and the added cost of shipping heavier animals to market \$3 to \$4 per head (400 pound weight gain), for a total of \$5 to \$7 per head. A 400 pound weight gain represents \$160 to \$200 worth of added animal selling price. If we assume the feedlot makes a profit of 10 percent on the added weight, the \$16 to \$20 profit more than covers the shipping penalties.

The cost of adding geothermal warming to a feedlot is only a small part, about four percent, of annual operating costs, but it contributes importantly to feedlot efficiency. Lack of good quantitative data makes the science of estimating cold weather effects on weight gain inexact, but a best estimate (Dr. E. Barmettler) is that warming cattle in the study areas would save about \$41 per head as follows:

DOLLAR SAVINGS ACHIEVED THROUGH HEATING CATTLE

	Per Head
Savings in feed	\$ 14.
Savings in death loss	1
Added weight gain	32
	<u>\$ 47</u>
Cost of Geothermal warming system (capital and operating costs)	(6)
	<u>\$ 41</u>

This represents the savings per head in a cold climate feedlot with geothermal heating over one without heat.

It is estimated that in a large feedlot 1.5 hours of labor are required annually per head. An 18,000-animal feedlot would require a work force of about 10 to 15 personnel.

A winter feedlot in Lassen or Modoc Counties would require a level fenced area with windbreaks for protection from prevailing winds and an area warmed by underground pipes. In addition to providing heat for the cattle, the area would act to evaporate water and snow and reduce mud conditions.

Initially a small feedlot was considered sized for about 60 head of cattle and suitable for operation by individual small ranchers. The arrangement was based on a Department of Agriculture design¹⁶ with a concrete floor and overhead roof protection. The arrangement was modified to add wind protection and to provide water heating in the base concrete. But costs for such a system, \$40-\$50 per head, were prohibitive.

A second analysis based on a 55 acre feedlot with a capacity of 9000 head and an 18000-head per year production rate (2 rotations per year), substantially reduced costs. In this analysis, the overhead protection was deleted and 85 percent of the warming was done under soil and 15 percent under concrete. See Figures V-9, and V-10. The feedlot was designed for 650-pound feeder steers to be fattened to 1050 pounds over a 135-day feed period. The facility contains 30 compartments with a capacity of 300 head each.

A summary outline of the pertinent data is as follows:

TABLE V-7
COST SUMMARY
(18,000 head per year feed lot)

	(1) Per lb. Cost ¢/lb. gain @ 400 lbs.
<u>Operations</u>	
Feed Costs	16.95
Facility	1.26
Equipment	0.14
Labor	0.70
*General Overhead - 2% -	0.38
	<u>19.43</u>
<u>Livestock Costs</u>	
18,000 head, 650 lbs. @ 35¢	21.67
Interest 12% (6 mo.)	1.30
Death Loss 1%	0.22
	<u>23.19</u>
TOTAL CASH INVESTED (excluding geothermal costs) (Break-even cost)	42.62
Wells, pumps, Service Lines, etc. 12% interest	0.48 0.05
TOTAL COST	<u>43.15</u>

(1) Basis 1050 lb. market weight.

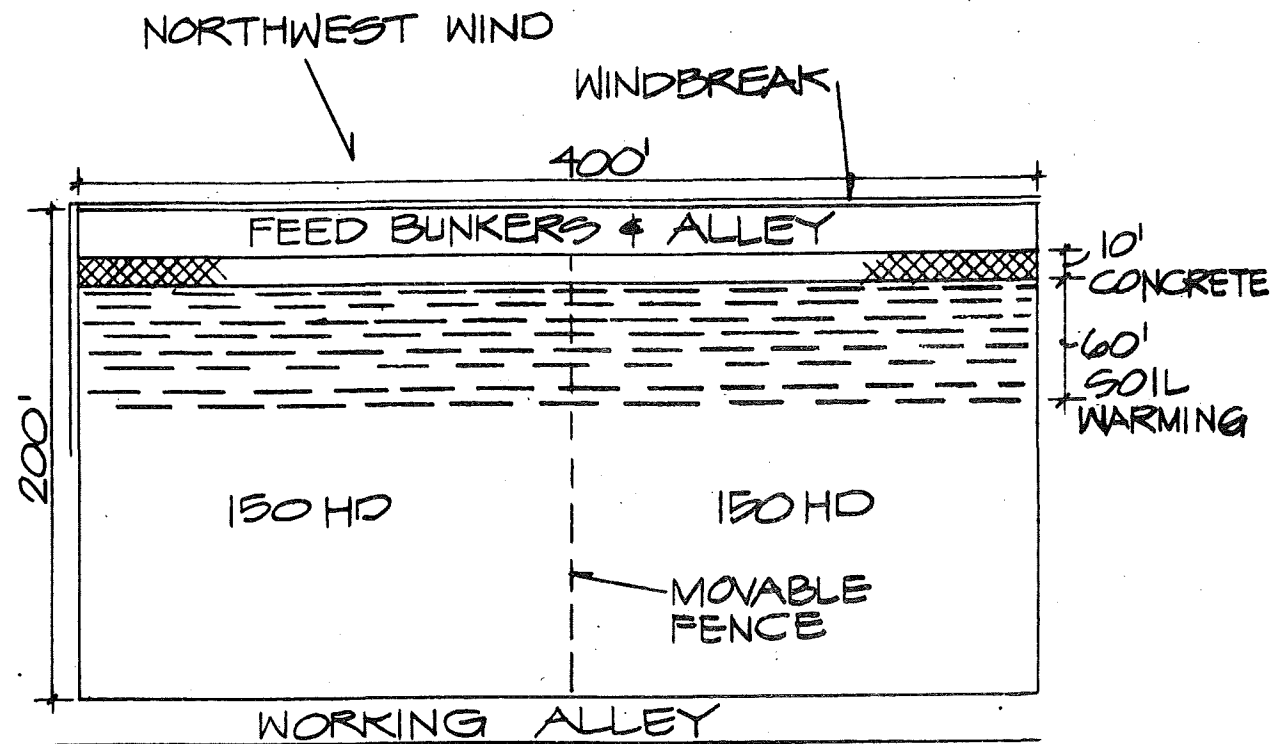

CAPACITY: FEEDER STEERS 650# - 400#
 GAIN 3.0 LBS PER DAY
 135 DAYS ON FEED

SINGLE COMPONENT FEEDLOT
UNIT - CAPACITY 600 HEAD
650 POUND FEEDER CATTLE

FIG. V-9

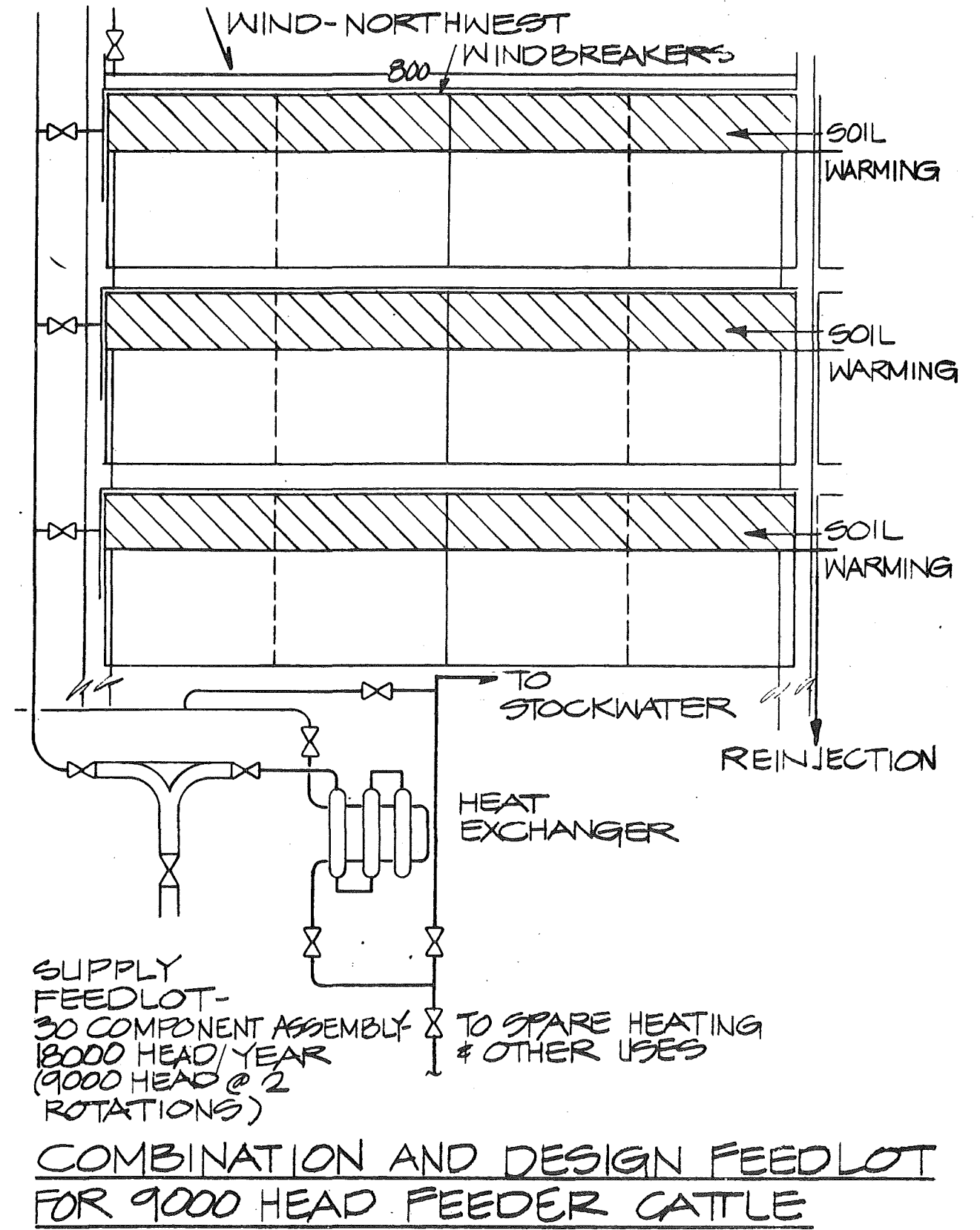

SUPPLY FEEDLOT -
 30 COMPONENT ASSEMBLY
 18000 HEAD/YEAR
 (9000 HEAD @ 2
 ROTATIONS)

COMBINATION AND DESIGN FEEDLOT
FOR 9000 HEAD FEEDER CATTLE

FIG. V-10

Of the 3.27 cent per pound cost attributed to facility costs, the cold weather equipment, consisting of the geothermal warming system and windbreaks, contributed 1.50 cents per pound.

Conclusions:

The use of geothermal energy would increase the efficiency of feedlots located in Lassen or Modoc County. While it would be moderately more costly to build and operate than a feedlot in a warm climate, it could, if operated as a cooperative, provide local ranchers with improved control of marketing operations and provide them the profits from feedlot fattening.

5. Aquaculture

Aquaculture was selected for analysis because it appeared to be ideal for application of geothermal heat. Warm ponds would allow year-round growth of food fish, a large variety of aquatic species would be available, and large amounts of low cost energy would be required. It appeared that geothermal energy might make practical the introduction of a major new industry to California. Closer analyses showed these presumptions, for the short-term view, to be overly optimistic. The species selected for analysis, while it brought a handsome market price, could not generate enough yield to pay for the heat. Other species, which could be grown at amazingly high yields, would not satisfy public tastes. Of the many varieties of aquatic animals suitable for farming on an industrial basis, several grow best in warm water in the range 65-85 degrees F. Among these are many species of carp, buffalo fish and paddle fish, catfish, labyrinth fishes, Tilapia, frogs, mullet, shrimp and prawns. Several can be grown in brackish water and in very high densities. Bardach¹⁹ (see Table V-8) lists the aquacultural yields of several selected species.

TABLE V-8

SELECTED EXAMPLES OF AQUACULTURAL YIELDS ARRANGED BY ASCENDING INTENSITY OF CULTURE METHODS

Culture Method	Species	Yield KG/HA(Year) or Economic Gain
Transplantation	Plaice (Denmark,1919-1957)	Cost: benefit of transplantation, 1:1.1-1.3 in best years (other social benefits)
	Pacific salmon (U.S.)	Cost: benefit, based on return of hatchery fish in commercial catch,1:2.3-5.1
Release of reared young into natural environment	Pacific salmon (Japan)	Cost: benefit 1:14-20, on above basis
	Shrimp, abalone, puffer fish (Japan)	Not assessed; reputed to increase income of fishermen
	Brown trout (Denmark, 1961-1963)	Maximum net profit/100 planted fish: 163%
Retention in enclosures of young or juveniles from wild populations, no fertilization, no feeding	Mullet	150-300
	Eel, miscell.fish (Italy)	1,250
	Shrimp (Singapore)	1,250
Stocking and rearing in fertilized enclosures, no feeding	Milkfish (Taiwan)	1,000
	Carp and related spp. (Israel,S.E. Asia)	125-700
	Tilapia (Africa)	400-1,200
	Carp (Java,sewage streams)	62,500-125,000

TABLE V-8 (continued)

SELECTED EXAMPLES OF AQUACULTURAL YIELDS ARRANGED BY ASCENDING INTENSITY OF CULTURE METHODS

Culture Method	Species	Yield KG/HA (year) or Economic Gain
Stocking and rearing with fertilization and feeding	Channel catfish (U.S.)	3,000
	Carp, mullet (Israel)	2,100
	Tilapia (Cambodia)	8,000-12,000
	Carp and related spp. (in polyculture--China, Hong Kong, Malaysia)	3,000-5,000
	Clarias (Thailand)	97,000
Intensive cultivation in running water; feeding	Rainbow trout (U.S.)	2,000,000 (170 kg/liter-sec) ^b
	Carp (Japan)	1,000,000 (about 100 kg/liter-sec)
	Shrimp (Japan)	6,000
Intensive cultivation of sessile organisms, mollusks and algae	Oysters (Japan, Inland Sea) ^a	20,000
	Oysters (U.S.)	5,000 (best yields)
	Mussels (Spain) ^a	300,000
	Porphyra (Japan) ^a	7,500
	Undaria (Japan) ^a	47,500

^a Raft-culture calculations based on an area 25% covered by rafts.

^b See text for volume of flow versus surface as basis of yield.

Of the suitable aquatic species available, *Macrobrachium rosenbergii*, a giant freshwater prawn native to Southeastern Asia, was selected for analysis. This prawn has been successfully cultured in the orient since 1969²⁰ and today is being raised in ponds in Florida, Hawaii, California, Puerto Rico and Panama and in the warm water effluent from a power plant in New Jersey. The current literature^{19, 20, 21, 22, 23, 24} is replete with descriptive studies and analytical research on this animal. The principal reason for selecting it, however, was its high degree of marketability compared to most other aquatic food fish. On today's market, shrimp are sold retail at prices from three dollars per pound for small to over six dollars per pound for the larger species. *Macrobrachium rosenbergii* would fall in the latter category and be marketed at between three and six to the pound.

The case against the common carp, at least for the short-term, and other similar highly nutritional fishes, is stated succinctly by Bardach et al¹⁹:

"Price and prejudice went hand in hand, so that today in North America carp bring only a third the price of such comparable 'rough' fish as buffalo fish. Some carp are marketed by commercial fisherman, but sales are virtually limited to the poorest members of society.

With the continued eutrophication of American waters and the predicted narrowing of the gap between protein supply and demand, sport and commercial fishermen, fish culturists, and housewives may all have to reconsider the carp. For the present, however, carp are scarcely considered edible in North America and their culture is not economically feasible."

Maximum length for *Macrobrachium rosenbergii* is about 25 cm for males and 15 cm for females. Both sexes bring extremely high prices relative to other fish. In nature adult *Macrobrachium rosenbergii* are found in virtually all types of fresh and brackish water. Larval development, however, requires 8 to 22 percent salinity¹⁹. In nature a single female may spawn three to four times each year, producing up to 120,000 eggs each time. Incubation requires 26° C (78.8° F) to 28° C (82.3° F). Over a period of 35 to 55 days, the larvae pass through 12 stages and metamorphose into juveniles. Juveniles adopt a benthic mode of life and feed on benthic animals and organic detritus.

During their early life the larvae diet is specific; they are fed brine shrimp nauplii. As they metamorphose to juveniles, their diets change and vitamin-fortified mixtures of fish flesh and egg custard, powdered dried chicken blood and phytoplankton have all been successfully used. The growing juveniles can be fed fresh fish, mollusks and earthworms cut into pieces according to the size of the juveniles. These can be supplemented with dried animal matter, grain, peas, beans and soft aquatic plants. Use of prepared feeds requires that uneaten food and fecal matter be siphoned out daily and that the water be changed frequently.

When they reach about four cm in length, the young prawns are suitable for stocking in fresh water ponds. "Almost any sort of pond over 200 m² in surface area and 50 cm in depth, with a water temperature of 22 to 32° C (71.6 to 89.6° F) can be used for growing *Macrobrachium rosenbergii*, but larger ponds, 1000 square meters or more in area and 1 to 1.5 meters deep, are more economical."¹⁹

Prawns may be stocked alone or in combination with fish (see Table 19 V-9). Knight, however, recommends that initial adventures into prawn aquaculture be limited to single species in small ponds to prevent the spreading of communicable diseases. Natural production within the ponds should supply most of the food. Supplementary foods can include cow dung mixed with lime, animal matter, fish, mollusks, earthworms, offal, live insects, various grains and rotten fruit. Five percent of the total body weight of prawns should be fed daily.

TABLE V-9

STOCKING RATES FOR GIANT FRESHWATER PRAWNS (*Macrobrachium rosenbergii*) CULTURED AND WITH FISH IN SOUTHEAST ASIA

Pond Conditions	Stocking Rate (Prawns/HA)	Stocking Rate of Fish
Prawns Cultured Alone		
Rich	15,000	
Medium	10,000	
Poor	6,000	
Prawns Cultured With Fish		
Rich	6,000	Full
	12,000	Half
Medium	4,000	Full
	8,000	Half
Poor	2,000	Full
	4,000	Half

Two problems generally encountered in prawn culture are oxygen depletion and cannibalism. Normally, sufficient oxygen can be provided if the throughput is high and if the water is aerated over a rough surface before it enters the pond. When oxygen becomes deficient the prawns migrate to the edges of the ponds and their activity becomes sluggish. Prawns are cannibalistic, more so when overcrowded. They are especially vulnerable when moulting. When a number of females are kept in a tank, a male, if present, will protect a moulting female from attack. One male can protect five or six females²². Cannibalism is also reduced by providing natural hiding places by growing small patches of *Ipomoea* in the pond (10 percent maximum pond coverage) and by placing branches on the bottom of the pond.

Macrobrachium rosenbergii were experimentally reared through all larval stages by Ling and Merican at Penang, Malaysia, and later by Fujimura in Hawaii²². Currently prawn aquaculture research and development and pilot-scale activities in the U.S. are underway in Hawaii, California, Florida, North Carolina and elsewhere.

Knight²⁵ noted that raising prawns is complex and not for the amateur. He recommended that an entrepreneur, before deciding to invest in prawn aquaculture, should be ready to operate without profit during the first two years. During this time period, he would require professional training and would learn the many nuances of this sophisticated business necessary to bring a successful crop to market. He also recommended that geothermal water be used as an indirect heat source and that only potable water be used in direct contact with the prawns so that dangers of disease and concentration of dangerous chemicals in the animals' organs be minimized. Goodwin and Hanson²² also warned of deposits of calcium carbonate from saline solutions on the prawn carapace at high pH. However, Johnson,²⁰ at the Oregon Institute of Technology, is experimenting with direct use of geothermal water with some success.

Disease generally is not considered a major obstacle to prawn culture.²² Wipeouts can be reduced or eliminated by alertness of the operator in reporting diseases to a pathologist to identify cures and provide preventive measures.

Pond Production

After accounting for the shorter growing season in South Carolina it may be seen that annual production rates for different locations are similar:

PRAWN (*Macrobrachium rosenbergii*) PRODUCTION RATES

Location	Ref.	Production Rate (annual)	
		Kg/ha	lb/Ac.
South Carolina	23	(1) 1000-2000	890-1790
Hawaii	22		
Ota's Ponds		(2) 3360	3000
Kato's Fish Farms		3240	2890

(1) When stocked with large juveniles of .25 gm or greater weight; five-six month growing season.

(2) Stocking rate of 1.5 juveniles per square foot.

With geothermal energy enabling ideal temperature conditions year-round, one would anticipate greater yields than those tabulated.

Marketing

Prawns would probably move into markets with other high value crustaceans such as lobsters, crabs and shrimp. Currently, they are mostly sold as whole animals with heads on, but for stronger competition they would probably be sold as tails and could be marketed in sizes from those comparable to Gulf Coast shrimp to larger sizes, four to six to the pound.

Hawaiian experience indicates the cost of raising prawns to marketable size is about two dollars per pound.²² Feed costs were about 42 cents. Labor costs ran 30 to 40 percent of grow-out costs. Approximate costs estimated from various data sources (1974) are listed below.

APPROXIMATE COSTS OF RAISING PRAWNS

	\$ per pound of Product
Feed	\$.40 - \$.50
Labor	\$.60 - \$.80
Stock (Larvae)	\$.06 - \$.10
Operating Cost	\$1.00 - \$1.40

Capital costs in Puerto Rico²² ran 3,556 dollars per acre based on 36 one-acre ponds, each on 1.5 acres of land.

It was initially presumed that application of geothermal energy to prawn aquaculture would increase capital costs but allow higher operating efficiency through ideal temperature control of the water and year-round growing season in Lassen and Modoc Counties. Analysis proved this presumption false.

Figure V-11 illustrates a flow chart for geothermally heated ponds. It is based on a one-acre by three foot deep pond, 20° F air temperature with a wind velocity of five miles per hour. A windbreak is located alongside to prevent heat losses during high wind periods. Nevertheless, preliminary design heat loss calculations indicate losses will be quite high, so that during cold weather each acre of pond requires one well supplying 260 gpm at 200° F. Heating costs would amount to about 10,000-15,000 dollars per year, including the cost of the potable water heaters and the supply and reinjection wells. Based on production rates in Hawaii, say 3000 pounds per acre, this would amount to three to five dollars per pound of product, too high a cost to justify the use of geothermal energy. The cost of conventional fuel would be 30 to 40 dollars a pound. Use of a low cost air supported cover of the ponds to reduce energy losses was considered, but the high condensation rates left technical feasibility in doubt and the cost of the cover exceeded the energy savings.

The only conclusion that can be drawn is that prawn aquaculture is not profitable enough to support even an inexpensive heating system in Lassen or Modoc Counties. Until the intensity of prawn production can be increased by nearly an order of magnitude (while maintaining market prices), geothermal energy cannot be economically applied.

Other aquatic species, i.e., carp, have yielded 0.9 to 3.6 million pounds per acre; but as was shown by Bardach¹⁹, the American market is not yet ready.

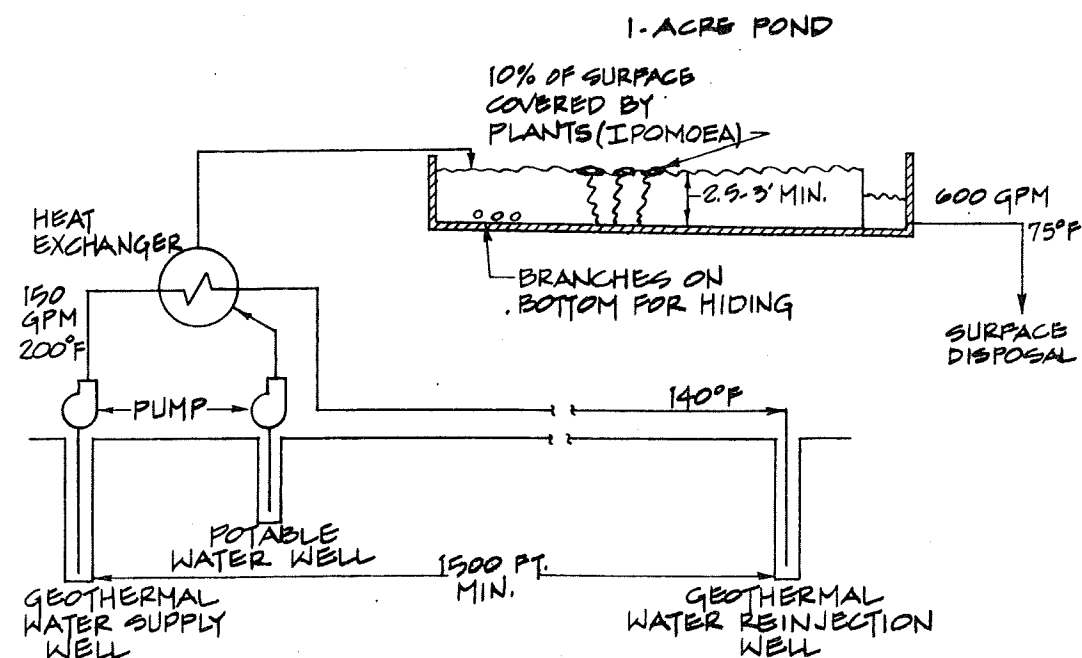

GEOTHERMAL HEATING SYSTEM FOR 1 ACRE AQUACULTURE POND
PRAWNS (*MACHROBACHIUM ROSENBERGI*)

FIG. V-11

More recent evidence that the palate of Americans has not changed is evidenced in an article in *The Wall Street Journal*, dated September 20, 1976, and misleadingly titled "Freshwater-Rough Fish Are Winning More Acceptability on U.S. Dinner Tables." The article cites prices at a major Chicago fish market as follows: Popular varieties of fish--Whitefish and Red Snapper, \$1.25 a pound; filleted yellow perch, \$3.50 a pound. Rough fish varieties (i.e., warm water fish), boned buffalo fish, 45 cents a pound; sheepshead, 20 to 25 cents a pound; and carp, 10 to 12 cents a pound. The article goes on to say that a large cannery that so far has rejected the bait is Libby, McNeil & Libby, Inc. It decided against canning carp and tuna-type products because it projected high promotional and advertising costs."

Channel catfish, considered a delicacy in the southeastern states, is another warm water fish which has potential. Bardach¹⁹ (1972) notes that, "Present indications are that economic prognosis for new catfish farmers is getting poorer," but changing markets and more efficient production through use of geothermal water might alter this.

The case for geothermally heated aquacultural products should not be closed, however. The marketing views presented here were based on the assumption that geothermal water could not be used in direct contact with aquatic animals and considered only food products for human consumption in the United States. Direct growth in geothermal water, if proven safe, would bring about a large reduction in production costs. Changes in tastes for species which can be intensively grown could provide a major new market. Production for overseas human consumption or for local use as fertilizers or animal feeds are alternatives which have potential but which were not analyzed.

Over the long run, the ability of aquacultural systems to efficiently generate high quantities of high quality low cost protein is certain to predominate over temporary whims of palate. The capability of such systems to consume waste in symbiotic biological group, i.e., manure for fish feed generated in a geothermal multi-use arrangement with a feedlot and downstream fish pond, could provide additional efficiencies and ease environmental disposal problems.

APPENDIX

VI A
APPENDIX

Demographic and Economic Profile

Modoc and Lassen Counties

Population

Historical population levels have shown erratic trends in both counties. Table shows historical population for both counties for decadal periods, 1920-1970.

Table A-1
Historical Population
Modoc and Lassen Counties

	1920	1930	1940	1950	1960	1970	1976 ^E
Modoc	5,425	8,038	8,713	9,678	8,308	7,469	8,400
Lassen	<u>8,507</u>	<u>12,589</u>	<u>14,479</u>	<u>18,474</u>	<u>13,597</u>	<u>14,960</u>	<u>17,000</u>
Total	13,932	20,627	23,192	28,152	21,905	22,429	25,400

The significant decline in population in the 1950's is attributed to economic reasons. The large emigration that occurred was in direct response to the lack of jobs in both counties. Recent growth has been urban in nature, and is generally indicative of a growing retirement age population.

The losses in population have occurred mostly in labor age groups. Tables 2 and 3 show the relative change in different population age groups for both counties. It is also interesting to note that the population group 20-24 increased dramatically in Lassen County between 1960 and 1970--an indication of the shift of young persons mainly from cities to rural areas.

TABLE A-2
 MODOC COUNTY POPULATION BY AGE GROUPINGS
 1950, 1960 and 1970

	1950		1960		1970		California % of total	Percent change 1950-70
	Number	% of Total	Number	% of Total	Number	% of Total		
Under 5 years	1,206	12.51	848	10.21	495	6.62	8.21	-59.0
5 to 9 years	850	8.82	963	11.59	679	9.09	9.65	-20.1
10 to 14	673	6.98	902	10.86	767	10.27	9.84	14.0
15 to 19	567	5.88	537	6.46	704	9.43	9.17	24.2
20 to 24	677	7.02	352	4.24	397	5.32	8.60	-41.4
25 to 34	1,696	17.60	940	11.32	811	10.86	13.35	-52.2
35 to 44	1,449	14.62	1,210	14.56	833	11.15	11.86	-42.5
45 to 54	1,138	11.81	1,025	12.34	1,018	13.63	11.64	-10.5
55 to 59	451	4.68	428	5.15	475	6.36	4.69	5.3
60 to 64	350	3.63	336	4.04	398	5.33	3.88	13.7
65 to 74	419	4.35	511	6.15	575	7.70	5.55	37.2
75 and over	202	2.10	256	3.08	317	4.24	3.50	56.9
TOTAL	9,678	100.0	8,308	100.0	7,469	100.0	100.0	-22.8

Source: U.S. Bureau of the Census, U.S. Census of Population, 1950, 1960 and 1970, California General Social and Economic Characteristics.

TABLE A-3
 LASSEN COUNTY POPULATION
 BY AGE GROUPINGS
 1950, 1960 and 1970

	1950		1960		1970		Percent change 1950-70
	Number	% of Total	Number	% of Total	Number	% of Total	
Under 5 years	2,370	12.8	1,394	10.3	1,152	7.7	-51.4
5 to 9 years	1,834	9.9	1,477	10.9	1,340	9.0	-26.9
10 to 14	1,465	7.9	1,443	10.6	1,571	10.5	7.2
15 to 19	1,288	7.0	958	7.0	1,490	9.9	15.7
20 to 24	1,405	7.6	583	4.3	1,089	7.3	-22.5
25 to 34	3,111	16.8	1,580	11.6	1,631	10.9	-47.6
35 to 44	2,685	14.6	1,925	14.2	1,825	12.2	-32.0
45 to 54	1,969	10.7	1,745	12.8	1,970	13.2	0.1
55 to 59	723	3.9	667	4.9	846	5.6	17.0
60 to 64	629	3.4	592	4.4	688	4.6	9.4
65 to 74	707	3.8	862	6.3	869	5.8	22.9
75 and over	288	1.6	371	2.7	489	3.3	69.8
Total	18,474	100.0	13,597	100.0	14,960	100.0	-19.0

Source: U.S. Bureau of the Census, U.S. Census of Population 1950, 1960 and 1970, California General Social and Economic Characteristics.

Employment

In 1970, the greatest area of employment in both Lassen and Modoc Counties was the service sector, with 76.4 and 58.6 percent of the total employment population providing service jobs, respectively. Of significance, service jobs have increased most rapidly of all occupations, while farming and manufacturing employment has declined substantially. The gain in service employment has been almost entirely governmental. Tables 4 and 5 show employment by occupation for Modoc and Lassen Counties, respectively, by decade since 1950.

Employment in both counties is highly seasonal, with wide variations between high summer and low winter employment. The categories of employment accounting for the major portion of this difference are related to seasonal demands in the lumber and agriculture industries. Annual unemployment rates since 1960 are shown in Table 6 for both counties. There has been a marked increase in unemployment since 1970. In early 1975 the unemployment rate was a staggering 26.4 percent. This tremendous seasonality reflects the severe degree of underemployment in the region.

Major employment cutbacks in the Sierra Army Depot and significant lumber market fluctuations beginning in about 1973 had a major effect on the unemployment rate of Lassen County. The lower unemployment rates in Modoc County are primarily due to the county's larger agricultural base, and lesser dependence on the lumber industry compared to that of Lassen County. The increase in unemployment in Modoc County during 1976 was the result of market demand and drought effects.

Tables 7 and 8 delineate experience information on those unemployed in 1972 by occupation. A large percentage of the total unemployed are classified as craftsman, foremen and kindred workers. Total blue collar workers for both counties constitute about 60 percent of the unemployed work force.

TABLE A-4
MODOC COUNTY EMPLOYMENT BY MAJOR CATEGORIES
1950, 1960 and 1970

	(1950)			(1960)			(1970)		
	Number Employed	% Employed of Total Employment Population	Number Employed	% Employed of Total Employment Population	Number Employed	% Employed of Total Employment Population	Number Employed	% Employed of Total Employment Population	
Agriculture Forestry & Fisheries	1,194	32.0%	998	31.3%	772	26.5%	772	10.3%	
Mining & Construction	276	7.4%	182	5.7%	179	6.1%	179	2.4%	
Manufacturing	739	19.8%	393	12.3%	257	8.8%	257	3.4%	
Service	1,526	40.8%	1,611	50.7%	1,709	58.6%	1,709	22.9%	
Total Employment	3,735	100.0%	3,184	100.0%	2,917	100.0%	2,917	39.0%	
Total Population	9,678		8,308		7,469		7,469		

Source: 1950, 1960 and 1970 data are from U.S. Census of Population.

TABLE A-5
 LASSEN COUNTY EMPLOYMENT BY MAJOR CATEGORIES
 1950, 1960 and 1970

	(1950)		(1960)		(1970)	
	Number Employed	% Employed of Total Employment Population	Number Employed	% Employed of Total Employment Population	Number Employed	% Employed of Total Employment Population
Agriculture, Forestry and Fisheries	705	10.7	562	11.7	528	10.1
Mining and Construction	234	3.6	190	4.0	226	4.3
Manufacturing	1,997	30.4	893	18.7	483	9.2
Service	3,633	55.3	3,133	65.6	3,995	76.4
Total Employment	6,569	100.0	4,778	100.0	5,232	100.0
Total Population	18,474		13,597		14,960	

Source: 1950, 1960 and 1970 data are from U.S. Census of Population.

TABLE A-6
 HISTORICAL UNEMPLOYMENT RATES (%)
 MODOC AND LASSEN COUNTIES

YEAR	MODOC			LASSEN			CALIF.
	Low	Yearly Average	High	Low	Yearly Average	High	Yearly Average
1970	3.8 (Oct)	6.7	11.5 (Dec)	6.5 (Oct)	10.9	16.1 (Feb)	7.3
1971	3.7 (Sept)	7.9	14.3 (Jan)	7.4 (Sept)	11.4	18.1 (Mar)	8.8
1972	3.6 (Aug)	7.1	15.3 (Feb)	7.0 (Oct)	11.5	18.5 (Jan)	7.6
1973	5.9 (Aug)	9.7	14.1 (Dec)	8.7 (Sept)	16.9	25.7 (Feb)	7.0
1974	7.3 (Jul)	10.5	14.7 (Jan)	10.2 (Oct)	17.4	25.2 (Feb)	7.3
1975	7.8 (Oct)	11.9	17.6 (Feb)	13.3 (Sept)	19.8	26.4 (Feb)	9.9
1976	8.8 (May)	12 ^E	17.3 (Jan)	11.1 (Jul)	19 ^E	26.0 (Feb)	8.0 ^E

Source: State of California, Employment Development Department, Employment, Data and Research Division

TABLE A-7
EXPERIENCED UNEMPLOYED BY OCCUPATION
MODOC COUNTY -- 1972

Experienced Unemployed Population	Total	% of Total Experienced Unemployed
Total All Occupations - Both Sexes	171	100.0
White Collar Occupations - Total	36	21.0
Professional, Technical and Managerial Workers	22	12.9
Sales Workers	0	0
Clerical Workers	14	8.2
Blue Collar Occupations - Total	103	60.2
Craftsmen, Foremen and Kindred Workers	57	33.3
Operatives including transport Laborers Except Farm	23	13.5
Farm Occupations	23	13.5
Service Occupations - Total	11	6.4
Service Workers Except Private Household	21	12.3
Private Household Workers	0	0
Total All Occupations - Male	121	70.8
White Collar Occupations - Total	16	9.4
Professional, Technical and Managerial Workers	16	9.4
Sales Workers	0	0
Clerical Workers	0	0
Blue Collar Occupations - Total	90	52.6
Craftsmen, Foremen and Kindred Workers	57	33.3
Operatives including transport Laborers Except Farm	14	8.2
Farm Occupations	19	11.1
Service Occupations - Total	11	6.4
Service Workers Except Private Household	4	2.3
Private Household Workers	4	2.3
Total All Occupations - Female	50	29.2
White Collar Occupations - Total	20	11.7
Professional, Technical and Managerial Workers	6	3.5
Sales Workers	0	0
Clerical Workers	14	8.2
Blue Collar Occupations - Total	13	7.6
Craftsmen, Foremen and Kindred Workers	0	0
Operatives Including Transport Laborers Except Farm	9	5.3
	4	2.3

TABLE A-8
EXPERIENCED UNEMPLOYED BY OCCUPATION
LASSEN COUNTY -- 1972

Experienced Unemployed Population	Total	% of Total Experienced Unemployed
Total All Occupations - Both Sexes	663	100.0
White Collar Occupations - Total	117	17.6
Professional, Technical and Managerial Workers	44	6.6
Sales Workers	9	1.4
Clerical Workers	64	9.6
Blue Collar Occupations - Total	424	63.9
Craftsmen, Foremen and Kindred Workers	154	23.2
Operatives Including Transport Laborers Except Farm	76	11.5
Farm Occupations	194	29.3
Service Occupations - Total	27	4.1
Service Workers Except private Household	90	13.5
Private Household Workers	76	11.5
	14	2.1
Total All Occupations - Male	470	70.9
White Collar Occupations - Total	34	5.1
Professional, Technical and Managerial Workers	18	2.7
Sales Workers	0	0
Clerical Workers	16	2.4
Blue Collar Occupations - Total	395	59.6
Craftsmen, Foremen and Kindred Workers	144	21.7
Operatives Including Transport Laborers Except Farm	71	10.7
Farm Occupations	180	27.1
Service Occupations - Total	22	3.3
Service Workers Except Private Household	19	2.7
Private Household Workers	19	2.7
	0	0
Total All Occupations - Female	193	29.1
White Collar Occupations - Total	83	12.5
Professional, Technical and Managerial Workers	26	3.9
Sales Workers	9	1.4
Clerical Workers	48	7.2
Blue Collar Occupations - Total	29	4.4
Craftsmen, Foremen and Kindred Workers	10	1.5
Operatives Including Transport Laborers Except Farm	5	.7
	14	2.1

Income

Family income for both counties and California for the years 1950, 1960 and 1970 are shown in Tables 9 and 10. The median family income for both counties in 1950 was about the statewide average, however by 1970 both counties had fallen behind the statewide average. Tables 11 and 12 show personal income by major source. Wages and salaries remain the greatest source of income; however, transfer payments (Social Security, pensions or annuity incomes) have steadily increased in Lassen County, but have only remained constant in Modoc County.

Table A-9
FAMILY INCOME: LASSEN COUNTY AND CALIFORNIA, 1950, 1960 and 1970

	Lassen County			California		
	1950	1960	1970	1950	1960	1970
	<u>Number</u>					
All Families	4,590	3,577	4,175	2,827,110	5,559,955	5,001,255
Under \$1,000	230	105	55	260,650	525,707	111,268
\$1,000 to \$1,999	295	211	98	302,055	569,390	116,312
\$2,000 to \$2,999	740	204	184	437,560	434,146	176,746
\$3,000 to \$3,999	1,480	270	212	581,615	454,351	215,158
\$4,000 to \$4,999	710	480	209	408,545	501,403	222,202
\$5,000 to \$5,999	390	602	287	267,860	559,411	242,986
\$6,000 to \$6,999	205	470	284	159,990	530,240	264,960
\$7,000 to \$7,999)	303	330)	441,639	293,660
\$8,000 to \$8,999) 295	276	329) 181,975	355,633	312,881
\$9,000 to \$9,999)	214	402)	274,836	311,639
\$10,000 to \$14,999)	395	1,095)	635,785	1,398,973
\$15,000 to \$24,999) 125	26	598) 101,845	199,323	1,029,394
\$25,000 and over)	21	92)	78,091	305,076
Unreported	120	--	--	125,015		
<u>Median income</u>						
Families	\$3,602	\$5,861	\$9,248	\$3,585	\$6,726	\$10,732
Unrelated Individuals	--	\$2,436	\$2,683	\$1,279	\$2,037	\$ 3,221
Families and unrelated Individuals	\$3,301	\$5,298	\$5,712	\$3,021	\$5,527	\$8,279

Sources: U.S. Bureau of the Census, 1950 Census of Population, Vol. II, Characteristics of the Population, Part 5, California, pp. 5-71 and 5-176. U.S. Census of Population 1960, California, General Social and Economic Characteristics, PC(1) 6C California, pp. 6-435. U.S. Bureau of the Census, 1970 Census of Population, General Social and Economic Characteristics, California.

TABLE A-10
FAMILY INCOME: MODOC COUNTY AND CALIFORNIA
1950, 1960 & 1970

	Modoc County				California			
	1950	1960	1970	%	1950	1960	1970	%
All Families	2,170	2,238	2,072	100	2,827,110	5,559,995	5,001,225	100
Under 1,000	170	70	33	2	260,650	525,707	111,268	2
(1,000 to 1,999	210	166	64	3	302,055	569,390	116,312	2
\$2,000 to 2,999	385	197	124	6	437,560	434,146	176,746	4
\$3,000 to 3,999	365	186	182	9	581,615	454,351	215,158	4
\$4,000 to 4,999	295	264	178	9	408,545	501,403	222,202	4
\$5,000 to 5,999	245	289	139	7	267,860	559,411	242,986	5
\$6,000 to 6,999	130	251	90	4	159,990	530,240	264,960	5
\$7,000 to 7,999)	177	129	6)	441,639	293,660	
\$8,000 to 8,999)	125	205	10)	181,795	312,881	6
\$9,000 to 9,999)	126	124	6)	274,836	311,639	6
\$10,000 to 14,999)	277	508	25)	635,785	1,398,973	28
\$15,000 to 24,999)	40	240	12)	101,845	1,029,394	21
\$25,000 & over)	23	56	3)	78,091	305,076	6
Unreported	205				125,015			
Mean Income			\$9,322				\$ 12,227	
Median Income								
Families	\$3,483	5,709	8,473		3,585	6,726	10,732	
Unrelated Individuals		1,882	2,587		1,279	2,037	3,221	
Families & Unrelated Individuals	2,895	4,995	6,890		3,021	5,527	8,279	

Source: U.S. Bureau of the Census, Census of Population, 1950, 1960 & 1970, California General Social & Economic Characteristics "Selected Economic Data" Lassen County, California, Agricultural Extension, University of California.

TABLE A-11
LASSEN COUNTY: PERSONAL INCOME BY MAJOR SOURCE
SELECTED YEARS 1950-1969

Year	Total Income \$1,000	Wages and Salaries*		Other Labor Income		Proprietor's Income		Property Income		Transfer Payments		
		Per- cent	\$1,000	Per- cent	\$1,000	Per- cent	\$1,000	Per- cent	\$1,000	Per- cent	\$1,000	Per- cent
1950	31,048	100.0	21,087	67.9	489	1.6	5,032	16.2	2,087	6.7	2,353	7.6
1955	31,816	100.0	21,855	68.7	655	2.0	5,254	16.5	1,641	5.2	2,411	7.6
1960	28,800	100.0	18,900	65.6	500	1.8	4,100	14.2	2,100	7.3	3,200	11.1
1961	32,526	100.0	20,867	64.1	978	3.0	4,931	15.2	1,942	6.0	3,808	11.7
1962	35,964	100.0	21,640	60.2	917	2.5	5,207	14.5	3,986	11.1	4,214	11.7
1963	36,868	100.0	24,675	66.9	1,070	2.9	1,970	5.4	4,209	11.4	4,944	13.4
1964	44,340	100.0	24,574	55.4	1,120	2.5	7,955	17.9	5,432	12.3	5,259	11.9
1965	40,156	100.0	25,997	64.7	658	1.6	4,866	12.1	3,774	9.4	4,891	12.2
1966	44,963	100.0	30,132	67.0	733	1.7	4,954	11.0	3,968	8.8	5,176	11.5
1967	47,391	100.0	31,363	66.2	773	1.6	5,144	10.9	4,188	8.8	5,923	12.5
1968	50,136	100.0	32,751	65.3	771	1.6	5,532	11.0	4,418	8.8	6,664	13.3
1969	53,500	100.0	34,100	63.7	800	1.5	5,500	10.3	4,800	9.0	8,300	15.5

* Less personal contributions for social insurance.

Source: Economic Survey Series, California Chamber of Commerce, Research Dept.

TABLE A-12

MODOC COUNTY: PERSONAL INCOME BY MAJOR SOURCE
SELECTED YEARS 1960 THROUGH 1968

Year	Total Income \$1,000	Wages & Salaries* \$1,000	%	Other Labor Income \$1,000	%	Proprietor's Income \$1,000	%	Property Income \$1,000	%	Transfer Payments \$1,000	%
1960	20,588	9,704	47.1	361	1.8	6,823	33.1	1,809	8.8	1,891	9.2
1961	20,393	10,287	50.4	428	2.1	5,730	28.1	1,878	9.2	2,070	10.2
1962	19,116	8,128	42.5	351	1.8	6,817	35.7	1,813	9.5	2,007	10.5
1963	17,747	8,728	49.2	386	2.2	4,540	25.6	1,976	11.0	2,117	12.0
1964	20,198	9,339	46.2	419	2.1	5,336	26.4	2,885	14.3	2,219	11.0
1965	21,573	10,493	48.6	386	1.8	5,886	27.3	2,658	12.3	2,150	10.0
1966	22,976	10,827	47.1	397	1.7	6,544	28.5	2,717	11.8	2,491	10.9
1967	25,825	12,023	46.6	479	11.9	7,340	28.4	2,953	11.4	3,030	11.7

*Less personal contributions for social insurance.

Source: California State Chamber of Commerce, "Economic Survey Series"

Tables 13 through 16 show historical agricultural, mineral and lumber valuation data for both counties. The agricultural base in Modoc County is seen to be substantially greater than that for Lassen County, having a five-fold difference in total valuation. Timber production in Lassen County is erratic, but normally greater than Modoc County. Tables 17 and 18 show historical assessed valuation data for both counties, for the period 1940-1970, with the assessed valuation in Lassen County slightly higher than Modoc County.

TABLE A-13
 AGRICULTURAL PRODUCTION-VALUE AND RANK
 MODOC COUNTY, CALIFORNIA

PRODUCT	1962		1966		1970		1972	
	Value	% of Total	Value	% of Total	Value	% of Total	Value	% of Total
Beef	6,772,300	42.4	7,542,000	37.1	9,610,000	37.7	18,026,200	49.7
Alfalfa	1,128,600	7.1	1,497,000	7.4	3,219,000	12.6	4,883,300	13.5
Potatoes	2,412,000	15.1	5,400,000	26.5	5,280,000	20.7	5,600,000	15.4
Meadow Hay	1,492,800	9.3	1,605,000	7.9	2,898,000	11.4	2,924,100	8.1
Barley	1,304,200	8.2	1,820,000	8.9	1,260,000	4.9	1,732,000	4.8
Wheat	1,187,900	7.4	299,000	1.4	735,000	2.9	775,200	2.1
Oats	107,900	0.7	73,000	0.4	72,000	0.3	198,000	0.5
Grain Hay	115,500	0.7	410,000	2.0	335,000	1.3	315,000	0.9
Onions	511,360	3.2	753,000	3.7	1,000,000	3.9	629,900	1.7
Misc. Veg. Crops	50,400	0.3	170,000	0.8	450,000	1.8	540,000	1.5
Sheep & Lambs	356,800	2.2	367,000	1.8	398,000	1.6	316,800	0.9
Misc. Crops	82,000	0.5	128,000	0.6	-	-	-	-
Rye	57,600	0.4	4,500	0.0	-	-	119,700	0.3
Misc. Live./Live. Prod.	301,200	1.8	183,000	1.0	150,000	0.7	175,000	0.5
Wool	105,000	0.7	104,000	0.5	67,700	0.3	65,100	0.2
TOTAL	15,985,560	100%	20,355,500	100%	25,474,700	100%	36,300,300	100%

Source: Modoc County Agriculture Commissioner

TABLE A-14
 AGRICULTURAL PRODUCTION-VALUE
 LASSEN COUNTY

	1954	1959	1964	1969*
Vegetables	\$ 190	\$ 3,900	\$ 250	
Field crops	343,180	308,621	430,959	\$1,022,816
Fruits and nuts	694	203	19	
Livestock	2,970,862	4,131,654	3,785,926	
Poultry	87,019	59,239	34,251	6,003,263
Dairy	167,858	180,566	156,607	
Forest Products	85,230	52,905	93,610	215,476
Total	\$3,655,033	\$4,737,088	\$4,451,622	\$7,241,555

*1969 Figures are for Crops, Livestock Products and Forest Products.

Sources: U.S. Bureau of the Census, U.S. Census of Agriculture, 1954, Vol. 1, California, Counties.

U.S. Bureau of the Census, U.S. Census of Agriculture, 1959, Vol. 1, California, Counties.

U.S. Bureau of the Census, U.S. Census of Agriculture, 1964, Vol. 1, Part 48, California.

U.S. Bureau of the Census, U.S. Census of Agriculture, 1969.

TABLE A-15
 VALUE OF MINERAL PRODUCTS AND TIMBER
 PRODUCTION, MODOC COUNTY, 1950-1971

Year	Value of Mineral Products \$1,000	Timber Production Million Board Ft.
1950	202	222.6
1955	250	46.7
1960	584	42.3
1961	406	59.6
1962	968	60.3
1963	646	54.7
1964	614	48.5
1965	470	54.6
1966	540	91.8
1967	758	78.9
1968	496	85.2
1969		75.9
1970		99.4
1971		80.3

Source: California State Chamber of Commerce "Economic Survey Series"
 California Statistical Abstract
 U.S. Bureau of Mines: Mineral Yearbook

TABLE A-16
 VALUE OF MINERAL PRODUCTS AND TIMBER PRODUCTION
 LASSEN COUNTY, 1950-1968

Year	Value of Mineral Products \$1,000	Timber Production Million Board Ft.
1950	31	230.0
1955	306	256.8
1960	368	98.2
1961	789	121.1
1962	293	126.7
1963	272	78.9
1964	373	134.3
1965	n.a.	129.6
1966	623	111.0
1967	436	74.2
1968	1,197	88.6

Source: "Economic Survey Series", California State Chamber of Commerce.

TABLE A-17
 ASSESSED VALUATION OF COUNTY-ASSESSED TANGIBLE PROPERTY BY CLASS
 OF PROPERTY FOR LASSEN COUNTY, 1940-1970

	Land	Improvements	Personal Property*	Exemptions	Net Total
			\$1,000		
1940	6,856	3,282	2,141	176	12,103
1950	6,606	3,735	4,471	421	14,390
1955	6,237	4,424	4,439	677	14,423
1960	6,458	6,847	4,217	964	16,558
1961	6,630	6,958	4,114	977	16,725
1962	7,569	7,171	3,738	1,014	17,464
1963	7,628	8,149	3,913	1,164	18,526
1964	8,471	8,489	3,980	1,218	19,722
1965	8,751	9,021	4,105	1,221	20,656
1966	9,378	9,563	4,652	1,225	22,368
1967	10,758	10,739	4,884	1,171	25,210
1968	11,507	11,939	4,547	1,323	26,670
1969	12,979	12,542	4,419	1,179	28,761
1970	15,914	13,110	3,433	1,187	31,270

* Includes money not on deposit, 1940 through 1956 only.

Source: "Annual Report," California State Board of Equalization.

TABLE A-18
 ASSESSED VALUATION OF COUNTY--ASSESSED TANGIBLE PROPERTY
 BY CLASS OF PROPERTY FOR MODOC COUNTY, 1940 - 1970
 (\$1,000)

Year	Land	Improvements	Personal Property*	Exemptions	Net Total
1940	5,243	1,491	1,607	135	8,208
1950	4,274	2,381	4,796	225	11,226
1955	8,240	5,138	5,297	312	18,363
1960	8,429	5,808	5,313	391	19,159
1961	8,364	5,858	5,238	412	19,048
1962	8,370	6,379	4,805	455	19,099
1963	8,391	6,458	4,952	451	19,350
1964	8,968	6,583	4,719	445	19,825
1965	9,570	6,815	4,548	420	20,513
1966	10,731	6,960	4,821	411	22,101
1967	12,912	6,876	5,350	402	24,726
1968	14,012	6,907	4,668	381	25,206
1969	15,509	7,217	4,549	370	26,905
1970	17,812	7,304	2,938	354	27,700

* Includes money not on deposit, 1940-1956 only.

Source: "Annual Report", California State Board of Equalization

VI B

REFERENCES

1. ERDA Report SAN-1077-4, Susanville Geothermal Energy Project, Workshop Proceedings July 1976
2. The Potential of Low Temperature Geothermal Resources in California, Division of Oil and Gas, Geothermal Unit, Report No. TR 13.
3. Chemistry of Thermal Water in Selected Geothermal Areas of California, California Division of Oil and Gas, Report No. TR 15.
4. Dracup, J., et al, Waste Nutrient Recycling Using Hydroponic Aquacultural Methods, University of California, 1975.
5. Geo-Heat Utilization Center, Quarterly Bulletin, July 1976, Oregon Institute of Technology.
6. California Public Utilities Commission, personal interview and telephone conversations to obtain shipping rates.
7. Southern Pacific Railroad Advertisement in Traffic Management Magazine, Spring 1976.
8. Chicken Fryer Production: Management, Costs and Returns, Division of Agricultural Sciences, University of California, Leaflet 2648.
9. Conceptual Study for Total Utilization of an Intermediate Temperature Geothermal Resource; ANCR-1260, UC-66, INEL.
10. Wartes, Lloyd, The Solar Greenhouse: A Means to Increased Food Production, Solar Engineering, October 1976.
11. Crop Processes in Controlled Environments, Proceedings of International Symposium held at Glasshouse Crops Research Institute, Little Hampton, Sussex, England, July 1971. Edited by A.R. Rees, K.E. Cockshull, D.W. Hand and R.G. Hurd.
12. Cow-Calf, Economics, Cecil Pierce, Modoc County Farm Advisor, Proceeding: Klamath, Lake, Modoc, Stockman's Day.
13. Young, B.A., A practical Method for Calculating Cold Stress in Cattle. University of Alberta, Canada, Feeders' Day 1971.
14. Young, B.A. and Christopherson, R.J., Effect of Prolonged Cold Exposure on Digestion and Metabolism in Ruminants, American Society of Agricultural Engineers, Livestock Environment Proceeding of the International Livestock

17. Barrette, B.R., Lucke, D.R., The Forest Resources in the Timber Industry of the North Cal-Neva Resource Conservation and Development Project, Joint Study, California Division of Forestry, U.S. Forest Service, Soil Conservation Service, 1975.
18. Kiln-Drying Western Softwoods, Moore Dry Kiln Company, North Portland, Oregon.
19. Bardach, J.E., Ryther, J.H., and McLarney, W.O., Aquaculture, the Farming and Husbandry of Freshwater and Marine Organisms, Wiley Interscience 1972.
20. Johnson, B., Aquaculture at Oregon Institute of Technology, Geo-Heat Utilization Center Quarterly Bulletin, Oregon Institute of Technology, July 1976.
21. Knight, Allen, and others, Laboratory Studies on Selected Nutritional, Physical and Chemical Factors Affecting the Growth Survival, Respiration and Biogenetics of the Giant Prawn, Macrobrachium rosenbergii, Hydrobiology Laboratory, Department of Water Science and Engineering, University of California, Davis, March 1976.
22. Goodwin, H.L., and Hanson, J.A., The Aquaculture of Freshwater Prawns (Macrobrachium species), the Oceanic Institute, Waimaualo, Hawaii, 1975.
23. Sandifer, P.A., and Smith, T.I., Experimental Aquaculture of the Malaysian Prawn, Macrobrachium rosenbergii (DeMan) in South Carolina, U.S.A., Food and Agriculture Organization of The United Nations, Rome, Italy, 1976.
24. Sandifer, P.A., Smith, T.I., Development of a Crustacean Mariculture Program at South Carolina's Marine Resources Research Institute, Proceedings of Fifth Annual Workshop, World Mariculture Society, 1974.
25. Knight, Dr. W. Allen, personal interview at U.C. Davis.
26. Wall Street Journal, Sept. 20, 1976, Commodities--"Freshwater 'Rough' Fish Are Winning More Acceptability at U.S. Tables."
27. Geothermal Related Corrosion Testing, Silva, J., Geo-Heat Utilization Bulletin, Oregon Institute of Technology, October 1975.
28. Lindal, B., Industrial and other Applications of Geothermal Energy, UNESCO 1973 Geothermal Energy (Earth Sciences, 12).
29. They're not 'biting' at his bark, Chemical Week, December 22, 1976.