

BACA PROJECT

DATA AND REPORTSGEOLOGY

<u>No.</u>	<u>Transfer Date</u>	<u>Release Date</u>	<u>Title</u>
1.	B	B	Hydrothermal Geology of the Valles Caldera, New Mexico by R.F. Dondanville - 1971.
2.	B	B	Airborne Infrared Geothermal Exploration-- Valles Caldera, New Mexico Earth Resources Operations, North American Rockwell Corp.-1972.
3.	B	B	Electrical Resistivity Survey in Valles Caldera, New Mexico by Group Seven, Inc. - 1972.
4.	B	B	Additional Data--Electrical Resistivity Survey in the Valles Caldera, New Mexico by Group Seven, Inc. - 1972.
5.	B	B	Reconnaissance Resistivity Survey Baca Property, McPhar - 1973.
6.	B	B	Supplemental Report--Reconnaissance Resistivity and Schlumberger Depth Sounding Surveys Baca Property - McPhar - 1973.
7.	B	B	Quantitative Gravity Interpretation Valles Caldera Area, New Mexico by R.L. Segar - 1974.
8.	B	B	Mercury Soil Gas Survey Baca Prospect by Allied Geophysics Inc. - 1974.
9.	A	A	Mercury analysis - 1974 gradient holes.
10.	B	B	Geothermal Geology of the Redondo Creek Area Baca Location by T.R. Slodowski - 1976.
11.	B	B	Magnetotelluric--Telluric Profile Survey, Valles Caldera Prospect by Geonomics - 1976.
12.	B	B	Geological Resume of the Valles Caldera by T.R. Slodowski - 1977.

FINAL REPORT

July 8, 1972

ELECTRICAL RESISTIVITY SURVEY IN THE
VALLES CALDERA, SANDOVAL COUNTY, NEW
MEXICO

Carried out by:

GROUP SEVEN, INCORPORATED
P. O. Box 374
Golden, Colorado 80401

for:

UNION OIL COMPANY OF CALIFORNIA

GROUP SEVEN

ELECTRICAL RESISTIVITY SURVEYS IN THE VALLES
CALDERA, SANDOVAL COUNTY, NEW MEXICO

ABSTRACT

Group Seven, Inc. has carried out an electrical resistivity survey of the Valles Caldera area in north-central New Mexico for the purpose of delineating potentially productive geothermal reservoirs. An area of moderately low resistivity (less than 20 ohm-meters, with conductance of 140 to 200 mhos) was recognized along the western edge of the prospect, extending outside of the prospect. This trend of low resistivity runs southwestward from Valle Seco, through Mushroom Basin to the vicinity of Horseshoe Spring. The area enclosed within this trend is 14 to 15 square miles. Two particularly interesting features are present within the main trend; an area of very low resistivity (<5 ohm-meters) north of Horseshoe Spring, and another, smaller area of very low resistivity at the mouth of Alamo Canyon. This first area of low resistivity exhibits a pattern typical of geothermal systems in other parts of the world. Depth to non-porous basement appears to be about 1.5 kilometers in the Sulfur Creek area, based on both dipole mapping data and electromagnetic sounding data.

CONTENTS

Abstract	... i
Table of Contents	...ii
Introduction	... 1
Summary of results	... 3
Evaluation	... 20
References	...109
Appendix I: Dipole mapping data	... 28
Appendix II: Electromagnetic sounding data	... 74

ELECTRICAL GEOPHYSICAL SURVEY OF THE VALLES
CALDERA AREA, SANDOVAL COUNTY, NEW MEXICO

INTRODUCTION

Group Seven, Inc. has carried out an electrical resistivity survey of the Valles Caldera area in North-Central New Mexico for the purpose of evaluating a geothermal system in terms of its potential for generating electric power. The survey was carried out on behalf of the Union Oil Company of California. Field operations were initiated on 8 May, 1972 and completed on 13 June, 1972.

The Valles Caldera prospect occupies an area some 12 miles square in Sandoval county, New Mexico, just west of the city of Los Alamos. The area is included on two U. S. Geological Survey 15-minute topographic quadrangle maps, the Jemez Springs quadrangle and the Frijoles quadrangle. The area is also covered by 7-1/2 minute topographic quadrangle maps, but the 15-minute maps were used as the base for presenting the results of the electrical survey.

The electrical survey undertaken by Group Seven, Inc. consisted primarily of direct-current dipole mapping surveys, augmented with Schlumberger direct-current soundings and electromagnetic soundings. The dipole mapping surveys were intended to locate the lateral limits of geothermal reservoirs, but such surveys provide very little information about the variation of resistivity with depth from the surface. Such information was obtained at a few locations using the Schlumberger sounding method, capable of mapping changes in resistivity at depths up to about 400 meters, and the electromagnetic sounding method, capable of detecting changes at depths ranging from 1 to 3 kilometers.

In a dipole mapping survey, a current field is developed in the earth by passing a large amount of current between two electrode contacts, separated usually by a distance of several kilometers. The behavior of the current field is then mapped in detail by measuring the voltage drop between closely spaced pairs of electrodes. The behavior of the current field is intimately related to variations in the resistivity of the ground to a depth comparable to the offset distance from the dipole source at which measurements are made. In the surveys carried out at the Valles Caldera, measurements were made at distances up to 5 or 6 kilometers, providing an adequate depth

of investigation to detect the presence of a geothermal reservoir at any depth of commercial interest. Seven dipole sources were used to provide coverage of the Valles Caldera prospect, with overlapping measurements being made in the most promising area. Over 600 measurements were made about the seven dipole sources.

Schlumberger direct-current soundings were made using a technique which has long been taken as standard (see Keller and Frischknecht, 1967, for a detailed discussion of resistivity sounding). Resistivity measurements were made with an array of four electrode contacts, spaced along a straight line. Current was provided to the ground through the outermost pair of electrodes, while voltage was measured with the inner pair. The depth to which a boundary in resistivity can be detected is roughly half the separation between the current electrodes. In making a sounding, this separation is increased incrementally to provide successively greater depths of investigation. Spacings ranging from 3 meters to 450 meters (half the current electrode separation) were used for the soundings described in this report. A total of seven soundings were made in areas of special interest, as indicated from the results of the dipole mapping surveys.

In electromagnetic sounding, the magnetic field generated by transmitting a current step through a grounded length of wire several kilometers long is used to explore the subsurface. The magnetic field is detected with an induction coil laid on the ground at a site where a sounding is to be made. The behavior of the magnetic field when a current step is transmitted through the source wire can be used to determine the electrical structure of the ground at depths up to about one half the offset distance at which measurements are being made. In the surveys described here, offset distances of 3.5 to 7 kilometers were used, providing penetrations ranging from 1-1/2 to 3-1/2 kilometers. Eighteen electromagnetic soundings were made at the Valles Caldera prospect.

The details of field techniques, data reduction procedures and the field data are included in appendices at the end of this report. The resistivity structures recognized at the Valles Caldera prospect are described in the section which follows immediately. Inferences regarding the probable existence of a geothermal reservoir capable of sustaining power production are drawn in the final section of the report.

SUMMARY OF THE RESULTS OF THE SURVEYS OF THE
VALLES CALDERA PROSPECT

Dipole mapping surveys were carried out at the Valles Caldera prospect using seven dipole sources, located as shown on Figure 1 (the base map in Figure 1 is a reduced-scale copy of portions of the Jamez Springs and Frijoles 15-minute topographic quadrangles). Contour maps of the values for apparent resistivity are given on Plates 1, 3, 5, 7 and 9, accompanying this report, while contour maps of values for apparent conductance are given on Plates 2, 4, 6, 8 and 10. It should be noted that several of these plates contain data from two dipole sources, and the contours for the two sets of data so presented are not continuous from one part of the map to the other.

Histograms showing the distributions of observed values of resistivity and conductance are given in Figures 2 and 3, respectively. The median value for somewhat more than 600 determinations of apparent resistivity is 31 ohm-meters, while the median value for conductance from the same group of measurements is 80 mhos. Considering the definition of apparent conductance, the average thickness of the surficial porous rocks in the prospect area is no greater than 2.4 km. (the product of the median resistivity and the median conductance).

The general features of the various dipole maps (Plates 1-10) that should be noted are as follows:

Dipole 1 (Sulfur Creek): The resistivity and conductance maps for this source are characterized by the presence of a swath of low resistivities, generally less than 20 ohm-meters, trending from northeast to southwest, about 4 miles in width, but centered on Sulfur Creek. Within this swath, several smaller areas with resistivity less than 5 ohm-meters are present, as on the rim north of Horseshoe Spring, southwest of Sulfur Spring, and at the mouth of Alamo Canyon. The conductance in the swath of low resistivity amounts to only 140-200 mhos, with the exceptions of the three areas just mentioned, where the conductance exceeds 400 mhos.

Dipole 2 (Southwest end of Redondo Border): These maps confirm high values for conductance, exceeding 400 mhos, and low values for apparent resistivity, less than 5 ohm-meters, for the area north of Horseshoe Springs. The area of generally low resistivity and with conductance in the range 200 to 250 mhos extends from this area eastward through Sulfur Springs to

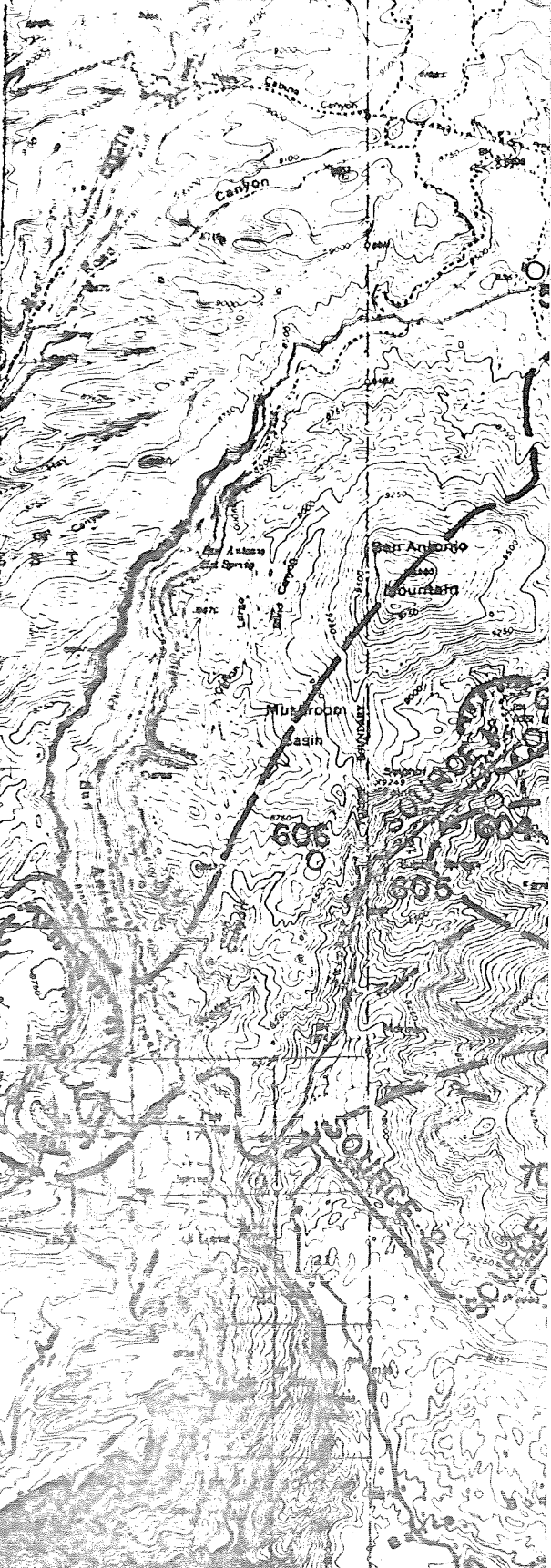

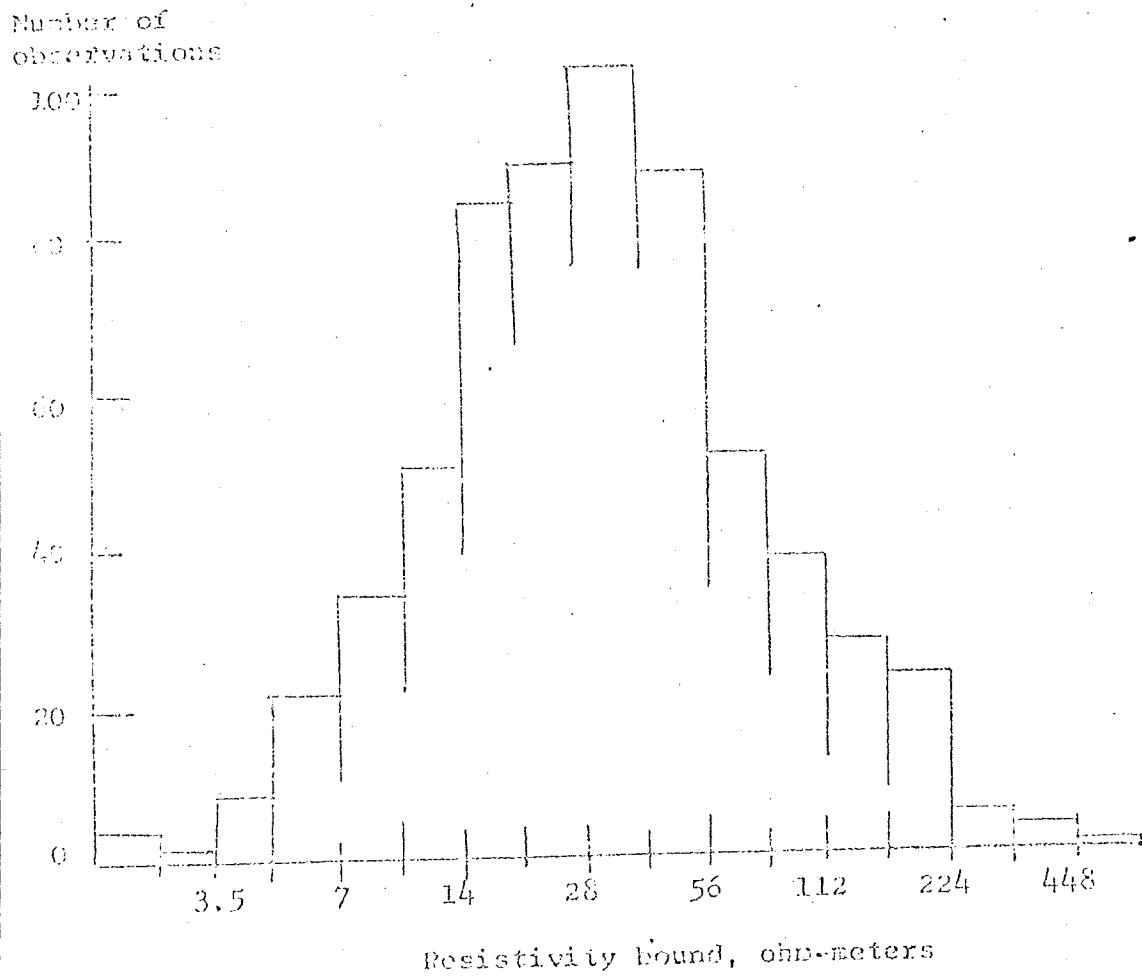

Figure 2. Histogram showing distribution of apparent resistivity values for all measurements made during dipole mapping surveys in the Valles Caldera.

Number of observations

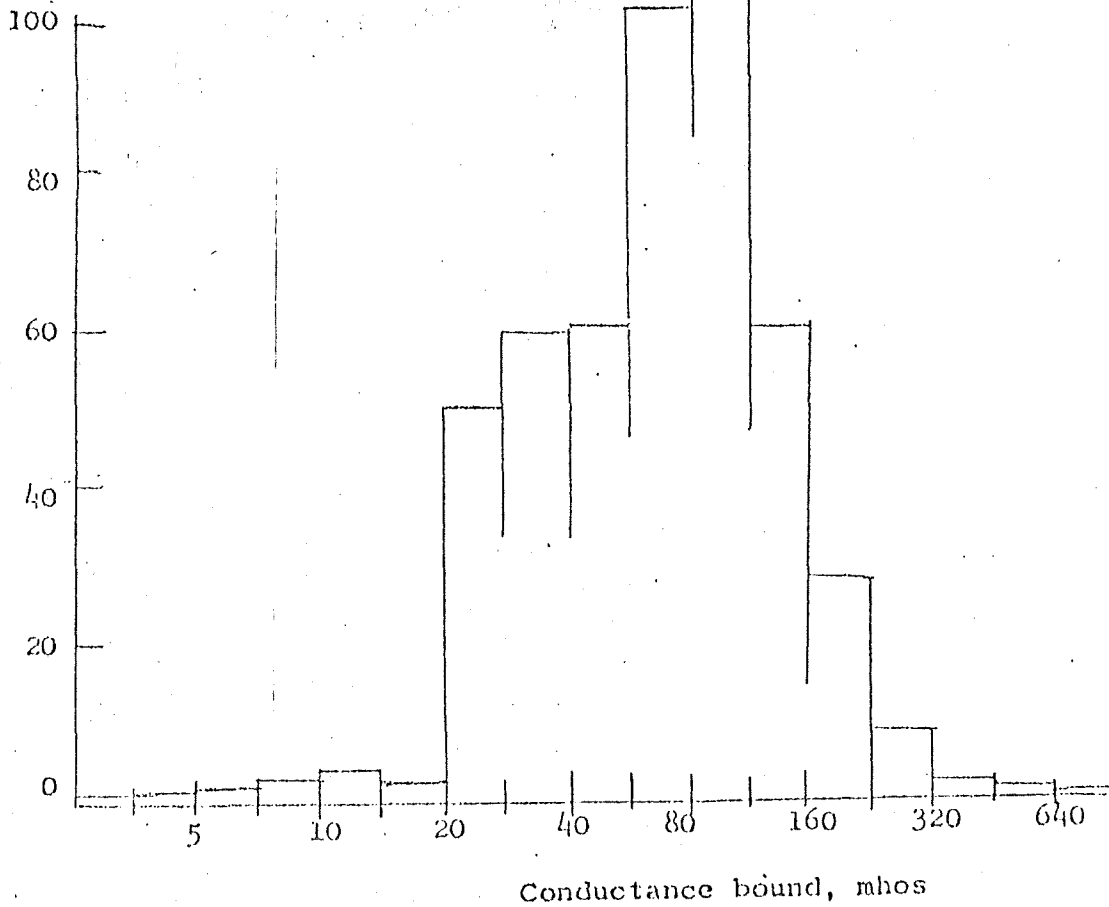

Figure 3. Histogram showing distribution of apparent conductance values for all measurements made during dipole mapping surveys in the Valles Caldera.

the west side of Redondo Peak. However, the feature becomes discontinuous as one moves east towards Redondo Peak.

Dipole 3 (Valle San Antonio): The maps about this source are characterless with the exception of a small region with resistivity less than 6 ohm-meters and conductance of 400 to 500 mhos along San Luis Creek.

Dipole 4 (Valle Grande): Measurements made from this source provided the highest resistivities (greater than 100 ohm-meters) observed in the Valles Caldera prospect. There is apparently very little porous rock in the southeast quarter of the Caldera.

Dipole 5 (Valle Santa Rosa): No sharp changes in resistivity or conductance were observed in the area mapped from this source. The resistivity is high at Cerros del Abrigo, gradually decreasing toward the north rim of the caldera. The conductance in the caldera moat, along Valle San Antonio and Valle Toledo, reaches about 200 mhos.

Source 6 (Redondo Creek): This source is characterized by the presence of an anomaly at the head of Redondo Creek with an apparent resistivity of 7 to 8 ohm-meters. A swath of moderate resistivity (<50 ohm-meters) follows Redondo Creek to the southwest. Resistivities observed along Sulfur Creek are 45 to 70 ohm-meters, considerably higher than values observed at the same locations using dipole 1. However, there is a swath of moderately high conductance (180-200 mhos) that passes through San Antonio Mountain and Mushroom Basin, generally paralleling the rim of the Caldera. The fact that about the same conductance is seen in this region using sources 1 and 6, while the resistivities differ, indicates that the low resistivity zone is relatively shallow.

Source 7 (Valle Seco). Measurements from this source provide coverage over the areas seen as having low resistivity from sources 1, 2 and 6. The results confirm the existence of low resistivities (<20 ohm-meters) and high conductance (130-180 mhos) along the Sulfur Creek - Mushroom Basin - San Antonio Mountain trend. This major trend shows a minor spur extending to the head of Redondo Creek.

These results are summarized on Figures 4 and 5, maps showing the locations of regions with low resistivity and high conductivity, respectively. In this presentation, a low resistivity is taken to be a value of 10 ohm-meters or less, and a high conductance is taken to be a value of 200 mhos or more.

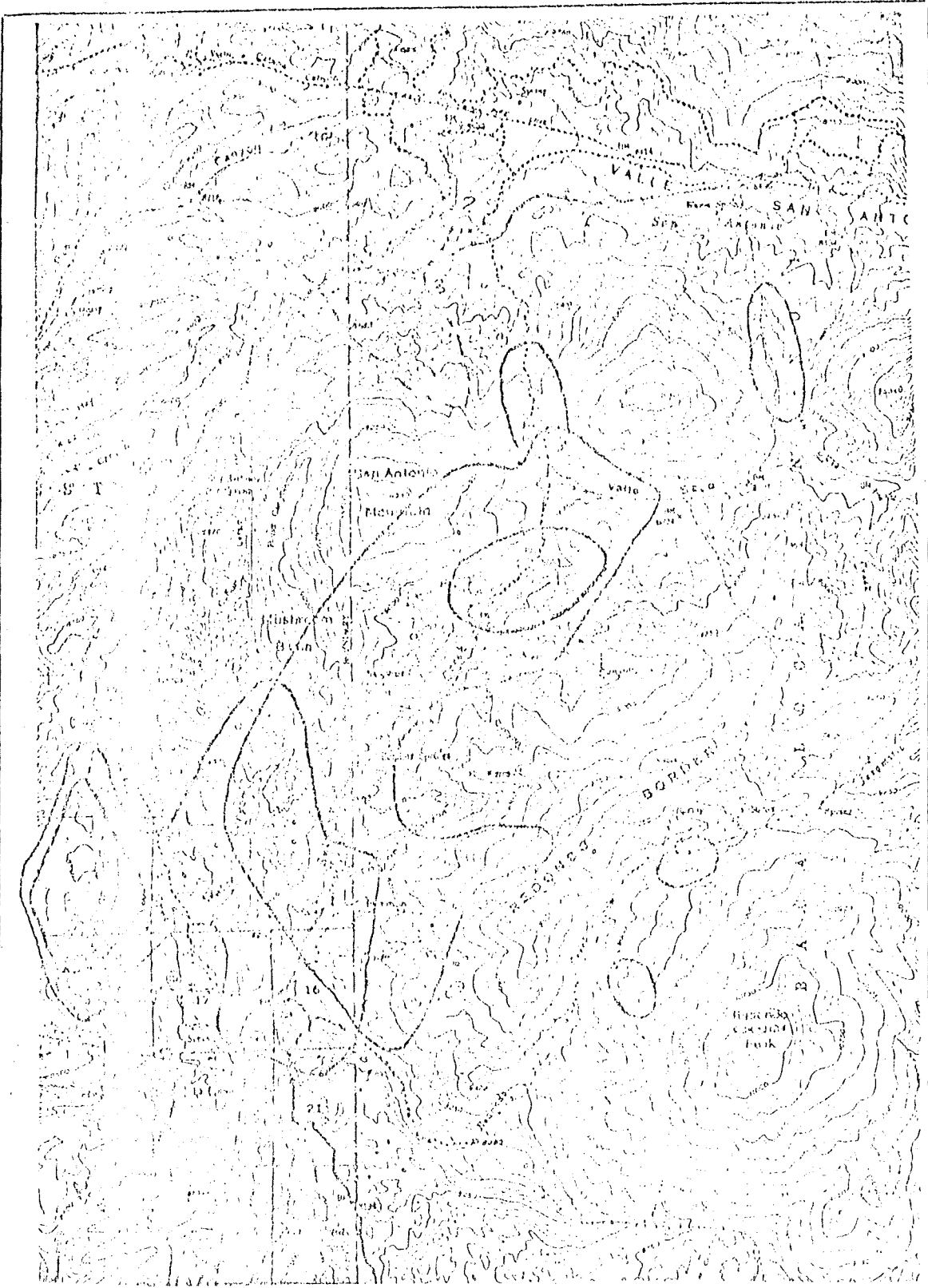

Figure 4. Apparent resistivity contours for resistivities less than 10 ohm-meters for various dipole sources in the Valles Caldera prospect.

GROUP SEVEN

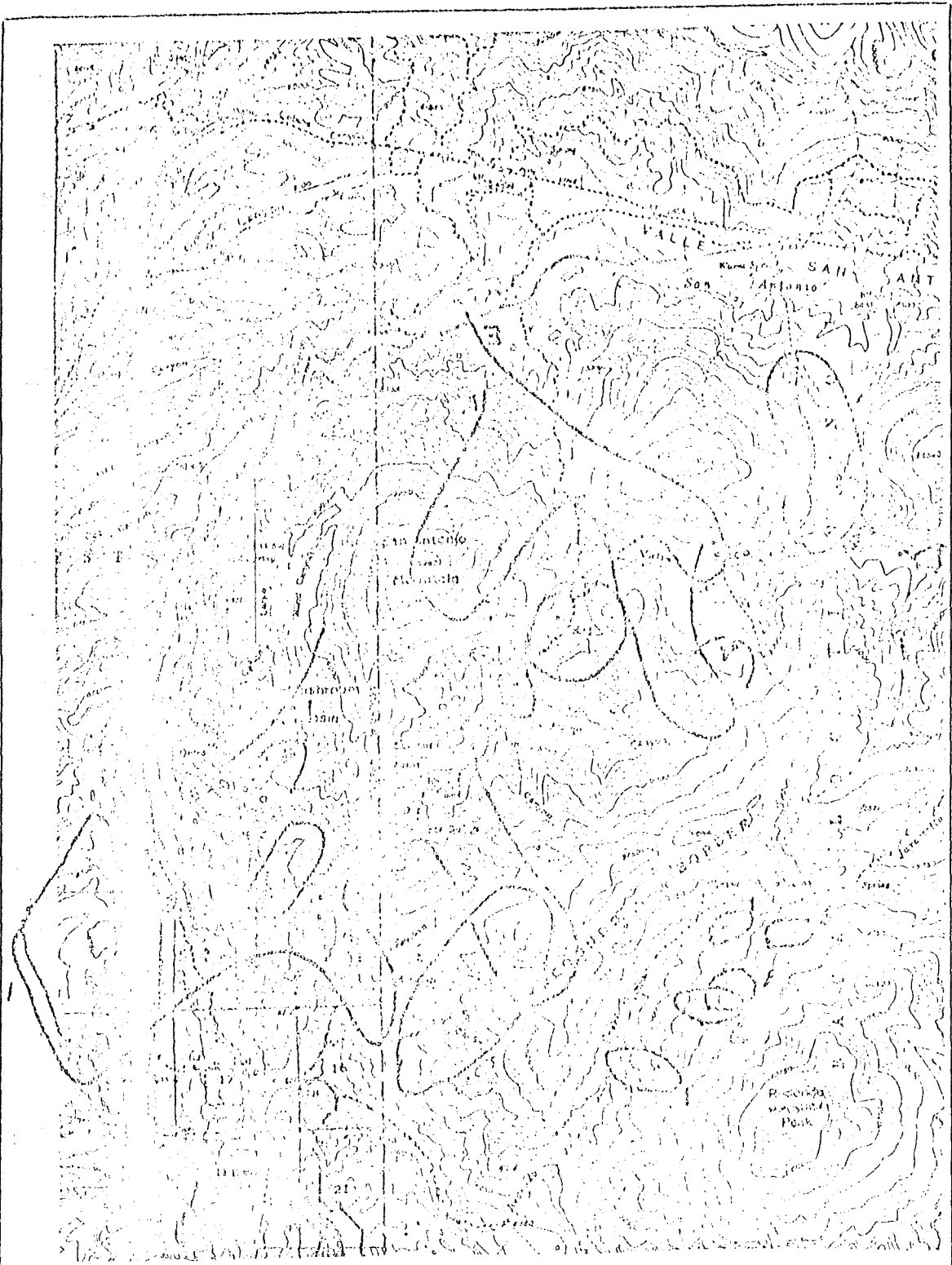

Figure 5. Western part of the Valles Caldera prospect, showing the 200-mho contours obtained with various dipole sources.

GROUP SEVEN

The results from the various dipoles do not seem to agree at first examination, but the failure to obtain similar values of apparent resistivity at a given site using several different dipole sources is to be expected in an area where the conductive surficial rocks are relatively thin. Measurements made at a considerable distance from a source will show higher resistivities than measurements made near a source because of the increased effect of high resistivity basement rocks on measurements made at the greater distance. Conversely, determinations of conductance made from measurements close to a source will provide values which are too small because current may not have an opportunity to spread to basement at close observation points. Therefore, in determining the patterns of resistivity variation in the surficial rocks, areas with low resistivity or high conductance as seen from the several dipole sources should be combined. In so doing, it is possible to outline an area of low resistivity extending southwestward from Valle Seco, through Musroon Basin to the vicinity of Horneshee Spring, as shown on Figure 1. There are several small outlying regions of low resistivity, one along San Luis Creek, and others to the west of Redondo Creek. There are two areas of especially low resistivity within this major trend, one large one in the vicinity of Boxshot Spring and another smaller one at the mouth of Alamo Canyon.

Additional information about the depth extent of these anomalous features may be derived from a study of the dipole resistivities as a function of the distance from the source at which they were measured, and from the Schlumberger and electromagnetic sounding data. If values of apparent resistivity measured from a dipole source are plotted as a function of the distance from the nearer end of the source line, they will form a sounding curve equivalent to that which might be obtained with a conventional Schlumberger array, providing that there are no lateral changes in resistivity to distort the measurements. Such equivalent sounding curves are shown in Figures 6-12 for data from each of the dipoles. In each case, the scatter of the data is extreme, indicating that lateral changes in resistivity have at least as large an effect on the measurements as do changes in resistivity with depth. Despite the scatter, the data indicate a strong tendency to increase in proportion to distance, a behavior that is characteristic of the case in which a relatively conductive surface layer rests on a highly resistant basement. If measurements are extended to spacings smaller than the depth to basement, this increase in resistivity with spacing should flatten out, with resistivity values being those appropriate to the surface layer for measurements made at short distances. Such a behavior is not obvious in Figures 6-12, but because of the scatter of the data, it would not be obvious for depths as great as 2 kilometers to basement.

Three conventional resistivity soundings with a maximum spacing of 450 meters were carried out along Sulfur Creek (see Figure 1 for locations), and four soundings were made along Redondo Creek. These two sets of soundings are shown on Figures 5A and 5B respectively. They all have a very similar character, and provide essentially the same interpretation when evaluated with a standard curve-matching procedure. For the soundings made along Sulfur Creek, the shape of the curves is dominated by a thin surface layer of high resistivity, with a thickness of only 8-15 meters, and a resistivity of 200 to 300 ohm-meters. This layer is underlain by rocks with progressively lower resistivities, until a resistivity of 12 to 13 ohm-meters is reached at a depth for 400 to 450 meters. At location 8, the resistivity at depth is especially low, decreasing to only 4 ohm-meters at 230 meters depth, but then begins to increase at greater depths.

Along Redondo Creek, the thin surface layer is only about 8 meters thick, but has a resistivity of 150-400 ohm-meters. The resistivity then decreases to a value of 8 to 12 ohm-meters at depths of 150 to 180 meters, increasing again at greater depths.

In areas such as the Valles Caldera where lateral resistivity changes are marked, it is not possible to expand a Schlumberger array to the large spacings required to detect basement, and yet meet the requirements for lateral uniformity imposed by interpretation procedures. However, electromagnetic soundings provide a partial solution to the problem of obtaining information from greater depths. Electromagnetic soundings cannot be interpreted with as much resolution as Schlumberger soundings, but are far less affected by lateral changes in resistivity. The interpretation of electromagnetic soundings is discussed in Appendix II.

Eighteen electromagnetic soundings were made as part of the Valles Caldera electrical survey, and the data and reduced curves are also included in Appendix II. These soundings were made primarily in Sulfur Creek Valley and Redondo Creek Valley, as indicated on the map in Figure 1. The interpretations provided an average resistivity for the conductive surface rocks and a depth to resistant basement, as listed in the following Table:

Table. Electromagnetic interpretations

Sounding number	Surface resistivity	Depth to basement
501	27 ohm-m	3500 meters
502	19	2500
503	40	2100
506	16	2800

Apparent resistivity,
ohm-meters

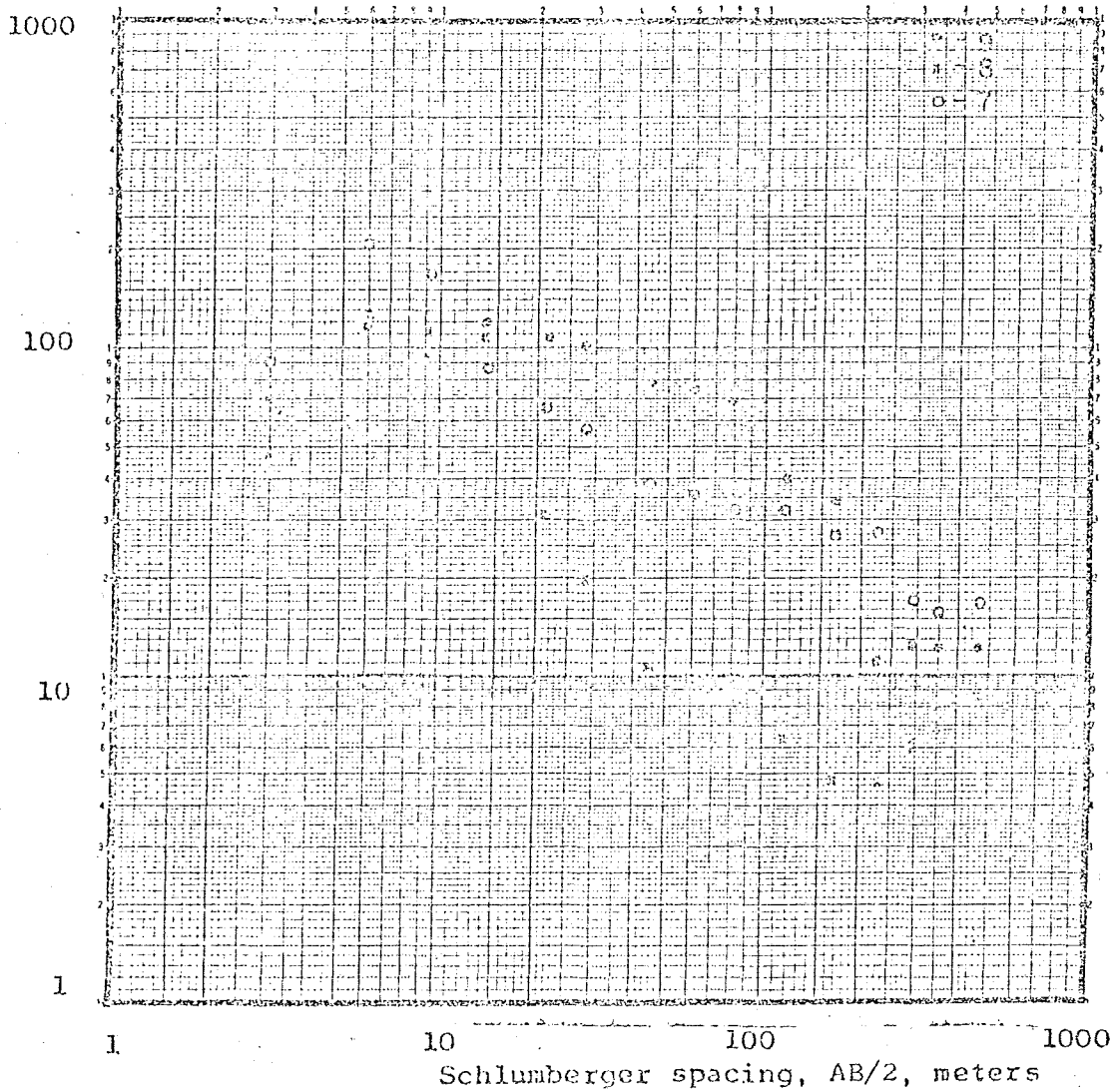

Figure 5A. Three Schlumberger resistivity soundings run along Sulfur Creek between Sulfur Springs and Alamo Canyon

GROUP SEVEN

Apparent resistivity
ohm-meters

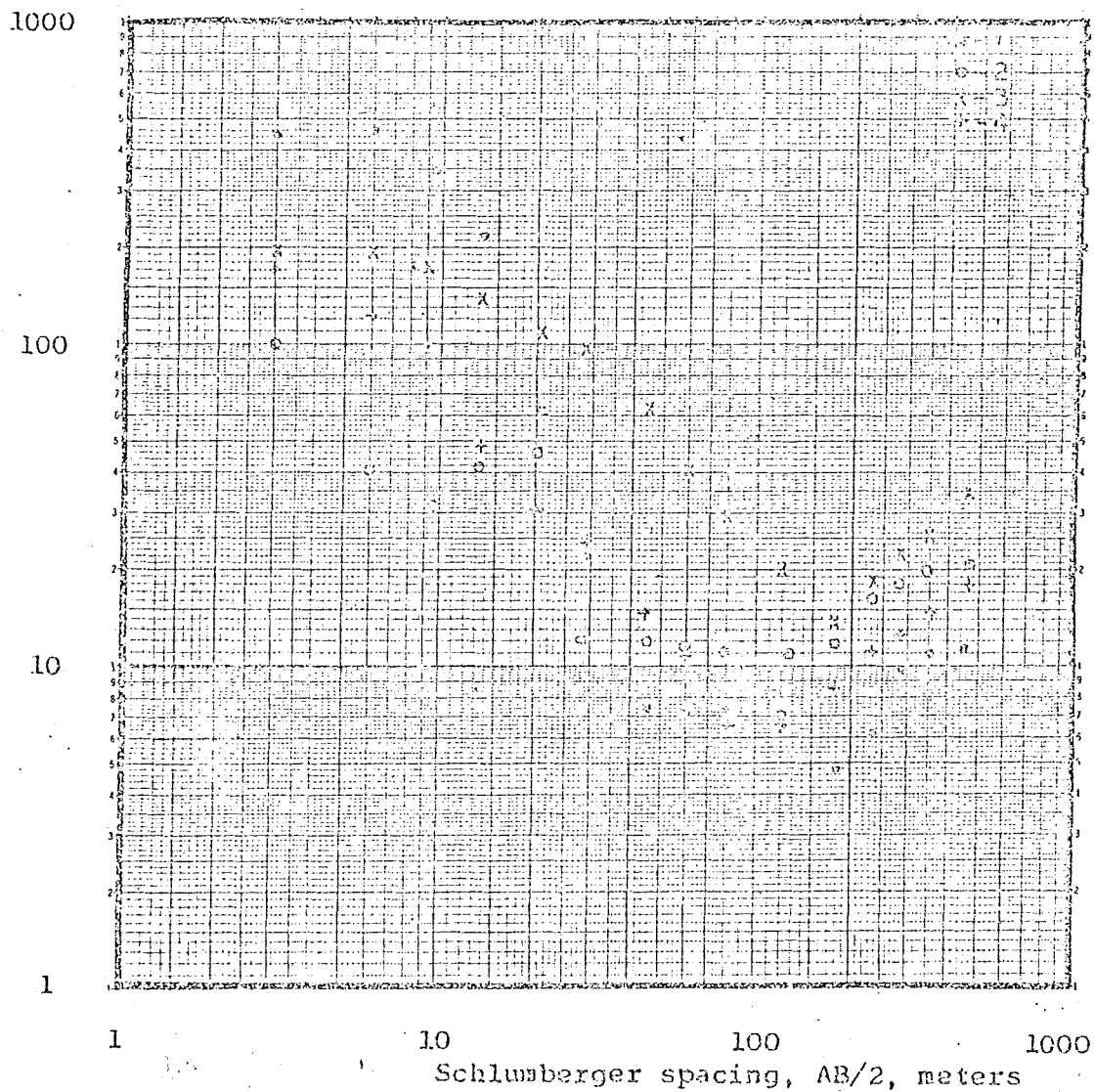

Figure 5B. Four Schlumberger resistivity soundings run along Redondo Creek.

Apparent resistivity, ohm-m.

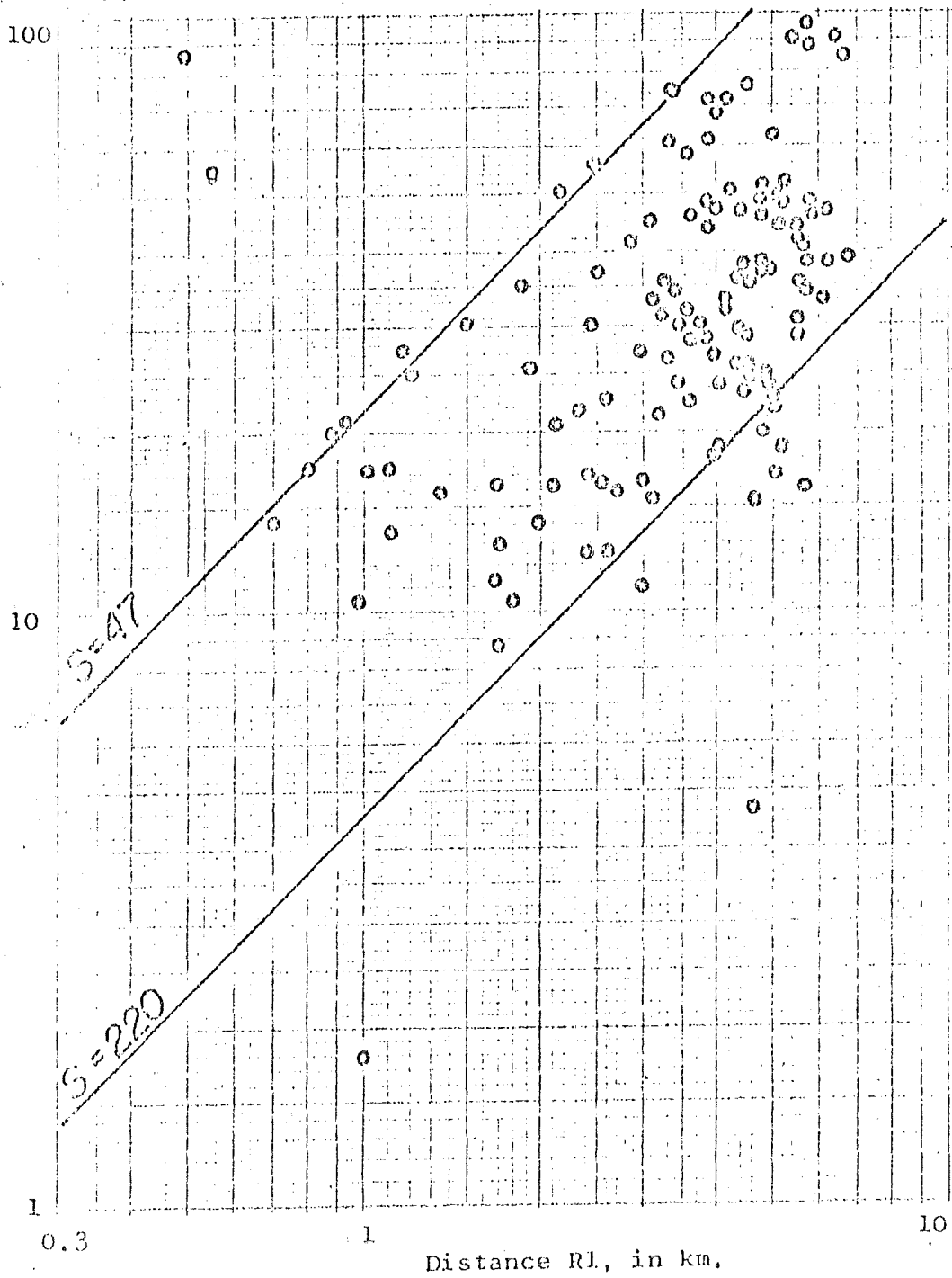

Figure 6. Apparent resistivities measured about source 7 plotted as a function of the distance to the nearer end of the source dipole.

GROUP SEVEN

Apparent resistivity, ohm-m
1000

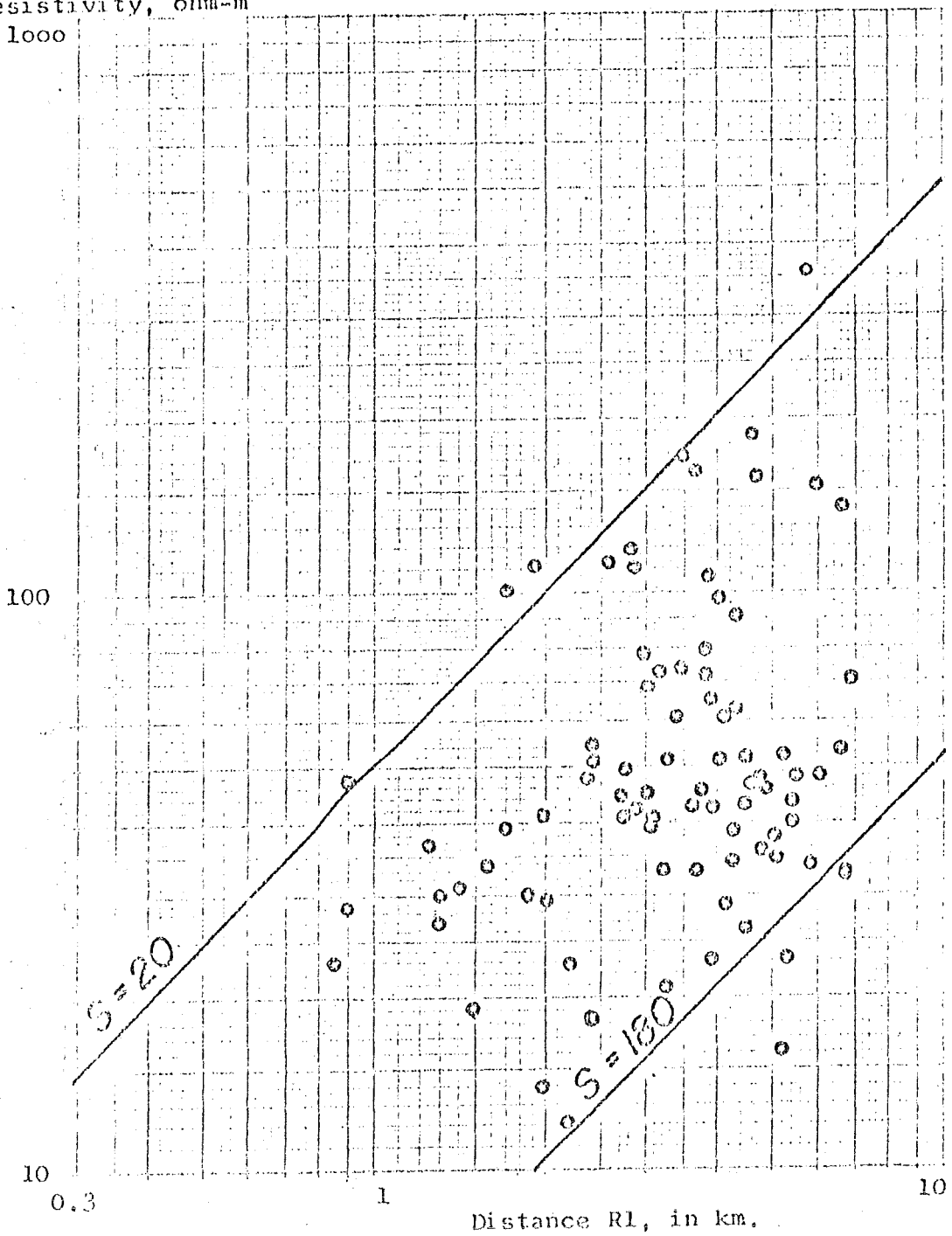

Figure 7 . Apparent resistivities measured about source 6 plotted as a function of the distance to the nearer end of the source dipole.

GROUP SEVEN

Apparent Resistivity,
ohm-meters

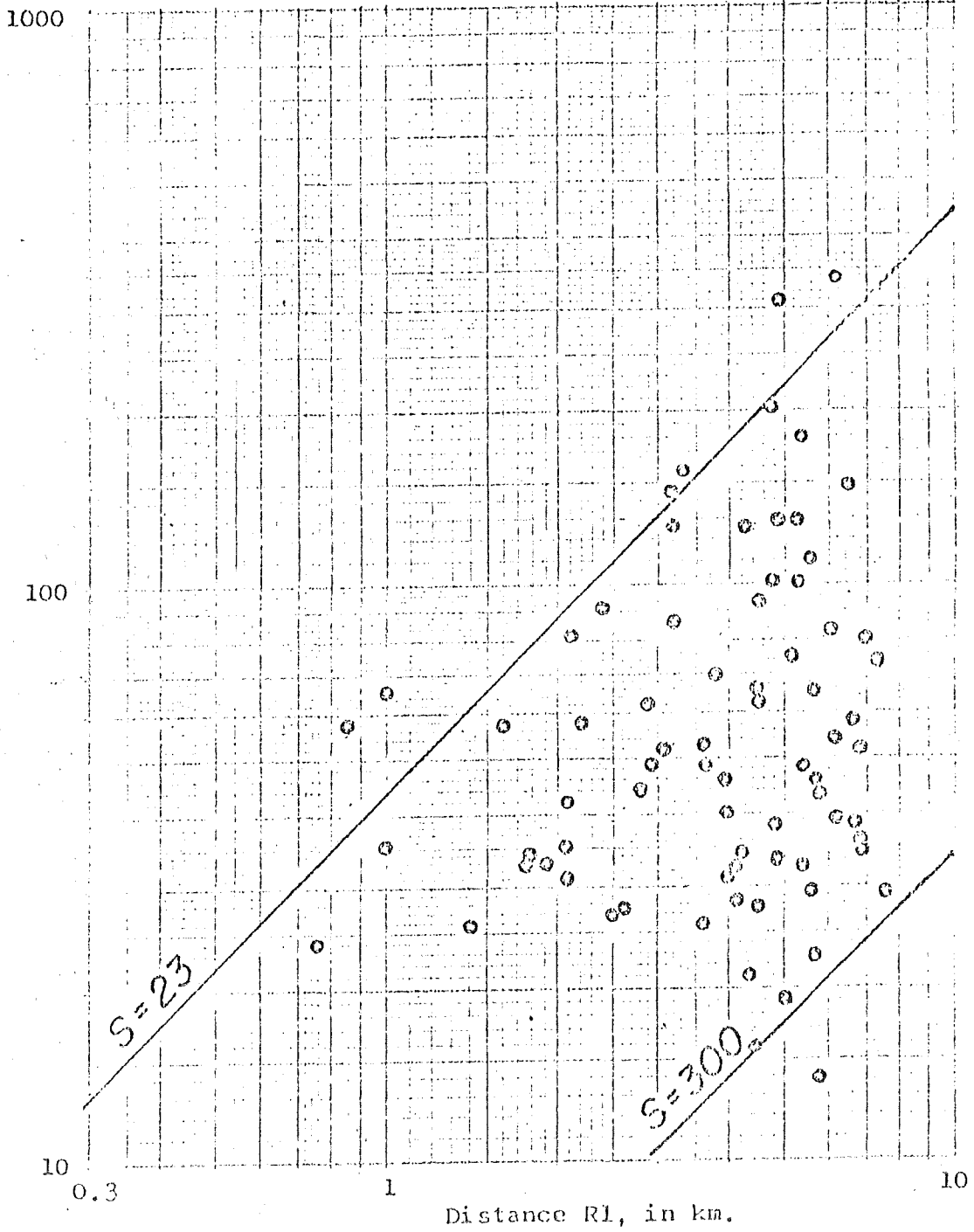

Figure 8. Apparent resistivities measured about source 5 plotted as a function of the distance to the nearer end of the source dipole.

GROUP SEVEN

Apparent resistivity, ohm-m

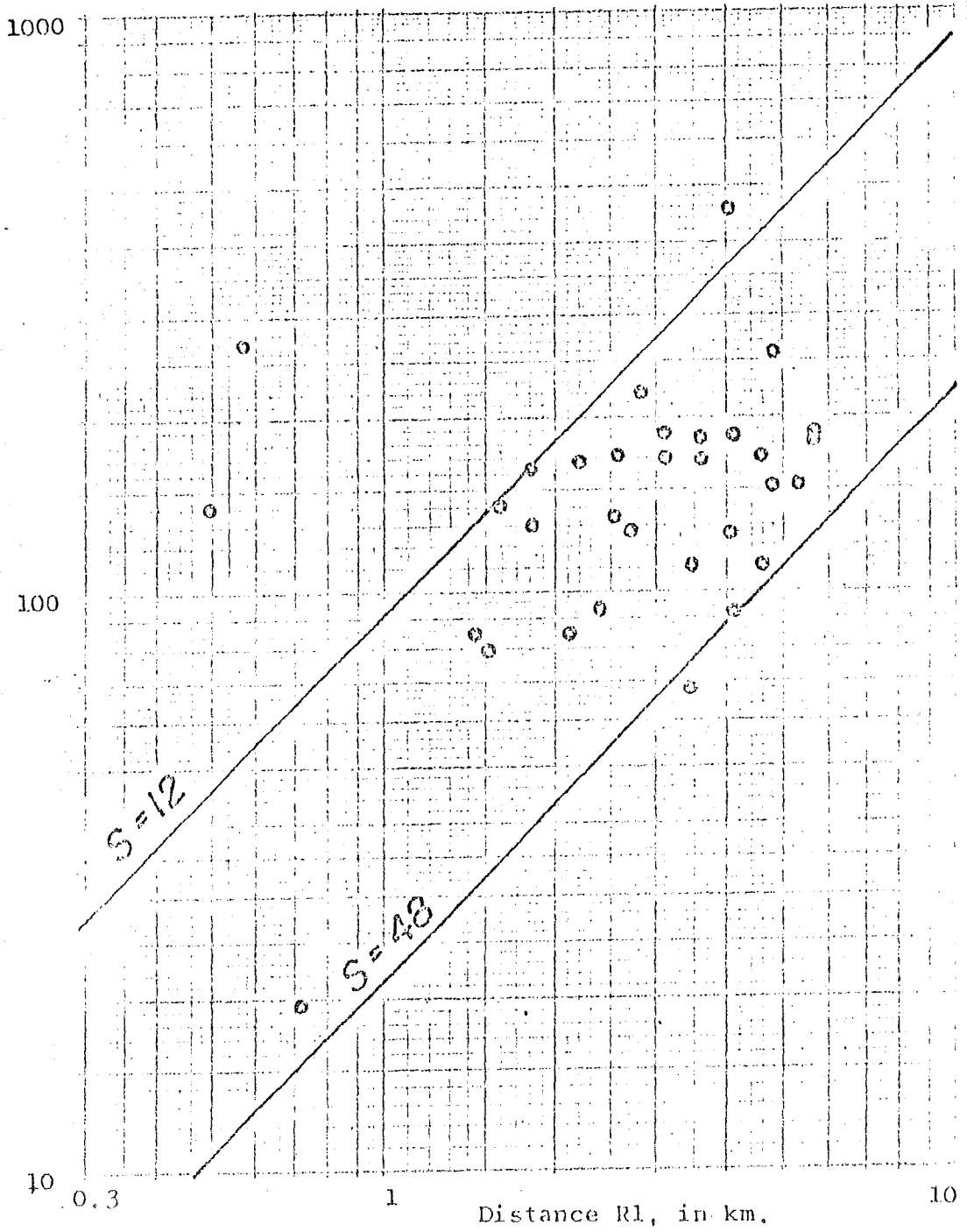

Figure 9 . Apparent resistivities measured about source 4 plotted as a function of the distance to the nearer end of the source dipole.

GROUP SEVEN

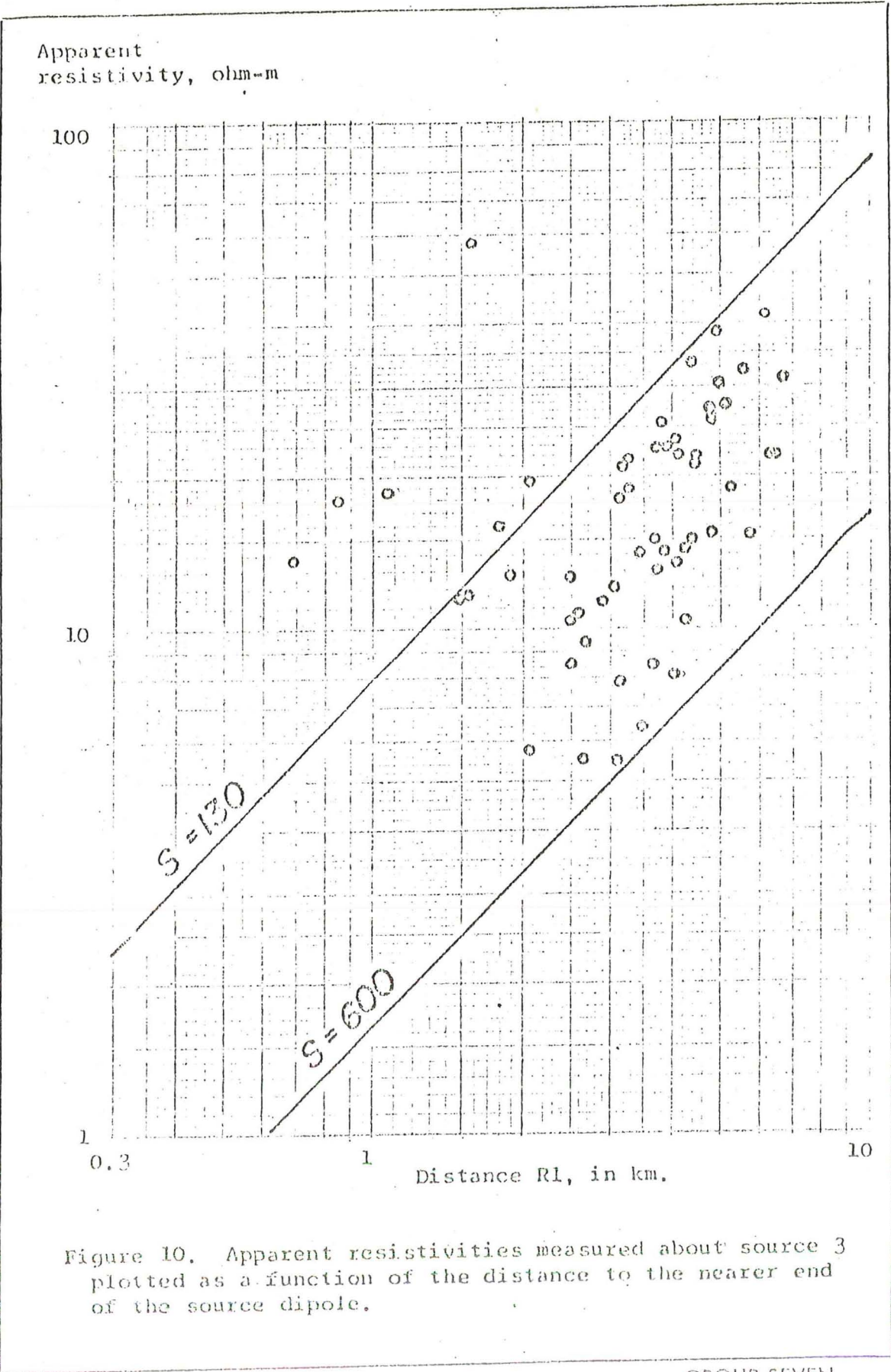

Figure 10. Apparent resistivities measured about source 3 plotted as a function of the distance to the nearer end of the source dipole.

GROUP SEVEN

Apparent resistivity, ohm-m

100

10

1

0.3

1

10

Distance R_1 , in km.

$S=70$

$S=600$

Figure 11. Apparent resistivities measured about source 2, plotted as a function of the distance to the nearer end of the source dipole

GROUP SEVEN

Apparent resistivity, ohm-m

100

10

1

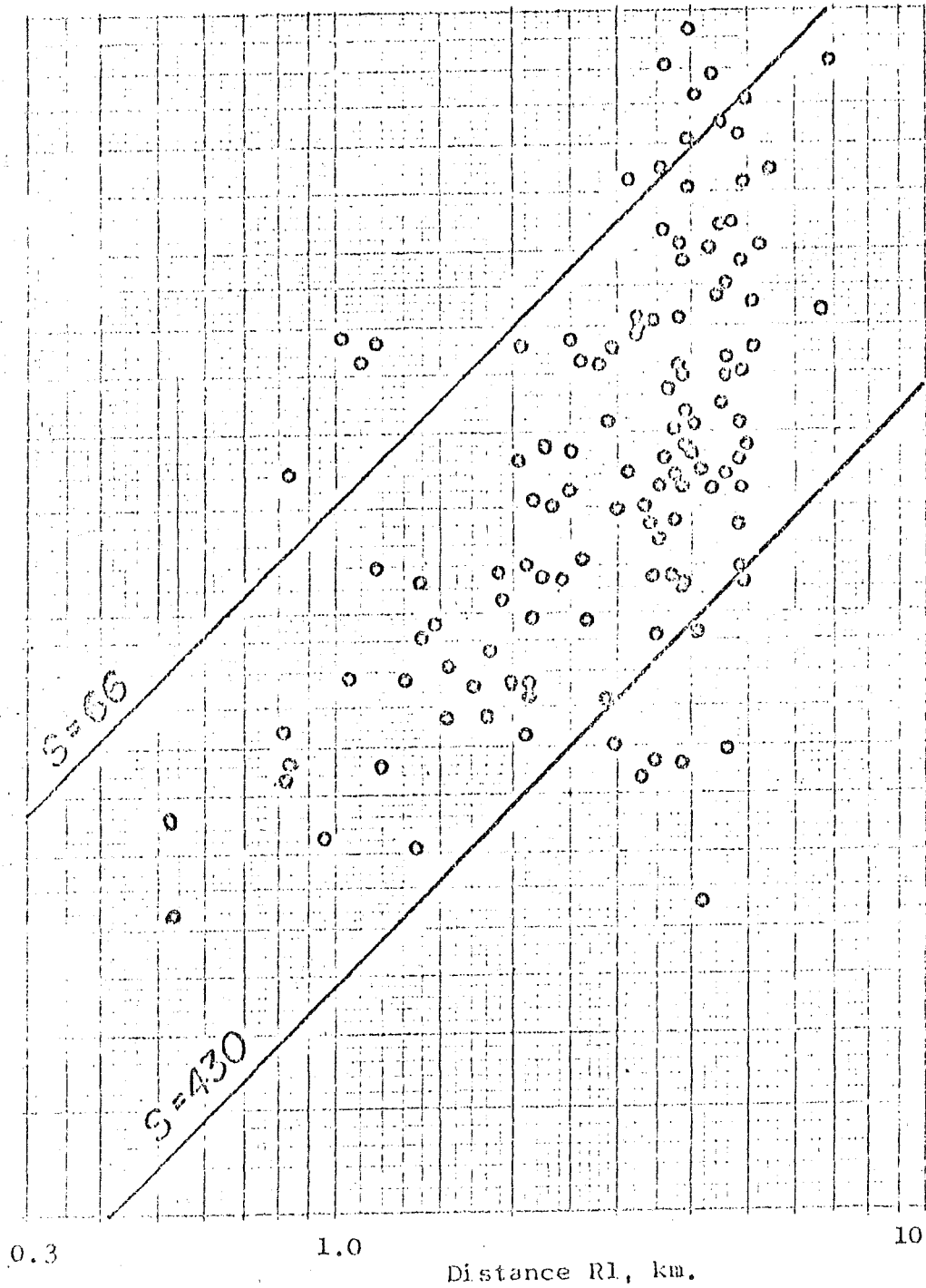

Figure 12. Apparent resistivities measured about source 1, plotted as a function of the distance to the nearer end of the source dipole.

GROUP SEVEN

507	12.5 ohm-m	2400 meters
508	18	3200
601	13	1350
602	12.5	1770
603	20	1020
604	19	1170
605	18	1400
606	3.8	820
701	19	>2000
702	21	>2300
705	22	1800
706	17	1850
707	19	1950
708	10	2500

It should be noted that even with high-quality data, electromagnetic sounding curves for the case of a buried resistor provide a resolution in depth determination of no better than ± 20 percent. Considering this, the electromagnetic soundings indicate that the porous surficial rocks have a resistivity generally between 10 and 20 ohm-meters in the Redondo and Sulfur Creek areas, with the depth to basement being approximately 1400 meters in the Sulfur Creek area and approximately 2000 meters in the Redondo Creek area. Along the northern moat, in the Valle San Antonio area, the resistivity is somewhat higher, being generally 20 ohm-meters or more, and the depth to basement is greater, being approximately 2500 to 3000 meters. This greater depth to basement in the Valle San Antonio explains the moderately high values of conductance observed along the northern rim of the Caldera on several of the dipole maps.

Considering all these data, it appears that the swath of ground with low resistivity paralleling Sulfur Creek has an average resistivity of 10 to 15 ohm-meters to a depth of 1400 meters on the average. The strong anomaly north of Horseshoe Springs probably represents rocks with a comparable thickness, but with a resistivity reduced to 3 to 4 ohm-meters. This pattern of resistivity -- a sharply bounded region with resistivity of 3 to 10 ohm-meters -- is typical of geothermal systems in other parts of the world. The total conductance observed in the anomalous areas is considerably lower than that in most geothermal fields. Typically, conductance reaches values of 1000 to 2000 mhos at places such as Wairaki. The low values in the Valles Caldera probably result from the combined effect of a relatively thin section of porous rock, and a porosity that is somewhat lower on the average than in most geothermal fields found in volcanic rocks.

EVALUATION OF RESULTS

In addition to using the resistivity data described in the preceding section in delineating the boundaries of conductive areas associated with the occurrence of hot water in the subsurface, these data may sometimes also be used to infer other characteristics of thermal areas. It is well known that the resistivity of a porous rock is determined almost entirely by the amount of water contained in the rock and the resistivity of that water. The resistivity of water is in turn determined by salinity and temperature. The variation in resistivity of a volcanic rock as a function of water content should be similar to that shown in Figure 13, taken from a compilation of data for volcanic rocks from the southwestern United States (Keller, 1960). The amount of water-filled porosity in a volcanic rock may be estimated from its resistivity, if the resistivity of the water contained in the pore space is known.

The porous rocks in the Valles Caldera appear to be saturated with low-salinity surface waters, which is reasonable considering the elevation of the Caldera and the age of the volcanic rocks comprising the porous section. Unfortunately, when a rock is saturated with water having a salinity of less than a few thousand parts per million dissolved solids, the conductivity of the water in the pore structures is determined more by cation exchange effects and surface conduction than by free salinity. Therefore, determinations of salinity on water samples taken from springs or drill holes are of little use in estimating the effective resistivity of the water in place in a rock. The degree to which water conductivity is affected by ion exchange and surface conductance depends on the clay content of a rock and on the grain size distribution. However, for fresh-water saturated rocks in the southwest, it has been observed that water in place at room temperature has a resistivity of approximately 1.5 ohm-meters. For lack of better information, this value might be used also for volcanic rocks at the Valles Caldera (Keller, 1962).

In order to estimate porosity, we need to select representative values of resistivity from the field data. Considering the histograms in Figures 2 and 3 along with the various sounding data, we might select the following resistivities as representing the surficial rocks in various parts of the Valles Caldera:

- | | |
|---|----------------------|
| 1. Valle Grande (area showing least thermal effects): | 80 to 100 ohm-meters |
| 2. Northern moat (Valle San Antonio) | 20 to 40 ohm-meters |
| 3. Sulfur Creek trend | 12 to 15 ohm-meters |

Volume fraction of water
present in pore space.

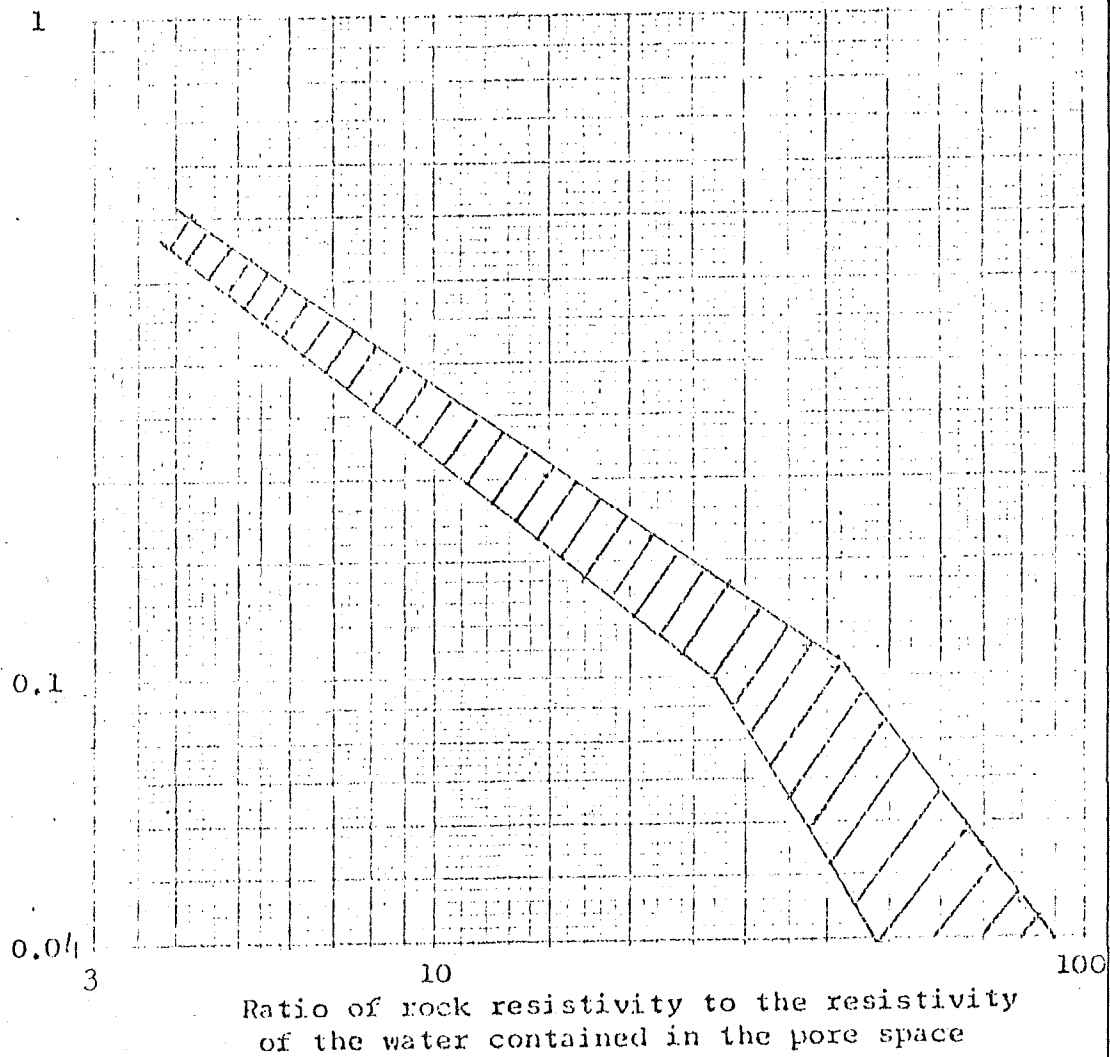

Figure 13. Empirical relationship between rock resistivity and water content for pyroclastic rocks.

4. Horseshoe Springs and Alamo Canyon anomalies

3-5 ohm-meters

The variation in resistivity from one area to another may be a consequence of a change in porosity from one area to another, a change in temperature which alters the resistivity of the pore water, or possibly a change in water salinity. No information is available from the electrical surveys to indicate which factor is the actual cause, and indeed, the variations may be the result of changes in each parameter simultaneously. However, we can estimate what the maximum change in any one parameter might be from area to area by assuming the change in resistivity is caused only by a change in that parameter. Such maximum changes would be as follows, if the changes were due only to variations in average porosity of the porous interval:

Area	Porosity for water resistivity of 1.5 ohm-meters at surface temperatures
Valle Grande	.04 - .05
Valle San Antonio	.13 - .17
Sulfur Creek Trend	.24 - .30
Horseshoe Springs	about .6

These values are subject to errors made in assuming the proper water resistivity. More reliable estimates could be made by combining the resistivity information with seismic velocity determinations (for an independent estimate of porosity) or gravity data (for an estimate of rock density).

The variation of electrical resistivity with temperature in dilute solutions of ionic electrolytes has been studied by Quist and Marshall (1966, 1968), and on the basis of their data, a correction chart for the effect of temperature on the resistivity of water can be prepared (Figure 14). At pressures and temperatures below the critical point for water (374.4° C and 218 bars), the resistivity of water decreases with increasing temperature until the boiling point is reached; above the boiling point, the resistivity is effectively infinite. Near the critical point, the behavior is somewhat different: the resistivity still decreases with increasing temperature, but then, rather than increasing abruptly at the boiling point, the resistivity passes gradually through a minimum value and at higher temperatures, increases gradually. As the boiling point is raised by increasing the ambient pressure, the enhancement in electrical conductivity becomes more pronounced, amounting to a factor of 7 by the time the critical pressure and temper-

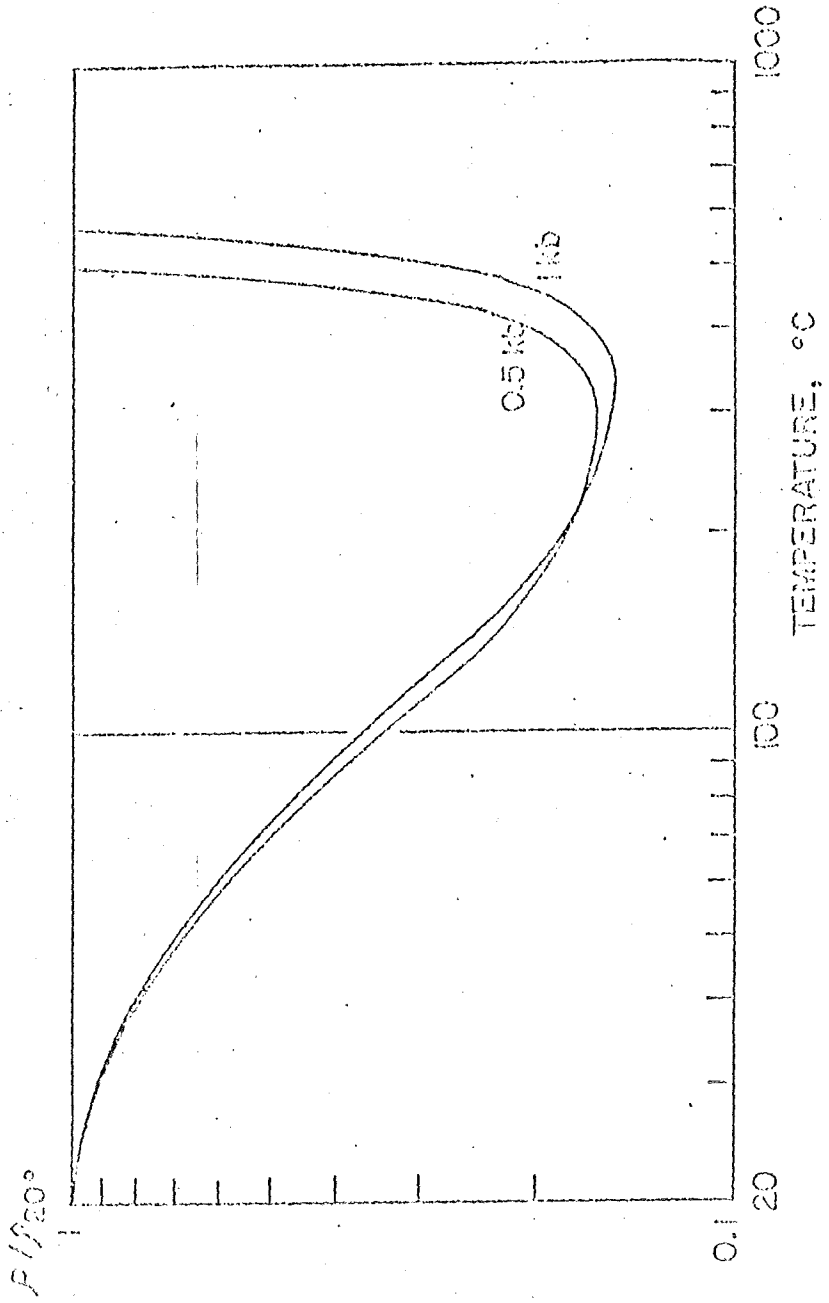

Figure 14 Variation in the resistivity of a dilute solution of sodium chloride with temperature and pressure.

ature are reached. In volcanic rocks, pressure increases with depth at a rate of at least .030 bars per meter of burial, if pressure is simply hydrostatic. For reservoir depths of 1 kilometer, we would expect resistivities to be lower by a factor of 4 to 5 for rocks heated to just below the boiling point, while the resistivity would be very great if the temperature were greater than the boiling point. At depths beyond 3 kilometers, temperatures high enough to cause high resistivity cannot occur, and so, in deep reservoirs, there should always be an anomalously low resistivity.

If the temperature is exactly at the boiling point, steam and water can exist simultaneously in the rock. In such a case, the enhancement in conductivity is less and might not provide a reasonable target for electrical exploration. However, a reservoir in which a large fraction of the pore fluid is steam would not provide much capacity for power production because of the low enthalpy per unit volume of steam in comparison with that of boiling water (see Figure 15). The enthalpy of boiling water passes through a maximum at about 320° C. At the same temperature, the enthalpy per unit volume of steam is only 10 percent that of water. At somewhat lower temperatures, the enthalpy of steam drops to less than 1 percent that of boiling water. Therefore, a geothermal reservoir with a high energy content will always be wet and exhibit an anomalously low resistivity.

Considering now that the changes in resistivity from area to area are a consequence only of changes in temperature, and that porosity remains fixed, using the curves from Figure 14, we arrive at the following temperatures for the four areas:

Valle Grande	20° assumed
Valle San Antonio	130°
Sulfur Creek Trend	220°
Horseshoe Springs	Not explainable in terms of temperature alone.

It is apparent here that the extremes in resistivity are too large to be explained only by temperature effects, and an increase in porosity must also be observed in the areas of particularly low resistivity. An increase in porosity may be traded off against an increase in temperature in explaining the change in resistivity from area to area as shown by the curves in Figure 16. From these curves, it is apparent that a relatively minor change in porosity will degrade the temperature differences to a greater extent than is compatible with temperatures already observed in drill holes in the Sulfur Creek area. The most reasonable explanation at this stage is

Enthalpy in
calories per 1000 cc
1000

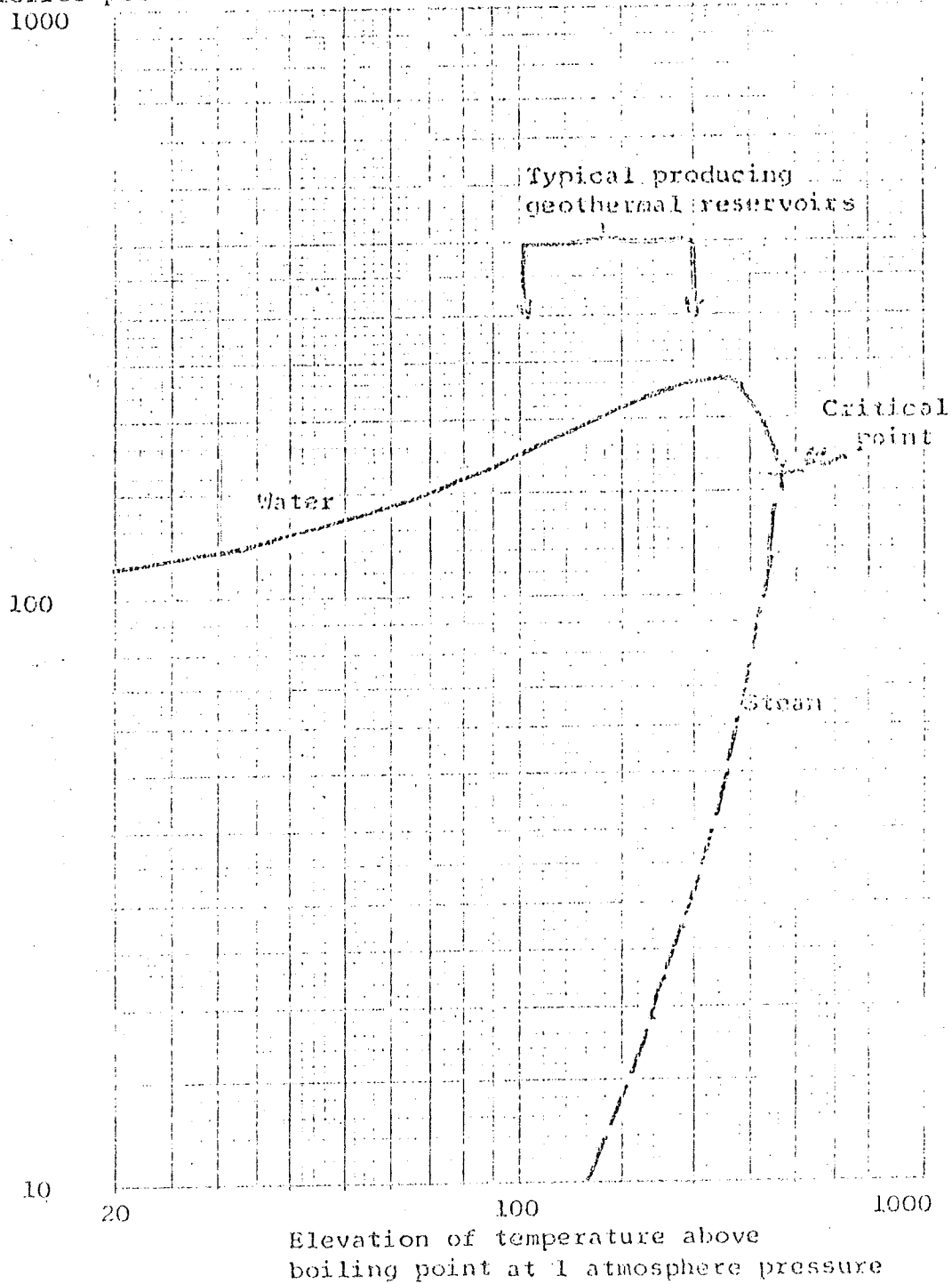

Figure 15. Enthalpy per unit volume of boiling water and of steam at the boiling point.

Ratio of resistivity to that
at Valle Grande

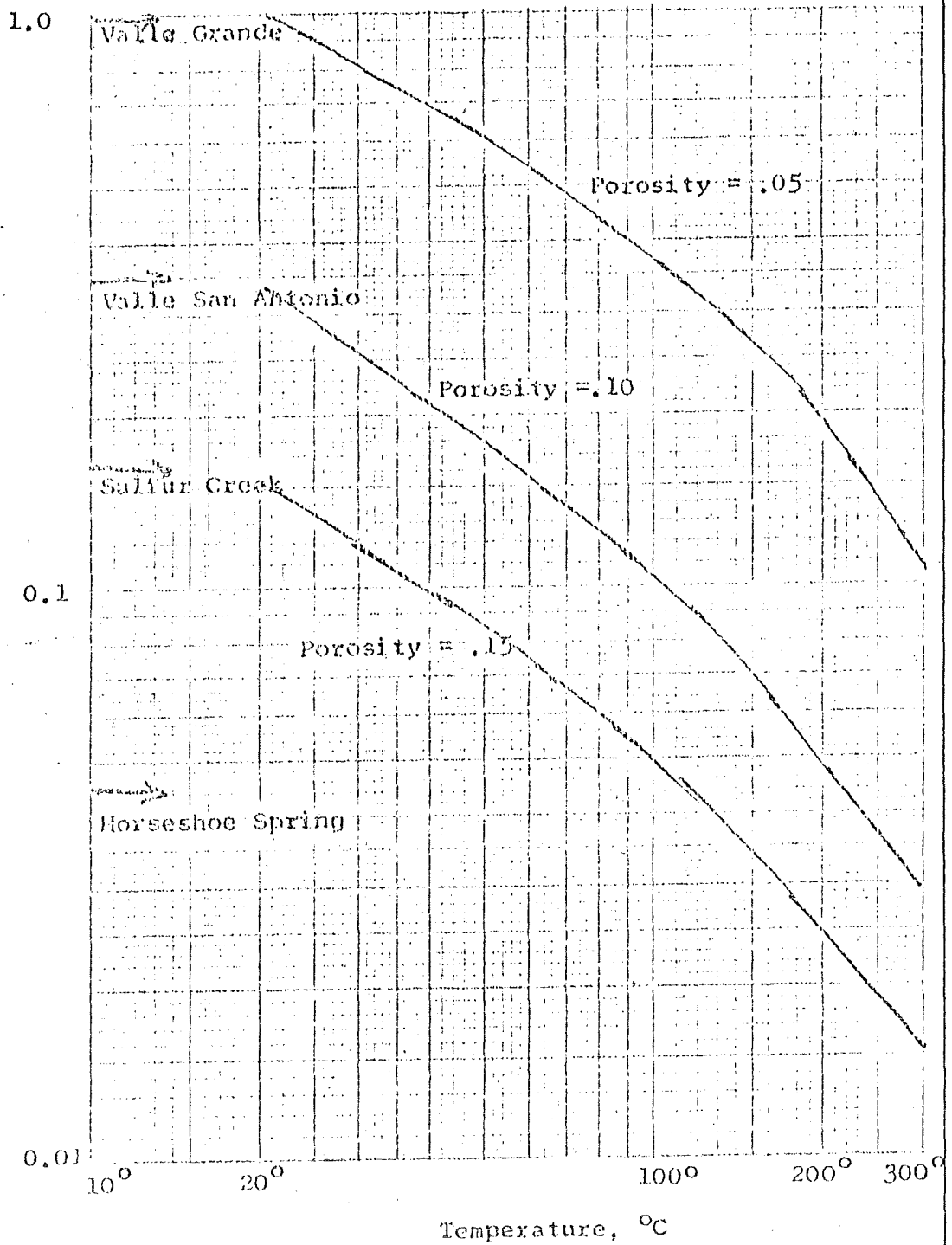

Figure 16. Effect of changing porosity on the temperature differences interpreted from resistivity values observed in various parts of the Valles Caldera.

GROUP SEVEN

porosities are generally low in the Valle San Antonio and Sulfur Creek areas, perhaps only 10 to 12 percent, but are locally higher at Horseshoe Springs and at the mouth of Alamo Canyon.

These speculations may be used to estimate the maximum amount of energy available from the thermal areas mapped at the Valles Caldera. The area of the anomalies at Horseshoe Spring and Alamo Canyon is approximately 4-1/2 square kilometers. The thickness of the conductive sequence is about 1-1.2 kilometers, giving a reservoir volume of 6.75 cubic kilometers. Assuming an average porosity of 25 percent gives a volume of 1.68 cubic kilometers for the hot water in the reservoir. According to the curves in Figure 15, the maximum energy content for this water would be slightly more than 200 calories per 1000 cc, or in terms of the electrical equivalent, 2.66×10^{10} Megawatt-years per 1000 cc. For the entire reservoir volume, this means there would be a maximum of

4.5×10^3 Megawatt-years of energy

represented by the enthalpy. It has been estimated that from 2 to 20 percent of the energy in a reservoir can be converted to electrical energy, so the maximum recoverable energy in the low-resistivity anomalous areas of the Valles Caldera would be

90 to 900 Megawatt years.

In addition to the energy available from these two small areas, one might also consider the energy available from the Sulfur Creek trend of low resistivity rocks. This trend has a much larger area, amounting to about 30 square kilometers, or assuming a reservoir thickness of 1-1/5 kilometers, a volume of 45 cubic kilometers. With a porosity of 12.5 percent, the volume of water present would be 5.62 cubic kilometers. The enthalpy of this water would be at its maximum

82×10^3 Megawatt-years

or assuming the same efficiencies for energy conversion, the convertible electrical energy would be

164 to 1640 Megawatt years

With a low-porosity reservoir, some difficulty in locating permeable zones for production may be met. On the other hand, because production would be largely through fracture channels, it is likely the reservoir would act as a "dry steam" reservoir. It should also be pointed out that the energy calculated here is only the energy in the fluid content of the rock. In a low porosity rock, an equal amount of energy, or even more, may be stored as heat in the solid phases.

APPENDIX I: DIPOLE MAPPING SURVEYS

In a dipole mapping survey, as the expression is used here, a large amount of electric current is caused to flow in the earth between electrode contacts sited in the general vicinity of the target area. As the current flows through the ground from this dipole source, the flow pattern will be governed in detail by variations in resistivity in the ground to a depth comparable to the offset distance at which the measurements are being made. Because the dipole source is fixed in location while many measurements of electric field are made about it, any electrical non-uniformities near the source will affect all the measurements similarly, and the variation in the characteristics of the electric field from observation point to observation point will be indicative of the electrical structure of the ground primarily in the vicinity of the measurement sites.

The general scheme of a dipole mapping survey is indicated on Figure 17. For the surveys carried out on the Valles Caldera prospect, dipole lengths of 1.5 to 2.5 kilometers were used. In most cases, the dipoles were grounded at metal road culverts. In one or two cases, grounding was obtained through contact with well casings. Power was taken from a 10-KVA motor generator set. The 220-volt single-phase 60 Hz output of the generator was stepped up to 660 or 880 volts with a transformer, rectified to form direct current and alternately switched to cause current to flow first one way and then the other in the cable connecting the power supply to the electrode contacts. The period of reversal of the current flow was selected to be 28 seconds, so that the frequencies contained in the waveform of the current would be sufficiently low to avoid problems with electromagnetic attenuation of the current field and lack of penetration caused by skin-depth effects. The current waveform was asymmetrical, with the duration of current flow in one direction being about 40 percent greater than the duration in the other; this provided a means for assigning a polarity to the voltage detected at the receiving sites. The amplitude of the current steps was recorded with an analog recorder and monitored visually with an indicating meter. Usually, current steps with amplitudes ranging from 10 to 20 amperes were used.

The current field from a source dipole was mapped by measuring voltages between electrode pairs at many points about the source dipole. Because the direction of current flow at a measurement point is quite unpredictable, the total voltage drop must be determined by making measurements with two electrode pairs oriented at right angles to one another and adding these voltages vectorially. The electric field is then assumed to be

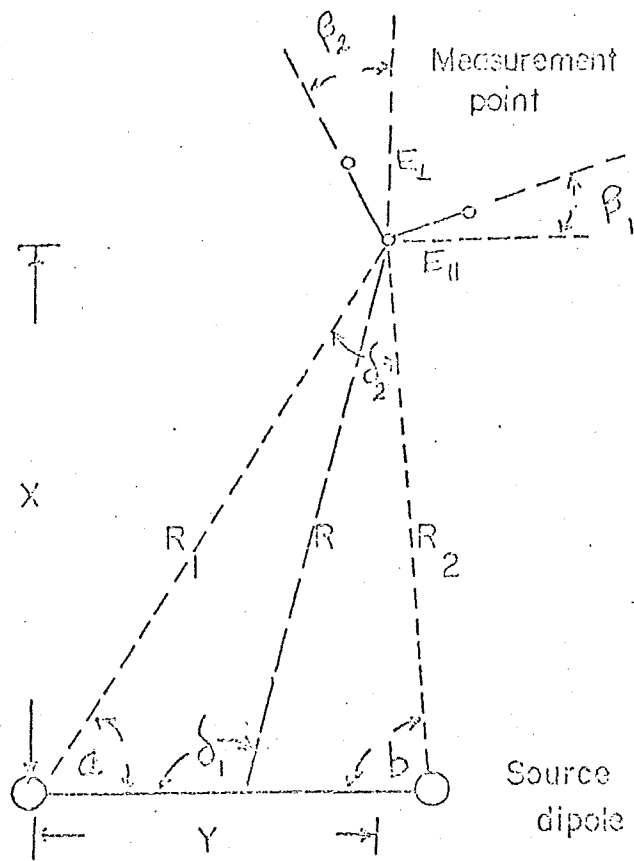

PARALLEL $\rho_a = \frac{2\pi}{\left(\frac{\cos a}{R_1^2} + \frac{\cos b}{R_2^2}\right)} \frac{E_{11}}{I}$

PERPENDICULAR $\rho_a = \frac{2\pi}{\left(\frac{\sin a}{R_1^2} - \frac{\sin b}{R_2^2}\right)} \frac{E_1}{I}$

TOTAL-FIELD $\rho_a = \frac{2\pi R_1^2}{\left[1 + (R_1/R_2)^4 - 2(R_1/R_2)^2 \cos \delta_2\right]^{1/2}} \frac{E_T}{I}$

CONDUCTANCE $S_a = \frac{\left[1 + (R_1/R_2)^2 - 2(R_1/R_2) \cos \delta_2\right]^{1/2}}{2\pi R_1^2} \frac{I}{E_T}$

Figure 17. Layout of electrodes for a dipole mapping survey and formulas used in computing apparent resistivity.

the ratio of voltage drop to the separation between the measuring electrodes. Measurements were made with receiving electrode separations of 30 or 100 meters, usually, with the longer separations being used in areas where the signal strength was low. The receiver consisted of a sensitive DC voltmeter, on which the deflection as current flow reversed was measured. At its maximum sensitivity, deflections as small as 5 or 10 microvolts could be recognized on the voltmeter. Readings of less than 20 microvolts were not normally recorded as useful data.

The primary data obtained from the eight dipole mapping surveys carried out in the Valles Caldera area are listed in the Table accompanying this appendix. These data may be converted to apparent resistivity values using several different formulas. The conventional manner of defining apparent resistivity is to consider what resistivity a uniform earth would have to have to provide the voltages actually observed in the real earth. In a uniform earth, current spreads out from a single electrode with spherical symmetry. The electric field on the surface of the earth at a distance R_1 from a single electrode through which a current I is passing is then:

$$E_1 = \frac{\rho I}{2\pi R_1^2}$$

where ρ is the resistivity of the assumed uniform earth. When a dipole pair of electrodes is used for a current source, there is a second contribution to the electric field from the current flowing through the second electrode:

$$E_2 = \frac{-\rho I}{2\pi R_2^2}$$

where R_2 is the distance from the observation point to the second current electrode.

The electric fields E_1 and E_2 are vector quantities, and so must be added vectorially. The vector sum is:

$$E_T = \frac{\rho I}{2\pi R_1^2} \left[1 + \left(\frac{R_1}{R_2}\right)^4 - 2 \left(\frac{R_1}{R_2}\right)^2 \cos(a_1 - a_2) \right]^{1/2}$$

Solving this expression for ρ provides the means for computing apparent resistivity under the assumption of spherically symmetric spreading of current in a uniform earth. Values for apparent resistivity computed with this formula are listed in the Table accompanying this Appendix.

The Plates showing contour maps of apparent resistivity about the 7 dipoles (Plates 1,3,5,7,9) indicate that apparent resistivity increases consistently with increasing distance from the source. This behavior is typical of dipole mapping surveys carried out in an area where conductive rocks overlie

highly resistant substratum, such as crystalline basement rocks. In this case, the apparent resistivity increases linearly with distance from the source dipole for distances greater than the depth to the resistant rock. Because the current is constrained to flow almost entirely in the surface layer of conductive rock, the calculation of resistivity on the basis of an assumed spherical spreading of the current seems inappropriate. In this case, a more meaningful way to reduce the field data might be to use a formula based on the assumption of cylindrical spreading. For current spreading through a plate, the electric field depends on the ratio of plate thickness to resistivity, h/ρ , a quantity which is also known as the conductance of the plate, S . The electric field at the surface of the plate for a current I to a single electrode is:

$$E_1 = \frac{I}{2\pi SR_1}$$

where R_1 again is the distance from the first current electrode to the observation point. With the addition of a second electrode to complete the dipole current source, the contribution of a second electric field at the observation point must be considered:

$$E_2 = \frac{-I}{2\pi SR_2}$$

The vector sum of these two electric fields is:

$$E_T = \frac{I}{2\pi SR_1} \left[1 + \left(\frac{R_1}{R_2} \right)^2 - 2 \left(\frac{R_1}{R_2} \right) \cos (a_1 - a_2) \right]^{1/2}$$

Solving this expression for S provides the means for computing apparent conductance under the assumption of cylindrically symmetric spreading of current in a uniform conducting plate. Values for apparent conductance computed with this formula are also listed in the Table accompanying this Appendix.

It must be stressed that the apparent values for resistivity or conductance are the actual values only in the case in which the structure of the earth is as simple as that assumed in defining these quantities. That is, the earth must be completely uniform laterally. However, if a conductive geothermal reservoir is present in the survey area, we expect this condition to be violated. When lateral changes in resistivity occur, the computed values of apparent resistivity and apparent conductance will be affected, but it is unlikely that the observed values will then be close to the values actually existing in the ground. In this case, it is desirable to calculate how the apparent values are affected by simple models of inhomogeneous earth structures.

A. Behavior of apparent resistivity and apparent conductance when the earth is layered.

The dipole maps shown on the following two pages are typical of those for a simple two-layer earth. In each case, it is assumed that a dipole with unit length is placed on the surface of an earth in which a layer of unit thickness lies on top of an infinitely thick substratum. The dipole maps on the first of these two pages (Figures 18 and 19) pertain to an infinitely resistant basement. The surface layer is assumed to have unit resistivity. As may be seen, the contours of apparent resistivity form elliptical patterns about the source dipole, a behavior that is characteristic of layering on dipole maps. The eccentricity of the ellipses reflects the well-known fact that measurements made along the polar axis of a dipole source do not detect the presence of a resistant basement until larger spacings are reached than are required when measurements are made along the equatorial axis (Keller, 1966). It should also be noted that there are two small regions about the ends of the dipole where the apparent resistivity is lower than unity, the resistivity assigned to the surface layer.

In contrast to the large variations in apparent resistivity as a function of distance from the source, the values of apparent conductance show very little change over most of the map, after reaching some 70 percent of the correct value of S for the surface layer at a distance of about one unit from the dipole.

The patterns in Figures 18 and 19 were computed for a layer of unit resistivity and unit thickness resting on an infinitely thick substratum with a resistivity of 0.33. Here, both the apparent conductance and the apparent resistivity vary strongly with distance from the source. It may also be noted that in this case, the depth of penetration for measurements made along the polar axis of the dipole source is about the same as for measurements made along the equatorial axis.

A. Apparent conductance

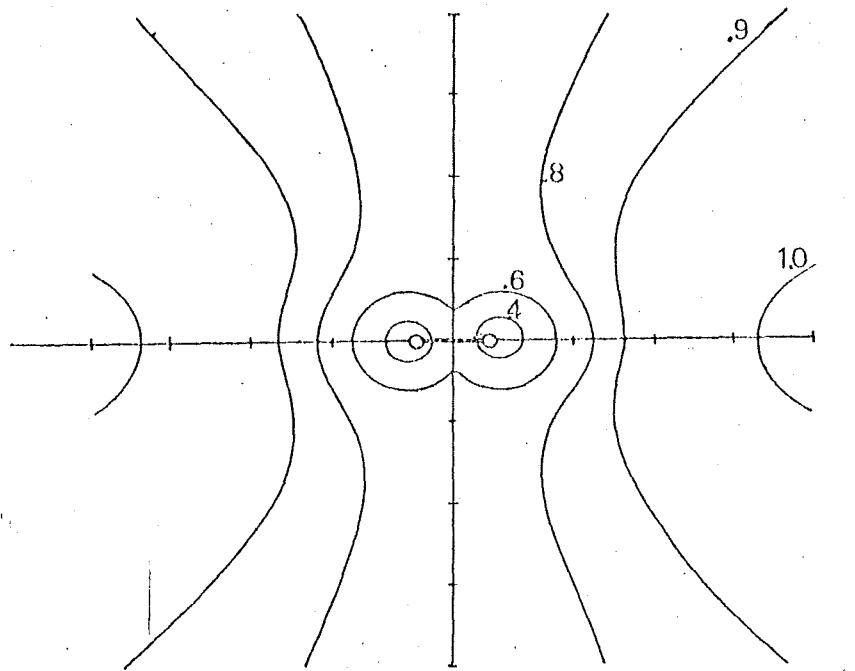

B. Apparent resistivity

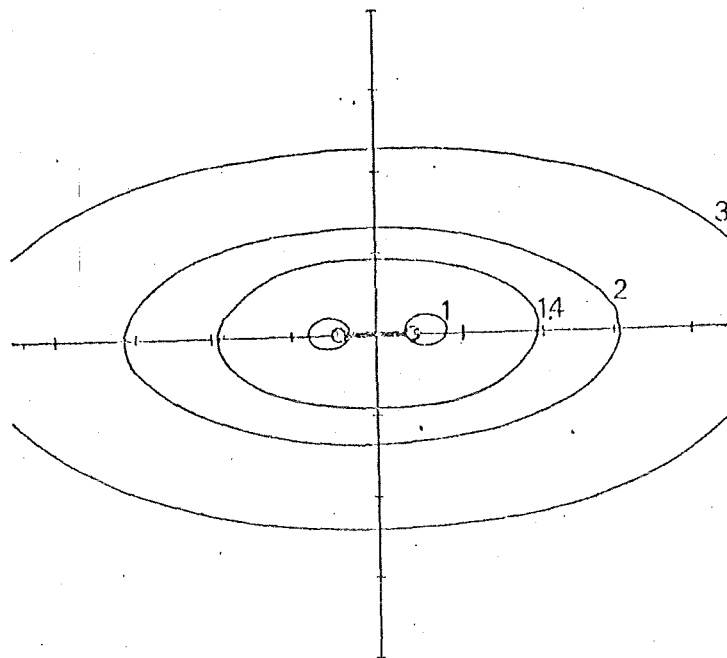
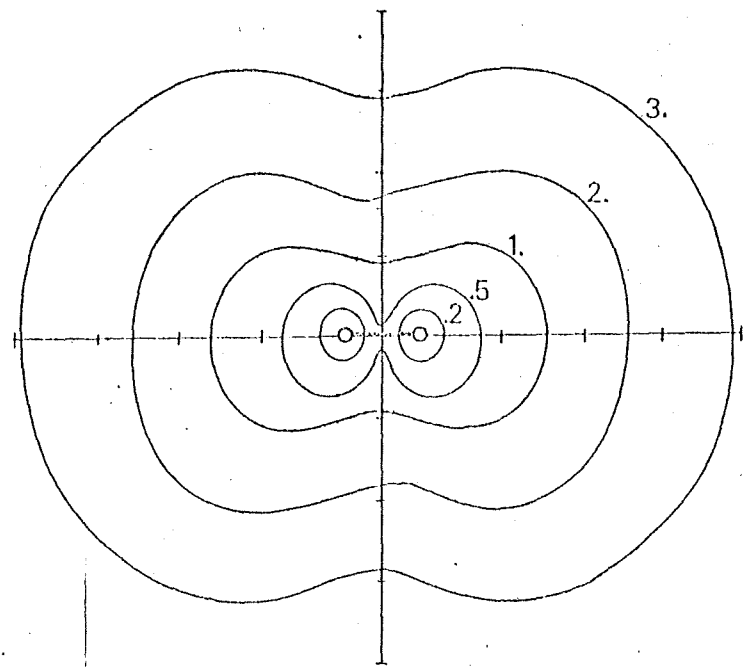

Figure 18. Dipole resistivity patterns for the case of a two-layer sequence in which the second layer is a perfect insulator and the surface layer has unit resistivity. The thickness of the surface layer is one unit, and the source dipole length is one unit.

GROUP SEVEN

A. Apparent conductance



B. Apparent resistivity

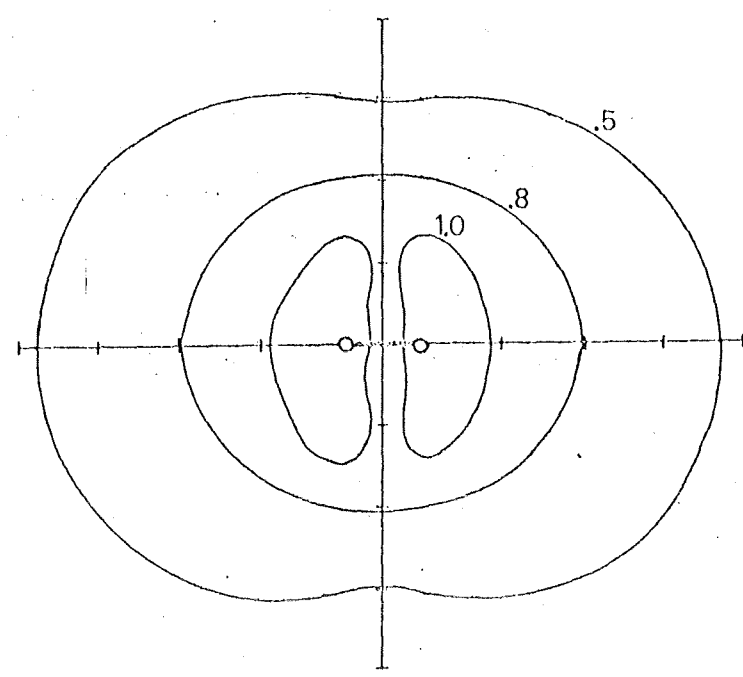

Figure 19. Dipole resistivity patterns for the case of a two-layer sequence in which the first layer has unit resistivity and the second layer has a resistivity of 0.3. The thickness of the surface layer is one unit, and the source dipole length is one unit.

B. Behavior of apparent resistivity and apparent conductance in the presence of a dike-like conductive structure.

The dipole maps shown on the following two pages were computed for a source located at the edge of and parallel to a dike-like feature assumed to have a lower resistivity than the country rock. The country-rock resistivity is taken to be 10 units, while the resistivity within the dike is taken to be 1 unit, or smaller by a factor of 10. The maps in Figure 20 are computed for a very great depth to insulating basement, while the maps in Figure 21 are computed for a depth to insulating basement of 1 unit.

The most striking feature of these maps is the fact that the contrast in apparent conductance values or apparent resistivity values for measurements made inside of and outside of the conductive strip is much smaller than the actual contrast. The true conductance outside the dike, for the case shown in Figure 20, is 0.1 unit, compared to 1 unit for the dike. The observed conductances outside the dike are too large by a factor of 2 to 3, mainly because much of the current that would normally flow in such regions has been diverted to flow inside the dike. Similarly, the higher than normal current concentration within the dike makes the conductance values observed there somewhat too low.

A. Apparent conductance

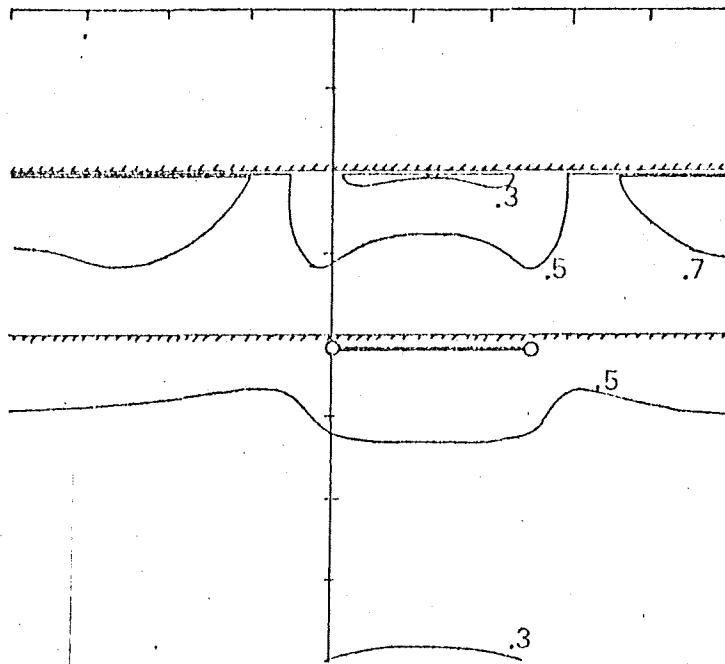

B. Apparent resistivity

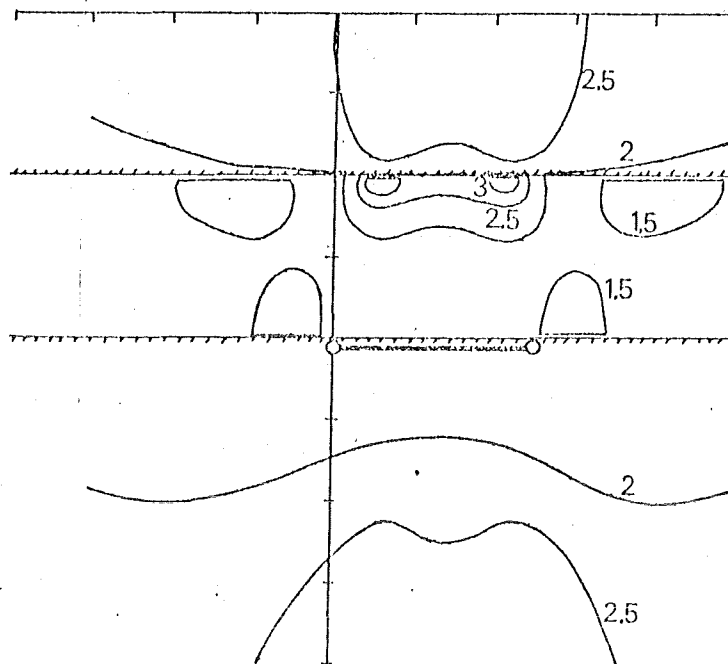
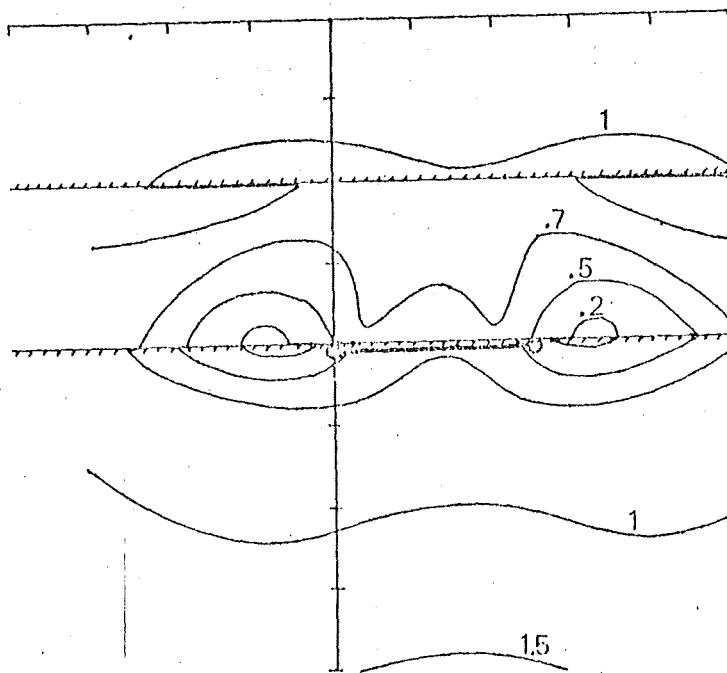

Figure 20. Dipole resistivity patterns for the case of a conductive dike-like feature. Dipole source is 2.5 units long, dike width is 2 units, and the depth to insulating basement is infinite. Dike resistivity is 1 unit, while environmental resistivity is 10 units.

A. Apparent conductance



B. Apparent resistivity

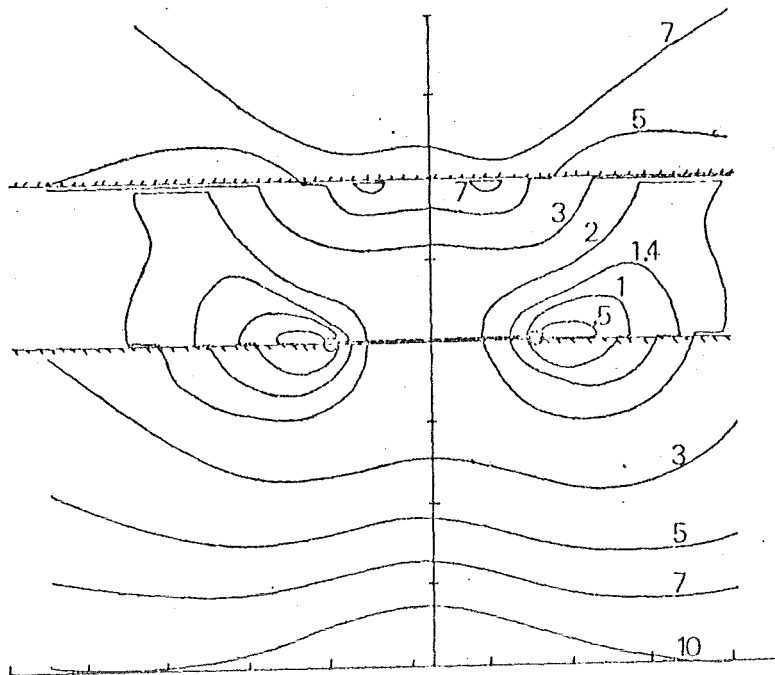

Figure 21. Dipole resistivity patterns for the case of a conductive dike-like feature. Dipole source is 2.5 units long, dike width is 2 units, and the depth to insulating basement is 1 unit. Dike resistivity is 1 unit, while environmental resistivity is 10 units.

C. Behavior of apparent resistivity and apparent conductance in the presence of a dike-like resistive structure.

Computations for this case complement the computations for the preceding case of a conductive dike-like feature. Again, the source dipole length is taken to be 2.5 units long, situated parallel to the edge of a resistant dike-like feature of width 2 units. The country-rock resistivity remains 10 units, but the dike is now assigned a resistivity of 100 units, or 10 times greater than that of the country rock. The maps in Figure 22 are computed for a depth to basement that is very large, while the maps in Figure 23 are computed for a depth to insulating basement of 1 unit.

As in the preceding case, the contrast in observed resistivities and conductivities between the dike and the surrounding rock is subdued.

A. Apparent conductance

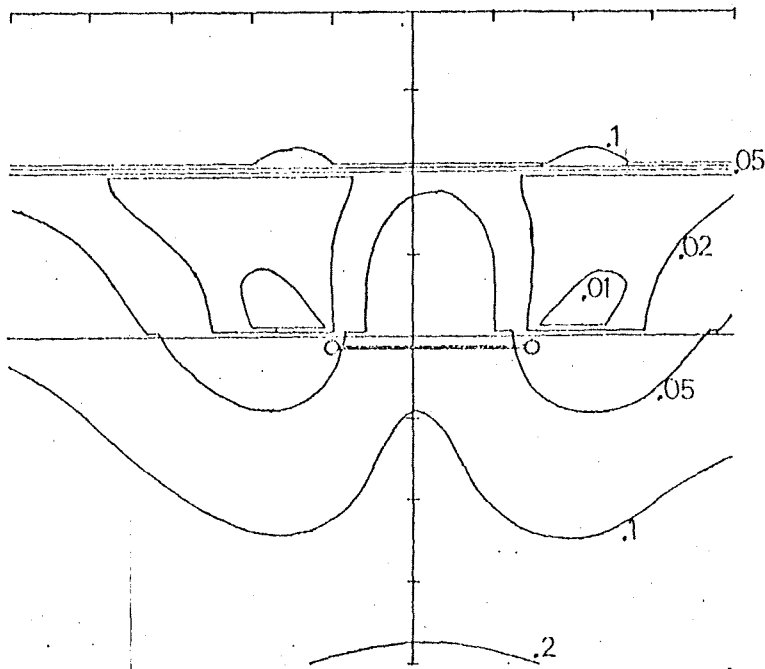

B. Apparent resistivity

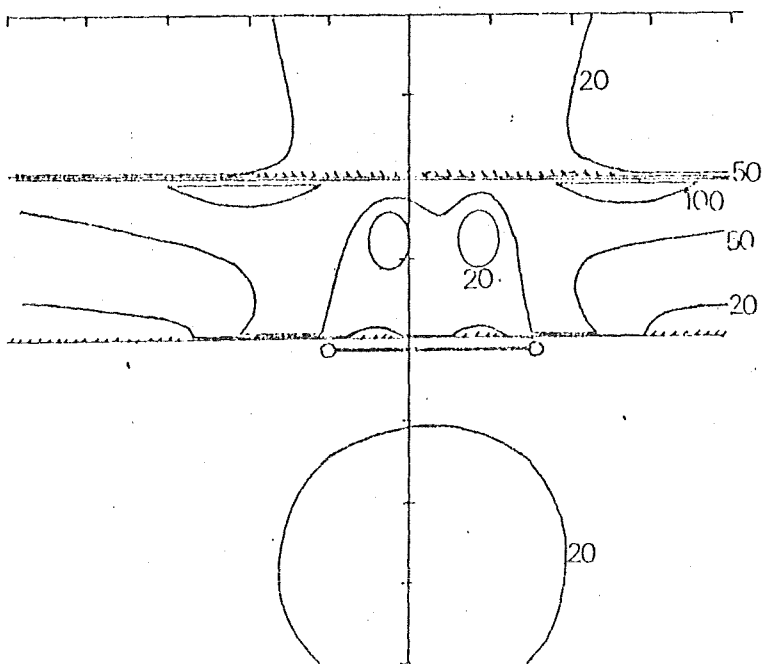
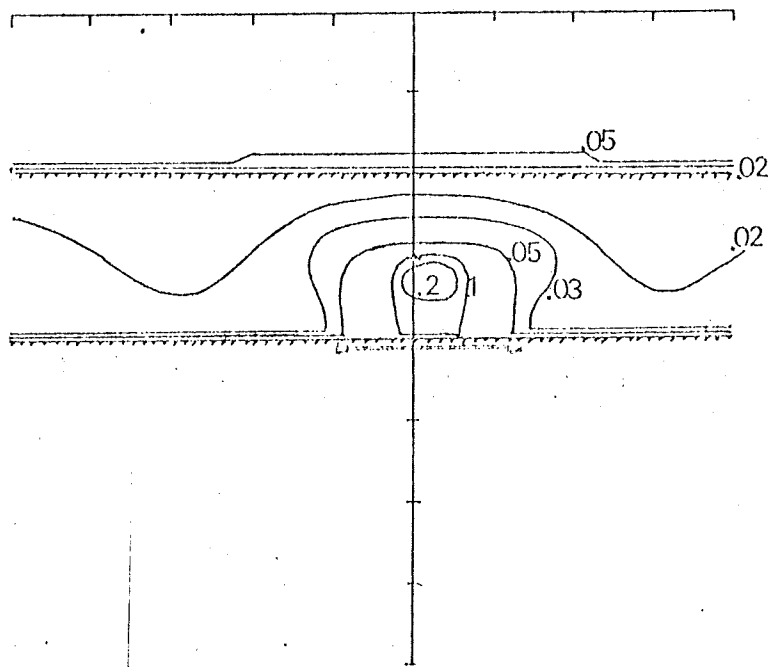

Figure 22. Dipole resistivity patterns for the case of a resistant dike-like feature. Dipole source is 2.5 units long, dike width is 2 units, and the depth to insulating basement is infinite. Dike resistivity is 100, while environmental resistivity is 10.

GROUP SEVEN

A. Apparent conductance



B. Apparent resistivity

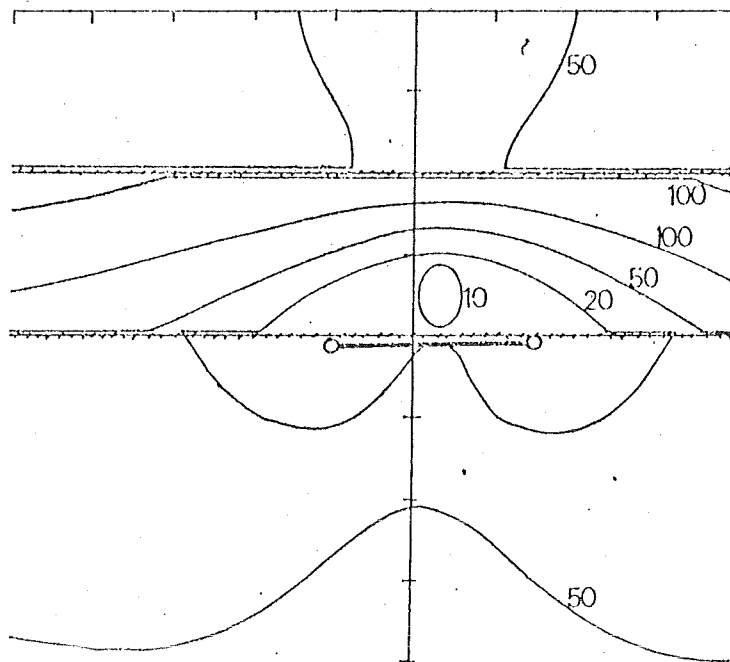

Figure 23. Dipole resistivity patterns for the case of a resistant dike-like feature. Dipole source is 2.5 units long, dike width is 2 units, and depth to insulating basement is 1 unit. Dike resistivity is 100, while environmental resistivity is 10.

APPENDIX I: Tabulation of Data (observed data from dipole resistivity surveys)

The following quantities are listed in the tables;

- N Station number, keyed to Plates 1-10
- R1 Distance from observation point to one end of source dipole, measured in kilometers
- R2 Distance from observation point to the other end of source dipole, measured in kilometers
- D The angle between the two lines R1 and R2 running from an observation point to the two ends of the source dipole
- T The angle between the two directions in which electric field measurements were made at each site (nominally 90°)
- V1 Voltage measured between one pair of receiver electrodes, in microvolts
- V2 Voltage measured between the other pair of receiver electrodes, in microvolts
- X Length of receiver line, in meters
- I Amplitude of current steps, in amperes (average current was one-half this value)
- RT Apparent resistivity computed using the magnitude of the electric field, in ohm-meters
- SA Apparent conductance computed using the magnitude of the electric field, in mhos

APPENDIX I.

Source 1

N	R1	R2	D	T	V1	V2	X	I
1	0.840	2.880	42.	93.	450.	70.	30.	13.3
2	1.420	3.360	34.	78.	280.	-75.	30.	13.3
3	1.190	3.160	36.	94.	-480.	-35.	30.	13.3
4	0.440	2.620	39.	80.	-950.	120.	30.	13.3
5	3.200	1.040	27.	91.	400.	-120.	30.	13.3
6	3.630	1.520	23.	84.	-200.	110.	30.	14.0
7	3.900	1.850	22.	102.	-40.	-117.	30.	14.0
8	4.840	2.700	14.	99.	55.	23.	30.	14.0
9	5.250	3.090	12.	86.	-38.	55.	30.	14.0
10	4.630	2.400	9.	93.	60.	-80.	30.	14.0
11	4.070	1.800	7.	100.	100.	38.	30.	14.0
12	3.500	1.200	0.	78.	-65.	-228.	30.	14.0
13	3.500	1.350	16.	107.	27.	-128.	30.	14.0
14	2.990	0.950	37.	98.	115.	-280.	30.	14.0
15	3.050	1.310	44.	96.	-260.	-39.	30.	14.0
16	3.450	1.970	41.	106.	-145.	50.	30.	14.0
17	3.380	2.350	44.	93.	-38.	-165.	30.	14.0
18	3.320	2.700	45.	93.	-165.	-43.	30.	14.0
19	3.900	4.510	33.	166.	80.	-18.	30.	14.0
20	3.900	4.200	35.	92.	70.	65.	30.	14.0
21	3.780	1.900	31.	102.	-67.	170.	30.	14.0
22	3.640	1.590	27.	87.	145.	50.	30.	14.0
23	2.800	5.100	1.	93.	-20.	38.	30.	14.0
24	3.350	5.650	1.	93.	47.	30.	30.	14.0
25	3.780	6.100	5.	93.	37.	15.	30.	14.0
26	3.600	5.840	8.	106.	-52.	40.	30.	14.0
27	3.600	5.780	10.	90.	-37.	135.	30.	14.0
28	1.100	2.070	89.	97.	-1250.	950.	30.	14.0
29	0.840	2.050	100.	89.	-1480.	-850.	30.	14.0
30	0.530	2.670	47.	100.	400.	900.	30.	14.0
31	0.810	3.080	16.	90.	500.	370.	30.	14.0
32	1.550	3.800	7.	90.	185.	45.	30.	14.0
33	2.320	4.550	11.	90.	80.	310.	90.	14.0
34	3.650	5.700	14.	90.	105.	30.	90.	14.0
35	3.020	5.120	14.	90.	-90.	0.	90.	14.0
36	5.520	3.550	18.	91.	0.	-45.	30.	14.0
37	5.760	4.090	19.	88.	-40.	-6.	30.	14.0
38	6.380	4.700	17.	98.	-32.	-18.	30.	14.0
39	6.570	5.220	18.	89.	-38.	23.	30.	14.0
40	5.880	4.900	22.	105.	42.	-55.	30.	14.0
41	5.180	4.500	27.	93.	-100.	-50.	30.	14.0
42	4.400	4.050	32.	87.	-130.	-45.	30.	14.0
43	4.050	3.940	34.	78.	-102.	0.	30.	14.0
44	3.840	4.060	34.	89.	-62.	0.	30.	14.0
45	3.690	4.200	33.	80.	-40.	210.	30.	14.0

GROUP SEVEN

APPENDIX I.

Source 1

N	RI	RT	SA
1	0.840	5.44	138.9
2	1.420	11.53	99.2
3	1.190	12.15	80.3
4	0.440	3.10	127.2
5	1.040	7.81	106.5
6	1.520	9.84	116.7
7	1.850	8.62	158.5
8	2.700	9.86	186.4
9	3.090	14.87	138.0
10	2.400	11.44	141.1
11	1.800	6.88	182.8
12	1.200	5.58	160.2
13	1.350	4.08	246.1
14	0.950	4.26	186.6
15	1.310	7.85	143.2
16	1.970	10.77	158.9
17	2.350	19.30	115.3
18	2.700	26.61	102.4
19	3.900	104.72	36.8
20	3.900	38.45	103.0
21	1.900	11.77	127.0
22	1.590	6.84	178.8
23	2.800	7.07	255.9
24	3.350	14.76	142.5
25	3.780	14.05	168.2
26	3.600	18.12	126.6
27	3.600	43.67	53.2
28	1.100	26.05	45.9
29	0.840	17.13	53.8
30	0.530	4.58	104.3
31	0.810	6.53	99.8
32	1.550	8.18	135.4
33	2.320	11.50	137.5
34	3.650	11.87	206.0
35	3.020	6.13	332.7
36	3.550	13.68	182.5
37	4.090	18.36	163.1
38	4.700	25.40	134.6
39	5.220	40.74	100.7
40	4.900	50.62	84.7
41	4.500	73.00	59.1
42	4.050	62.77	65.1
43	3.940	42.46	93.8
44	3.840	24.33	160.2
45	3.690	83.27	44.1

GROUP SEVEN

APPENDIX I.

Source 1

N	R1	R2	D	T	V1	V2	X	I
46	3.570	4.420	31.	100.	28.	-165.	30.	14.0
47	3.960	4.670	30.	94.	37.	15.	30.	14.0
48	4.300	4.930	27.	91.	-120.	-45.	30.	13.3
49	4.380	4.860	28.	99.	62.	-25.	30.	13.3
50	4.920	5.030	26.	95.	60.	0.	30.	13.3
51	1.300	1.080	159.	90.	-430.	2500.	30.	13.3
52	1.500	0.830	180.	90.	-600.	-285.	30.	13.3
53	1.200	1.180	159.	90.	-600.	-2500.	30.	13.3
54	2.040	3.880	30.	90.	-90.	-198.	30.	13.3
55	2.110	4.500	24.	90.	115.	83.	30.	13.3
56	2.120	4.660	20.	90.	-7.	-80.	30.	13.3
57	2.560	4.770	13.	90.	-88.	-70.	30.	13.3
58	2.310	4.600	8.	90.	33.	-134.	30.	13.3
59	2.120	4.420	5.	90.	-60.	32.	30.	13.3
60	4.820	6.780	12.	90.	0.	-60.	90.	13.3
61	4.500	5.550	24.	96.	0.	-70.	30.	14.0
62	4.040	5.170	25.	95.	-42.	-13.	30.	14.0
63	3.930	5.280	24.	100.	-55.	32.	30.	14.0
64	3.350	4.880	25.	119.	-90.	90.	30.	13.3
65	2.650	3.720	38.	106.	170.	-40.	30.	13.3
66	2.560	3.170	46.	88.	22.	200.	30.	13.3
67	3.660	5.480	19.	98.	-270.	155.	30.	13.3
68	3.970	5.920	15.	104.	120.	-35.	30.	13.3
69	4.770	7.000	5.	93.	25.	8.	30.	12.6
70	4.420	6.530	10.	120.	100.	-5.	30.	12.6
71	4.030	5.900	16.	85.	-150.	-130.	30.	12.6
72	5.200	6.190	21.	88.	-8.	-25.	30.	12.6
73	6.770	7.780	17.	104.	15.	-4.	30.	12.6
74	2.250	3.510	41.	99.	-130.	-70.	30.	15.4
75	2.140	2.750	53.	103.	-145.	-300.	30.	15.4
76	2.750	2.280	55.	96.	-60.	-40.	30.	13.3
77	3.200	2.270	47.	104.	0.	90.	30.	13.3
78	6.400	6.800	20.	91.	-40.	-40.	30.	13.3
79	7.030	7.130	19.	100.	20.	25.	30.	13.3
80	4.800	5.700	23.	75.	20.	-10.	30.	13.3
81	5.030	4.790	27.	91.	70.	-35.	30.	13.3
82	5.070	5.070	26.	80.	-63.	42.	30.	13.3
83	4.500	4.850	28.	100.	-20.	50.	30.	13.3
84	4.650	3.330	27.	90.	42.	180.	30.	13.3
85	4.900	3.250	23.	94.	90.	-60.	30.	13.3
86	4.870	3.080	21.	87.	105.	100.	30.	13.3
87	4.970	3.000	17.	88.	65.	140.	30.	13.3
88	3.420	5.630	11.	90.	11.	13.	30.	12.6
89	3.820	5.470	21.	113.	-74.	22.	30.	12.6
90	3.850	4.980	27.	90.	0.	45.	30.	12.6

GROUP SEVEN

APPENDIX I.

Source 1

N	RI	RT	SA
46	3.570	56.79	58.7
47	3.960	18.44	206.1
48	4.300	79.46	52.0
49	4.380	40.73	106.4
50	4.920	51.02	97.2
51	1.080	28.03	41.7
52	0.830	5.51	179.2
53	1.180	29.10	40.9
54	2.040	18.41	86.6
55	2.110	12.34	128.1
56	2.120	7.02	221.4
57	2.560	16.05	108.3
58	2.310	15.45	100.8
59	2.120	6.25	230.6
60	4.820	14.16	223.0
61	4.500	44.36	88.5
62	4.040	21.38	161.3
63	3.930	25.37	125.6
64	3.380	31.33	85.0
65	2.650	27.65	88.2
66	2.560	28.52	90.8
67	3.680	106.30	24.9
68	3.970	51.63	52.3
69	4.770	18.55	156.4
70	4.420	65.83	42.8
71	4.080	94.26	30.2
72	5.200	27.51	164.8
73	6.770	32.33	180.3
74	2.280	15.25	134.9
75	2.140	28.70	76.4
76	2.280	7.51	314.9
77	2.270	9.99	220.7
78	6.400	106.27	59.5
79	7.030	83.71	84.3
80	4.800	20.81	206.8
81	4.790	61.96	78.0
82	5.070	73.33	69.1
83	4.500	34.87	129.5
84	3.330	54.59	50.2
85	3.250	28.20	87.0
86	3.080	32.80	68.4
87	3.000	32.67	63.7
88	3.490	5.36	426.8
89	3.820	31.52	90.8
90	3.850	20.52	162.7

GROUP SEVEN

APPENDIX I.

Source 1

N	R1	R2	D	T	V1	V2	X	I
91	4.560	4.660	28.	90.	-36.	-32.	30.	12.6
92	4.880	5.530	25.	101.	-42.	0.	30.	12.6
93	2.670	4.720	16.	90.	25.	75.	30.	13.3
94	2.000	4.070	20.	86.	-20.	90.	30.	13.3
95	1.410	3.500	26.	82.	98.	240.	30.	13.3
96	2.570	3.590	40.	93.	-120.	20.	30.	13.3
97	1.750	3.180	45.	115.	5.	-120.	30.	13.3
98	4.490	6.100	19.	90.	-32.	22.	30.	13.3
99	3.540	5.180	22.	91.	30.	-20.	30.	13.3
701	4.600	5.300	27.	110.	27.	-33.	30.	13.3
702	4.650	5.200	26.	110.	12.	-22.	30.	13.3
703	5.050	5.350	27.	98.	-35.	-10.	30.	13.3
704	5.400	5.400	25.	70.	51.	15.	30.	13.3
705	3.900	5.200	25.	82.	-15.	50.	30.	12.6
706	3.500	5.250	22.	105.	27.	-12.	30.	12.6
707	3.600	5.550	16.	102.	40.	15.	30.	12.6
708	3.550	6.000	7.	103.	15.	10.	30.	14.0
709	4.200	6.500	5.	91.	8.	0.	30.	14.0
710	4.850	7.150	3.	100.	0.	25.	30.	14.0
711	4.600	6.900	5.	84.	0.	10.	30.	13.3
712	4.050	6.250	9.	90.	0.	22.	30.	13.3
713	3.800	5.900	13.	89.	-15.	0.	30.	13.3
714	3.850	5.700	18.	103.	8.	25.	30.	13.3
715	4.700	6.700	12.	97.	0.	-40.	30.	13.3
716	4.800	7.000	8.	89.	-10.	-15.	30.	13.3
717	4.950	7.300	0.	110.	10.	-15.	30.	13.3
719	3.100	5.300	8.	110.	-55.	-25.	30.	12.6
720	2.950	5.250	3.	90.	-17.	-100.	30.	12.6
721	2.950	5.050	15.	95.	130.	0.	30.	12.6
722	3.300	5.650	2.	85.	-15.	-55.	30.	12.6
723	3.950	5.200	9.	87.	-30.	-22.	30.	12.6
724	4.400	5.750	3.	91.	-15.	-15.	30.	12.6
725	4.150	6.400	0.	82.	0.	35.	30.	12.6
726	3.750	6.050	0.	97.	-5.	-45.	30.	12.6
727	3.750	6.050	0.	97.	-5.	-45.	30.	12.6
727	4.450	5.490	9.	80.	0.	50.	30.	12.6
728	5.000	7.200	7.	99.	-17.	-15.	30.	12.6

GROUP SEVEN

APPENDIX I.

N	RI	RT	SA
91	4.560	35.02	131.2
92	4.880	38.37	121.9
93	2.670	12.70	145.2
94	2.000	7.60	190.8
95	1.410	9.08	120.0
96	2.570	18.19	131.7
97	1.750	7.69	202.1
98	4.490	23.80	140.7
99	3.540	11.91	223.8
701	4.600	26.03	169.2
702	4.650	17.03	265.5
703	5.050	33.69	150.9
704	5.400	54.25	99.5
705	3.900	25.41	126.9
706	3.500	9.17	285.0
707	3.600	16.50	149.8
708	3.550	5.85	389.0
709	4.200	3.38	765.7
710	4.850	16.49	176.4
711	4.600	6.00	468.0
712	4.050	9.64	266.6
713	3.800	5.65	445.2
714	3.850	11.34	240.8
715	4.700	26.50	116.1
716	4.800	12.03	248.1
717	4.950	11.34	260.1
719	3.100	17.33	115.7
720	2.950	21.42	88.4
721	2.950	27.90	72.1
722	3.300	15.35	135.9
723	3.950	21.56	115.3
724	4.400	16.51	153.1
725	4.150	17.46	144.2
726	3.750	17.52	132.1
727	3.750	17.52	132.1
727	4.450	45.69	62.9
728	5.000	19.82	154.9

GROUP SEVEN

APPENDIX I.

Source 2

N	R1	R2	D	T	V1	V2	X	I
201	0.760	2.300	174.	90.	600.	375.	27.	12.6
202	1.520	1.500	2.	100.	500.	200.	27.	12.6
203	0.750	2.270	154.	89.	2500.	-450.	27.	12.6
204	9.000	3.390	61.	100.	-120.	-420.	27.	12.6
205	2.950	3.600	57.	162.	-60.	190.	27.	12.6
206	2.850	3.900	51.	87.	-40.	100.	27.	12.6
207	3.380	4.180	45.	76.	-30.	-250.	27.	12.6
208	3.800	4.600	41.	80.	-10.	-105.	27.	12.6
209	4.310	5.000	37.	92.	85.	300.	27.	12.6
210	4.960	5.570	32.	81.	50.	-45.	27.	12.6
211	4.780	5.600	33.	100.	20.	-8.	27.	12.6
212	4.540	5.610	33.	103.	75.	-5.	27.	12.6
213	4.350	5.470	34.	90.	50.	-80.	27.	12.6
214	2.890	4.450	42.	89.	30.	3.	27.	12.6
215	3.350	4.930	37.	90.	-20.	65.	27.	12.6
216	3.670	5.120	35.	95.	-50.	25.	27.	12.6
217	4.070	5.280	35.	103.	-20.	17.	27.	12.6
218	5.070	6.010	30.	85.	12.	25.	27.	12.6
219	5.600	6.530	27.	108.	25.	70.	27.	12.6
220	5.630	6.390	28.	90.	25.	-5.	27.	12.6
221	2.800	3.350	47.	104.	30.	-70.	27.	12.6
222	3.350	3.880	41.	90.	5.	-35.	27.	12.5
223	4.000	4.390	34.	90.	5.	-55.	27.	12.5
224	4.490	4.900	31.	95.	-70.	-55.	27.	12.5
225	5.350	5.650	27.	90.	0.	-30.	27.	11.9
226	5.580	5.670	26.	93.	0.	-25.	27.	11.9
227	6.500	6.580	23.	97.	-30.	70.	27.	11.2
228	6.400	6.730	22.	92.	25.	0.	27.	11.2
229	5.300	6.780	20.	82.	-50.	-50.	27.	11.2
230	4.800	6.610	19.	105.	27.	45.	27.	11.2
231	3.700	5.780	19.	90.	15.	-55.	27.	11.8
232	4.690	6.780	15.	93.	-30.	27.	27.	11.5
233	5.700	7.580	15.	80.	-35.	0.	27.	11.5
234	5.790	7.400	17.	95.	0.	0.	27.	11.5
235	1.200	3.780	18.	96.	-270.	-20.	27.	11.5
235	1.610	4.130	12.	99.	-200.	-70.	27.	11.5
237	2.090	4.610	8.	95.	-80.	-140.	27.	11.5
238	2.710	5.200	10.	87.	-90.	-30.	27.	11.5
239	0.750	3.220	23.	90.	870.	-220.	27.	11.5
240	5.120	7.610	7.	90.	-5.	-8.	30.	11.8
241	4.840	7.300	8.	90.	-5.	-30.	30.	11.8
242	5.400	7.970	5.	90.	0.	0.	30.	11.8
243	4.820	6.390	4.	90.	30.	5.	30.	11.2
244	4.350	6.900	3.	90.	0.	-16.	30.	11.2
245	3.700	6.300	2.	120.	31.	0.	30.	11.2

GROUP SEVEN

APPENDIX I.

Source 2

N	RI	RT	SA
201	0.760	6.80	134.0
202	1.500	598.18	2.1
203	0.750	24.09	37.0
204	3.390	98.23	34.0
205	2.950	81.18	37.8
206	2.850	21.07	135.4
207	3.380	75.06	45.4
208	3.800	42.60	89.2
209	4.310	178.74	24.1
210	4.960	61.80	80.2
211	4.780	15.61	300.2
212	4.540	50.33	85.6
213	4.350	55.73	73.7
214	2.890	6.26	420.3
215	3.350	20.46	145.6
216	3.670	20.75	158.5
217	4.070	11.82	321.5
218	5.070	24.38	198.9
219	5.600	100.98	52.4
220	5.630	31.05	176.8
221	2.800	14.13	202.4
222	3.350	11.27	301.1
223	4.000	29.46	137.2
224	4.490	67.75	66.7
225	5.350	37.03	145.6
226	5.580	34.38	163.3
227	6.500	163.33	40.0
228	6.400	55.62	115.2
229	5.300	81.44	51.7
230	4.800	54.27	65.5
231	3.700	24.56	107.2
232	4.690	31.77	100.8
233	5.700	48.74	83.1
234	5.790	6.6	500.0
235	1.200	8.83	105.9
235	1.610	13.81	85.4
237	2.090	18.58	78.3
238	2.710	18.91	96.7
239	0.750	10.75	58.1
240	5.120	7.92	399.8
241	4.840	22.24	136.2
242	5.400
243	4.820	30.40	92.4
244	4.350	9.38	285.9
245	3.700	13.94	167.4

GROUP SEVEN

APPENDIX I.

Source 2

N	R1	R2	D	T	V1	V2	X	I
246	4.000	6.240	5.	87.	-20.	24.	30.	11.8
247	3.020	5.500	11.	90.	60.	-45.	30.	11.8
248	2.700	5.040	17.	90.	22.	-120.	30.	11.8
249	2.810	4.790	24.	90.	-30.	-100.	30.	11.8
250	2.400	4.320	33.	90.	0.	-180.	30.	11.8
251	1.400	2.750	68.	85.	-460.	50.	30.	12.6
252	1.800	3.340	42.	87.	350.	170.	30.	12.6
253	2.000	4.070	31.	92.	135.	75.	30.	12.6
254	2.250	4.520	20.	83.	35.	-100.	30.	12.6
255	1.600	4.140	12.	83.	-150.	175.	30.	12.6
256	2.150	4.750	0.	91.	75.	16.	30.	12.6
257	4.300	6.830	5.	87.	25.	0.	30.	12.6
258	5.200	7.690	6.	79.	0.	-30.	30.	12.6
259	3.450	6.020	3.	101.	-17.	-40.	30.	12.6
260	3.000	5.550	0.	107.	0.	15.	30.	12.6
261	3.100	5.550	11.	90.	-16.	0.	30.	12.6
262	3.000	5.530	7.	104.	-5.	-20.	30.	12.6
263	3.200	5.600	15.	120.	17.	-35.	30.	12.6
264	4.250	6.720	8.	90.	15.	7.	30.	12.6
265	3.700	6.140	5.	91.	0.	-15.	29.	12.6
266	4.000	6.580	0.	88.	10.	-5.	29.	12.6
267	4.650	7.250	0.	105.	0.	-9.	29.	12.6
268	4.850	7.400	3.	103.	8.	13.	29.	12.6
269	3.500	5.870	13.	106.	-15.	-17.	30.	11.9
270	4.730	6.800	16.	93.	-22.	13.	30.	11.9
271	3.910	6.150	16.	84.	-8.	32.	30.	11.9
272	4.090	5.890	22.	92.	40.	-27.	30.	11.2
273	6.160	7.910	15.	88.	-20.	10.	30.	11.2
274	3.870	5.350	27.	111.	25.	-40.	30.	10.5
275	3.060	4.400	36.	97.	27.	-55.	30.	10.5
276	3.640	4.650	33.	87.	20.	80.	30.	10.5
277	2.020	3.290	52.	95.	165.	100.	30.	10.5
278	2.020	2.020	80.	82.	180.	-210.	30.	10.5
279	2.390	3.100	54.	86.	100.	-245.	30.	10.5
280	4.080	4.830	32.	80.	-220.	-100.	30.	10.5
281	4.820	5.600	27.	89.	-105.	90.	30.	10.5
282	6.330	6.690	23.	90.	95.	0.	30.	10.5
283	1.000	3.300	40.	108.	-50.	300.	30.	11.8
284	1.700	3.700	36.	90.	90.	-40.	30.	11.8
285	2.400	4.300	29.	90.	60.	-70.	30.	11.8
286	3.200	5.100	26.	106.	30.	-40.	30.	11.8
287	3.900	5.500	25.	87.	30.	0.	30.	11.2
288	4.700	6.000	24.	90.	-30.	-120.	30.	11.2
289	5.300	6.600	22.	90.	0.	42.	30.	11.2
290	5.700	7.000	20.	109.	25.	20.	30.	11.2

GROUP SEVEN

APPENDIX I.

Source 2

N	RI	R T	SA
246	4.000	15.41	160.4
247	3.020	17.20	117.5
248	2.700	21.61	87.6
249	2.810	20.89	100.3
250	2.400	24.21	80.0
251	1.400	16.36	85.8
252	1.200	10.04	101.5
253	2.000	12.97	121.3
254	2.250	12.08	134.8
255	1.600	12.25	95.8
256	2.150	7.43	199.2
257	4.300	12.69	210.7
258	5.200	25.10	126.8
259	3.450	13.95	157.8
260	3.000	3.31	588.3
261	3.100	3.67	563.1
262	3.000	4.72	417.8
263	3.300	9.44	238.1
264	4.250	8.18	328.8
265	3.600	5.08	451.4
266	4.000	4.95	502.3
267	4.650	5.88	432.0
268	4.850	11.56	254.8
269	3.500	8.83	264.7
270	4.730	18.01	182.3
271	3.910	14.86	180.6
272	4.090	25.72	120.5
273	6.160	36.38	122.0
274	3.870	21.29	150.5
275	3.060	16.38	166.4
276	3.640	36.55	92.4
277	2.020	19.85	97.4
278	2.020	18.91	106.8
279	2.390	38.33	63.9
280	4.080	138.96	28.4
281	4.820	135.49	33.8
282	6.330	194.14	32.6
283	1.000	5.77	147.2
284	1.700	6.03	229.8
285	2.400	12.70	147.2
286	3.200	12.13	203.2
287	3.900	14.63	212.7
288	4.700	101.06	39.3
289	5.300	47.60	93.6
290	5.700	53.57	88.1

GROUP SEVEN

APPENDIX I.

Source 2

N	R1	R2	D	T	V1	V2	X	I
291	6.100	7.300	19.	95.	25.	-10.	30.	11.8
292	6.800	7.900	18.	90.	0.	-20.	30.	11.8
293	7.500	8.800	16.	90.	0.	-10.	30.	11.8
294	4.650	6.200	21.	92.	-22.	5.	30.	11.5
295	5.550	6.450	23.	92.	20.	0.	30.	11.5
296	5.850	6.550	22.	79.	25.	0.	30.	11.5
227	6.650	7.000	22.	90.	20.	20.	30.	11.5
298	7.000	7.300	20.	88.	20.	0.	30.	11.5
299	4.700	5.750	26.	90.	10.	-50.	30.	11.5
300	4.250	5.600	25.	90.	10.	-25.	30.	11.5
756	2.350	5.400	3.	85.	-1900.	350.	30.	12.6
757	1.150	3.650	6.	90.	190.	140.	30.	12.6
758	3.000	4.300	38.	90.	97.	65.	30.	12.6
759	2.150	3.700	42.	90.	75.	-70.	30.	12.6
760	2.000	2.500	70.	116.	350.	-90.	30.	12.6
761	1.400	3.900	16.	90.	185.	0.	30.	12.6
762	2.400	4.700	21.	90.	0.	-50.	30.	12.6
763	3.250	5.450	18.	100.	35.	0.	30.	12.6
764	3.850	6.250	14.	90.	20.	-10.	30.	12.6
765	5.300	7.300	11.	90.	20.	10.	30.	12.6
766	7.350	9.500	10.	80.	10.	0.	30.	12.6
767	5.250	7.200	16.	90.	0.	-20.	30.	12.6
768	5.800	7.800	13.	90.	0.	15.	30.	12.6
769	6.650	8.750	12.	90.	0.	-10.	30.	12.6
770	6.200	8.400	12.	90.	-10.	20.	30.	12.6
773	4.500	6.600	16.	90.	20.	0.	30.	12.6
774	4.750	6.500	18.	91.	10.	-35.	30.	12.6
775	3.800	6.200	11.	100.	-20.	20.	30.	12.6

GROUP SEVEN

APPENDIX I.

N	RI	RT	SA
291	6.100	42.38	120.9
292	6.800	43.94	133.2
293	7.600	29.32	216.6
294	4.650	17.48	207.5
295	5.550	26.11	195.2
296	5.850	40.10	138.4
227	6.650	60.66	109.6
298	7.000	52.19	134.1
299	4.700	41.45	102.0
300	4.250	16.53	214.4
756	2.850	368.33	5.1
757	1.150	5.75	152.7
758	3.000	25.46	106.9
759	2.150	10.09	187.4
760	2.000	24.08	88.0
761	3.900	63.44	42.9
762	2.400	6.28	277.9
763	3.250	9.29	245.2
764	3.850	8.64	299.5
765	5.300	21.15	162.1
766	7.350	21.54	220.2
767	5.250	17.95	206.4
768	5.800	17.55	222.8
769	6.650	16.28	272.6
770	6.200	29.75	137.6
771	1.250	4.55	285.0
772	1.600	8.17	185.3
773	4.500	11.85	262.3
774	4.750	26.20	132.5
775	3.800	9.87	251.5

GROUP SEVEN

APPENDIX I.

Source 3

N	R1	R2	D	T	V1	V2	X	I
301	0.850	3.200	9.	90.	1400.	250.	30.	12.6
302	1.800	4.150	0.	90.	120.	-220.	30.	12.6
303	2.600	5.000	3.	84.	70.	0.	30.	12.6
304	3.650	6.000	1.	89.	15.	-10.	30.	12.6
305	4.800	7.150	1.	91.	40.	0.	30.	12.6
306	5.650	8.000	4.	103.	0.	0.	30.	12.6
307	5.250	7.650	1.	90.	0.	0.	30.	12.6
308	4.200	6.600	1.	114.	-15.	0.	30.	12.6
309	5.100	7.500	3.	91.	0.	0.	30.	12.6
310	2.500	4.850	4.	87.	-25.	-57.	30.	12.6
311	1.900	4.150	15.	97.	175.	-50.	30.	12.6
312	2.700	4.500	25.	89.	40.	-35.	30.	12.6
313	3.250	5.000	25.	101.	15.	10.	30.	12.6
314	4.050	5.450	24.	88.	10.	-25.	30.	12.6
315	3.900	4.950	28.	92.	50.	0.	30.	12.6
316	4.100	4.450	33.	84.	110.	0.	30.	12.6
317	4.950	5.200	28.	92.	0.	45.	30.	12.6
318	3.900	4.600	32.	90.	-30.	0.	30.	12.6
319	3.150	5.300	22.	106.	-25.	-35.	30.	12.6
320	4.400	6.000	20.	88.	0.	-25.	30.	12.6
321	0.700	3.050	15.	86.	-1000.	1200.	30.	12.6
322	1.550	3.800	13.	92.	250.	20.	30.	12.6
323	2.500	4.800	6.	90.	70.	-25.	30.	12.6
324	3.200	5.550	7.	92.	42.	-60.	30.	12.6
325	4.050	6.400	5.	90.	40.	-35.	30.	12.6
326	5.000	7.350	5.	95.	-17.	-35.	30.	12.6
327	5.300	8.350	6.	90.	-130.	-110.	30.0	13.
328	6.600	8.900	3.	90.	-13.	5.	30.	12.6
329	2.850	5.130	10.	88.	900.	1300.	30.	12.6
330	3.750	5.900	12.	87.	70.	12.	30.	12.6
331	3.700	5.600	17.	91.	-35.	-10.	30.	12.6
332	4.100	5.800	20.	100.	-20.	-18.	30.	12.6
333	4.800	6.400	19.	90.	-17.	30.	30.	12.6
334	4.250	5.600	23.	93.	-35.	17.	30.	12.6
335	4.450	5.550	25.	90.	0.	0.	30.	12.6
337	3.700	3.800	39.	90.	-5.	-45.	30.	12.6
338	2.750	3.100	47.	84.	0.	-30.	30.	12.6
339	2.050	2.400	64.	83.	45.	70.	30.	12.6
340	1.100	1.500	140.	90.	0.	1400.	30.	12.6
341	1.400	1.000	8.	95.	100.	45.	30.0	13.
342	1.500	2.050	85.	90.	-330.	-80.	30.	12.6
343	4.850	5.000	28.	85.	17.	10.	30.	12.6
344	2.100	3.400	45.	91.	-30.	215.	30.	12.6
345	2.950	4.300	31.	100.	50.	0.	30.	12.6

GROUP SEVEN

APPENDIX I.

Source 3

N	RI	RT	SA
301	0.850	18.34	36.8
302	1.800	16.64	75.5
303	2.600	10.83	158.3
304	3.650	6.39	355.1
305	4.800	27.87	103.1
306	5.650		
307	5.250		
308	4.200	8.07	318.1
309	5.100		
310	2.500	8.69	190.6
311	1.900	13.31	101.8
312	2.700	9.42	216.5
313	3.250	5.43	460.0
314	4.050	13.68	239.9
315	3.900	23.53	147.6
316	4.100	56.81	73.0
317	4.950	39.06	127.9
318	3.900	13.92	272.2
319	3.150	12.06	190.9
320	4.400	15.25	218.2
321	0.700	13.90	41.4
322	1.550	11.97	94.1
323	2.500	10.57	157.0
324	3.200	18.29	113.0
325	4.050	24.09	104.3
326	5.000	30.98	97.8
327	5.300		
328	6.600	22.31	172.5
329	2.850	300.42	6.3
330	3.750	26.96	91.2
331	3.700	13.94	185.0
332	4.100	14.80	205.5
333	4.800	26.30	137.8
334	4.250	22.02	156.6
337	3.700	15.81	236.5
338	2.750	5.14	550.1
339	2.050	5.85	367.6
340	1.100	19.37	63.7
341	1.000		
342	1.500	11.63	140.1
343	4.850	15.73	311.2
344	2.100	20.41	94.2
345	2.950	11.40	218.0

GROUP SEVEN

APPENDIX I.

Source 3

N	R1	R2	D	T	V1	V2	X	I
346	3.400	4.200	35.	102.	30.	-40.	30.	12.6
347	3.250	3.370	43.	110.	5.	80.	30.	12.6
348	2.520	4.200	31.	90.	-65.	55.	30.	12.6
349	1.650	3.530	33.	90.	-1100.	0.	30.	12.6
350	2.100	3.560	40.	96.	-950.	1000.	30.	12.6
351	3.900	4.370	32.	90.	-22.	45.	30.	13.
352	3.320	3.850	38.	85.	-10.	-65.	30.	13.
353	5.950	7.470	15.	90.	-5.	-10.	30.	13.
354	6.730	8.320	14.	90.	-15.	8.	30.	13.
355	6.330	8.300	11.	85.	15.	0.	30.	13.
356	5.600	7.750	9.	107.	30.	0.	30.	13.
357	7.750	9.450	6.	87.	-60.	80.	30.	13.
358	4.320	6.180	1.	90.	-13.	-55.	30.	13.
359	4.400	6.750	4.	88.	-25.	-30.	30.	13.
360	3.200	5.550	2.	90.	-40.	-75.	30.	13.
361	5.100	6.700	17.	86.	0.	0.	30.	12.6
363	4.400	5.350	25.	88.	15.	-27.	30.	12.6
364	5.050	5.900	24.	95.	20.	-22.	30.	12.6
365	5.400	5.950	24.	93.	10.	13.	30.	12.6
366	3.250	5.550	8.	90.	0.	30.	30.	12.6
367	3.650	5.800	12.	94.	13.	20.	30.	12.6
368	4.200	6.500	7.	92.	-20.	-5.	30.	12.6

GROUP SEVEN

APPENDIX I.

Source 3

N	RI	RT	SA
346	3.400	14.76	221.5
347	3.250	21.52	153.2
348	2.520	12.57	161.1
349	1.650	59.96	22.0
350	2.100	125.64	14.5
351	3.900	23.84	163.4
352	3.320	19.35	172.3
353	5.950	15.63	279.9
354	6.730	31.76	154.8
355	6.330	22.63	183.3
356	5.600	33.25	105.5
357	7.750	302.99	15.4
358	4.320	34.24	74.3
359	4.400	21.33	125.8
360	3.200	21.63	94.0
363	4.400	21.31	184.8
364	5.050	27.56	169.0
365	5.400	19.11	275.9
366	3.250	7.96	263.2
367	3.650	8.72	275.1
368	4.200	10.36	253.2

APPENDIX I.

Source 4

N	RL	R2	D	T	V1	V2	X	I
101	0.500	2.500	9.	94.	25000.	10000.	30.	10.2
102	1.840	3.630	14.	92.	1200.	1250.	30.	10.2
103	2.100	3.650	23.	85.	350.	-520.	30.	10.2
104	2.400	3.610	29.	73.	500.	130.	30.	9.8
105	2.870	3.940	27.	96.	170.	-400.	30.	9.8
106	3.550	4.720	21.	66.	310.	220.	30.	9.8
107	4.120	5.430	17.	96.	90.	-150.	30.	9.8
111	1.500	3.370	3.	104.	1250.	-850.	30.	10.1
112	1.830	3.230	18.	90.	1000.	1100.	30.	9.8
113	1.840	3.350	26.	95.	-1270.	-200.	30.	9.8
114	2.850	3.760	28.	87.	470.	-350.	30.	9.8
115	3.120	4.130	26.	88.	-370.	325.	30.	9.8
116	4.090	5.090	20.	81.	-145.	160.	0.	9.8
117	4.990	5.800	19.	81.	-150.	90.	30.	9.8
118	5.460	5.630	19.	98.	-60.	60.	30.	9.8
119	4.570	5.210	19.	90.	-20.	140.	30.	9.8
120	0.830	2.470	3.	98.	13050.	30000.	30.	9.5
121	5.250	3.320	2.	90.	152.	-44.	30.	9.5
122	6.370	4.450	0.	112.	1700.	2000.	30.	9.1
123	7.120	5.210	1.	87.	-720.	-1250.	30.	9.1
124	7.570	5.750	1.	73.	60.	100.	30.	9.1
125	4.430	2.550	0.	92.	800.	-30.	30.	9.
151	2.590	0.720	12.	90.	1100.	-1170.	30.	9.8
152	3.510	1.600	0.	90.	-570.	-2000.	30.	9.8
153	4.130	2.240	7.	90.	-190.	-1100.	30.	9.8
154	5.960	4.040	2.	135.	-420.	-130.	30.	9.9
155	6.690	4.750	2.	90.	-10.	-160.	30.	9.8
156	7.300	5.390	2.	90.	60.	-90.	30.	9.8
157	5.150	3.260	4.	90.	-450.	60.	30.	9.8
158	4.530	2.730	11.	90.	-750.	-6300.	30.	9.5
159	5.100	3.540	15.	90.	-5.	-220.	30.	9.5
160	4.340	2.910	20.	90.	-720.	-5.	30.	9.5
161	4.070	3.040	28.	90.	-72.	-62.	30.	9.1
162	4.376	3.630	26.	90.	-130.	-220.	30.	9.1
163	4.400	4.090	26.	90.	40.	-95.	30.	9.1
164	4.530	4.680	24.	90.	23.	-92.	30.	9.1

GROUP SEVEN

APPENDIX I.

Source 4

N	RI	RA	SA
101	0.500	140.78	3.0
102	1.840	162.30	7.9
103	2.100	83.84	18.5
104	2.400	95.82	20.3
105	2.870	127.75	18.7
106	3.550	171.18	16.2
107	4.120	126.80	23.9
111	1.500	79.81	13.0
112	1.480	83.86	12.8
113	1.840	127.61	10.9
114	2.580	137.13	15.3
115	3.120	190.74	13.8
116	4.090	186.60	17.9
117	4.990	261.70	16.7
118	5.460	155.96	35.1
119	4.570	170.70	24.1
120	0.580	272.88	1.7
121	3.320	68.40	30.1
122	4.450	2949.14	0.9
123	5.210	1894.33	1.6
124	5.750	186.85	17.6
125	2.550	178.97	9.0
151	0.720	19.23	29.7
152	1.600	143.44	7.7
153	2.240	168.69	8.7
154	4.040	466.92	5.2
155	4.750	155.59	17.9
156	5.890	186.40	18.1
157	3.260	171.57	11.7
158	2.730	1617.95	1.1
159	3.540	110.89	22.0
160	2.910	225.19	9.5
161	3.040	35.35	73.6
162	3.680	185.35	18.4
163	4.090	90.44	45.2
164	4.580	113.71	40.6

GROUP SEVEN

APPENDIX I.

Source 5

N	R1	R2	D	T	V1	V2	X	I
501	3.150	4.800	28.	122.	150.	45.	30.	12.6
502	4.100	5.650	23.	85.	40.	-45.	30.	12.6
503	5.150	6.250	23.	94.	20.	0.	30.	12.6
504	5.900	6.600	22.	86.	10.	0.	30.	12.6
505	4.000	5.800	19.	80.	20.	-80.	30.	12.6
506	4.550	6.600	14.	90.	20.	40.	30.	12.6
507	5.700	7.850	11.	90.	15.	-15.	30.	12.6
508	3.600	4.800	16.	90.	-105.	40.	30.	12.6
509	4.400	5.400	28.	86.	0.	35.	30.	12.6
510	2.500	4.000	37.	93.	190.	-55.	30.	12.6
511	1.900	2.700	62.	104.	-600.	-4000.	30.	11.2
512	2.350	2.650	60.	90.	800.	150.	30.	11.2
513	2.100	3.100	52.	90.	800.	90.	30.	11.2
514	4.300	5.850	22.	94.	-35.	200.	30.	11.2
515	5.250	6.500	22.	89.	160.	20.	30.	11.2
516	5.500	6.400	23.	92.	-80.	25.	30.	11.2
517	6.450	7.000	22.	88.	-70.	20.	30.	11.2
518	6.150	6.450	23.	93.	-175.	-50.	30.	11.2
519	6.650	6.650	22.	90.	25.	10.	30.	11.2
520	6.100	6.400	24.	90.	10.	-20.	30.	11.2
521	1.000	1.600	150.	90.	2100.	-1600.	30.	11.2
522	0.750	3.000	42.	90.	-2200.	-500.	30.	11.2
523	1.600	3.500	42.	90.	-900.	-500.	30.	11.2
524	2.150	4.150	31.	90.	-240.	-210.	30.	11.2
525	2.800	4.900	22.	90.	-270.	-120.	30.	11.2
526	3.250	5.500	14.	90.	-45.	530.	30.	11.
527	3.750	6.000	12.	90.	-165.	-17.	30.	11.
528	2.200	4.500	18.	90.	145.	480.	30.	11.2
529	2.150	4.600	5.	90.	-210.	-180.	30.	11.
530	1.750	4.200	3.	90.	-400.	280.	30.	11.2
531	4.500	5.200	29.	90.	12.	-20.	30.	12.6
532	4.250	4.700	31.	83.	50.	-25.	30.	12.6
533	4.100	4.100	35.	96.	60.	8.	30.	12.6
534	3.250	4.700	33.	88.	90.	-35.	30.	12.6
535	3.600	4.050	37.	88.	-75.	0.	30.	12.6
536	4.400	5.600	26.	80.	-105.	-40.	30.	12.6
537	5.300	6.350	23.	98.	-25.	-35.	30.	12.6
538	6.550	7.500	20.	90.	10.	-18.	30.	12.6
539	7.000	8.250	16.	104.	0.	-35.	30.	12.6
540	7.600	8.900	15.	110.	0.	10.	30.	12.6
541	6.650	9.000	80.	-20.	13.	30.	13.	0.0
542	7.300	7.400	20.	89.	0.	25.	30.	11.2
543	6.800	7.200	20.	89.	18.	-10.	30.	11.2
544	6.900	7.700	19.	113.	8.	-14.	30.	11.2
545	4.500	5.600	26.	109.	-20.	35.	30.	11.2

GROUP SEVEN

APPENDIX I.

Source 5

N	RI	RT	SA
501	3.150	52.93	47.6
502	4.100	31.77	101.5
503	5.150	19.25	234.3
504	5.900	14.67	382.0
505	4.000	40.55	71.4
506	4.550	27.89	109.7
507	5.700	23.27	158.4
508	3.600	49.97	51.6
509	4.400	21.81	184.6
510	2.500	27.92	77.1
511	1.900	329.47	6.0
512	2.350	92.20	26.5
513	2.100	82.64	25.0
514	4.300	129.16	26.0
515	5.250	178.52	24.9
516	5.500	109.11	46.2
517	6.450	149.73	42.2
518	6.150	334.39	18.4
519	6.650	58.37	113.9
520	6.100	38.34	159.8
521	1.000	36.55	31.8
522	0.750	24.84	26.3
523	1.600	57.48	23.6
524	2.150	35.18	48.2
525	2.800	61.11	33.4
526	3.250	157.59	13.9
527	3.750	69.94	35.2
528	2.200	58.40	27.0
529	2.150	30.49	48.3
530	1.750	33.85	36.5
531	4.500	15.71	277.3
532	4.250	34.37	123.8
533	4.100	28.63	143.2
534	3.950	45.32	84.7
535	3.600	26.89	135.3
536	4.400	66.27	57.7
537	5.300	47.85	98.4
538	6.550	38.20	155.1
539	7.000	80.15	71.0
540	7.600	29.10	209.9
541	6.650		
542	7.400	73.62	100.2
543	6.800	52.07	129.3
544	6.900	35.79	178.6
545	4.800	33.34	135.4

GROUP SEVEN

APPENDIX I.

Source 5

N	R1	R2	D	T	V1	V2	X	I
546	5.700	6.000	24.	118.	-40.	32.	30.	11.2
547	5.800	6.600	21.	92.	25.	0.	30.	11.2
548	5.500	6.100	24.	93.	23.	-12.	30.	11.2
549	4.700	5.100	29.	89.	60.	-225.	30.	11.2
550	4.400	5.900	22.	79.	125.	80.	30.	11.2
551	4.900	6.400	20.	105.	-22.	-30.	30.	11.2
552	5.600	7.000	19.	84.	-22.	0.	30.	11.2
553	2.900	4.600	30.	103.	210.	-90.	30.	11.2
554	2.100	3.800	38.	88.	-15.	400.	30.	11.2
555	2.300	4.100	36.	95.	-190.	-45.	30.	11.2
556	1.400	3.200	49.	86.	620.	-130.	30.	11.2
557	3.600	6.100	7.	95.	-80.	125.	30.	11.2
555	4.000	6.500	2.	85.	-60.	20.	30.	11.2
559	4.800	7.300	1.	87.	-130.	30.	30.	11.2
560	5.200	7.700	3.	90.	-43.	70.	30.	11.2
561	1.300	4.200	11.	80.	-370.	-350.	30.	11.2
562	1.000	3.000	53.	90.	3100.	1050.	30.	11.2
563	0.850	3.100	40.	90.	3400.	2250.	30.	11.2
564	1.900	3.800	35.	90.	370.	170.	30.	11.2
565	6.300	8.100	16.	95.	15.	0.	30.	11.2
567	2.600	4.800	19.	89.	37.	-162.	30.	11.
568	3.200	3.800	40.	90.	410.	140.	30.	11.2
569	3.200	4.900	28.	93.	-95.	285.	30.	11.2
570	5.300	5.800	26.	111.	85.	-95.	30.	11.2
571	4.900	5.000	29.	90.	-190.	285.	30.	11.2
572	5.700	8.200	4.	85.	-27.	25.	30.	11.2
573	6.000	8.400	7.	100.	40.	40.	30.	11.2
574	6.100	8.600	1.	90.	30.	25.	30.	11.2
575	5.400	7.900	0.	96.	100.	0.	30.	11.2
576	4.700	7.200	4.	93.	0.	-140.	30.	11.2
577	4.500	6.800	9.	91.	65.	-70.	30.	11.2
578	3.250	5.700	3.	85.	-280.	400.	30.	11.2
579	3.250	5.700	3.	85.	-280.	400.	30.	11.2

GROUP SEVEN

APPENDIX I.

Source 5

N	RI	RT	SA
546	5.700	63.91	89.5
547	5.800	40.06	133.5
548	5.500	34.38	155.3
549	4.700	199.40	23.6
550	4.400	94.31	36.8
551	4.900	39.51	96.7
552	5.600	29.07	153.8
553	2.900	49.26	47.5
554	2.100	42.28	41.8
555	2.800	43.02	57.5
556	1.400	26.64	46.6
557	3.600	52.88	43.7
558	4.000	31.36	79.1
559	4.800	102.56	28.3
560	5.200	76.27	41.0
561	1.800	34.67	37.0
562	1.000	65.22	13.8
563	0.850	53.27	12.5
564	1.900	33.97	45.4
565	6.800	34.58	157.3
567	2.600	28.94	63.9
568	3.200	128.56	25.0
569	3.200	86.64	29.5
570	5.300	130.21	40.3
571	4.900	313.17	15.8
572	5.700	45.07	75.9
573	6.000	84.01	43.6
574	6.100	54.56	65.5
575	5.400	102.83	31.2
576	4.700	100.53	28.6
577	4.500	62.80	45.3
578	3.000	46.2	
579	3.250	149.19	13.9

GROUP SEVEN

APPENDIX I.

Source 6

N	R1	R2	D	T	V1	V2	I	X
601	0.900	3.300	0.	90.	3200.	-650.	13.	30.0
602	1.400	3.800	11.	90.	800.	120.	13.	30.0
603	2.400	4.350	24.	90.	95.	-100.	13.	30.0
604	2.200	4.550	13.	90.	105.	50.	13.	30.0
605	3.350	4.950	26.	90.	60.	-40.	13.	30.0
606	3.800	5.150	26.	90.	22.	50.	13.	30.0
607	3.600	4.600	32.	90.	70.	-55.	13.	30.0
608	3.650	4.250	34.	88.	90.	70.	13.	30.0
609	9.200	4.250	33.	90.	30.	-90.	13.	30.0
610	4.200	4.500	32.	118.	62.	-55.	13.	30.0
611	5.000	7.300	5.	89.	-40.	20.	13.	30.0
612	5.050	7.300	7.	90.	-12.	-17.	13.	30.0
613	5.200	7.250	12.	90.	-10.	25.	13.	30.0
614	4.800	6.700	15.	90.	55.	35.	13.	30.0
615	4.250	6.100	17.	105.	-125.	-80.	13.	30.0
616	4.150	5.700	22.	90.	-33.	90.	13.	30.0
617	3.800	5.250	24.	90.	30.	-150.	13.	30.0
618	3.500	4.800	26.	87.	-100.	-480.	13.	30.0
619	3.150	4.950	23.	90.	140.	-67.	13.	30.0
620	2.750	4.800	26.	90.	150.	-250.	13.	30.0
621	3.350	4.600	32.	90.	100.	-15.	13.	30.0
622	3.400	3.700	40.	90.	140.	100.	13.	30.0
623	3.200	3.500	42.	92.	240.	30.	13.	30.0
624	4.500	5.300	26.	90.	60.	0.	13.	30.0
625	4.750	4.950	28.	90.	10.	-50.	13.	30.0
626	5.050	5.250	27.	90.	40.	5.	13.	30.0
627	5.800	6.100	23.	90.	0.	-25.	13.	30.0
628	6.550	7.200	19.	95.	25.	-10.	13.	30.0
629	6.900	7.800	17.	96.	0.	-30.	13.	30.0
630	6.900	8.000	17.	100.	0.	-15.	13.	30.0
631	2.550	4.700	17.	90.	120.	-750.	13.	30.0
632	2.700	5.000	9.	90.	-50.	-700.	13.	30.0
633	3.050	5.300	9.	92.	-165.	-65.	13.	30.0
634	3.700	5.900	9.	90.	-40.	190.	13.	30.0
635	4.200	6.300	10.	90.	-50.	28.	13.	30.0
636	4.350	6.650	9.	90.	-70.	-40.	13.	30.0
637	2.300	3.400	43.	80.	370.	520.	13.	30.0
638	3.050	3.400	45.	90.	-200.	-250.	13.	30.0
639	2.400	3.700	40.	95.	310.	210.	13.	30.0
640	3.340	4.250	35.	90.	80.	-80.	13.	30.0
641	6.100	7.150	19.	90.	0.	-25.	13.	30.0
642	5.550	6.500	20.	84.	0.	35.	13.	30.0
643	5.400	6.050	24.	90.	35.	0.	13.	30.0
644	6.100	6.200	23.	90.	0.	0.	13.	30.0
645	4.200	5.200	16.	90.	-90.	0.	13.	30.0

GROUP SEVEN

APPENDIX I.

Source 6

N	RI	RT	SA
601	0.900	47.50	14.9
602	1.400	30.37	34.1
603	2.400	18.05	98.8
604	2.200	12.07	127.1
605	3.350	21.67	122.2
606	3.800	23.24	135.4
607	3.600	33.13	100.0
608	3.650	43.81	82.3
609	4.250	34.37	98.7
610	4.200	38.00	111.8
611	5.000	35.06	86.3
612	5.050	16.67	186.1
613	5.200	23.83	143.2
614	4.800	47.81	69.2
615	4.250	92.28	32.5
616	4.150	50.31	64.1
617	3.800	65.22	46.4
618	3.500	172.95	16.6
619	3.150	39.61	59.4
620	2.750	50.99	40.9
621	3.850	45.34	81.8
622	3.400	51.04	68.0
623	3.200	61.28	53.4
624	4.500	42.72	98.2
625	4.750	40.67	117.9
626	5.050	37.57	135.7
627	5.800	35.79	162.4
628	6.550	54.06	114.6
629	6.900	70.21	86.9
630	6.900	33.35	175.7
631	2.550	113.45	15.7
632	2.700	119.11	15.1
633	3.050	41.07	48.5
634	3.700	71.89	32.9
635	4.200	29.63	90.5
636	4.350	43.55	63.3
637	2.800	112.86	25.0
638	3.050	69.33	45.1
639	2.400	51.20	41.9
640	3.340	34.58	91.2
641	6.100	39.50	133.4
642	5.550	44.89	108.5
643	5.400	40.12	129.5
644	6.100		
645	4.200	63.75	50.2

GROUP SEVEN

APPENDIX I.

Source 6

N	R1	R2	D	T	V1	V2	I	X
646	3.000	4.400	31.	90.	160.	-120.	13.	30.0
647	4.550	6.250	18.	90.	-40.	0.	13.	30.0
648	4.800	6.200	20.	88.	-30.	50.	13.	30.0
649	5.200	6.250	20.	90.	50.	0.	13.	30.0
650	5.450	6.350	22.	90.	30.	-30.	13.	30.0
651	2.350	2.350	60.	95.	-400.	-300.	13.	30.0
652	2.050	2.600	61.	90.	175.	-330.	13.	30.0
653	1.700	3.200	46.	90.	-1150.	-1300.	13.	30.0
654	1.700	3.750	26.	95.	-240.	-610.	13.	30.0
655	2.000	4.300	7.	95.	280.	375.	13.	30.0
656	2.900	5.200	3.	90.	1150.	-1500.	13.	30.0
657	1.950	4.300	2.	90.	1150.	820.	13.	30.0
658	1.850	4.100	11.	90.	200.	380.	13.	30.0
659	3.550	5.850	3.	95.	270.	400.	13.	30.0
660	4.200	6.550	0.	90.	-120.	-15.	13.	30.0
661	4.850	7.200	0.	90.	0.	50.	13.	30.0
662	1.300	3.600	5.	92.	675.	500.	13.	30.0
663	0.350	2.750	2.	95.	3700.	1100.	13.	30.0
664	0.600	2.850	33.	90.	-200.	1100.	13.	30.0
665	1.500	3.550	29.	90.	-180.	-400.	13.	30.0
666	2.450	4.200	29.	105.	-380.	0.	13.	30.0
667	3.100	4.700	25.	92.	-215.	210.	13.	30.0
668	3.800	5.450	28.	90.	-250.	-125.	13.	30.0
669	4.650	6.450	16.	90.	-200.	180.	13.	30.0
670	6.000	7.800	12.	90.	-110.	-35.	13.	30.0
671	6.750	8.500	10.	90.	-75.	0.	13.	30.0
672	5.750	7.700	2.	90.	220.	-190.	13.	30.0
673	3.950	4.150	33.	90.	75.	-53.	13.	30.0
674	3.550	3.850	38.	95.	100.	-200.	13.	30.0
675	3.000	4.000	36.	95.	300.	135.	13.	30.0
676	3.750	4.900	27.	90.	50.	-180.	13.	30.0
677	4.000	5.300	25.	72.	-160.	60.	13.	30.0
678	4.700	6.200	19.	90.	-190.	-110.	13.	30.0
679	1.300	1.450	119.	85.	-1500.	675.	13.	30.0
680	1.250	1.800	103.	90.	870.	-1440.	13.	30.0
681	0.900	2.300	85.	95.	1575.	1350.	13.	30.0
682	0.850	2.700	58.	90.	510.	-1800.	13.	30.0
683	2.000	4.350	5.	95.	-80.	-150.	13.	30.0
684	2.200	4.500	8.	85.	-80.	-210.	13.	30.0
685	2.700	4.750	19.	90.	80.	-240.	13.	30.0
686	2.840	3.400	45.	91.	-220.	60.	13.	30.0
687	1.600	2.750	60.	109.	-600.	550.	13.	30.0
688	2.700	3.700	40.	83.	130.	130.	13.	30.0

GROUP SEVEN

APPENDIX I.

Source 6

N	RI	RT	SA
646	3.000	46.28	54.4
647	4.550	26.56	124.9
648	4.800	47.08	80.2
649	5.200	53.25	82.9
650	5.450	49.94	98.9
651	2.350	47.94	49.0
652	2.050	29.53	72.6
653	1.700	100.40	15.1
654	1.700	39.60	32.7
655	2.000	41.30	33.4
656	2.900	383.49	4.9
657	1.950	112.15	12.0
658	1.850	30.44	42.8
659	3.550	166.45	13.3
660	4.200	60.17	42.5
661	4.850	35.77	81.0
662	1.300	27.53	34.8
663	0.350	8.20	37.9
664	0.600	6.93	75.7
665	1.500	19.31	60.7
666	2.450	54.34	35.3
667	3.100	74.65	32.1
668	3.800	109.02	28.6
669	4.650	186.02	17.6
670	6.000	157.24	25.6
671	6.750	143.96	30.6
672	5.750	360.84	9.2
673	3.950	43.51	92.0
674	3.550	73.45	49.2
675	3.000	79.92	34.8
676	3.750	79.90	40.4
677	4.000	97.15	34.2
678	4.700	163.15	21.9
679	1.300	30.79	44.3
680	1.250	36.36	38.2
681	0.900	29.22	32.1
682	0.850	23.63	33.1
683	2.000	14.85	92.7
684	2.200	23.03	65.1
685	2.700	43.66	43.8
686	2.840	43.11	66.9
687	1.600	34.23	46.1
688	2.700	30.73	82.7

GROUP SEVEN

APPENDIX I.

Source 7

N	R1	R2	D	T	V1	V2	I	X
801	0.900	2.550	35.	90.	2030.	-710.	19.	30.0
802	1.700	2.930	39.	90.	320.	-35.	19.	30.0
803	2.460	3.340	36.	90.	130.	-110.	19.	30.0
804	3.250	3.830	31.	90.	95.	-135.	19.	30.0
805	3.850	4.230	27.	90.	132.	-40.	19.	30.0
806	4.170	4.170	27.	85.	80.	20.	19.	30.0
807	3.900	4.300	26.	90.	90.	75.	19.	30.0
808	4.460	5.130	22.	90.	-50.	0.	19.	30.0
809	4.560	5.530	19.	90.	-35.	80.	19.	30.0
810	2.000	3.900	2.	90.	200.	145.	19.	30.0
811	1.200	2.870	24.	92.	-600.	-1200.	19.	30.0
812	1.800	3.600	16.	88.	-160.	-160.	19.	30.0
813	1.360	3.200	4.	82.	-600.	-320.	19.	30.0
814	3.050	4.930	4.	82.	-55.	-50.	19.	30.0
815	1.700	3.150	31.	93.	-400.	-30.	19.	30.0
816	2.950	4.100	26.	87.	80.	250.	19.	30.0
817	3.670	4.800	22.	86.	-125.	85.	19.	30.0
818	3.950	4.620	21.	94.	-105.	-95.	19.	30.0
819	4.850	5.400	21.	92.	-45.	-30.	19.	30.0
820	5.550	6.770	13.	83.	60.	95.	19.	30.0
821	2.700	4.580	4.	100.	130.	-55.	19.	30.0
822	3.350	5.200	7.	90.	-160.	55.	19.	30.0
823	4.550	6.340	12.	90.	65.	5.	19.	30.0
824	5.200	6.900	10.	90.	70.	30.	19.	30.0
825	4.850	6.040	16.	90.	5.	40.	19.	30.0
826	5.570	6.800	14.	90.	0.	40.	19.	30.0
827	5.920	7.380	11.	90.	25.	40.	19.	30.0
828	4.050	5.830	8.	90.	-80.	0.	19.	30.0
829	4.040	5.720	4.	90.	0.	135.	19.	30.0
830	4.540	6.440	1.	90.	0.	85.	19.	30.0
831	6.030	6.820	15.	94.	-20.	110.	19.	30.0
832	5.860	6.430	17.	86.	25.	-30.	19.	30.0
833	5.700	6.030	18.	98.	10.	30.	19.	30.0
834	5.160	5.250	21.	98.	-20.	0.	19.	30.0
835	4.580	4.880	23.	95.	-40.	0.	19.	30.0
836	3.820	5.160	18.	90.	90.	0.	19.	30.0
837	3.340	4.900	15.	93.	-150.	20.	19.	30.0
838	3.670	5.430	9.	93.	60.	100.	19.	30.0
839	2.640	4.400	12.	95.	-95.	110.	19.	30.0
840	4.400	5.960	12.	90.	-30.	-60.	19.	30.0
841	5.200	7.230	0.	90.	80.	10.	19.	30.0
842	5.550	7.450	1.	90.	10.	55.	19.	30.0
843	5.560	6.930	4.	90.	-90.	-40.	19.	30.0
844	4.350	6.200	6.	90.	-95.	-80.	19.	30.0
845	3.760	5.630	5.	90.	-100.	-45.	19.	30.0

GROUP SEVEN

APPENDIX I.

Source 7

N	RI	RT	SA
801	0.900	21.33	34.6
802	1.700	13.35	109.2
803	2.460	17.63	128.0
804	3.250	36.14	86.9
805	3.850	49.26	77.5
806	4.170	33.31	125.2
807	3.900	44.13	87.1
808	4.460	26.63	154.0
809	4.560	47.70	79.0
810	2.000	14.75	89.7
811	1.200	25.58	35.7
812	1.800	10.40	122.0
813	1.360	16.04	59.7
814	3.050	11.53	164.7
815	1.700	16.78	80.1
816	2.950	42.72	56.3
817	3.670	45.80	64.4
818	3.950	61.26	57.4
819	4.850	37.48	122.5
820	5.550	96.13	41.8
821	2.700	16.49	103.7
822	3.350	35.47	59.0
823	4.550	29.29	102.0
824	5.200	50.20	66.3
825	4.850	24.90	147.4
826	5.570	35.54	116.1
827	5.920	46.86	85.2
828	4.050	27.47	91.5
829	4.040	48.21	49.8
830	4.540	38.36	69.5
831	6.030	139.77	36.8
832	5.860	48.24	112.9
833	5.700	37.87	148.0
834	5.160	16.49	314.6
835	4.580	23.66	192.8
836	3.820	28.50	98.7
837	3.340	32.80	69.4
838	3.670	31.98	72.3
839	2.640	16.44	106.2
840	4.400	29.75	97.7
841	5.200	49.74	60.8
842	5.550	42.59	74.8
843	5.560	92.91	34.4
844	4.350	50.40	52.3
845	3.760	30.63	74.9

GROUP SEVEN

APPENDIX I.

Source 7

N	R1	R2	D	T	V1	V2	I	X
846	3.300	5.150	5.	90.	-120.	15.	19.	30.0
847	2.950	4.840	1.	90.	-110.	-145.	19.	30.0
848	2.120	4.000	6.	90.	-155.	190.	19.	30.0
849	2.100	3.860	14.	90.	205.	-220.	19.	30.0
850	2.500	4.000	21.	90.	0.	-350.	19.	30.0
851	4.900	5.350	21.	72.	-50.	0.	19.	30.0
852	4.800	5.600	19.	89.	50.	-30.	19.	30.0
853	4.400	5.600	17.	90.	-70.	-30.	19.	30.0
854	5.000	6.750	8.	93.	0.	-40.	19.	30.0
855	4.600	6.500	1.	90.	-10.	0.	19.	30.0
856	3.250	5.700	8.	88.	-10.	55.	19.	30.0
857	4.000	5.800	6.	93.	35.	-45.	19.	30.0
858	4.550	6.450	3.	100.	-55.	0.	19.	30.0
859	5.150	6.950	5.	97.	-22.	-17.	19.	30.0
860	4.650	6.300	10.	90.	-30.	0.	19.	30.0
861	3.100	4.660	17.	90.	0.	260.	19.	30.0
862	3.600	5.030	13.	98.	190.	-120.	19.	30.0
863	3.330	4.770	19.	83.	45.	-270.	19.	30.0
864	4.100	5.720	11.	103.	75.	-190.	19.	30.0
865	4.750	6.500	8.	95.	130.	-380.	19.	30.0
866	5.680	7.500	5.	90.	-90.	-280.	19.	30.0
867	5.410	7.130	8.	90.	0.	-60.	19.	30.0
868	5.030	6.630	11.	90.	25.	-25.	19.	30.0
869	5.070	6.420	14.	103.	95.	-35.	19.	30.0
870	4.920	6.100	16.	98.	40.	-65.	19.	30.0
871	5.600	7.250	9.	90.	0.	-20.	19.	30.0
872	5.500	7.050	11.	90.	-40.	0.	19.	30.0
873	6.200	7.400	13.	90.	30.	27.	19.	30.0
874	5.550	6.850	13.	93.	-20.	-25.	19.	30.0
875	4.800	6.300	14.	105.	0.	-35.	19.	30.0
876	4.000	5.400	16.	90.	0.	70.	19.	30.0
877	3.150	4.500	21.	90.	40.	70.	19.	30.0
878	2.550	4.000	23.	90.	80.	-80.	19.	30.0
879	1.700	3.300	26.	90.	120.	180.	19.	30.0
880	1.000	2.650	35.	90.	130.	70.	19.	30.0
881	1.150	2.500	50.	90.	1420.	-800.	19.	30.0
882	0.500	1.900	82.	90.	2700.	31400.	19.	30.0
883	1.100	1.200	114.	90.	-1700.	1100.	19.	38.0
883	1.100	1.200	114.	90.	-1700.	1100.	19.	30.0
884	1.900	1.000	57.	90.	500.	-400.	19.	30.0
885	1.350	1.950	69.	105.	-900.	-1900.	19.	30.0
886	1.350	2.250	55.	90.	-750.	150.	19.	30.0
887	0.800	2.700	0.	90.	2200.	300.	19.	30.0
888	1.050	2.900	15.	90.	1000.	750.	19.	30.0
889	1.500	3.050	29.	90.	950.	260.	19.	30.0
890	2.100	3.300	32.	95.	900.	-2600.	19.	30.0

GROUP SEVEN

APPENDIX I.

Source 7

N	RI	RT	SA
846	3.300	24.52	83.2
847	2.950	27.72	66.1
848	2.120	16.86	83.0
849	2.100	20.42	70.3
850	2.500	37.05	49.0
851	4.900	37.60	126.1
852	4.800	38.55	108.3
853	4.400	36.27	91.7
854	5.000	23.83	129.5
855	4.600	4.67	577.5
856	3.950	18.31	133.9
857	4.000	18.55	131.3
858	4.550	25.27	106.4
859	5.150	18.97	160.7
860	4.650	15.11	196.2
861	3.100	46.58	46.4
862	3.600	59.03	40.7
863	3.330	61.18	39.6
864	4.100	70.74	37.4
865	4.750	204.58	14.3
866	5.680	242.07	13.8
867	5.410	44.25	75.5
868	5.080	22.97	145.1
869	5.070	64.39	56.2
870	4.920	46.39	80.7
871	5.600	16.41	215.5
872	5.500	31.83	114.4
873	6.200	48.34	95.5
874	5.550	28.61	138.6
875	4.800	20.04	166.6
876	4.000	24.88	114.3
877	3.150	15.44	152.9
878	2.550	12.57	151.4
879	1.700	8.93	143.9
880	1.000	1.83	445.4
881	1.150	27.06	38.1
882	0.500	87.48	5.7
883	1.100	13.82	82.8
883	1.100	17.51	65.4
884	1.900	25.62	71.0
885	1.350	50.82	28.0
886	1.850	35.00	54.8
887	0.800	17.16	36.0
888	1.050	17.35	45.5
889	1.500	30.61	38.0
890	2.100	189.18	9.2

GROUP SEVEN

APPENDIX I

Source 7

N	R1	R2	D	T	V1	V2	I	X
891	3.950	5.100	19.	102.	-180.	-45.	19.	30.0
892	3.300	4.700	19.	100.	-120.	55.	19.	30.0
893	3.700	5.300	14.	86.	-100.	-30.	19.	30.0
894	2.300	3.750	25.	95.	-210.	-125.	19.	30.0
895	0.550	2.450	6.	90.	5500.	14200.	19.	30.0
896	0.700	1.200	173.	90.	-3200.	-1150.	19.	30.0
897	0.970	1.650	92.	80.	650.	-700.	19.	30.0
898	1.680	1.700	71.	90.	-760.	-50.	19.0	
899	0.900	1.930	77.	100.	-2300.	300.	19.	30.0
900	2.150	2.250	52.	83.	-280.	750.	19.	30.0
901	3.650	4.250	27.	110.	0.	-70.	19.	30.0
902	3.250	3.700	30.	87.	30.	-85.	19.	30.0
903	3.150	3.350	34.	117.	110.	-170.	19.	30.0
504	3.500	3.800	30.	91.	105.	-40.	19.	30.0
905	4.000	4.600	25.	93.	110.	135.	19.	30.0
906	4.750	5.300	21.	90.	12.	80.	19.	30.0
907	5.000	5.600	20.	97.	32.	-7.	19.	30.0
908	5.500	6.250	18.	90.	-15.	35.	19.	30.0
909	2.550	3.400	35.	90.	850.	-1350.	19.	30.0
910	4.150	4.650	25.	86.	-65.	35.	19.	30.0
911	4.800	5.700	19.	92.	-70.	-35.	19.	30.0
912	4.500	5.100	21.	99.	20.	55.	19.	30.0
913	4.500	4.700	21.	100.	40.	5.	19.	30.0
914	5.300	5.550	20.	88.	32.	50.	19.	30.0
915	5.800	5.950	19.	100.	-10.	-75.	19.	30.0
916	6.700	6.700	17.	116.	50.	-20.	19.	30.0
917	6.350	6.450	17.	100.	-40.	50.	19.	30.0
918	4.500	4.650	24.	95.	-75.	-110.	19.	30.0
919	5.100	5.100	22.	90.	90.	155.	19.	30.0
920	5.750	5.900	19.	83.	110.	95.	19.	30.0
921	2.500	2.620	44.	92.	-65.	600.	19.	30.0
922	2.600	2.940	40.	80.	-190.	0.	19.	30.0
923	2.420	3.090	38.	80.	-300.	-50.	19.	30.0
924	2.420	3.530	32.	80.	100.	90.	19.	30.0
925	3.400	4.950	16.	90.	-310.	90.	19.	30.0
926	3.060	4.200	26.	106.	-21.	90.	19.	30.0
927	5.200	6.300	16.	87.	25.	55.	19.	30.0
928	5.630	6.770	15.	90.	-20.	40.	19.	30.0
929	6.350	7.150	15.	75.	17.	25.	19.	30.0
930	6.740	7.700	13.	90.	7.	-23.	19.	30.0
931	6.150	7.200	14.	92.	27.	0.	19.	30.0

GROUP SEVEN

APPENDIX I.

Source 7

N	RI	RT	SA
891	3.950	71.89	42.5
892	3.300	26.91	89.4
893	3.700	28.65	87.0
894	2.300	21.86	79.8
895	0.550	53.38	8.4
896	0.700	13.71	60.3
897	0.970	10.21	104.6
898	1.680	11.39	148.3
899	0.900	21.09	43.9
900	2.150	50.82	43.1
901	3.650	22.82	151.9
902	3.250	21.03	151.9
903	3.150	33.92	94.2
904	3.500	30.22	116.4
905	4.000	70.25	53.8
906	4.750	52.78	85.0
907	5.000	23.94	194.5
908	5.500	35.73	137.1
909	2.550	182.28	12.9
910	4.150	33.17	121.1
911	4.800	50.07	81.3
912	4.500	35.51	117.4
913	4.500	26.01	173.2
914	5.300	52.74	100.3
915	5.800	89.50	65.1
916	6.700	83.87	79.9
917	6.350	90.23	70.6
918	4.500	76.12	59.5
919	5.100	134.67	37.9
920	5.750	153.73	37.5
921	2.500	57.61	44.2
922	2.600	22.39	118.0
923	2.420	30.28	76.9
924	2.420	12.31	167.3
925	3.400	73.26	32.1
926	3.060	16.25	154.7
927	5.200	44.95	90.4
928	5.630	41.48	104.9
929	6.350	38.64	141.5
930	6.740	39.32	137.4
931	6.150	33.01	146.4

GROUP SEVEN

APPENDIX II : PROCESSING AND INTERPRETATION
OF TIME-DOMAIN EM SOUNDINGS

In the time-domain electromagnetic sounding technique, as it was used in the Valles Caldera electrical survey, an electromagnetic signal is generated by passing a step-wave of current through a grounded length of wire. The magnetic field from this current is detected at a receiver site with a multi-turn loop of wire laid on the ground. The voltage induced in this coil of wire by the electromagnetic field incident at a receiver location was recorded on an analog recorder.

The same source lines used in the dipole mapping surveys were used for the time-domain electromagnetic soundings; the locations are indicated on Figure 1. Receiver locations were selected in areas of interest several kilometers away from a dipole source, generally along the equatorial axis of the source. The induction coil used as a receiver consisted of a 1000-foot length of 26-conductor cable, laid on the ground in the form of a square and connected so that the 26 conductors were in series and formed a continuous loop. The voltage generated in this loop was filtered to attenuate high frequencies (above 25 Hz) and then recorded on an analog oscillograph. A typical oscillograph record is shown in Figure 24.

The observed voltages, such as shown in this Figure, must be subjected to extensive data reduction procedures before they may be evaluated in terms of an earth conductivity structure. The transient voltage as recorded is distorted to some extent by the use of the low-pass filter, with the distortion being most severe in the early part of the signal. Also, noise added to the recorded signals makes recognition of the signals with the desired accuracy difficult. The first stage in reduction of the field observations consisted of efforts to reduce these problems. This initial reduction of the data consisted of the following steps:

1. Use of synchronous stacking to reduce the level of random noise in cases where the signal to noise ratio was low, or selection of the best signal in cases where the signal to noise ratio was high;
2. deconvolution, to minimize the effect of distortion in the recording equipment;
3. smoothing with an exponentially time-varying filter, to further reduce the uncorrelated noise; and
4. conversion to values of apparent resistivity, for

SANBORN *Recording Permapaper*

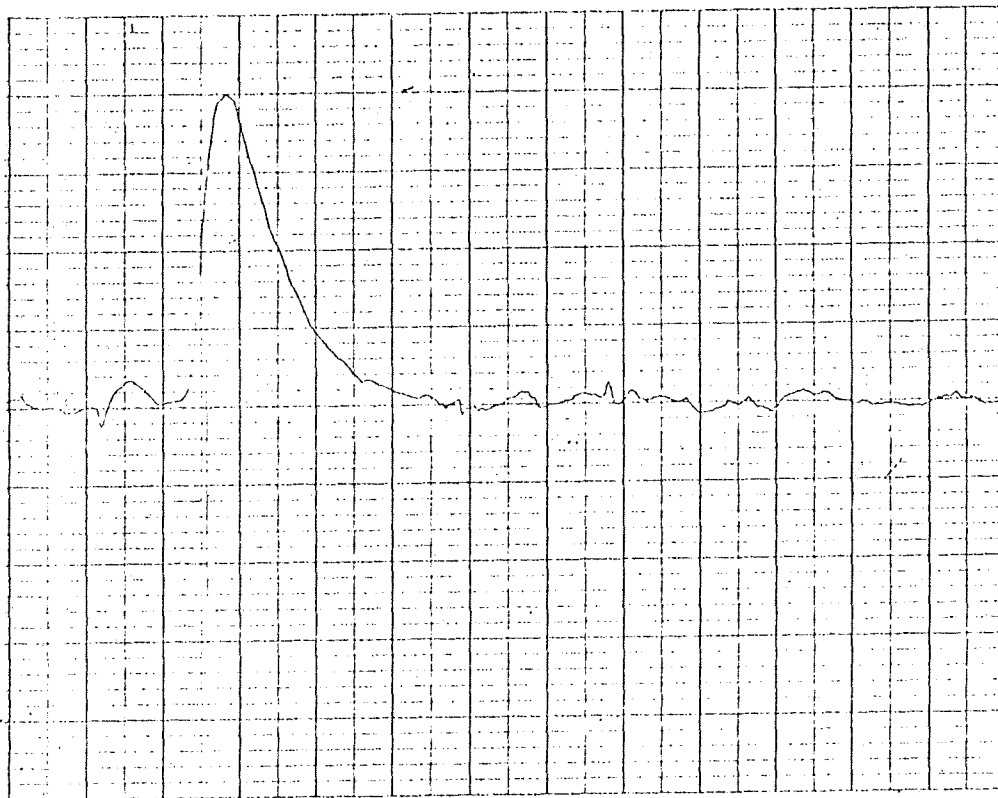

Figure 24. Example of the voltage recorded as an electromagnetic sounding. The vertical scale is 5 microvolts per division and the horizontal scale is 0.1 second per division. This record is part of sounding 605. The distance from source 6 was 4350 meters.

GROUP SEVEN

comparison with theoretical models.

Synchronous stacking or signal selection: Signals from 5 to 10 transmissions were recorded at each receiving station. This multiple recording permitted the selection of a signal with a minimum amount of added random noise, which was done in cases in which the signal level was much higher than the random noise level, or synchronous addition of several signals to reduce the apparent noise level, which was done in cases in which the noise level was significant. The analog records were digitized on a semi-automatic digitizer at an interval of 0.04 seconds. For those records with which synchronous addition was used, a statistical test was applied to each data point to see if it lay within a reasonable distance of the average for the group of signals being added. If not, that data point would not be included in the synchronous stacking. With the stacking of a number, n , of signals the random noise level should be reduced by a factor $(n-1)^{1/2}$, for large n . With the small numbers of signals added synchronously in these measurements, the relative noise reduction was twofold to threefold.

Deconvolution: After stacking, the effect of the low-pass filter was partially removed by deconvolution. To accomplish this, the transfer function of the recording system was computed from a record of the response to a step input voltage. The Fourier transform of each data set was computed and divided by the step-response spectrum. The resulting compensated spectrum was then transformed back to the time domain.

Smoothing: Deconvolution has the effect of enhancing the high-frequency components in the recorded signal. The stacking process results in a random scatter of successive points on the stacked signals which has a dominant frequency equal to the Nyquist frequency for the data sampling rate. As a consequence, the deconvolved data are much more "noisy" in appearance than the original stacked data. Linear filtering cannot be applied because such a procedure would merely reduce the efficiency of deconvolution. A non-linear filtering process was used to smooth the deconvolved signals.

This non-linear filtering method was based on the shape-invariant property of transient electromagnetic sounding curves when they are plotted to logarithmic coordinates. As will be described later, interpretation is accomplished by a graphical comparison of field data with theoretical curves when both are plotted to logarithmic coordinates. When the linearly sampled field data are plotted to logarithmic coordinates, the early part of a signal appears to be sparsely sampled while the late part appears to be densely sampled. Because the noise that persists after signals have been stacked has a half-period equal to the distance between two successive data points, the noise appears to increase in frequency for progressively later

parts of the signal, when data are presented in the logarithmic format. Moreover, the signal to noise ratio is higher in the early part of the signal than in the later part. This variation in signal to noise ratio as the apparent frequency varies provides a basis for separating the signal from noise during the late part of the signal without undoing the effect of deconvolution on the early part. This is accomplished by applying a linear smoothing filter in the logarithmic domain, which is equivalent to applying a logarithmically time-compressed filter in the original linear-time domain.

Conversion to apparent resistivity: The final step in data reduction was the conversion of the measured voltages to values of apparent resistivity. Because there is no unique relationship between observed voltage and apparent resistivity for induction-field electromagnetic soundings, a value for apparent resistivity can be computed only by assuming some asymptotic condition. An expression given by Vanyan (1967), valid only for the early part of a signal, was used in converted the observed signals to early-time apparent resistivity curves. This expression is:

$$\rho_a = \frac{2\pi R^4}{3AM \cos \theta} V(t)$$

where M is the moment of the source (product of current and wire length), A is the area of the receiving loop, θ is the angle between the equatorial axis of the source line and the radius vector from the middle of the source line to the receiving station, R is the distance between the center of the source wire and the center of the receiver loop, and V(t) is the recorded voltage as a function of time, t.

The initial data reduction described above is intended primarily to convert the observed data to a standardized form for interpretation. For the early part of the signals, the apparent resistivities as computed with the formula above will have some loose association with the actual resistivity in the earth, but for the late part of the signal, the apparent resistivities may be much different than any resistivity in the earth. However, despite the fact that these values have no meaning in terms of actual resistivity distributions in the earth, the use of the formula is convenient for comparing the field data with theoretical curves presented in the same normalized fashion.

Procedures for interpreting electromagnetic sounding curves are not yet as fully developed as procedures for interpreting DC sounding curves. In principle, field data are interpreted by comparison with theoretical curves computed for specific models of earth electrical structure. The theoretical curves used in interpreting the data obtained in the

were computed for a sequence of two or three horizontal layers (Frischknecht, 1967) and transformed to a time-domain presentation by Silva (1969). A representative set of theoretical curves for a sequence of two layers is shown in Figure 25. In these curves, the ratio of resistivities between the two layers is fixed, while the ratio of separation between source and receiver to the thickness of the upper layer varies from curve to curve. As may be seen, and as would be expected, the early-time apparent resistivity values approach the actual resistivity in the surface layer. If the thickness of the surface layer is small compared to the separation between source and receiver, the apparent resistivity value begins to depart from the value for the surface layer at later times and approach the value for the second layer. However, at still later times, the apparent resistivity values are grossly affected by the assumptions made in development of the computational formula, and rapidly drop to low values which have no real significance.

It has been the experience of Group Seven, Inc. that graphical curve comparison between observed electromagnetic sounding curves and theoretically-computed curves is not an effective means of interpretation because the character or shape of the theoretical curves varies so little from case to case. In matching a field curve with a model curve, not only must the shape of the field curve correspond to the shape of the model curve with which it is matched, but the horizontal and vertical positions of the coordinate axes on the two plots must provide the same value for first-layer conductivity when the curves are matched. To accomplish this, a technique has been devised to assist in arriving at a self-consistent interpretation. The technique consists of matching a field curve with the early-time theoretical curve for a uniform halfspace, with the emphasis on matching being placed on the portion of the curve where the transition from early-time to late-time behavior takes place. The match provides two values for first-layer conductivity -- one from the relative positions of the vertical scales on the two plots when the curves are matched, and one from the relative positions of the horizontal scales. The two values are the same if the field curve is that for a uniform earth, but will differ if the field curve is not characteristic of a uniform earth. If the second layer is more conductive than the surface layer, the resistivity determined from the vertical scale, ρ_1 , will be lower than the resistivity determined from the horizontal scale (this value is computed as t_0/u_0R^2 , where t_0 is the time on the field plot that corresponds to the time origin on the theoretical plot, u_0 is the magnetic permeability and R is the separation from source to receiver). The ratio of ρ_1 to t_0/u_0R^2 may then be used to find the depth to the conductive second layer with the aid of the curves shown in Figure 26 provided one may make a crude estimate of the contrast in conductivity between the first and

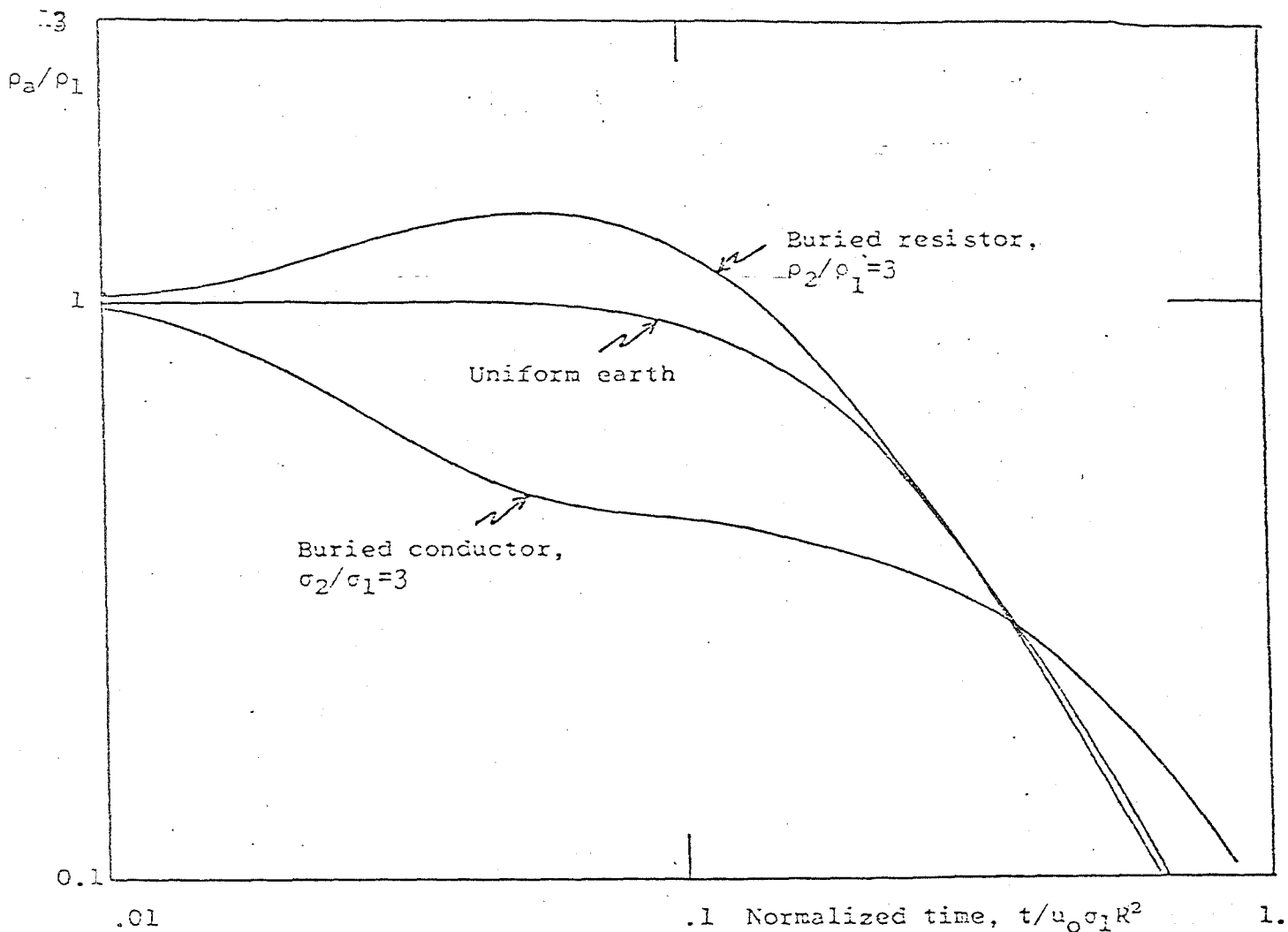

Figure 25. Examples of two-layer electromagnetic sounding curves for the case in which the thickness of the first layer is 1/16 the separation, R.

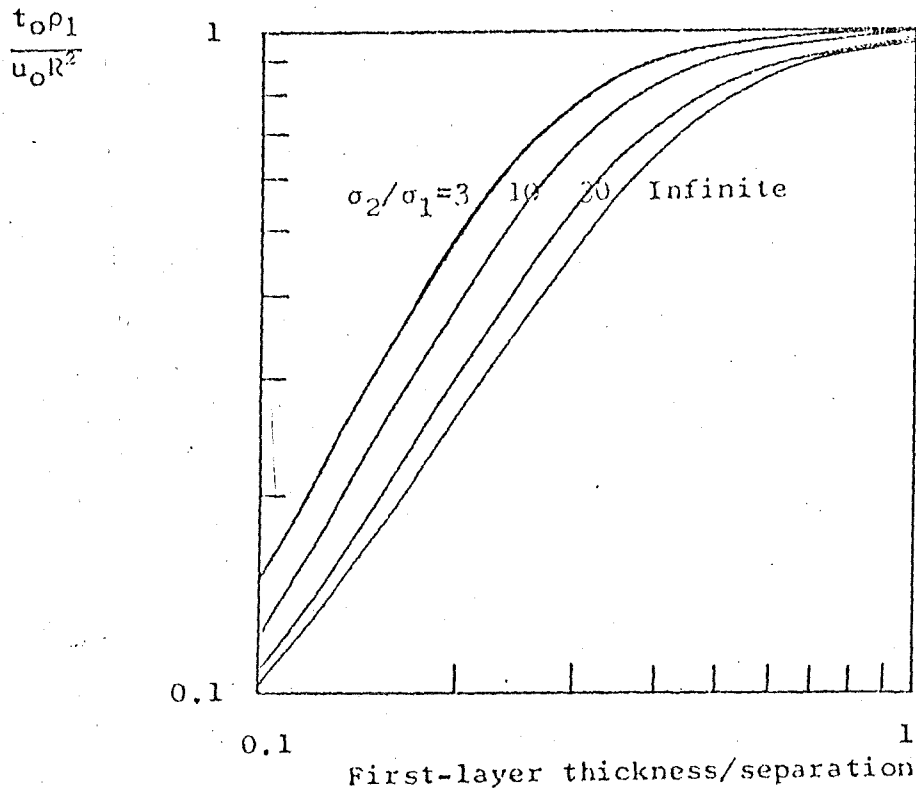

Figure 26. Interpretation chart for evaluating an electromagnetic sounding made over a sequence of two layers in which the second layer is more conductive than the first. The reference time t_0 is obtained by matching the field curve with the theoretical curve for a uniform earth. The first-layer resistivity is ρ_1 , magnetic permeability is u_0 and source-receiver separation is R .

second layers.

This procedure works only if the second layer is more conductive than the first layer. If the second layer is more resistive, the ratio of ρ_1 to t_0/u_0R^2 will be slightly greater than unity, but the value for the ratio will be nearly independent of the depth to the second layer. Therefore, an alternate approach must be used to make an interpretation. The diagnostic feature of an apparent resistivity curve for a buried insulating basement is that the value for apparent resistivity will rise from the value for the surface layer and pass through a maximum before it drops off to assume late-time behavior. The height of the maximum may be used to determine the depth to the insulating second layer, again providing that one may estimate the resistivity contrast between the first and second layers approximately. A ratio is formed between the maximum apparent resistivity and the apparent resistivity for the first layer. Then, the depth to the second layer may be determined using the curves shown in Figure 27.

These two procedures were used to carry out the interpretations of the electromagnetic soundings reported in the body of this report.

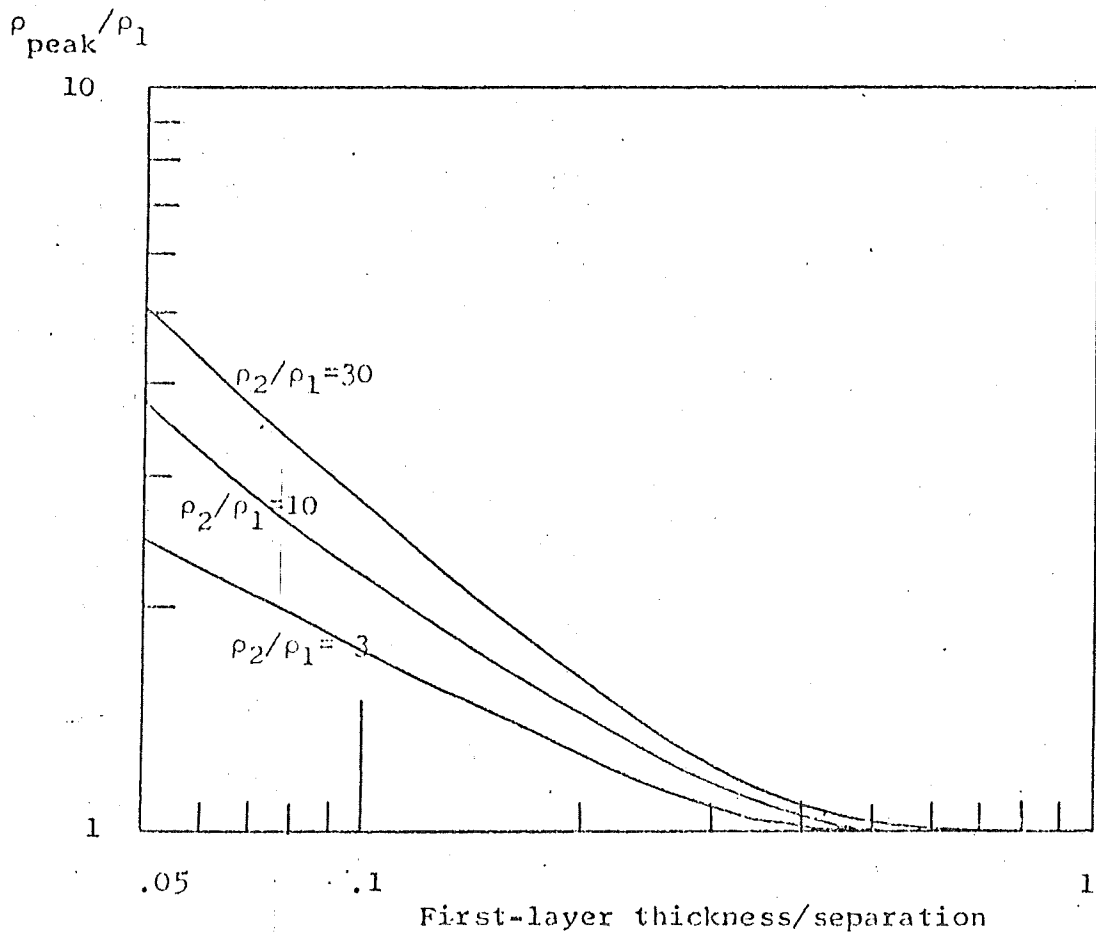

Figure 27. Interpretation chart for evaluating an electromagnetic sounding made over a sequence of two layers in which the second layer is more resistive than the first. Interpretation is based on the ratio of the peak resistivity recorded on the sounding to the first-layer resistivity.

APPENDIX II: Listing of electromagnetic sounding data.

The following quantities are tabulated:

- TIME : The length of time following the beginning of a transient at which the voltage is sampled, in seconds
- NUMBER : The number of individual samples added together to form an average
- AVERAGE : The average voltage at a given time, in millivolts (exponential format)
- ST. DEV. : Standard deviation of the voltage samples from which the average was formed, in millivolts (exponential format)
- RESISTIVITY : Apparent resistivity computed using Vanyan's formula, in ohm-meters

ELECTROMAGNETIC SOUNDING DATA
 UNION OIL COMPANY VALLES CALDER SOUNDING 501, 1972

OFFSET DISTANCE= 5300. METERS
 SOURCE LENGTH= 2500. METERS
 RECEIVER AREA=.1664 SQUARE KM
 CURRENT STEP=11.20 AMPERES

DIGITIZING SCALE IS 0.054MICROVOLTS/DIV

EDITED AND STACKED DATA

TIME	NUMBER	AVERAGE	ST. DEV.	RESISTIVITY
0.04	6	0.419E-04	0.795E-05	15.55
0.08	6	0.674E-04	0.464E-05	24.99
0.12	6	0.767E-04	0.351E-05	28.45
0.16	6	0.745E-04	0.427E-05	27.61
0.20	6	0.704E-04	0.585E-05	26.10
0.24	6	0.617E-04	0.694E-05	22.88
0.28	6	0.531E-04	0.631E-05	19.68
0.32	6	0.449E-04	0.587E-05	16.66
0.36	6	0.386E-04	0.693E-05	14.31
0.40	6	0.309E-04	0.521E-05	11.45
0.44	6	0.251E-04	0.580E-05	9.30
0.48	6	0.211E-04	0.715E-05	7.83
0.52	6	0.159E-04	0.481E-05	5.91
0.56	6	0.118E-04	0.390E-05	4.37
0.60	6	0.978E-05	0.493E-05	3.63
0.64	6	0.833E-05	0.481E-05	3.09
0.68	6	0.643E-05	0.549E-05	2.39
0.72	6	0.362E-05	0.401E-05	1.34
0.76	6	0.326E-05	0.362E-05	1.21
0.80	6	0.254E-05	0.312E-05	0.94
0.84	6	0.199E-05	0.309E-05	0.74
0.88	6	0.906E-06	0.309E-05	0.34
0.92	6	0.109E-05	0.331E-05	0.40
0.96	6	0.906E-06	0.455E-05	0.34
1.00	6	-0.181E-06	0.285E-05	-0.07
1.04	6	0.543E-06	0.344E-05	0.20
1.08	6	0.453E-06	0.333E-05	0.17
1.12	6	0.453E-06	0.333E-05	0.17
1.16	6	0.453E-06	0.333E-05	0.17
1.20	5	0.141E-05	0.818E-04	0.52
1.24	5	0.141E-05	0.818E-04	0.52
1.28	5	0.141E-05	0.818E-04	0.52
1.32	5	0.141E-05	0.818E-04	0.52
1.36	5	0.141E-05	0.817E-04	0.52
1.40	5	0.141E-05	0.107E-03	0.52
1.44	5	0.141E-05	0.107E-03	0.52
1.48	5	0.141E-05	0.107E-03	0.52
1.52	5	0.141E-05	0.107E-03	0.52
1.56	5	0.141E-05	0.107E-03	0.52

GROUP SEVEN

ELECTROMAGNETIC SOUNDING DATA
 UNION OIL COMPANY VALLES CALDERA SOUNDING 502, 1972

OFFSET DISTANCE= 6750. METERS
 SOURCE LENGTH= 2500. METERS
 RECEIVER AREA=.1664 SQUARE KM
 CURRENT STEP=11.20 AMPERES

DIGITIZING SCALE IS 0.022MICROVOLTS/DIV

EDITED AND STACKED DATA

TIME	NUMBER	AVERAGE	ST. DEV.	RESISTIVITY
0.04	7	0.135E-04	0.154E-05	12.76
0.08	7	0.179E-04	0.125E-05	16.96
0.12	7	0.208E-04	0.912E-06	19.64
0.16	7	0.212E-04	0.125E-05	20.10
0.20	7	0.215E-04	0.145E-05	20.34
0.24	7	0.216E-04	0.105E-05	20.42
0.28	7	0.214E-04	0.100E-05	20.22
0.32	7	0.193E-04	0.112E-05	18.27
0.36	7	0.183E-04	0.917E-06	17.36
0.40	7	0.165E-04	0.110E-05	15.62
0.44	7	0.151E-04	0.136E-05	14.25
0.48	7	0.139E-04	0.136E-05	13.20
0.52	7	0.119E-04	0.131E-05	11.22
0.56	7	0.111E-04	0.118E-05	10.46
0.60	7	0.103E-04	0.608E-06	9.70
0.64	7	0.871E-05	0.194E-05	8.25
0.68	7	0.739E-05	0.989E-06	6.99
0.72	7	0.613E-05	0.152E-05	5.80
0.76	6	0.560E-05	0.189E-05	5.30
0.80	7	0.477E-05	0.132E-05	4.52
0.84	7	0.416E-05	0.114E-05	3.93
0.88	7	0.323E-05	0.145E-05	3.06
0.92	6	0.205E-05	0.164E-05	1.94
0.96	7	0.311E-05	0.171E-05	2.94
1.00	7	0.302E-05	0.151E-05	2.86
1.04	7	0.354E-05	0.192E-05	3.35
1.08	7	0.222E-05	0.962E-06	2.10
1.12	7	0.225E-05	0.146E-05	2.13
1.16	6	0.104E-05	0.133E-05	0.99
1.20	6	0.230E-05	0.241E-04	2.18
1.24	6	0.162E-05	0.239E-04	1.53
1.28	6	0.119E-05	0.237E-04	1.12
1.32	6	0.718E-06	0.236E-04	0.68
1.36	6	0.115E-05	0.237E-04	1.09
1.40	6	0.158E-05	0.239E-04	1.50
1.44	6	0.158E-05	0.237E-04	1.50
1.48	6	0.399E-06	0.172E-05	0.38
1.52	6	0.162E-05	0.142E-04	1.53
1.56	6	0.172E-05	0.442E-04	1.63

GROUP SEVEN

ELECTROMAGNETIC SOUNDING DATA

UNION OIL COMPANY VALLE'S CALDERA SOUNDING 503, 1972

OFFSET DISTANCE= 7750. METERS
 SOURCE LENGTH= 2500. METERS
 RECEIVER AREA=.1664 SQUARE KM
 CURRENT STEP=11.20 AMPERES

DIGITIZING SCALE IS 0.022MICROVOLTS/DIV

EDITED AND STACKED DATA

TIME	NUMBER	AVERAGE	ST. DEV.	RESISTIVITY
0.04	2	0.251E-04	0.446E-05	40.89
0.08	2	0.257E-04	0.261E-05	41.78
0.12	2	0.260E-04	0.761E-06	42.31
0.16	2	0.248E-04	0.000E+00	40.36
0.20	2	0.228E-04	0.870E-06	37.17
0.24	2	0.223E-04	0.326E-06	36.29
0.28	2	0.218E-04	0.228E-05	35.58
0.32	2	0.191E-04	0.261E-05	31.16
0.36	2	0.195E-04	0.446E-05	31.69
0.40	2	0.149E-04	0.543E-06	24.25
0.44	2	0.105E-04	0.120E-05	17.17
0.48	2	0.978E-05	0.109E-05	15.93
0.52	2	0.105E-04	0.543E-06	17.17
0.56	2	0.946E-05	0.543E-06	15.40
0.60	2	0.880E-05	0.543E-06	14.34
0.64	2	0.663E-05	0.978E-06	10.80
0.68	2	0.565E-05	0.130E-05	9.21
0.72	2	0.457E-05	0.174E-05	7.43
0.76	2	0.424E-05	0.761E-06	6.90
0.80	2	0.370E-05	0.217E-06	6.02
0.84	2	0.293E-05	0.543E-06	4.78
0.88	2	0.217E-05	0.435E-06	3.54
0.92	2	0.207E-05	0.120E-05	3.36
0.96	2	0.261E-05	0.652E-06	4.25
1.00	2	0.228E-05	0.978E-06	3.72
1.04	2	0.217E-05	0.435E-06	3.54
1.08	2	0.337E-05	0.163E-05	5.49
1.12	2	0.239E-05	0.652E-06	3.89
1.16	2	0.239E-05	0.652E-06	3.89
1.20	2	0.239E-05	0.652E-06	3.89
1.24	2	0.163E-05	0.109E-06	2.66
1.28	2	0.163E-05	0.109E-06	2.66
1.32	2	0.228E-05	0.543E-06	3.72
1.36	2	0.228E-05	0.543E-06	3.72
1.40	2	0.228E-05	0.543E-06	3.72
1.44	2	0.228E-05	0.543E-06	3.72
1.48	2	0.228E-05	0.543E-06	3.72
1.52	2	0.228E-05	0.543E-06	3.72
1.56	2	0.228E-05	0.543E-06	3.72

GROUP SEVEN

ELECTROMAGNETIC SOUNDING DATA
 VALLES CALDERA EM SOUNDING 506

OFFSET DISTANCE= 6900. METERS
 SOURCE LENGTH= 2500. METERS
 RECEIVER AREA=.1664 SQUARE KM
 CURRENT STEP=11.50 AMPERES

DIGITIZING SCALE IS 0.022MICROVOLTS/DIV

EDITED AND STACKED DATA

TIME	NUMBER	AVERAGE	ST. DEV.	RESISTIVITY
0.04	5	0.115E-04	0.134E-05	12.45
0.08	5	0.134E-04	0.627E-06	14.50
0.12	5	0.150E-04	0.117E-05	16.19
0.16	5	0.156E-04	0.123E-05	16.84
0.20	5	0.167E-04	0.102E-05	18.06
0.24	5	0.171E-04	0.131E-05	18.43
0.28	5	0.165E-04	0.139E-05	17.87
0.32	5	0.145E-04	0.791E-06	15.72
0.36	5	0.134E-04	0.100E-05	14.46
0.40	5	0.116E-04	0.109E-05	12.59
0.44	5	0.970E-05	0.161E-05	10.48
0.48	5	0.861E-05	0.199E-05	9.31
0.52	5	0.706E-05	0.189E-05	7.63
0.56	5	0.571E-05	0.202E-05	6.18
0.60	5	0.398E-05	0.172E-05	4.30
0.64	5	0.307E-05	0.101E-05	3.32
0.68	5	0.281E-05	0.110E-05	3.04
0.72	5	0.216E-05	0.928E-06	2.34
0.76	5	0.195E-05	0.494E-06	2.11
0.80	5	0.186E-05	0.782E-06	2.01
0.84	5	0.126E-05	0.162E-06	1.36
0.88	5	0.126E-05	0.420E-06	1.36
0.92	5	0.104E-05	0.501E-06	1.12
0.96	5	0.909E-06	0.482E-06	0.98
1.00	5	0.866E-06	0.194E-06	0.94
1.04	5	0.264E-04	0.511E-04	28.54
1.08	5	0.265E-04	0.511E-04	28.59
1.12	5	0.265E-04	0.510E-04	28.63
1.16	5	0.265E-04	0.511E-04	28.59
1.20	5	0.265E-04	0.510E-04	28.68
1.24	5	0.263E-04	0.505E-04	28.41
1.28	5	0.897E-05	0.159E-04	9.69
1.32	5	0.897E-05	0.159E-04	9.69
1.36	5	0.897E-05	0.159E-04	9.69
1.40	5	0.897E-05	0.159E-04	9.69
1.44	5	0.897E-05	0.159E-04	9.69
1.48	5	0.897E-05	0.159E-04	9.69
1.52	5	0.897E-05	0.159E-04	9.69
1.56	5	0.897E-05	0.159E-04	9.69

GROUP SEVEN

ELECTROMAGNETIC SOUNDING DATA
VALLES CALDERA EM SOUNDING 507

OFFSET DISTANCE= 7500. METERS
SOURCE LENGTH= 2500. METERS
RECEIVER AREA=.1664 SQUARE KM
CURRENT STEP=11.50 AMPERES

DIGITIZING SCALE IS 0.022MICROVOLTS/DIV

EDITED AND STACKED DATA

TIME	NUMBER	AVERAGE	ST. DEV.	RESISTIVITY
0.04	3	0.413E-05	0.116E-05	6.66
0.08	3	0.725E-05	0.126E-05	11.68
0.12	3	0.928E-05	0.739E-06	14.95
0.16	3	0.942E-05	0.205E-06	15.19
0.20	3	0.993E-05	0.571E-06	16.00
0.24	3	0.986E-05	0.131E-05	15.89
0.28	3	0.949E-05	0.151E-05	15.30
0.32	3	0.833E-05	0.410E-06	13.43
0.36	3	0.783E-05	0.887E-06	12.62
0.40	3	0.645E-05	0.118E-05	10.40
0.44	3	0.543E-05	0.887E-06	8.76
0.48	3	0.457E-05	0.145E-05	7.36
0.52	3	0.420E-05	0.114E-05	6.78
0.56	3	0.333E-05	0.178E-05	5.37
0.60	3	0.232E-05	0.165E-05	3.74
0.64	3	0.225E-05	0.128E-05	3.62
0.68	3	0.130E-05	0.988E-06	2.10
0.72	3	0.152E-05	0.710E-06	2.45
0.76	3	0.123E-05	0.893E-06	1.99
0.80	3	0.870E-06	0.106E-05	1.40
0.84	3	0.870E-06	0.106E-05	1.40
0.88	3	0.725E-06	0.893E-06	1.17
0.92	3	0.435E-06	0.615E-06	0.70
0.96	3	0.217E-06	0.532E-06	0.35
1.00	3	0.435E-06	0.615E-06	0.70
1.04	3	0.435E-06	0.615E-06	0.70
1.08	3	0.435E-06	0.615E-06	0.70
1.12	3	0.435E-06	0.615E-06	0.70
1.16	3	0.435E-06	0.615E-06	0.70
1.20	3	0.435E-06	0.615E-06	0.70
1.24	3	0.435E-06	0.615E-06	0.70
1.28	3	-0.138E-05	0.232E-05	-2.22
1.32	3	-0.304E-04	0.432E-04	-48.95
1.36	3	-0.304E-04	0.432E-04	-48.95
1.40	3	-0.304E-04	0.432E-04	-48.95
1.44	3	-0.304E-04	0.432E-04	-48.95
1.48	3	-0.302E-04	0.430E-04	-48.66
1.52	3	-0.273E-04	0.389E-04	-43.98
1.56	3	-0.273E-04	0.389E-04	-43.98

GROUP SEVEN

ELECTROMAGNETIC SOUNDING DATA
VALLES CALDERA EM SOUNDING 508

OFFSET DISTANCE= 7000. METERS
SOURCE LENGTH= 2500. METERS
RECEIVER AREA=.1665 SQUARE KM
CURRENT STEP=11.50 AMPERES

DIGITIZING SCALE IS 0.022MICROVOLTS/DIV

EDITED AND STACKED DATA

TIME	NUMBER	AVERAGE	ST. DEV.	RESISTIVITY
0.04	5	0.190E-04	0.141E-05	20.25
0.08	5	0.203E-04	0.124E-05	21.58
0.12	5	0.203E-04	0.134E-05	21.63
0.16	5	0.203E-04	0.409E-06	21.58
0.20	5	0.211E-04	0.107E-05	22.50
0.24	5	0.204E-04	0.822E-06	21.76
0.28	5	0.185E-04	0.151E-05	19.74
0.32	5	0.169E-04	0.535E-06	17.95
0.36	5	0.154E-04	0.120E-05	16.39
0.40	5	0.130E-04	0.117E-05	13.82
0.44	5	0.109E-04	0.168E-05	11.57
0.48	5	0.927E-05	0.167E-05	9.87
0.52	5	0.784E-05	0.127E-05	8.36
0.56	5	0.621E-05	0.856E-06	6.61
0.60	5	0.552E-05	0.158E-05	5.88
0.64	5	0.478E-05	0.122E-05	5.10
0.68	5	0.418E-05	0.950E-06	4.45
0.72	5	0.341E-05	0.138E-05	3.63
0.76	5	0.272E-05	0.173E-05	2.89
0.80	5	0.259E-05	0.127E-05	2.76
0.84	5	0.211E-05	0.101E-05	2.25
0.88	5	0.224E-05	0.802E-06	2.39
0.92	5	0.164E-05	0.538E-06	1.74
0.96	5	0.121E-05	0.778E-06	1.29
1.00	5	0.819E-06	0.460E-06	0.87
1.04	5	0.690E-06	0.977E-06	0.73
1.08	5	0.733E-06	0.588E-06	0.78
1.12	5	0.560E-06	0.690E-06	0.60
1.16	5	0.560E-06	0.690E-06	0.60
1.20	5	0.560E-06	0.690E-06	0.60
1.24	5	0.560E-06	0.690E-06	0.60
1.28	5	0.560E-06	0.690E-06	0.60
1.32	5	0.560E-06	0.690E-06	0.60
1.36	5	0.560E-06	0.690E-06	0.60
1.40	5	0.560E-06	0.690E-06	0.60
1.44	5	0.560E-06	0.690E-06	0.60
1.48	5	0.560E-06	0.690E-06	0.60
1.52	5	0.560E-06	0.690E-06	0.60
1.56	5	0.212E-04	0.407E-04	22.55

GROUP SEVEN

ELECTROMAGNETIC SOUNDING DATA
 UNION OIL COMPANY VALLES CALDERA SOUNDING601, 1972

OFFSET DISTANCE= 3650. METERS
 SOURCE LENGTH= 2350. METERS
 RECEIVER AREA=.1664 SQUARE KM
 CURRENT STEP=11.50 AMPERES

DIGITIZING SCALE IS 0.536MICROVOLTS/DIV

EDITED AND STACKED DATA

TIME	NUMBER	AVERAGE	ST. DEV.	RESISTIVITY
0.04	6	0.489E-03	0.131E-03	70.79
0.08	6	0.949E-03	0.536E-04	137.32
0.12	6	0.101E-02	0.111E-04	145.60
0.16	5	0.857E-03	0.314E-04	124.09
0.20	6	0.637E-03	0.264E-04	92.15
0.24	6	0.476E-03	0.370E-04	68.85
0.28	6	0.321E-03	0.222E-04	46.46
0.32	6	0.232E-03	0.327E-04	33.52
0.36	6	0.146E-03	0.156E-04	21.10
0.40	6	0.112E-03	0.318E-04	16.18
0.44	6	0.733E-04	0.190E-04	10.61
0.48	6	0.528E-04	0.159E-04	7.64
0.52	6	0.411E-04	0.147E-04	5.95
0.56	6	0.411E-04	0.207E-04	5.95
0.60	6	0.125E-04	0.800E-05	1.81
0.64	6	0.268E-05	0.148E-04	0.39
0.68	6	0.894E-06	0.140E-04	0.13
0.72	6	0.715E-05	0.188E-04	1.04
0.76	6	-0.107E-04	0.619E-05	-1.55
0.80	6	-0.715E-05	0.101E-04	-1.04
0.84	5	0.536E-05	0.858E-05	0.78
0.88	6	-0.626E-05	0.785E-05	-0.91
0.92	6	-0.984E-05	0.187E-04	-1.42
0.96	6	-0.805E-05	0.123E-04	-1.16
1.00	6	-0.894E-05	0.115E-04	-1.29
1.04	6	-0.134E-04	0.123E-04	-1.94
1.08	5	-0.161E-04	0.678E-03	-2.33
1.12	5	-0.161E-04	0.678E-03	-2.33
1.16	5	-0.161E-04	0.678E-03	-2.33
1.20	5	-0.161E-04	0.678E-03	-2.33
1.24	5	-0.161E-04	0.678E-03	-2.33
1.28	6	-0.134E-04	0.123E-04	-1.94
1.32	6	-0.134E-04	0.123E-04	-1.94
1.36	6	-0.134E-04	0.123E-04	-1.94
1.40	6	-0.134E-04	0.123E-04	-1.94
1.44	6	-0.134E-04	0.123E-04	-1.94
1.48	6	-0.134E-04	0.123E-04	-1.94
1.52	6	-0.134E-04	0.123E-04	-1.94
1.56	6	-0.134E-04	0.123E-04	-1.94

GROUP SEVEN

ELECTROMAGNETIC SOUNDING DATA

UNION OIL COMPANY VALLES CALDERA SOUNDING 602, 1972

OFFSET DISTANCE= 3950. METERS

SOURCE LENGTH= 2350. METERS

RECEIVER AREA=.1664 SQUARE KM

CURRENT STEP=11.50 AMPERES

DIGITIZING SCALE IS 0.021MICROVOLTS/DIV

EDITED AND STACKED DATA

TIME	NUMBER	AVERAGE	ST. DEV.	RESISTIVITY
0.04	3	0.427E-04	0.568E-05	7.67
0.08	3	0.682E-04	0.157E-05	12.27
0.12	3	0.677E-04	0.198E-05	12.18
0.16	3	0.573E-04	0.263E-05	10.30
0.20	3	0.476E-04	0.267E-05	8.56
0.24	3	0.337E-04	0.119E-05	6.06
0.28	3	0.247E-04	0.705E-06	4.45
0.32	3	0.177E-04	0.872E-06	3.19
0.36	3	0.134E-04	0.211E-05	2.41
0.40	3	0.110E-04	0.861E-06	1.99
0.44	3	0.776E-05	0.806E-06	1.40
0.48	3	0.484E-05	0.105E-05	0.87
0.52	3	0.249E-05	0.124E-05	0.45
0.56	3	0.150E-05	0.149E-05	0.27
0.60	3	0.641E-06	0.923E-06	0.12
0.64	3	0.285E-06	0.824E-06	0.05
0.68	3	0.142E-06	0.112E-05	0.03
0.72	3	-0.285E-06	0.439E-06	-0.05
0.76	3	-0.150E-05	0.106E-05	-0.27
0.80	3	-0.997E-06	0.661E-06	-0.18
0.84	3	-0.570E-06	0.561E-06	-0.10
0.88	3	-0.427E-06	0.629E-06	-0.08
0.92	3	-0.356E-06	0.533E-06	-0.06
0.96	3	-0.712E-07	0.201E-06	-0.01
1.00	3	0.214E-06	0.349E-06	0.04
1.04	3	0.214E-06	0.349E-06	0.04
1.08	3	0.340E-04	0.475E-04	6.12
1.12	3	0.340E-04	0.475E-04	6.12
1.16	3	0.340E-04	0.475E-04	6.12
1.20	3	0.340E-04	0.475E-04	6.12
1.24	3	0.340E-04	0.475E-04	6.12
1.28	3	0.340E-04	0.475E-04	6.12
1.32	3	0.214E-06	0.349E-06	0.04
1.36	3	0.214E-06	0.349E-06	0.04
1.40	3	0.214E-06	0.349E-06	0.04
1.44	3	0.214E-06	0.349E-06	0.04
1.48	3	0.214E-06	0.349E-06	0.04
1.52	3	0.214E-06	0.349E-06	0.04
1.56	3	0.214E-06	0.349E-06	0.04

GROUP SEVEN

ELECTROMAGNETIC SOUNDING DATA
 UNION OIL COMPANY VALLES CALDERA SOUNDING 603, 1972

OFFST DISTANCE= 4250. METERS
 SOURCE LENGTH= 2350. METERS
 RECEIVER AREA=.1664 SQUARE KM
 CURRENT STEP=11.50 AMPERES

DIGITIZING SCALE IS 0.054MICROVOLTS/DIV

EDITED AND STACKED DATA

TIME	NUMBER	AVERAGE	ST. DEV.	RESISTIVITY
0.04	5	0.494E-04	0.134E-04	10.53
0.08	5	0.112E-03	0.355E-04	23.91
0.12	5	0.120E-03	0.463E-04	25.56
0.16	5	0.105E-03	0.441E-04	22.33
0.20	5	0.813E-04	0.336E-04	17.35
0.24	5	0.643E-04	0.262E-04	13.71
0.28	5	0.473E-04	0.234E-04	10.09
0.32	5	0.344E-04	0.180E-04	7.35
0.36	5	0.240E-04	0.138E-04	5.13
0.40	5	0.176E-04	0.103E-04	3.75
0.44	5	0.121E-04	0.634E-05	2.59
0.48	5	0.837E-05	0.340E-05	1.73
0.52	5	0.376E-05	0.759E-06	0.80
0.56	5	0.258E-05	0.164E-05	0.55
0.60	5	0.161E-05	0.140E-05	0.34
0.64	5	0.751E-06	0.125E-05	0.16
0.68	5	0.377E-04	0.743E-04	8.03
0.72	5	0.396E-04	0.733E-04	8.44
0.76	5	0.387E-04	0.738E-04	8.26
0.80	5	-0.536E-06	0.348E-05	-0.11
0.84	5	-0.107E-06	0.248E-05	-0.02
0.88	5	-0.644E-06	0.858E-06	-0.14
0.92	5	-0.204E-05	0.142E-05	-0.43
0.96	5	-0.150E-05	0.115E-05	-0.32
1.00	5	-0.118E-05	0.526E-06	-0.25
1.04	5	-0.858E-06	0.872E-06	-0.18
1.08	5	-0.311E-05	0.412E-05	-0.66
1.12	5	-0.247E-04	0.469E-04	-5.26
1.16	5	-0.247E-04	0.469E-04	-5.26
1.20	5	-0.247E-04	0.469E-04	-5.26
1.24	5	-0.247E-04	0.469E-04	-5.26
1.28	5	-0.247E-04	0.469E-04	-5.26
1.32	5	-0.226E-04	0.429E-04	-4.83
1.36	5	-0.118E-05	0.526E-06	-0.25
1.40	5	-0.118E-05	0.526E-06	-0.25
1.44	5	-0.118E-05	0.526E-06	-0.25
1.48	5	-0.118E-05	0.526E-06	-0.25
1.52	5	-0.118E-05	0.526E-06	-0.25
1.56	5	-0.118E-05	0.526E-06	-0.25

GROUP SEVEN

ELECTROMAGNETIC SOUNDING DATA
 UNION OIL COMPANY VALLES CALDERA SOUNDING 604, 1972

OFFSET DISTANCE= 3900. METERS
 SOURCE LENGTH= 2350. METERS
 RECEIVER AREA=.1664 SQUARE KM
 CURRENT STEP=11.50 AMPERES

DIGITIZING SCALE IS 0.025MICROVOLTS/DIV

EDITED AND STACKED DATA

TIME	NUMBER	AVERAGE	ST. DEV.	RESISTIVITY
0.04	6	0.785E-04	0.196E-04	9.55
0.08	6	0.171E-03	0.177E-04	20.83
0.12	6	0.192E-03	0.430E-05	23.36
0.16	6	0.176E-03	0.104E-04	21.41
0.20	6	0.146E-03	0.108E-04	17.79
0.24	6	0.110E-03	0.866E-05	13.35
0.28	6	0.736E-04	0.942E-05	8.94
0.32	6	0.517E-04	0.883E-05	6.28
0.36	6	0.360E-04	0.323E-05	4.38
0.40	6	0.265E-04	0.443E-05	3.22
0.44	5	0.196E-04	0.455E-05	2.38
0.48	6	0.115E-04	0.263E-05	1.40
0.52	6	0.745E-05	0.174E-05	0.91
0.56	6	0.559E-05	0.129E-05	0.68
0.60	6	0.457E-05	0.140E-05	0.56
0.64	6	0.250E-05	0.198E-05	0.30
0.68	5	0.239E-05	0.127E-04	0.29
0.72	5	0.178E-05	0.125E-04	0.22
0.76	5	0.102E-05	0.123E-04	0.12
0.80	6	0.847E-06	0.183E-05	0.10
0.84	6	0.593E-06	0.159E-05	0.07
0.88	6	0.339E-06	0.143E-05	0.04
0.92	6	0.423E-06	0.115E-05	0.05
0.96	6	0.127E-05	0.167E-05	0.15
1.00	6	0.119E-05	0.187E-05	0.14
1.04	6	0.106E-05	0.104E-05	0.13
1.08	6	0.169E-06	0.107E-05	0.02
1.12	5	0.152E-06	0.207E-05	0.02
1.16	6	-0.423E-06	0.924E-06	-0.05
1.20	6	-0.212E-06	0.909E-06	-0.03
1.24	6	0.423E-06	0.111E-05	0.05
1.28	6	0.720E-06	0.873E-06	0.09
1.32	5	0.127E-05	0.118E-05	0.15
1.36	6	-0.169E-06	0.131E-05	-0.02
1.40	6	0.847E-07	0.117E-05	0.01
1.44	6	-0.635E-06	0.279E-05	-0.08
1.48	6	-0.381E-06	0.204E-05	-0.05
1.52	6	0.847E-07	0.153E-05	0.01
1.56	6	0.127E-06	0.192E-05	0.02

GROUP SEVEN

ELECTROMAGNETIC SOUNDING DATA CALDERA SOUNDING 605,
UNION OIL COMPANY VALLES

OFFSET DISTANCE= 4100. METERS
SOURCE LENGTH= 2350. METERS
RECEIVER AREA=.1664 SQUARE KM
CURRENT STEP=11.50 AMPERES

DIGITIZING SCALE IS 0.054MICROVOLTS/DIV

EDITED AND STACKED DATA

TIME	NUMBER	AVERAGE	ST. DEV.	RESISTIVITY
0.04	5	0.771E-04	0.187E-04	10.20
0.08	5	0.145E-03	0.156E-04	19.26
0.12	6	0.167E-03	0.361E-05	22.06
0.16	6	0.157E-03	0.654E-05	20.80
0.20	6	0.134E-03	0.715E-05	17.79
0.24	5	0.107E-03	0.123E-04	14.12
0.28	5	0.766E-04	0.610E-04	10.15
0.32	5	0.556E-04	0.532E-04	7.37
0.36	5	0.418E-04	0.481E-04	5.53
0.40	5	0.304E-04	0.439E-04	4.03
0.44	5	0.214E-04	0.402E-04	2.84
0.48	5	0.130E-04	0.362E-04	1.72
0.52	5	0.606E-05	0.283E-04	0.80
0.56	5	0.476E-05	0.285E-04	0.63
0.60	5	0.476E-05	0.293E-04	0.63
0.64	5	0.314E-05	0.295E-04	0.42
0.68	5	0.119E-05	0.293E-04	0.16
0.72	5	0.152E-05	0.294E-04	0.20
0.76	5	0.238E-05	0.296E-04	0.32
0.80	6	0.271E-06	0.350E-05	0.04
0.84	6	-0.171E-05	0.339E-05	-0.23
0.88	6	-0.451E-06	0.404E-05	-0.06
0.92	6	-0.722E-06	0.433E-05	-0.10
0.96	6	-0.451E-06	0.425E-05	-0.06
1.00	6	-0.126E-05	0.321E-05	-0.17
1.04	6	-0.135E-05	0.314E-05	-0.18
1.08	6	-0.162E-05	0.305E-05	-0.21
1.12	6	-0.180E-05	0.301E-05	-0.24
1.16	6	-0.189E-05	0.301E-05	-0.25
1.20	6	-0.189E-05	0.301E-05	-0.25
1.24	6	-0.180E-05	0.299E-05	-0.24
1.28	6	-0.180E-05	0.299E-05	-0.24
1.32	6	-0.180E-05	0.299E-05	-0.24
1.36	6	-0.198E-05	0.301E-05	-0.26
1.40	6	-0.198E-05	0.301E-05	-0.26
1.44	6	-0.198E-05	0.301E-05	-0.26
1.48	6	-0.198E-05	0.301E-05	-0.26
1.52	6	-0.198E-05	0.301E-05	-0.26
1.56	6	-0.198E-05	0.301E-05	-0.26

GROUP SEVEN

ELECTROMAGNETIC SOUNDING DATA
 UNION OIL COMPANY VALLES CALDERA SOUNDING 606, 1972

OFFSET DISTANCE= 5500. METERS
 SOURCE LENGTH= 2350. METERS
 RECEIVER AREA=.1664 SQUARE KM
 CURRENT STEP=12.60 AMPERES

DIGITIZING SCALE IS 0.022MICROVOLTS/DIV

EDITED AND STACKED DATA

TIME	NUMBER	AVERAGE	ST. DEV.	RESISTIVITY
0.04	7	0.535E-05	0.166E-05	2.09
0.08	8	0.112E-04	0.301E-05	4.38
0.12	7	0.165E-04	0.247E-05	6.44
0.16	7	0.198E-04	0.238E-05	7.73
0.20	8	0.219E-04	0.135E-05	8.59
0.24	8	0.217E-04	0.134E-05	8.48
0.28	7	0.197E-04	0.340E-04	7.71
0.32	7	0.178E-04	0.334E-04	6.96
0.36	7	0.156E-04	0.326E-04	6.10
0.40	7	0.122E-04	0.315E-04	4.78
0.44	7	0.894E-05	0.304E-04	3.50
0.48	7	0.711E-05	0.298E-04	2.78
0.52	7	0.609E-05	0.220E-04	2.38
0.56	7	0.560E-05	0.283E-04	2.19
0.60	7	0.380E-05	0.361E-04	1.49
0.64	7	0.238E-05	0.294E-04	0.93
0.68	7	0.179E-05	0.367E-04	0.70
0.72	7	0.186E-05	0.295E-04	0.73
0.76	7	0.139E-05	0.133E-04	0.54
0.80	8	0.595E-06	0.801E-06	0.23
0.84	7	0.433E-06	0.998E-06	0.17
0.88	8	0.568E-06	0.980E-06	0.22
0.92	7	0.340E-06	0.102E-05	0.13
0.96	8	0.162E-06	0.716E-06	0.06
1.00	8	-0.108E-06	0.108E-05	-0.04
1.04	7	0.186E-06	0.114E-05	0.07
1.08	7	-0.155E-06	0.343E-04	-0.06
1.12	7	0.928E-07	0.342E-04	0.04
1.16	7	0.618E-07	0.342E-04	0.02
1.20	7	-0.618E-07	0.343E-04	-0.02
1.24	7	-0.402E-06	0.344E-04	-0.16
1.28	8	-0.541E-07	0.106E-05	-0.02
1.32	7	0.124E-06	0.125E-05	0.05
1.36	8	-0.379E-06	0.135E-05	-0.15
1.40	7	-0.124E-06	0.908E-06	-0.05
1.44	7	-0.155E-06	0.101E-05	-0.06
1.48	7	-0.928E-07	0.109E-05	-0.04
1.52	7	-0.495E-06	0.194E-04	-0.19
1.56	7	-0.526E-06	0.194E-04	-0.21

GROUP SEVEN

ELECTROMAGNETIC SOUNDING DATA
 VALLES CALDERA EM SOUNDING 701

OFFSET DISTANCE= 3950. METERS
 SOURCE LENGTH= 1900. METERS
 RECEIVER AREA=.1665 SQUARE KM
 CURRENT STEP=19.00 AMPERES

DIGITIZING SCALE IS 0.054MICROVOLTS/DIV

EDITED AND STACKED DATA

TIME	NUMBER	AVERAGE	ST. DEV.	RESISTIVITY
0.04	5	0.124E-03	0.181E-04	11.32
0.08	5	0.161E-03	0.121E-05	14.68
0.12	5	0.122E-03	0.462E-05	11.10
0.16	5	0.841E-04	0.269E-05	7.65
0.20	5	0.522E-04	0.215E-05	4.75
0.24	5	0.314E-04	0.249E-05	2.86
0.28	5	0.166E-04	0.201E-05	1.51
0.32	5	0.909E-05	0.866E-06	0.83
0.36	5	0.541E-05	0.145E-05	0.49
0.40	5	0.249E-05	0.552E-06	0.23
0.44	5	0.195E-05	0.649E-06	0.18
0.48	5	0.866E-06	0.159E-05	0.08
0.52	5	-0.325E-06	0.106E-05	-0.03
0.56	5	-0.866E-06	0.111E-05	-0.08
0.60	5	-0.649E-06	0.116E-05	-0.06
0.64	5	-0.866E-06	0.943E-06	-0.08
0.68	5	-0.541E-06	0.123E-05	-0.05
0.72	5	-0.758E-06	0.139E-05	-0.07
0.76	5	-0.541E-06	0.123E-05	-0.05
0.80	5	-0.325E-06	0.121E-05	-0.03
0.84	5	-0.325E-06	0.121E-05	-0.03
0.88	5	-0.541E-06	0.123E-05	-0.05
0.92	5	-0.649E-06	0.130E-05	-0.06
0.96	5	-0.758E-06	0.139E-05	-0.07
1.00	5	-0.325E-06	0.121E-05	-0.03
1.04	5	-0.325E-06	0.121E-05	-0.03
1.08	5	-0.758E-06	0.139E-05	-0.07
1.12	5	-0.853E-14	0.145E-05	-0.00
1.16	5	-0.649E-06	0.130E-05	-0.06
1.20	5	-0.866E-06	0.152E-05	-0.08
1.24	5	-0.853E-14	0.145E-05	-0.00
1.28	5	-0.325E-06	0.121E-05	-0.03
1.32	5	0.931E-05	0.211E-04	0.85
1.36	5	0.635E-04	0.129E-03	5.78
1.40	5	0.639E-04	0.129E-03	5.81
1.44	5	0.641E-04	0.129E-03	5.83
1.48	5	0.635E-04	0.129E-03	5.73
1.52	5	0.624E-04	0.127E-03	5.63
1.56	5	0.569E-04	0.117E-03	5.18

GROUP SEVEN

ELECTROMAGNETIC SOUNDING DATA
VALLES CALDERA 702

ØFFEST DISTANCE= 4600. METERS
SOURCE LENGTH= 1900. METERS
RECEIVER AREA=.1664 SQUARE KM
CURRENT STEP=19.00 AMPERES

DIGITIZING SCALE IS 0.053MICROVØLTS/DIV

EDITED AND STACKED DATA

TIME	NUMBER	AVERAGE	ST. DEV.	RESISTIVITY
0.04	4	0.840E-04	0.449E-05	13.64
0.08	4	0.116E-03	0.116E-05	18.75
0.12	4	0.104E-03	0.305E-05	16.91
0.16	4	0.799E-04	0.339E-05	12.96
0.20	4	0.578E-04	0.465E-05	9.39
0.24	4	0.390E-04	0.372E-05	6.33
0.28	4	0.233E-04	0.205E-05	3.86
0.32	4	0.160E-04	0.262E-05	2.60
0.36	4	0.975E-05	0.378E-05	1.58
0.40	4	0.641E-05	0.259E-05	1.04
0.44	4	0.294E-05	0.886E-06	0.48
0.48	4	0.801E-06	0.886E-06	0.13
0.52	4	-0.801E-06	0.246E-05	-0.13
0.56	4	0.000E+00	0.327E-05	0.00
0.60	4	0.134E-06	0.308E-05	0.02
0.64	4	0.214E-05	0.352E-05	0.35
0.68	4	0.107E-05	0.348E-05	0.17
0.72	4	-0.267E-06	0.116E-05	-0.04
0.76	4	0.267E-06	0.153E-05	0.04
0.80	4	0.267E-06	0.179E-05	0.04
0.84	4	-0.267E-06	0.134E-05	-0.04
0.88	4	-0.801E-06	0.463E-06	-0.13
0.92	4	0.134E-06	0.954E-06	0.02
0.96	4	0.147E-05	0.291E-05	0.24
1.00	4	0.668E-06	0.157E-05	0.11
1.04	4	0.668E-06	0.157E-05	0.11
1.08	4	0.668E-06	0.157E-05	0.11
1.12	4	0.668E-06	0.157E-05	0.11
1.16	4	0.668E-06	0.157E-05	0.11
1.20	4	0.668E-06	0.157E-05	0.11
1.24	4	0.668E-06	0.157E-05	0.11
1.28	4	0.668E-06	0.157E-05	0.11
1.32	4	0.668E-06	0.157E-05	0.11
1.36	4	0.668E-06	0.157E-05	0.11
1.40	4	0.668E-06	0.157E-05	0.11
1.44	4	0.668E-06	0.157E-05	0.11
1.48	4	0.668E-06	0.157E-05	0.11
1.52	4	0.668E-06	0.157E-05	0.11
1.56	4	0.668E-06	0.157E-05	0.11

GROUP SEVEN

ELECTROMAGNETIC SOUNDING DATA
 VALLES CLADERA EM SOUNDING 703

OFFSET DISTANCE= 5400. METERS
 SOURCE LENGTH= 1900. METERS
 RECEIVER AREA=.1664 SQUARE KM
 CURRENT STEP=19.00 AMPERES

DIGITIZING SCALE IS 0.05 MICR0VOLTS/DIV

EDITED AND STACKED DATA

TIME	NUMBER	AVERAGE	ST. DEV.	RESISTIVITY
0.04	4	0.188E-04	0.966E-06	5.62
0.08	4	0.345E-04	0.234E-06	10.31
0.12	4	0.422E-04	0.251E-05	12.62
0.16	4	0.402E-04	0.189E-05	12.01
0.20	4	0.356E-04	0.135E-05	10.64
0.24	4	0.267E-04	0.104E-05	7.97
0.28	4	-0.312E-04	0.879E-04	-9.34
0.32	4	-0.341E-04	0.862E-04	-10.19
0.36	4	-0.371E-04	0.845E-04	-11.08
0.40	4	-0.395E-04	0.831E-04	-11.81
0.44	4	-0.410E-04	0.823E-04	-12.26
0.48	4	0.530E-04	0.834E-04	15.84
0.52	4	0.381E-04	0.607E-04	11.39
0.56	4	0.373E-04	0.611E-04	11.14
0.60	4	0.769E-04	0.132E-03	22.99
0.64	4	0.365E-04	0.616E-04	10.90
0.68	4	-0.445E-04	0.792E-04	-13.29
0.72	4	-0.427E-05	0.873E-05	-1.28
0.76	4	0.636E-04	0.108E-03	19.03
0.80	4	0.216E-05	0.304E-05	0.65
0.84	4	0.271E-06	0.124E-05	0.08
0.88	4	-0.122E-05	0.326E-05	-0.36
0.92	4	-0.135E-06	0.164E-05	-0.04
0.96	4	0.406E-06	0.117E-05	0.12
1.00	4	0.406E-06	0.117E-05	0.12
1.04	4	0.406E-06	0.117E-05	0.12
1.08	4	0.406E-06	0.117E-05	0.12
1.12	4	0.406E-06	0.117E-05	0.12
1.16	4	0.406E-06	0.117E-05	0.12
1.20	4	0.406E-06	0.117E-05	0.12
1.24	4	0.406E-06	0.117E-05	0.12
1.28	4	0.406E-06	0.117E-05	0.12
1.32	4	0.406E-06	0.117E-05	0.12
1.36	4	0.406E-06	0.117E-05	0.12
1.40	4	0.406E-06	0.117E-05	0.12
1.44	4	0.406E-06	0.117E-05	0.12
1.48	4	0.406E-06	0.117E-05	0.12
1.52	4	0.498E-04	0.847E-04	14.88
1.56	4	0.498E-04	0.847E-04	14.88

GROUP SEVEN

ELECTROMAGNETIC SOUNDING DATA
VALLES CALDERA 705

OFFSET DISTANCE= 5450. METERS
SOURCE LENGTH= 1900. METERS
RECEIVER AREA=.1664 SQUARE KM
CURRENT STEP=19.00 AMPERES

DIGITIZING SCALE IS 0.022MICROVOLTS/DIV

EDITED AND STACKED DATA

TIME	NUMBER	AVERAGE	ST. DEV.	RESISTIVITY
0.04	4	0.223E-04	0.195E-05	6.88
0.08	4	0.518E-04	0.141E-05	15.99
0.12	4	0.566E-04	0.137E-05	17.46
0.16	4	0.518E-04	0.245E-05	15.97
0.20	4	0.709E-04	0.456E-04	21.88
0.24	4	0.638E-04	0.497E-04	19.68
0.28	4	0.577E-04	0.532E-04	17.81
0.32	4	0.524E-04	0.563E-04	16.16
0.36	4	0.486E-04	0.584E-04	14.99
0.40	4	0.451E-04	0.605E-04	13.90
0.44	4	0.437E-04	0.611E-04	13.49
0.48	4	0.394E-04	0.576E-04	12.16
0.52	4	0.377E-04	0.581E-04	11.62
0.56	4	0.374E-04	0.576E-04	11.53
0.60	4	0.364E-04	0.580E-04	11.23
0.64	4	0.354E-04	0.582E-04	10.91
0.68	4	0.350E-04	0.581E-04	10.80
0.72	4	0.353E-04	0.579E-04	10.89
0.76	4	0.347E-04	0.581E-04	10.69
0.80	4	0.758E-06	0.899E-06	0.23
0.84	4	0.974E-06	0.622E-06	0.30
0.88	4	0.487E-06	0.281E-06	0.15
0.92	4	0.114E-05	0.756E-06	0.35
0.96	4	0.974E-06	0.583E-06	0.30
1.00	4	0.108E-05	0.667E-06	0.33
1.04	4	0.108E-05	0.667E-06	0.33
1.08	4	0.103E-05	0.619E-06	0.32
1.12	4	0.103E-05	0.619E-06	0.32
1.16	4	0.812E-06	0.560E-06	0.25
1.20	4	0.812E-06	0.560E-06	0.25
1.24	4	0.812E-06	0.560E-06	0.25
1.28	4	0.812E-06	0.560E-06	0.25
1.32	4	0.812E-06	0.560E-06	0.25
1.36	4	0.812E-06	0.560E-06	0.25
1.40	4	0.812E-06	0.560E-06	0.25
1.44	4	0.812E-06	0.560E-06	0.25
1.48	4	0.812E-06	0.560E-06	0.25
1.52	4	0.866E-06	0.552E-06	0.27
1.56	4	0.866E-06	0.552E-06	0.27

GROUP SEVEN

ELECTROMAGNETIC SOUNDING DATA
VALLES CALDERA 706

OFFSET DISTANCE= 5750. METERS
SOURCE LENGTH= 1900. METERS
RECEIVER AREA=.1664 SQUARE KM
CURRENT STEP=19.00 AMPERES

DIGITIZING SCALE IS 0.022MICROVOLTS/DIV

EDITED AND STACKED DATA

TIME	NUMBER	AVERAGE	ST. DEV.	RESISTIVITY
0.04	5	0.230E-04	0.285E-05	8.82
0.08	5	0.460E-04	0.170E-05	17.61
0.12	5	0.534E-04	0.111E-05	20.44
0.16	5	0.532E-04	0.978E-06	20.35
0.20	5	0.464E-04	0.180E-05	17.76
0.24	5	0.382E-04	0.160E-05	14.63
0.28	5	0.304E-04	0.200E-05	11.65
0.32	5	0.227E-04	0.208E-05	8.70
0.36	5	0.176E-04	0.148E-05	6.72
0.40	5	0.127E-04	0.133E-05	4.86
0.44	5	0.996E-05	0.219E-05	3.81
0.48	5	0.730E-05	0.155E-05	2.80
0.52	5	0.574E-05	0.134E-05	2.20
0.56	5	-0.604E-05	0.222E-04	-2.31
0.60	5	-0.648E-05	0.220E-04	-2.48
0.64	5	-0.787E-05	0.213E-04	-3.01
0.68	5	-0.822E-05	0.211E-04	-3.15
0.72	5	-0.826E-05	0.211E-04	-3.16
0.76	5	-0.842E-05	0.210E-04	-3.22
0.80	5	0.157E-05	0.795E-06	0.60
0.84	5	0.135E-05	0.574E-06	0.52
0.88	5	0.157E-05	0.863E-06	0.60
0.92	5	0.113E-05	0.636E-06	0.43
0.96	5	0.139E-05	0.488E-06	0.53
1.00	5	0.113E-05	0.606E-06	0.43
1.04	5	0.609E-06	0.422E-06	0.23
1.08	5	0.609E-06	0.503E-06	0.23
1.12	5	0.870E-06	0.790E-06	0.33
1.16	5	0.113E-05	0.906E-06	0.43
1.20	5	0.104E-05	0.770E-06	0.40
1.24	5	0.100E-05	0.709E-06	0.38
1.28	5	0.100E-05	0.709E-06	0.38
1.32	5	0.100E-05	0.709E-06	0.38
1.36	5	0.100E-05	0.709E-06	0.38
1.40	5	0.100E-05	0.709E-06	0.38
1.44	5	0.100E-05	0.709E-06	0.38
1.48	5	0.100E-05	0.709E-06	0.38
1.52	5	0.100E-05	0.709E-06	0.38
1.56	5	0.100E-05	0.709E-06	0.38

GROUP SEVEN

ELECTROMAGNETIC SOUNDING DATA
VALLES CALDERA 707

OFFSET DISTANCE= 6400. METERS
SOURCE LENGTH= 1900. METERS
RECEIVER AREA=.1664 SQUARE KM
CURRENT STEP=19.00 AMPERES

DIGITIZING SCALE IS 0.021MICROVOLTS/DIV

EDITED AND STACKED DATA

TIME	NUMBER	AVERAGE	ST. DEV.	RESISTIVITY
0.04	5	0.176E-04	0.315E-05	10.35
0.08	5	0.323E-04	0.119E-05	19.04
0.12	5	0.388E-04	0.975E-06	22.86
0.16	5	0.391E-04	0.130E-05	23.06
0.20	5	0.367E-04	0.497E-06	21.62
0.24	5	0.306E-04	0.142E-05	18.05
0.28	5	0.240E-04	0.808E-06	14.15
0.32	5	0.191E-04	0.119E-05	11.24
0.36	5	0.147E-04	0.151E-05	8.68
0.40	5	0.100E-04	0.173E-05	5.92
0.44	5	0.721E-05	0.994E-06	4.25
0.48	5	0.292E-04	0.477E-04	17.24
0.52	5	0.281E-04	0.483E-04	16.58
0.56	5	0.271E-04	0.488E-04	15.98
0.60	5	0.264E-04	0.492E-04	15.54
0.64	5	0.238E-04	0.450E-04	14.06
0.68	5	0.363E-05	0.473E-05	2.14
0.72	5	0.148E-05	0.191E-05	0.87
0.76	5	-0.131E-05	0.378E-05	-0.77
0.80	5	0.112E-05	0.173E-05	0.66
0.84	5	0.142E-05	0.124E-05	0.84
0.88	5	0.158E-04	0.287E-04	9.32
0.92	5	0.152E-04	0.290E-04	8.94
0.96	5	0.154E-04	0.289E-04	9.09
1.00	5	0.156E-04	0.288E-04	9.19
1.04	5	0.159E-04	0.286E-04	9.39
1.08	5	0.153E-04	0.289E-04	9.04
1.12	5	0.152E-04	0.286E-04	8.98
1.16	5	0.196E-05	0.319E-05	1.16
1.20	5	0.196E-05	0.319E-05	1.16
1.24	5	0.196E-05	0.319E-05	1.16
1.28	5	0.196E-05	0.319E-05	1.16
1.32	5	0.196E-05	0.319E-05	1.16
1.36	5	0.196E-05	0.319E-05	1.16
1.40	5	0.196E-05	0.319E-05	1.16
1.44	5	0.196E-05	0.319E-05	1.16
1.48	5	0.196E-05	0.319E-05	1.16
1.52	5	0.196E-05	0.319E-05	1.16
1.56	5	0.196E-05	0.319E-05	1.16

GROUP SEVEN

ELECTROMAGNETIC SOUNDING DATA
VALLES CALDERA 708

OFFSET DISTANCE= 4850. METERS
SOURCE LENGTH= 1900. METERS
RECEIVER AREA=.1664 SQUARE KM
CURRENT STEP=19.00 AMPERES

DIGITIZING SCALE IS 0.022MICROVOLTS/DIV

EDITED AND STACKED DATA

TIME	NUMBER	AVERAGE	ST. DEV.	RESISTIVITY
0.04	4	0.288E-04	0.419E-05	5.66
0.08	4	0.509E-04	0.671E-06	9.99
0.12	4	0.519E-04	0.155E-05	10.19
0.16	4	0.446E-04	0.542E-05	8.76
0.20	4	0.335E-04	0.318E-05	6.58
0.24	4	0.253E-04	0.206E-05	4.96
0.28	4	0.177E-04	0.902E-06	3.47
0.32	4	0.121E-04	0.134E-05	2.38
0.36	4	0.894E-05	0.117E-05	1.76
0.40	4	0.603E-05	0.175E-05	1.18
0.44	4	0.404E-05	0.204E-05	0.79
0.48	4	0.366E-05	0.172E-05	0.72
0.52	4	0.291E-05	0.122E-05	0.57
0.56	4	0.172E-05	0.927E-06	0.34
0.60	4	0.102E-05	0.752E-06	0.20
0.64	4	0.113E-05	0.919E-06	0.22
0.68	4	0.647E-06	0.403E-06	0.13
0.72	4	0.754E-06	0.444E-06	0.15
0.76	4	0.108E-05	0.549E-06	0.21
0.80	4	0.862E-06	0.264E-06	0.17
0.84	4	0.862E-06	0.264E-06	0.17
0.88	4	0.593E-06	0.414E-06	0.12
0.92	4	0.431E-06	0.664E-06	0.08
0.96	4	0.323E-06	0.842E-06	0.06
1.00	4	0.323E-06	0.842E-06	0.06
1.04	4	0.377E-06	0.854E-06	0.07
1.08	4	0.377E-06	0.854E-06	0.07
1.12	4	0.377E-06	0.854E-06	0.07
1.16	4	0.377E-06	0.854E-06	0.07
1.20	4	0.377E-06	0.854E-06	0.07
1.24	4	0.377E-06	0.854E-06	0.07
1.28	4	0.377E-06	0.854E-06	0.07
1.32	4	0.377E-06	0.854E-06	0.07
1.36	4	0.377E-06	0.854E-06	0.07
1.40	4	0.377E-06	0.854E-06	0.07
1.44	4	0.377E-06	0.854E-06	0.07
1.48	4	0.377E-06	0.854E-06	0.07
1.52	4	0.377E-06	0.854E-06	0.07
1.56	4	0.377E-06	0.854E-06	0.07

GROUP SEVEN

Apparent resistivities for electromagnetic soundings made from source 5, after correction for system response.

Time, sec.	Sounding					
	501	502	503	506	507	508
0.046	28.00	20.21	56.02	26.49	-31.85	23.55
0.051	28.42	19.69	51.64	26.06	-34.77	24.95
0.056	28.80	19.35	48.31	25.74	-36.66	25.98
0.062	29.12	19.19	45.86	25.52	-37.81	26.59
0.069	29.38	19.20	44.19	25.40	-38.40	26.75
0.077	29.59	19.38	43.20	25.38	-38.49	26.46
0.085	29.74	19.74	42.87	25.45	-38.11	25.72
0.094	29.83	20.28	43.17	25.63	-37.20	24.58
0.105	29.86	21.02	44.12	25.91	-35.63	23.08
0.116	29.83	21.99	45.76	26.29	-33.16	21.31
0.129	29.44	22.66	46.51	26.56	-30.95	20.17
0.143	28.34	22.31	44.26	26.40	-31.19	20.66
0.158	26.77	21.31	40.37	25.99	-33.07	22.28
0.176	25.30	20.54	37.81	25.89	-36.12	23.24
0.195	24.20	20.45	38.13	26.51	-39.81	22.15
0.216	22.67	20.42	38.53	26.05	-40.50	20.76
0.240	20.07	19.74	36.59	22.95	-32.86	20.32
0.266	17.63	18.94	34.04	22.44	-11.61	18.92
0.296	15.70	18.19	31.83	28.00	12.57	16.38
0.328	13.38	16.98	29.21	36.24	13.46	15.32
0.364	11.15	15.59	27.22	37.11	9.66	13.37
0.404	8.56	13.52	20.48	33.70	8.89	10.95
0.443	6.58	12.10	15.66	31.43	6.52	8.75
0.497	4.88	10.95	15.45	29.55	5.77	6.96
0.551	3.05	9.51	13.93	9.82	3.86	5.32
0.612	2.21	7.70	10.96	2.66	2.79	4.25
0.679	1.54	5.78	7.62	2.41	2.37	3.64
0.753	0.98	4.90	6.25	1.93	1.87	2.90
0.835	0.82	4.19	5.35	1.61	1.52	2.47
0.927	0.93	3.68	4.87	1.32	1.26	2.30
1.023	1.20	3.61	5.20	2.97	1.49	2.08
1.141	0.95	2.51	4.24		1.52	1.58
1.266	0.54	1.54	3.27		-14.90	0.79
1.405	0.53	1.20	3.31		-48.40	0.60

GROUP SEVEN

Apparent
resistivity, ohm-m
100

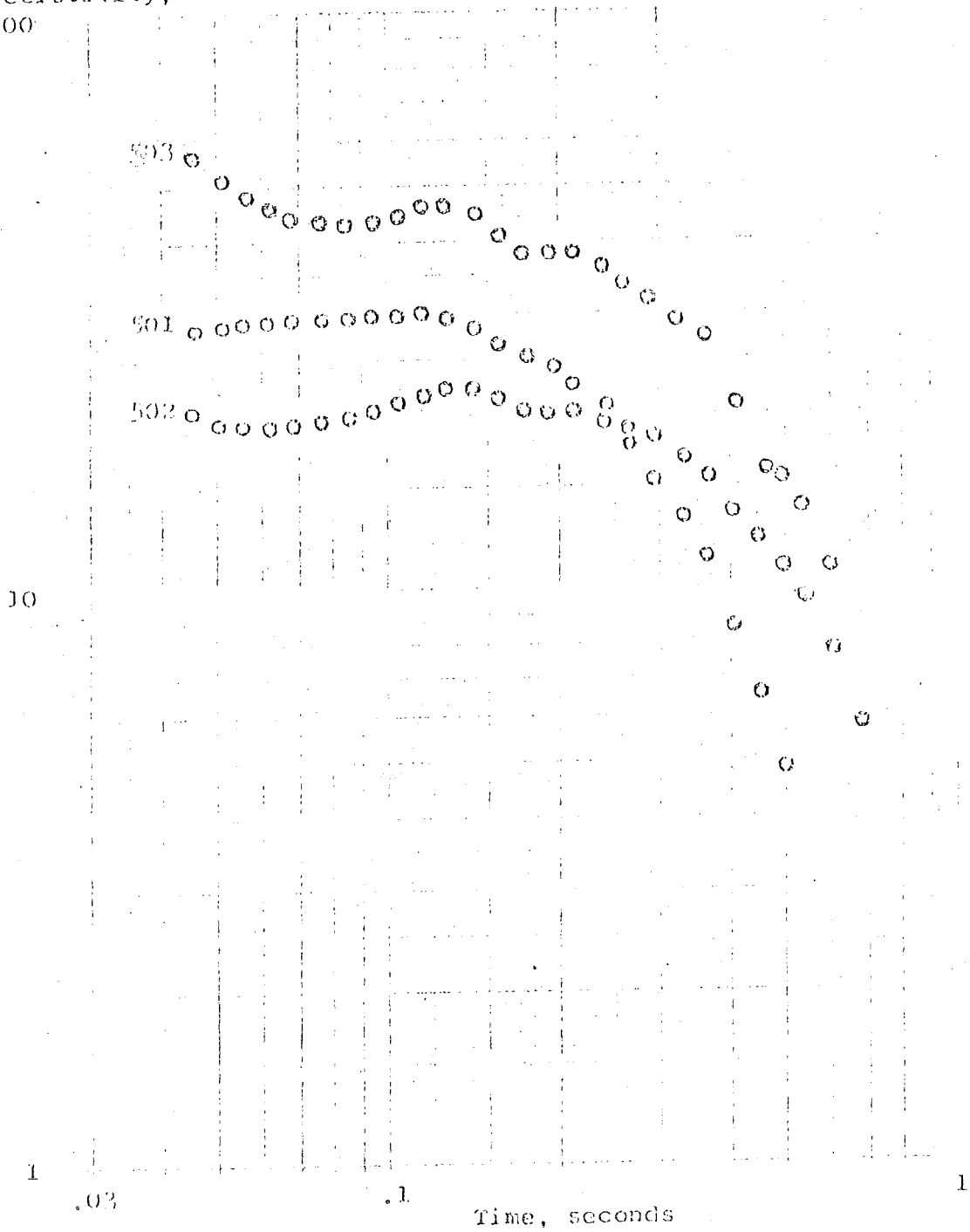

Figure 23. Electromagnetic soundings 501, 502 and 503.

GROUP SEVEN

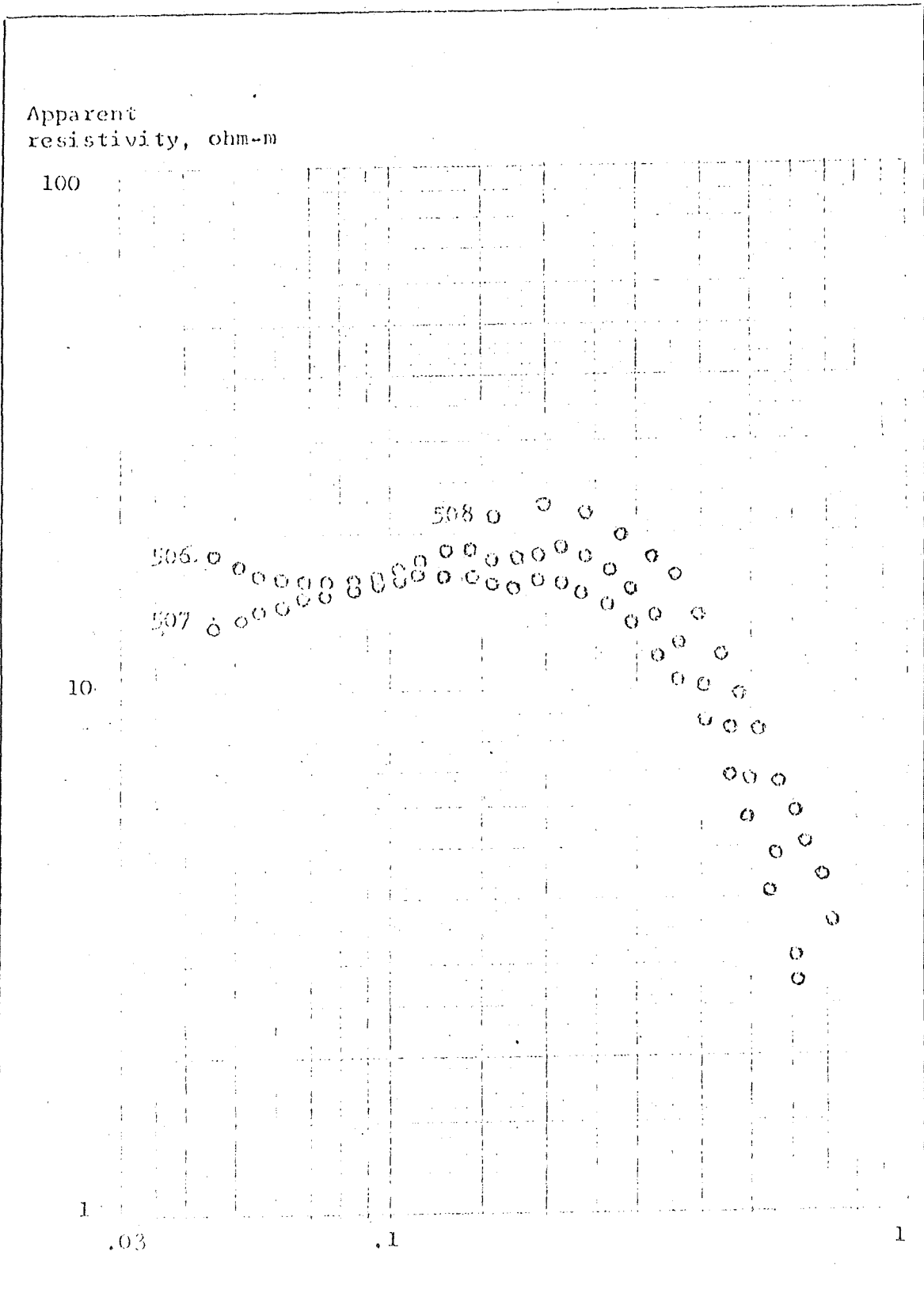

Figure 29. Electromagnetic soundings 506, 507 and 508.

GROUP SEVEN

Apparent resistivities for electromagnetic soundings made from source 6, after correction for system response.

Time	Sounding					
	601	602	603	604	605	606
0.046	143.70	13.69	24.19	21.30	20.11	4.30
0.051	150.26	13.97	25.91	22.62	20.93	4.58
0.056	155.29	14.11	27.30	23.73	21.63	4.87
0.062	158.60	14.12	28.29	24.59	22.20	5.18
0.069	160.10	13.98	28.86	25.18	22.63	5.51
0.077	159.73	13.72	28.97	25.47	22.90	5.85
0.085	157.51	13.32	28.63	25.45	23.02	6.21
0.094	153.50	12.81	27.85	25.13	22.97	6.59
0.105	147.85	12.19	26.66	24.52	22.76	7.00
0.116	140.74	11.49	25.10	23.64	22.40	7.42
0.129	130.78	10.71	23.37	22.44	21.67	7.80
0.143	116.74	9.84	21.67	20.90	20.34	8.05
0.158	100.86	8.91	19.90	19.13	18.64	8.19
0.176	85.90	7.58	17.45	17.15	16.87	8.28
0.195	72.95	5.83	14.13	15.00	15.17	8.35
0.216	60.26	4.74	10.27	12.59	13.14	8.24
0.240	47.18	4.94	6.21	9.89	10.60	7.78
0.266	35.67	6.35	3.41	7.37	8.21	7.07
0.296	25.98	8.38	1.72	5.34	6.25	6.27
0.328	17.35	7.61	-0.08	3.89	4.64	5.49
0.364	11.17	6.89	-1.34	2.75	3.46	4.61
0.404	7.32	6.57	-2.73	1.97	2.34	3.43
0.448	4.22	6.21	-2.71	1.28	1.34	2.35
0.497	2.43	2.29	-0.49	0.69	0.47	1.77
0.551	1.98	0.03	0.23	0.49	0.19	1.41
0.612	-0.26	-0.05	-0.03	0.35	0.21	0.84
0.679	-0.84	-0.06	2.41	0.18	0.07	0.50
0.753	-2.03	-0.23	4.09	0.11	0.03	0.37
0.835	-2.08	-0.24	3.22	0.09	0.04	0.31
0.927	0.04	-0.02	1.61	0.12	0.04	0.34
1.028	0.22	0.12	-0.02	0.18	0.10	0.46
1.141	-0.64	1.23	-3.47	0.12	-0.05	0.39
1.266	-2.04	3.79	-5.17	0.04	-0.23	0.00
1.405	-2.05	0.67	-4.66	-0.02	-0.26	-0.09

GROUP SEVEN

Apparent
resistivity, ohm-m.

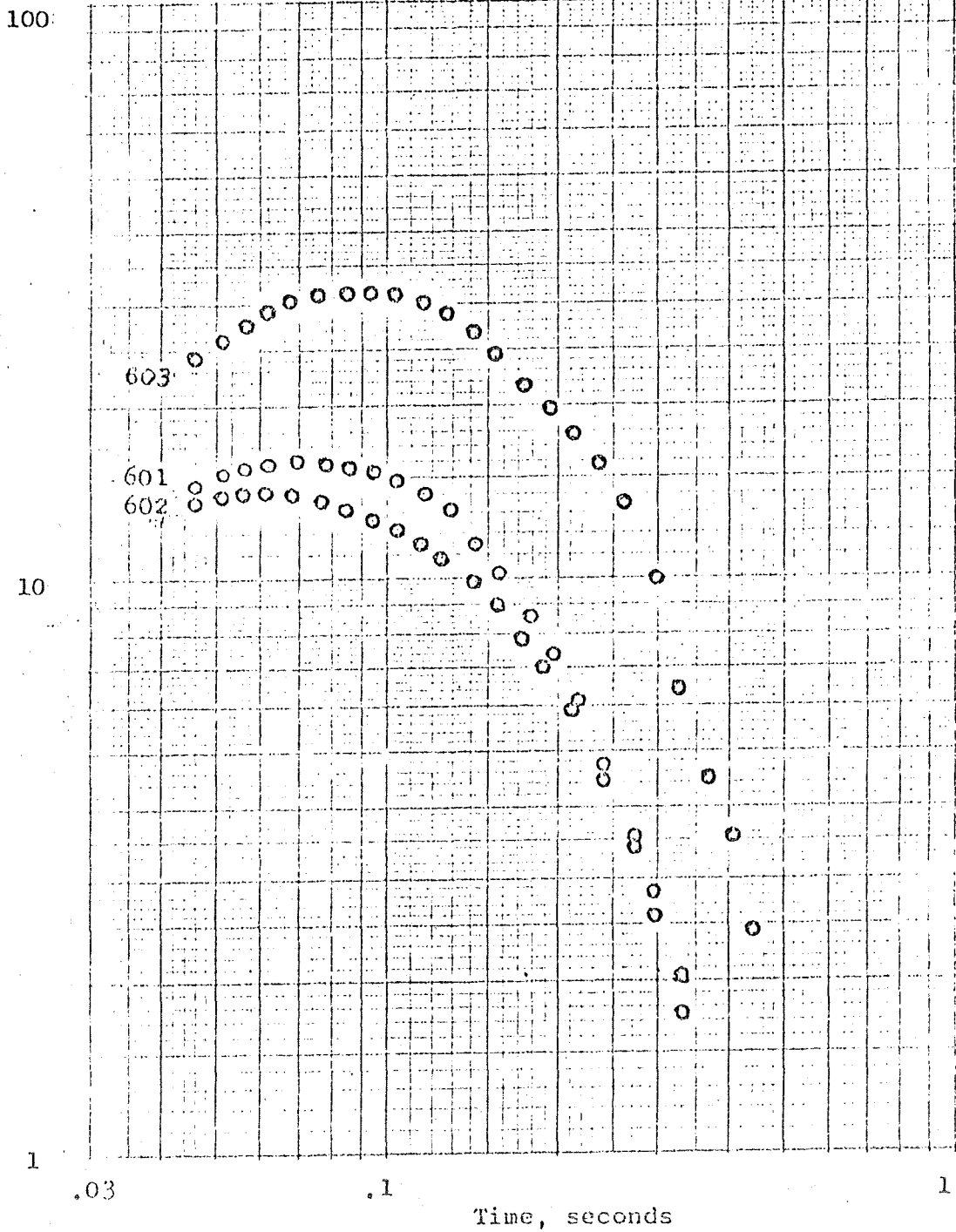

Figure 2Q. Electromagnetic soundings 601, 602 and 603.

GROUP SEVEN

Apparent resistivity,
ohm-meters

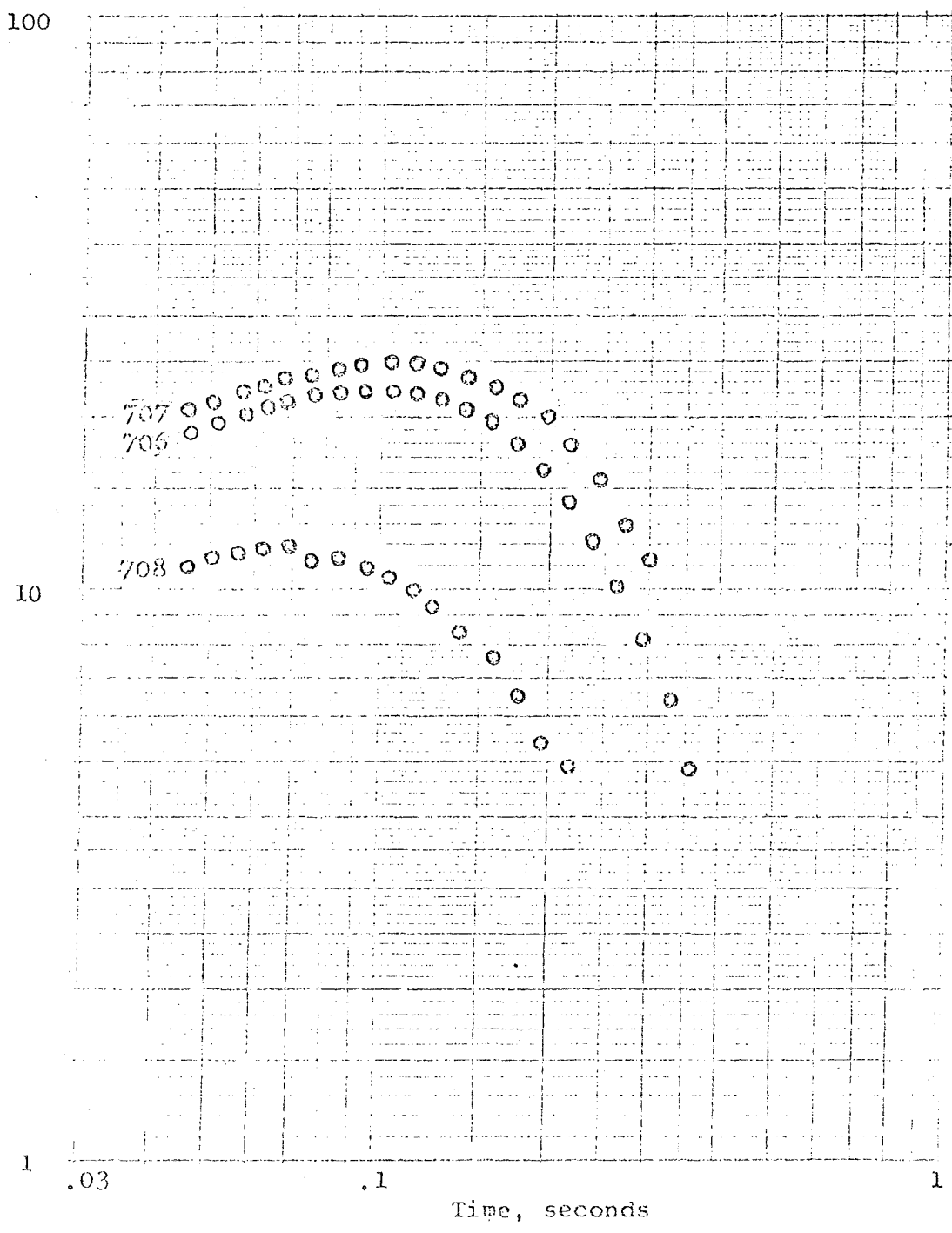

Figure 33. Electromagnetic soundings 706, 707 and 708.

Apparent resistivities for electromagnetic soundings made from source 7, after correction for system response.

Time	Sounding						
	701	702	703	705	706	707	708
0.046	23.19	22.08	18.16	16.39	18.65	21.23	10.92
0.051	23.07	21.72	16.09	17.81	19.52	22.03	11.23
0.056	22.70	21.25	14.49	18.98	20.28	22.77	11.44
0.062	22.09	20.66	13.31	19.84	20.93	23.42	11.55
0.069	21.26	19.97	12.50	20.34	21.45	23.99	11.54
0.077	20.24	19.20	12.02	20.46	21.83	24.46	11.43
0.085	19.06	18.34	11.86	20.18	22.06	24.83	11.21
0.094	17.75	17.42	12.01	19.53	22.15	25.10	10.90
0.105	16.35	16.45	12.48	18.54	22.08	25.26	10.49
0.116	14.89	15.44	13.29	17.26	21.87	25.31	10.00
0.129	13.60	14.09	13.68	16.44	21.39	25.03	9.34
0.143	12.69	12.15	12.66	16.90	20.50	24.36	8.40
0.153	11.97	10.04	10.83	18.27	19.32	23.28	7.34
0.176	10.68	8.36	9.66	19.81	17.85	21.98	6.33
0.195	8.57	7.27	9.94	20.94	16.07	20.53	5.43
0.216	5.36	5.94	7.07	20.77	14.18	18.55	4.56
0.240	2.12	4.06	-1.62	18.23	12.29	15.76	3.68
0.266	0.92	2.85	-10.61	15.98	10.28	13.14	2.85
0.296	0.58	2.19	-13.01	15.01	8.24	10.98	2.12
0.328	0.14	1.34	-12.24	13.56	6.45	8.64	1.55
0.364	0.05	0.93	-9.53	12.41	4.93	5.94	1.15
0.404	-0.01	0.50	-11.13	11.49	3.69	4.84	0.76
0.448	-0.04	0.10	-7.84	10.45	2.64	9.97	0.56
0.497	-0.11	-0.20	11.59	9.18	1.50	20.69	0.47
0.551	-0.15	-0.16	10.91	8.29	-1.79	19.12	0.26
0.612	-0.12	0.20	9.05	7.58	-2.21	15.86	0.15
0.679	-0.08	0.10	-4.22	6.59	-1.59	6.41	0.15
0.753	-0.05	-0.02	-1.74	4.73	-1.15	-0.17	0.17
0.835	-0.05	-0.02	2.50	4.00	-0.89	-0.28	0.15
0.927	-0.05	0.03	-0.89	4.03	-1.01	3.90	0.09
1.028	-0.04	0.04	4.47	3.33	-0.48	7.47	0.10
1.141	-0.02	0.03	0.90	1.62	0.44	3.12	0.12
1.266	-0.02	0.10	-0.46	0.40	0.46	1.15	0.08
1.405	1.19	0.11	0.12	0.25	0.38	1.16	0.07

GROUP SEVEN

Apparent resistivity, ohm-m

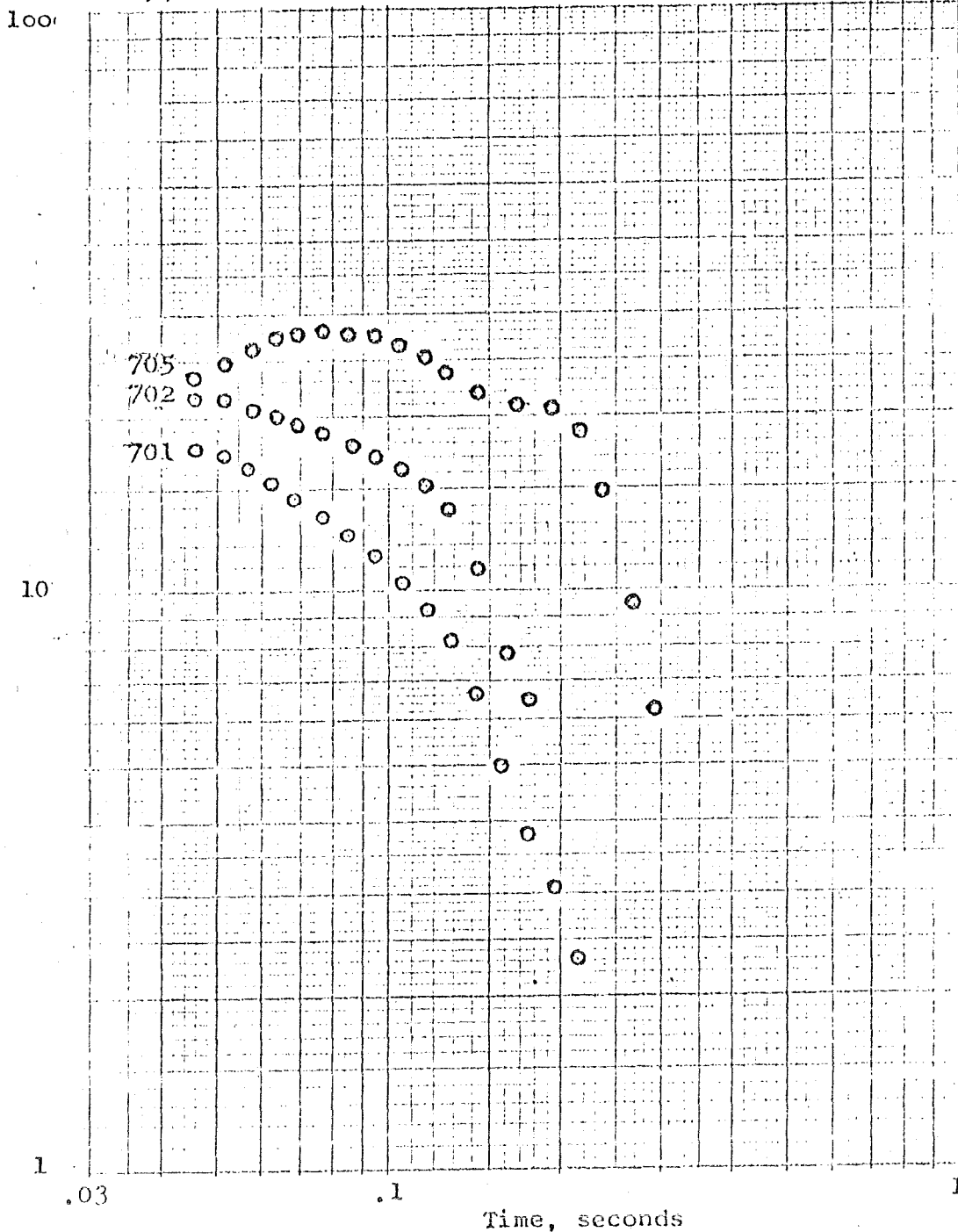

Figure 32. Electromagnetic soundings 701, 702 and 705.

Apparent resistivity,
ohm-meters

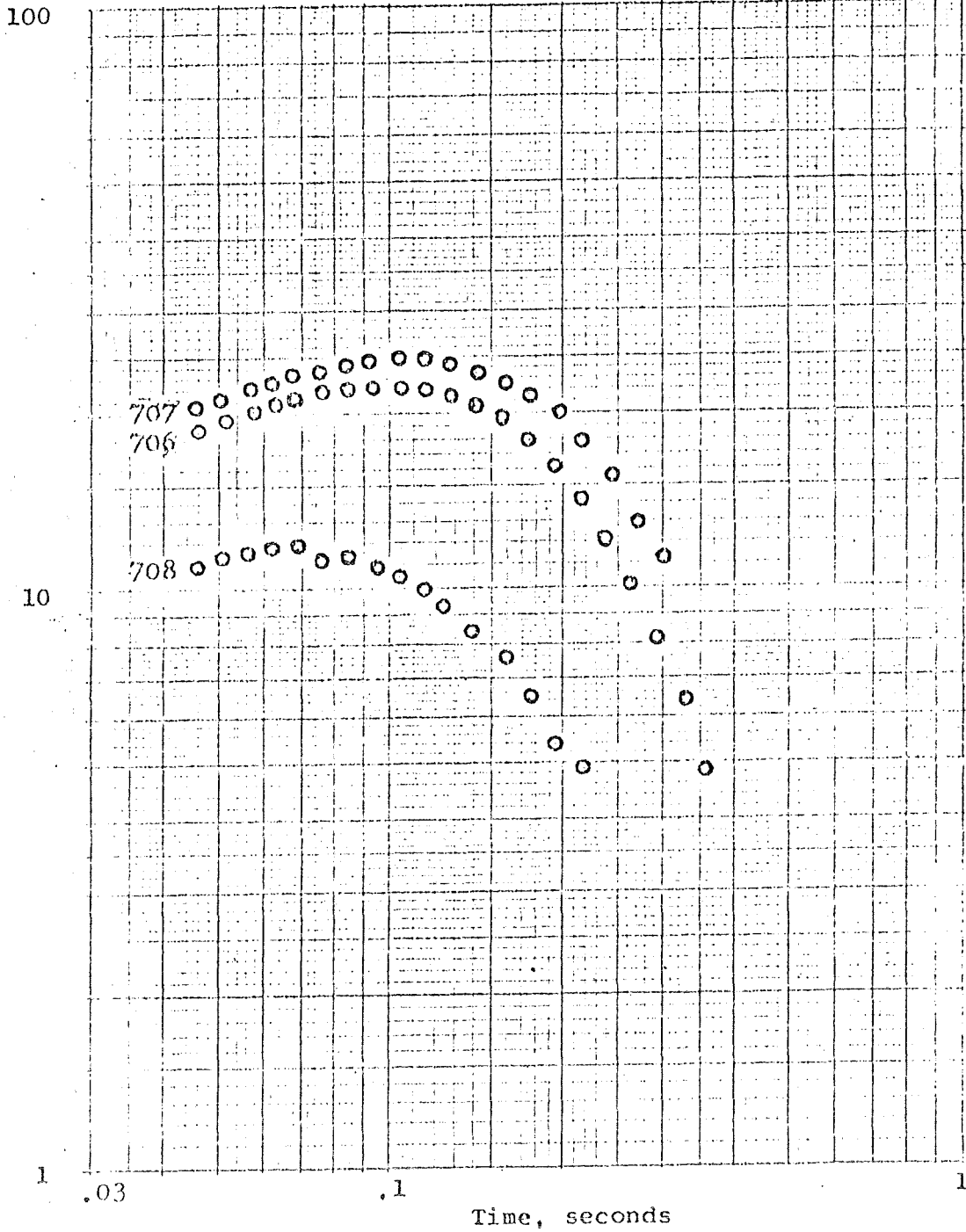

Figure 33. Electromagnetic soundings 706, 707 and 708.

References

Frischknecht, F. C., 1967, Fields about an oscillating magnetic dipole over a two-layer earth, and application to ground and airborne electromagnetic surveys; Quarterly of the Colo. Sch. of Mines, vol. 62, no. 1, pp. 1-326.

Keller, G. V., 1960, Physical properties of tuffs of the Oak Springs formation, Nevada; U. S. Geological Survey Professional Paper 400-B, pp. B396-B400.

Quist, A. S., and Marshall, W. L., 1966, Electrical conductances of aqueous solutions at high temperatures and pressures III. The conductances of potassium bisulfate solutions from 0 to 700° and at pressures to 4000 bars; J. Phys. Chem., vol. 70, p. 3714.

Quist, A. S., and Marshall, W. L., 1968, Electrical conductances of aqueous sodium chloride solutions from 0 to 800° and at pressures to 4000 bars; J. Phys. Chem., vol. 72, p. 684.

Silva, Luis R., 1969, Two-layer master curves for electromagnetic sounding; M. Sc. Thesis T-1250, Colo. Sch. of Mines, Golden, Colorado, 80 pp.

Vanyan, L. L., 1967, Electromagnetic depth soundings; Consultants Bureau, New York, 312 pp.

In addition to carrying out geophysical services, Group Seven offers management and consulting services for geothermal exploration. Interested organizations should contact:

Group Seven, Inc.
Geophysical Services Division
P. O. Box 374
Golden, Colorado 80401
Tel. 277-0641 or 277-0515