

LA-10934-OBES

GL04526

Drilling Report

First CSDP/Thermal Regimes Core Hole Project at Valles Caldera, New Mexico (VC-1)



Los Alamos Los Alamos National Laboratory
Los Alamos, New Mexico 87545

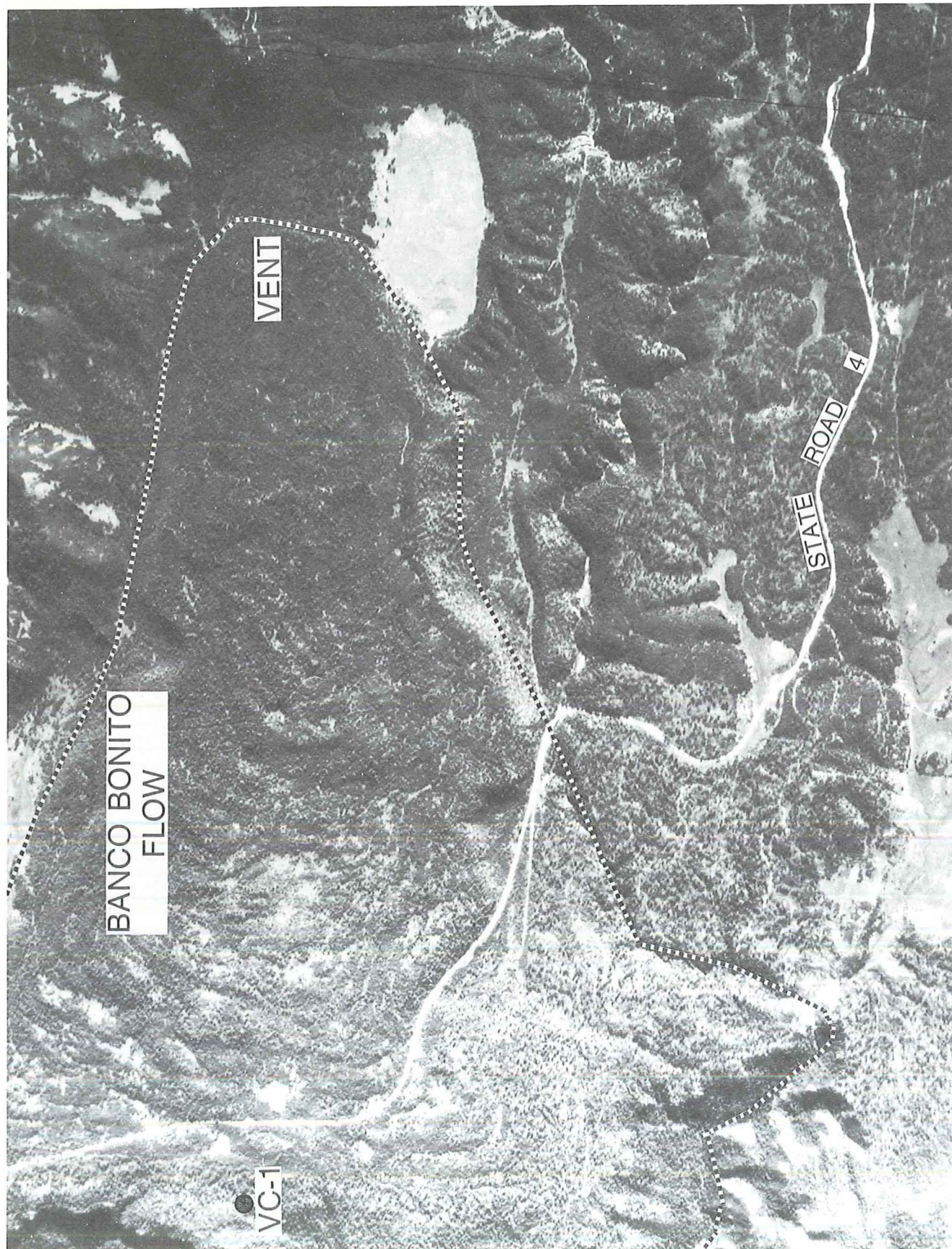

CONTENTS

ABSTRACT	1
I. INTRODUCTION, SCIENTIFIC GOALS, AND PRELIMINARY RESULTS . .	2
A. Objectives	2
B. Preliminary Results	2
II. HISTORICAL DEVELOPMENTS	6
III. CORE REQUIREMENTS AND RIG SPECIFICATIONS AND PROCUREMENT .	9
IV. SUMMARY OF CORING OPERATIONS	11
A. Site Preparation and Layout	11
B. Drilling Operations Summary and Daily History	18
C. Core Recovery	28
D. Core Bit Performance	31
E. Drilling Fluid	37
F. Blowout Preventer	42
V. GEOPHYSICAL LOGGING	45
VI. COST SUMMARY (1984\$)	48
ACKNOWLEDGMENTS	53
APPENDIX: WIRELINE CORE BARREL OPERATIONS AND E-CORE DEFINITION .	55
REFERENCES	60

Frontispiece

Aerial view of Banco Bonito obsidian flow. Note location of VC-1 relative to the Banco Bonito vent.

DRILLING REPORT
FIRST CSDP/THERMAL REGIMES CORE HOLE PROJECT
AT VALLES CALDERA, NEW MEXICO (VC-1)

Compiled and Edited by

J. Rowley, W. Hawkins, and J. Gardner

Contributors

J. Rowley, F. Goff, D. Miles, W. Hawkins, J. Gardner,
L. Pisto, G. Polk, S. Goff, and M. Mathews

ABSTRACT

This report is a review and summary of the core drilling operations of the first Valles Caldera research borehole (VC-1) under the Thermal Regimes element of the Continental Scientific Drilling Program (CSDP). The project is a portion of a broader program that seeks to answer fundamental scientific questions about magma, rock/water interactions, and volcanology through shallow (<1-km) core holes at Long Valley, California; Salton Sea, California; and the Valles Caldera, New Mexico. The report emphasizes coring operations with reference to the stratigraphy of the core hole, core quality description, core rig specifications, and performance. It is intended to guide future research on the core and in the borehole, as well as have applications to other areas and scientific problems in the Valles Caldera.

The primary objectives of this Valles Caldera coring effort were (1) to study the hydrogeochemistry of a subsurface geothermal outflow zone of the caldera near the source of convective upflow, (2) to obtain structural and stratigraphic information from intracaldera rock formations in the southern ring-fracture zone, and (3) to obtain continuous core samples through the youngest volcanic unit in Valles Caldera, the Banco Bonito rhyolite (approximately 0.1 Ma). All objectives were met. The high percentage of core recovery and the excellent quality of the samples are especially notable.

New field sample (core) handling and documentation procedures were successfully utilized. The procedures were designed to provide consistent field handling of the samples and logs obtained through the national CSDP.

I. INTRODUCTION, SCIENTIFIC GOALS, AND PRELIMINARY RESULTS

A. Objectives

The Valles Caldera Core Hole No. 1 (VC-1) is the first Continental Scientific Drilling Program (CSDP) (Thermal Regimes) core hole in the Valles Caldera (Goff et al. 1984). It is also the first continuously cored drill hole in the Jemez Mountain region. The primary scientific objectives of the core hole were to core the youngest intracaldera rhyolite (Banco Bonito rhyolite, age approximately 0.1 Ma), to obtain structural and stratigraphic information near the intersection of the Valles Caldera ring-fracture zone and the precaldera Jemez fault zone, and to investigate a high-temperature hydrothermal outflow plume near its source. The location of VC-1 in the southwestern moat of the caldera (Fig. 1) optimized the attainment of these three objectives. Once negotiations and site permitting were completed, coring of the 856-m hole was accomplished in 35 days ending on 3 September 1984. The coring effort was a complete success.

B. Preliminary Results

Core hole VC-1 (Fig. 2) penetrated 300 m of intracaldera volcanics, 35 m of volcaniclastic breccia, 91 m of Permian Abo Formation, 381 m of Pennsylvanian Madera Limestone, and 49 m of Pennsylvanian Sandia Formation with over 95% core recovery. These lithologies correlate well with cuttings from the Jemez Springs geothermal well and outcrops exposed in San Diego Canyon southwest of the caldera (Goff and Kron 1980). The stratigraphy leads us to believe that VC-1 stopped near the Precambrian basement. The Madera Limestone is approximately 120 m thicker than expected.

The volcanic section in VC-1, when compared with the geologic map of Smith et al. (1970), yielded some surprises. The Banco Bonito rhyolite is four times thicker than expected (149 m) suggesting that it filled a paleo-valley in the Valles Caldera moat. A previously unknown obsidian flow 19 m thick was encountered at 162 m depth. The lower volcanic sequence includes extremely lithic-rich Upper and Lower Bandelier Tuff interpreted as possible intracaldera facies and a pre-Bandelier ignimbrite recently recognized by Kite et al. (1982) southwest of the caldera. A 35-m-thick volcaniclastic clay-rich breccia containing predominantly altered andesite of the Paliza Canyon Formation underlies the volcanic sequence.

The volcaniclastic breccia and underlying Paleozoic rocks are faulted, sheared, and mineralized. Interpretations of data from oriented cores of

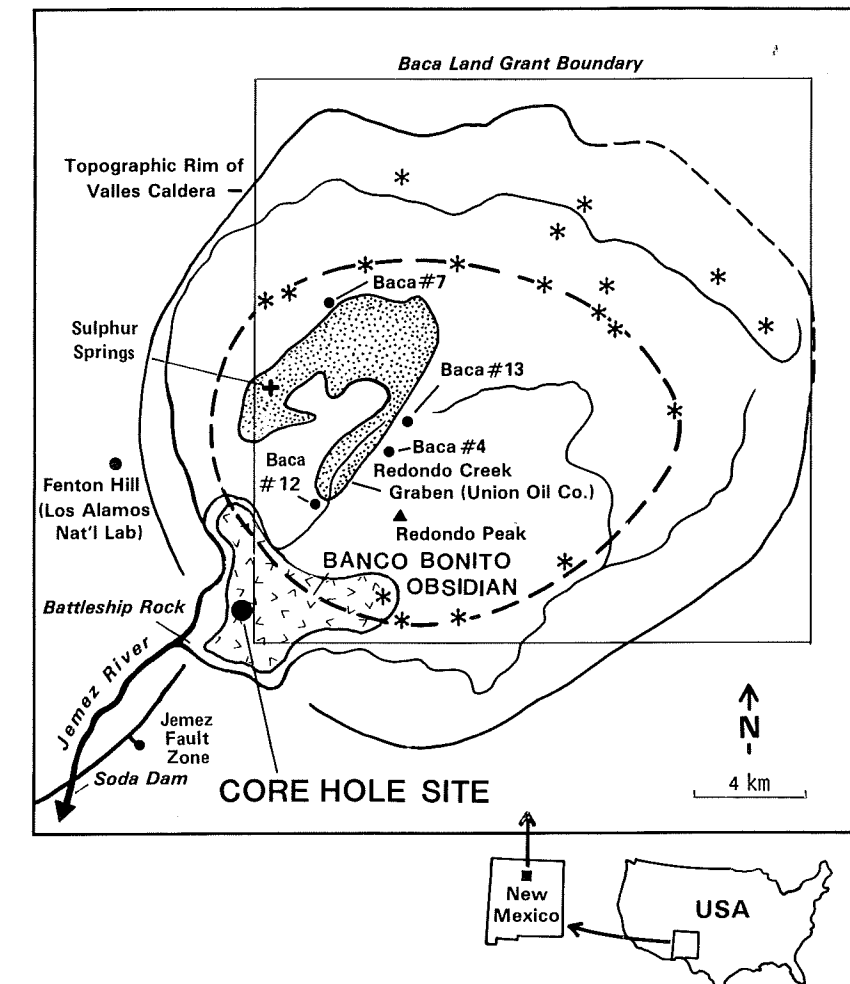

Fig. 1.

Sketch map of Valles Caldera showing the location of VC-1 relative to the ring-fracture zone and the Jemez fault zone. Stars denote moat rhyolite vents. Stipple pattern shows area of intense intracaldera surface hydrothermal alteration.

Madera Limestone at 476 m suggest deformation is possibly related to the nearby NE-trending Jemez fault zone (JFZ). These limestone beds strike approximately N35°E and dip 25°SE as opposed to the regional NE dip of the Paleozoic rocks.

Thermal aquifers were encountered at several horizons in the lower half of the core hole with the bottom-hole temperature (BHT) reaching 160°C (Fig. 3). Apparently, the volcaniclastic breccia acts as an impermeable barrier between cool aquifers in the volcanic sequence and thermal aquifers in Paleozoic rocks. The average thermal gradient from 350 to 750 m is 210°C/km, in agreement with the recently published thermal gradient analysis of the

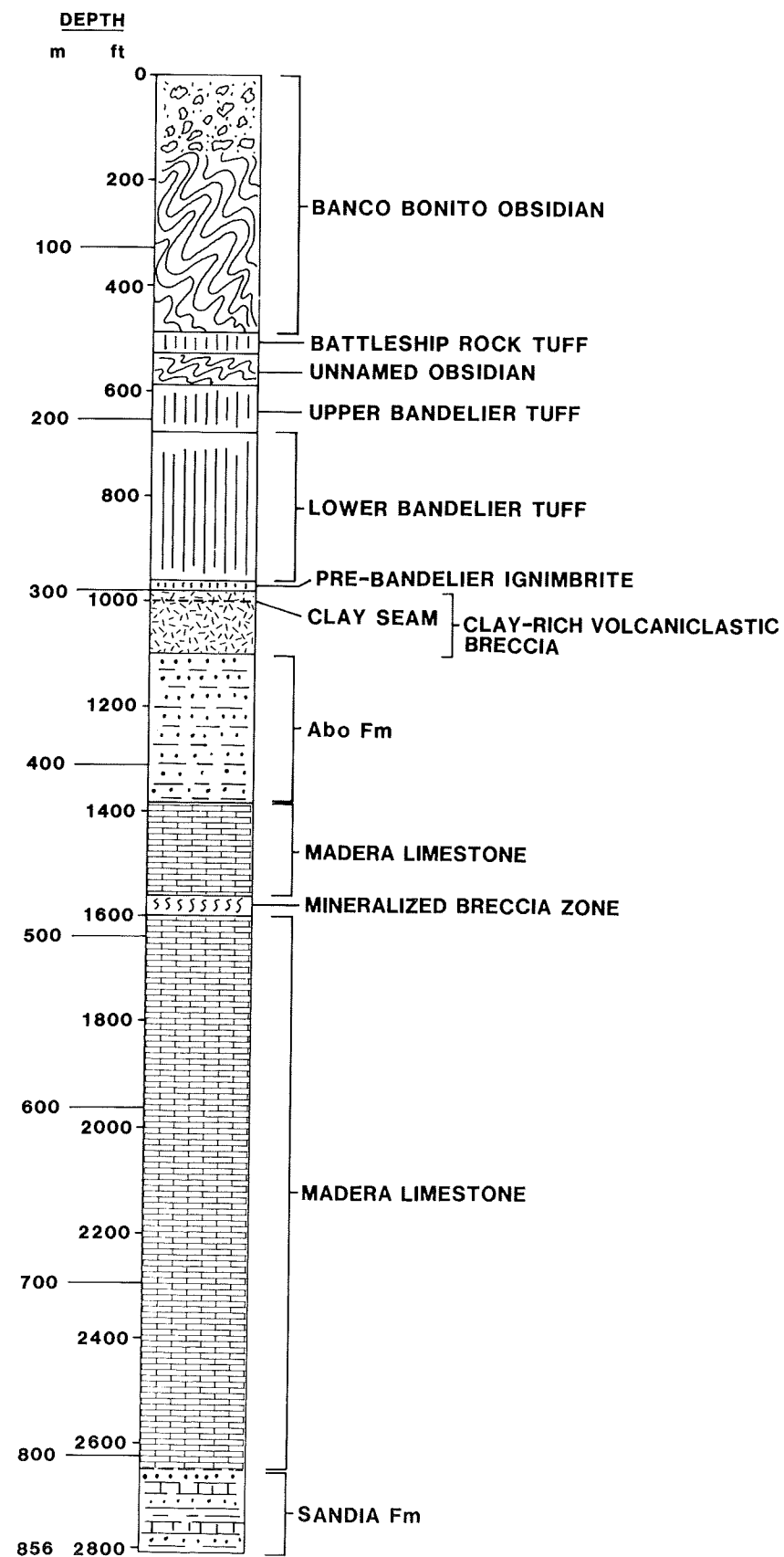

Fig. 2.
Core hole VC-1 stratigraphy.

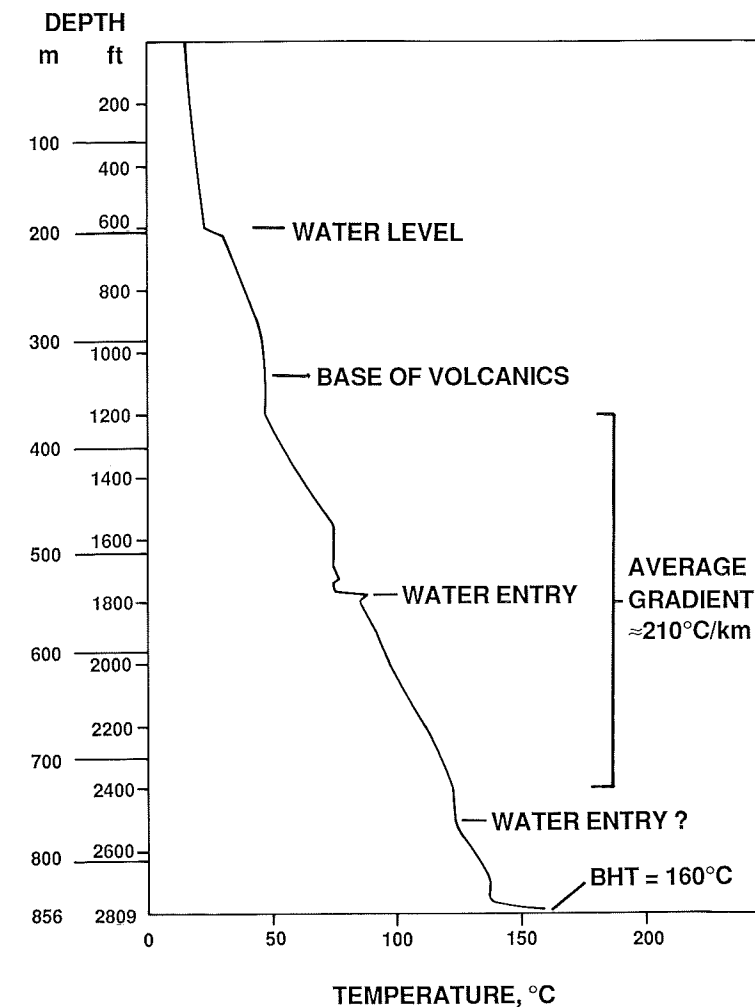

Fig. 3.
VC-1 Temperature gradient (24 h after completion).

caldera by Swanberg (1983). The thermal fluids encountered at the intersection of the ring-fracture zone and the JFZ may be part of a hydrothermal plume that leaks down the JFZ and adjacent strata toward Jemez Springs and Soda Dam (Trainer 1975; Goff et al. 1981).

Mineralization is most intense along shear zones and in brecciated Madera Limestone. Although the alteration zones have not been examined in detail, they consist primarily of clays, calcite, pyrite, quartz, and chlorite. Fluids were sampled in the fall of 1985 as a collaborative effort among several investigators.

The VC-1 core and the cased borehole are available for scientific investigations at least until 1989.

II. HISTORICAL DEVELOPMENTS

There has been significant geologic and hydrogeochemical research on Valles Caldera and the Jemez Mountains (Smith and Bailey 1968; Doell et al. 1968; Goff and Grigsby 1982), and overviews of the geothermal systems of Valles Caldera are available (Laughlin 1981; Heiken and Goff 1983). A report by Goff and Waters (1980) relates the Rio Grande rift and associated igneous activity to the Valles Caldera thermal regime and suggests potential targets for scientific drilling. The Hot Dry Rock geothermal development project has been active on the western flank of the Valles Caldera (Tester 1979; Rowley 1984). This effort was preceded by shallow heat flow holes drilled outside Valles Caldera on the east, south, and west flanks. Five deep boreholes were then drilled into Precambrian formations for the Hot Dry Rock Project west of the Valles Caldera rim (Fig. 4) (Laughlin et al. 1983; Rowley 1984). Union Oil Company of California and other geothermal companies have drilled approximately 30 deep geothermal wells inside Valles Caldera in search of superheated waters (Dondanville 1978).

The current phase of CSDP research drilling at Valles Caldera started with the Valles Caldera Workshop in 1982 (Heiken et al. 1983). Table I records the major steps and activities for the two years required to formulate the scientific objectives and plan, prepare a proposal, and then implement the plan.

One notable area of effort as indicated on Table I was permitting. At the time of the Valles Caldera Workshop in October 1982, it was certain that the core hole target identified by workshop participants, the vent of the Banco Bonito flow, could be drilled on the private land owned by the Baca Land and Cattle Co. This property had, at that time, a geothermal exploration and development lease held by the Union Oil Company of California. Requests for permits to drill on the Baca location needed to be approved first by Union. This permission did not materialize until late April 1984, although the request was forwarded in November 1983. It was then learned that the landowner (Baca Land and Cattle Co.) was reluctant to proceed with the project. Fortunately an alternate site on US Department of Agriculture/Forest Service land had been selected as a contingency. Once a core hole permit for this alternate Banco Bonito site was granted July 3, 1984, the coring drill rig contracting proceeded without further delay.

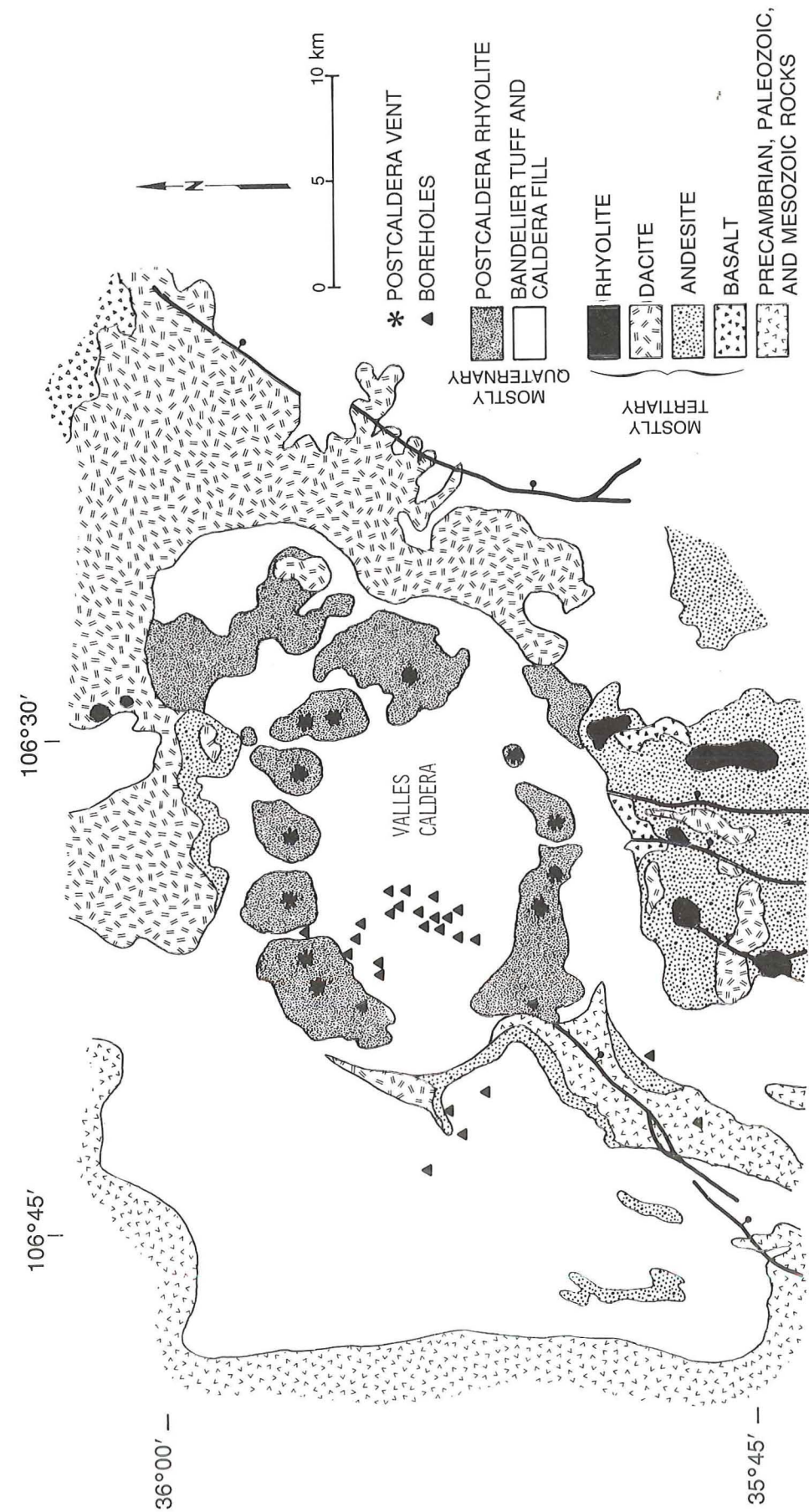

Fig. 4. Generalized geologic map of Valles Caldera area with exploration boreholes and VC-1 site shown. Figure 11 shows detail of the area around VC-1 within the dashed box (geology from Smith et al. 1970 and Gardner 1985).

TABLE I
HISTORICAL DEVELOPMENT OF THE FIRST VALLES CALDERA, CSDP - THERMAL REGIMES
RESEARCH CORING PROJECT, VC-1

Date(s)	Activity
October 1982	Valles Caldera Workshop (Heiken et al. 1983). Choose Banco Bonito obsidian-southwest ring fracture as high priority site.
November 1982	Initiate preparation of "Four-Laboratory" proposal. Begin discussions with Union Oil Co. and landowner for access to first Banco Bonito site.
December 1982	Informal discussions with core rig contractors; decided on top-to-bottom core; preliminary cost estimates.
December 1982	Union Oil Co. gives verbal approval to core first Banco Bonito site.
March-April 1983	Submit "Four-Lab" proposal to DOE/OBES.
October 1983	"Four-Lab" proposal approved by DOE/OBES.
November 1983	Alert Los Alamos Support Groups (legal, safety, fire protection, procurement, environmental surveillance, etc.).
January-February 1984	Informal discussions with core rig contractors. Determine interest and estimated costs.
February 1984	Initiate discussion with US Forest Service for second Banco Bonito site.
March 11, 1984	DOE Davis-Bacon determination
April 1984	US DOE, DOI (USGS), & NSF accord signed.
April 1984	Forward draft procurement package (competitive solicitation with selection based on technical evaluation).
April 10, 1984	"Four-Lab" Principal Investigators and DOE/OBES approve second Banco Bonito site.
April 20, 1984	Submit final procurement package.
April 26, 1984	Union Oil approves coring first Banco Bonito site.
June 1984	On-site management team, core curation procedure, and site geologist well sitters team organized.
June 7, 1984	Action Description Memorandum (ADM) approved by Los Alamos and DOE.
June 8, 1984	Baca landowner finally indicates lack of immediate interest in Banco Bonito project.
June 20, 1984	Responses to core rig RFQ (request for quotations) received and evaluated.
July 3, 1984	Forest Service permit approved.
July 20, 1984	Core rig subcontract initiated with Tonto Drilling Services (Salt Lake City, Utah).
July 31, 1984	Rig arrives at VC-1 site.
September 3, 1984	Rig released at 1:15 a.m., T.D. at 2809 ft.
October 15-18, 1984	Workshop on recent research at Valles Caldera.
December 3-7, 1984	VC-1 preliminary results presented at Fall Am. Geophys. Union Meeting, San Francisco (Geotimes, Feb. 1985).

The slightly more than one month of core drilling, July 31 through September 3, 1984, required only about 1/24 (8%) of the project's elapsed time up to September 1984, but it is anticipated that investigations of the core and borehole data will yield significant scientific results during the next five years (Fig. 5).

III. CORE REQUIREMENTS AND RIG SPECIFICATIONS AND PROCUREMENT

The original core hole plan is shown in Fig. 6. Continuous core, to a depth of 760 m (2500 ft), was required in a potentially complex volcanic section, with the likelihood of encountering hot (~150°C) hydrothermal fluids. Therefore, in contracting with a drilling company, the major considerations were demonstrated experience with high-temperature blowout-prevention (BOP) equipment, high-temperature cementing, and geothermal exploration-oriented coring rig operations. Informal inquiries were made of potential core drilling rig contractors and their former clients. Technical evaluation

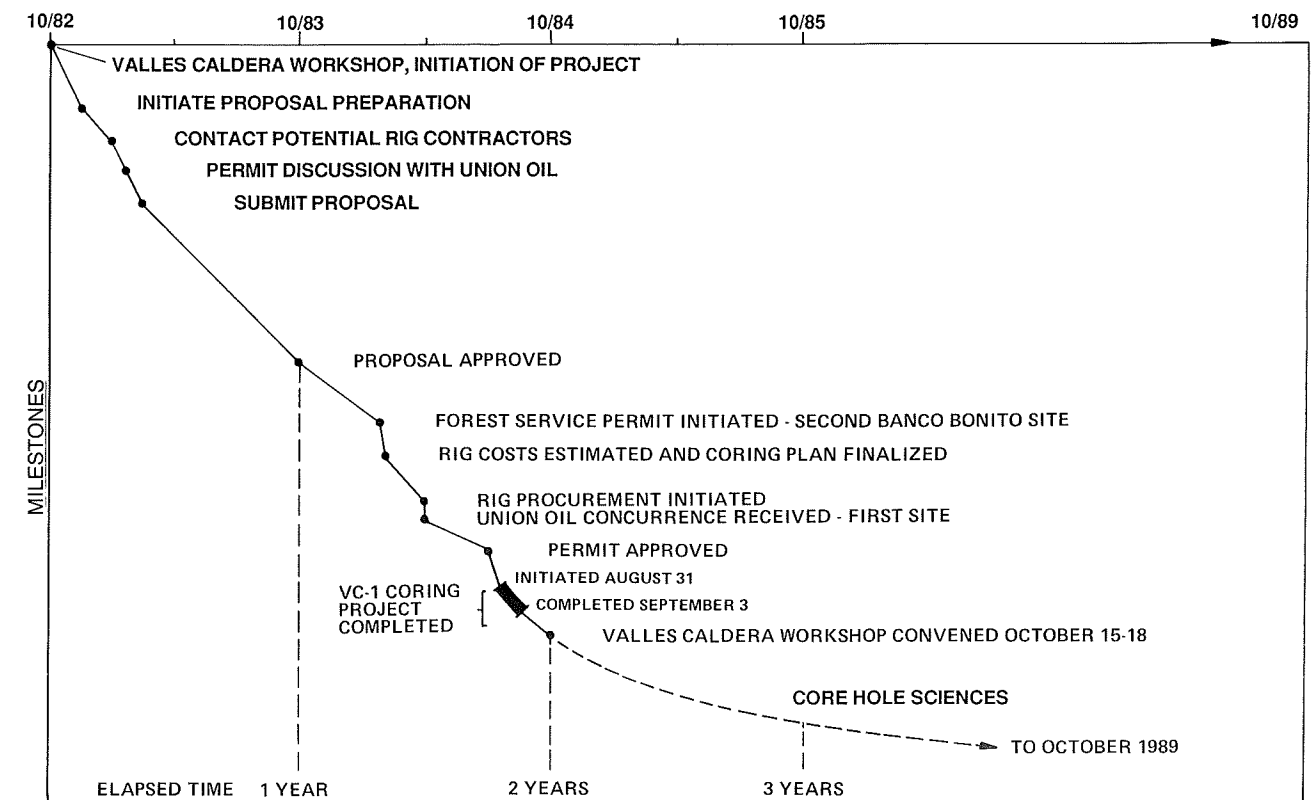

Fig. 5.
Time line of VC-1 milestones. Research on VC-1 samples and in the borehole will continue for at least five years after completion of coring.

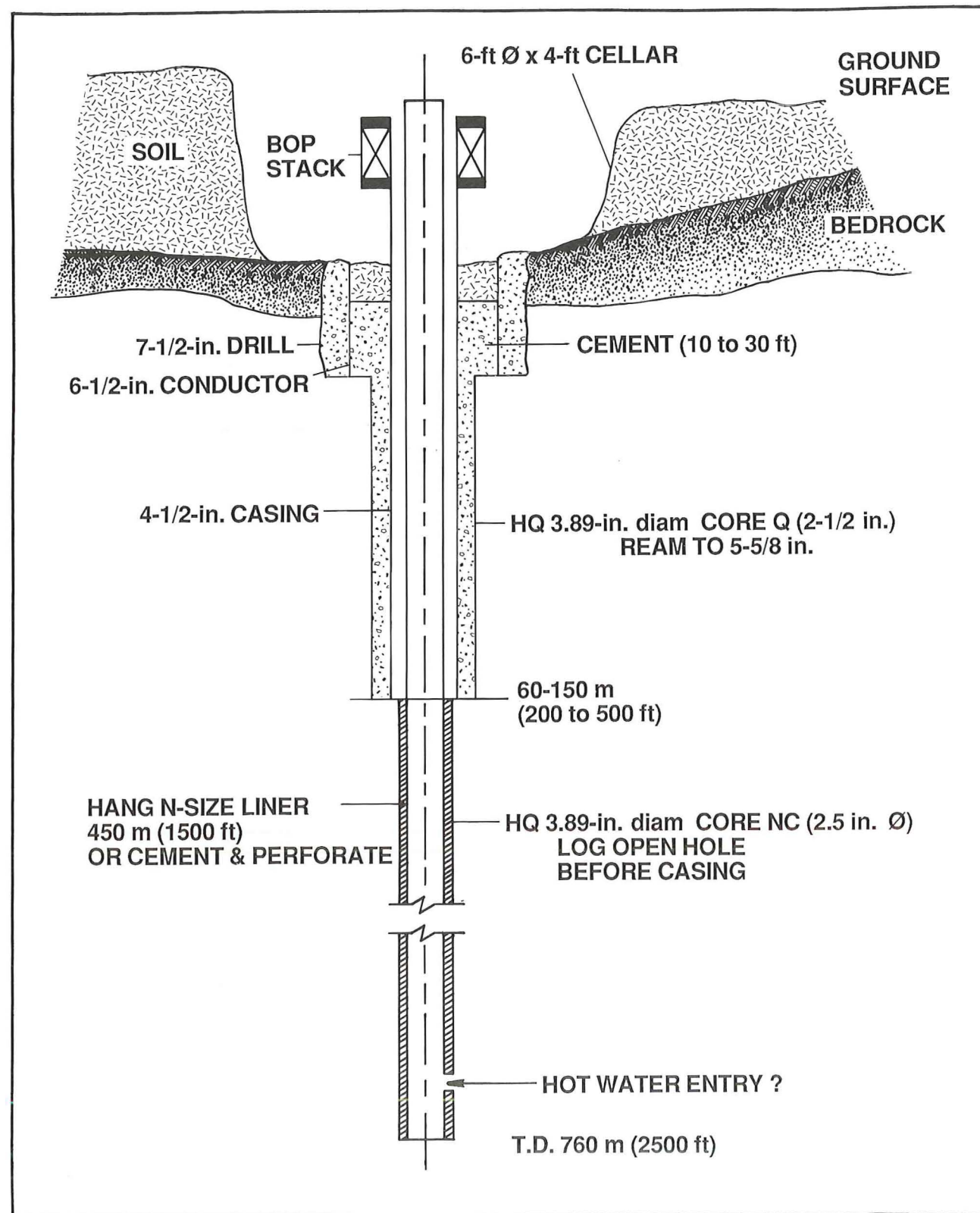

Fig. 6.
Core hole plan for VC-1.

criteria were prepared and then used to judge the responses to the competitive request for proposals that was sent out in June 1984. The four principal criteria were

- A written statement demonstrating the capabilities of the rig contractor to successfully plan and perform the required high-quality wireline coring operations in a high-temperature volcanic environment.
- A written description of the capabilities and experience of the rig contractor with high-temperature BOP equipment, high-temperature cements and cementing procedures, and the required coring operations in a geothermal area.
- Written résumés and statements of the demonstrated qualifications and experience of the personnel proposed to perform the required wireline coring operations.
- Capability, adequacy, and suitability of the proposed drilling equipment, determined by detailed equipment lists presented by the bidder.

The rig equipment specifications of the subcontract were general in nature and were stated in terms of the minimum requirements of depth, drill rod (drill string) handling capability, and required supporting equipment, such as a completely enclosed drilling fluid system (i.e., a surface mud tank, rather than a mud pit or sump) as required by the Forest Service permit at the alternate site.

The drilling contractor was selected on June 20, 1984, followed by issuance of an order to proceed on July 20, 1984. The specifications, equipment, and features of the selected rig are recorded in Table II.

IV. SUMMARY OF CORING OPERATIONS

A. Site Preparation and Layout

The core rig (Tonto Drilling Services, Tonto Drill No. 1) was mobilized to the VC-1 alternate site on July 31, 1984 (Fig. 7). The final VC-1 site layout, shown in Fig. 8, was an 18- by 28-m (60- x 90-ft) rectangular area meeting the constraints of the Forest Service permit. The 38-m³ (10,000-gal.) water tank, centrally located rig, BOP control module, core trays, and operations trailer were arranged as shown. The site preparation included the excavation of a hole needed to emplace a 2-m-diam x 1.2-m-long (6-ft-diam x 4-ft-long) culvert set flush with the ground surface at the center of the site

TABLE II

TONTO DRILL NO. 1 CORE RIG SPECIFICATIONS AND FEATURES

SPECIFICATIONS

Dimensions:

Length: 33 ft, 6 in.
 Width: 10 ft, 0 in.
 Height: 13 ft, 6 in.
 Weight: 41,000 lb

Mast Assembly:

Pull capacity: 20 ft
 Angle range: -90° to -45°

Main Hoist:

Bare drum pull: 25,050 lb
 Max. line speed: 142 ft/min
 Power-up/power-down operation
 Fail-safe hydraulic brake

Feed System: (chain drive)

Stroke: 11 ft
 Lift capacity: 40,000 lb
 Thrust capacity: 25,000 lb
 Feed rate: 0-30 ft/min

Drill Head:

Speed range: 0-1200 RPM
 Torque range: 0-3600 ft/lb
 Hydraulic chuck: 3-5/8-in. I.D.

Footclamp:

Hydraulic mast base-mounted
 HW casing/PQ rod capacity

Hydraulic System:

3 pump box c/w driveline transfer case
 100-gal. tank with oil cooler
 5 suction/return filters
 Three 10- μ m high-pressure filters

FEATURES:

- Integrated system
- Ease of mobilization
- Shortened tear-down and set-up time
- Completely enclosed mud system for lower costs and reduced environmental impact
- Long stroke for increased production
- Improved core recovery and bit life
- On-site parts and supplies
- High torque for rotary drilling
- Self-contained and enclosed work area
- Noise level below 110 dB.

Power:

Cummins 290-h.p. turbodiesel
 Driller start/stop/RPM control
 All gauges at driller station
 Fuel usage approx. 60 gal./day

Wireline Hoist:

1800-lb. bare drum pull
 0-1100 ft/min line speed
 Power-up/power-down operation
 4000-ft capacity

Electrical System:

12-V system c/w emergency lighting
 110-V 7.5-kw hydraulic generator
 Interior explosion-proof lighting
 Exterior 500-W quartz halogen rig lights

Mud System:

Tailgate mounted self-contained
 1000-gal. capacity
 Mixing tank c/w jet mixer
 NL Baroid cone desilter
 3-stage settling tank

Circulating System:

Bean 50 pump
 Variable hydraulic control



Fig. 7.
 Tonto Drill No. 1 arriving at VC-1, July 31, 1984.



Fig. 10.

General view of the VC-1 site from the southwest. Note the 10,000-gal. water tank and protected trees on the left. The BOP controls are behind the small tree in the lower right. The mud tank is between the coring rig and the fluid additive supplies (under tarp).

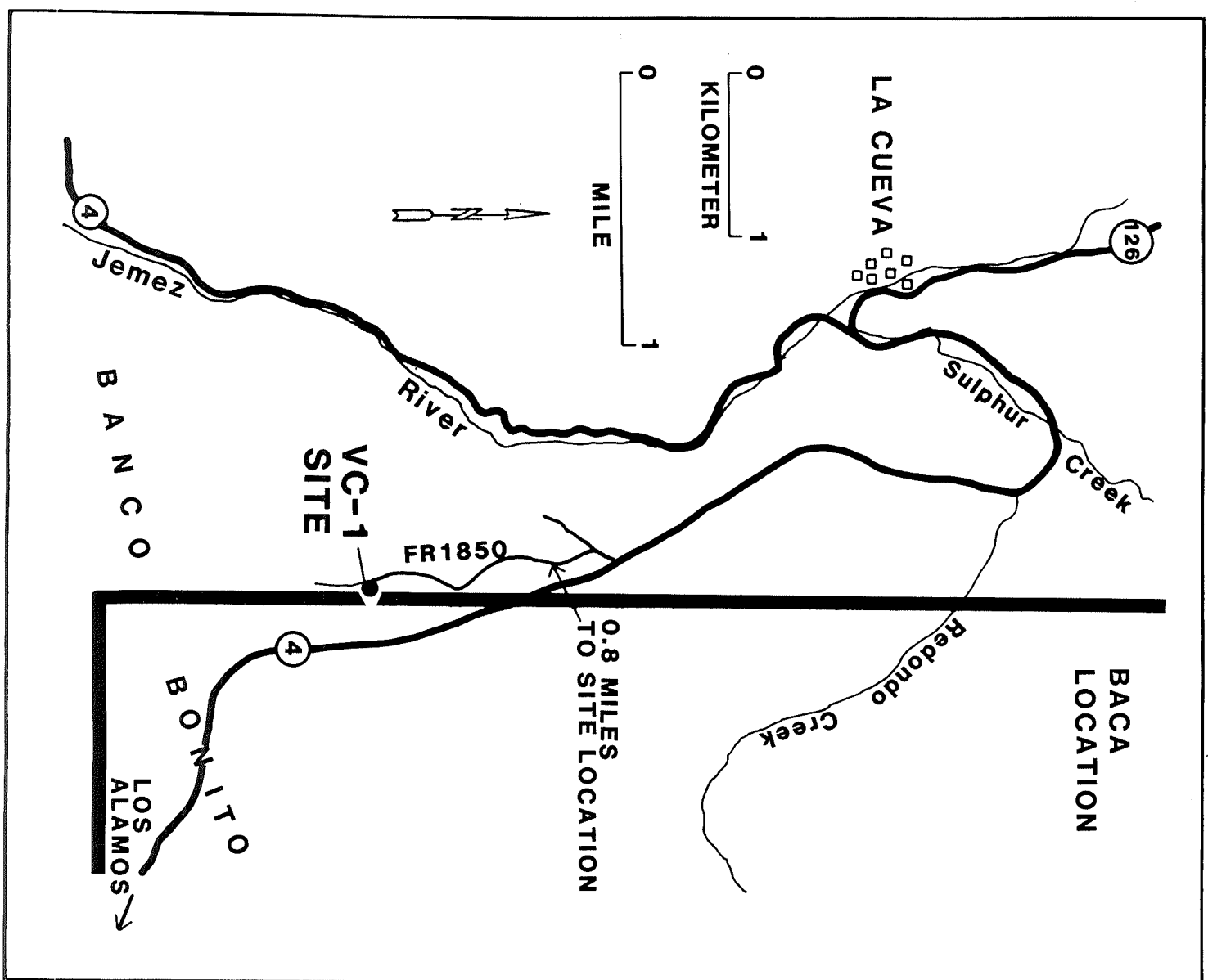

Fig. 11.
VC-1 site location map (see Fig. 4).

drainage and to level and grade the road to minimize potential damage and rutting from heavy truck traffic.

To preserve the forest floor at the site no leveling or grading were performed. Two tarps were laid on the ground under the core rig, Fig. 8, and the rig was leveled with jacks and blocking.

Other measures to minimize the environmental impact were

- o A fire-monitoring and suppression plan that included inspected and approved spark arresters.
- o Road maintenance and access restrictions.
- o Exclusion of sanitary pits, nearby camping by rig or geological personnel, and trash accumulation.
- o Plank guards to protect all nearby trees, Fig. 10.
- o Observance of geothermal operation orders (GR00-19), primarily by properly cementing the 4-1/2-in. casing and installing a suitable blowout-preventer stack and controls.
- o An ambient noise level maximum of 110 dB. (The rig was actually very quiet with its operating noise level measured at 84 dB. Indeed, one could easily talk on the rig floor.)

B. Drilling Operations Summary and Daily History

Drilling operations are summarized in Table III and Fig. 12. The target depth (760 m) was reached on Day 28 of operations. The average advance rate was 25.9 m/day (85.1 ft/day) for the 33 days of rig operations. Various average advance rates and core bit performance are summarized in Table IV.

The core hole was started on August 1, Day 0. The surface hole was drilled in soil with a three-cone, 22.2-cm-diam (8-3/4-in.) button bit to a depth of 3.0 m (10 ft) below the cellar floor. At that depth suitable hard rock was encountered to set and cement in the 16.5 x 15.2-cm (6-1/2 x 6-in.) surface casing. The cement was allowed to cure for 10 hours and then drilled out with a 14.3-cm-diam (5-5/8-in.), three-cone button bit. The rotating head with fluid circulation discharge line was rigged up.

On Day 1 of operations the rig was set up for HQ-size* coring with a 1.5-m-long (5-ft) core barrel and core tube. Coring commenced in very fractured rock. Circulation was lost immediately, and no drilling fluid returns were recovered down to a depth of 9.1 m (30 ft), where solid rock was

*HQ core bit size is 3.82-in. O.D. by 2.50-in. core diameter; see Table IV.

TABLE III
VALLES CALDERA CSDP THERMAL REGIMES - VALLES CALDERA NO. 1
SUMMARY OF RIG ACTIVITIES

(July 31 - September 3, 1984)

Date	Days Since Spud (Drilling Days)	Depth ft (m)	Day's Progress ft (m)	Core Run Number	Range ^a % Rec'y.	Bit Size (in.)	Remarks
July 31, 1984	-1	0	0	0	NA	--	Tonto Drill No. 1 arrived at VC-1 site.
August 1, 1984	0 (Spud Day)	10 (3.0)	10 (3.0)	0	NA	8-3/4 in.	Drilled with three-cone 8-3/4-in. bit to 10 ft; set 6-1/2-in. casing; waited on cement; drilled out cement with 5-5/8-in. three-cone bit.
2	1 (1)	146 (44.5)	136 (41.5)	1-41	14-98	HQ (3.832x2.50)	Began HQ coring with 5-ft barrel and severe lost circulation.
3	2 (2)	277 (84.4)	131 (39.9)	42-69	94-100	HQ	Cored in glassy obsidian. Replaced core bit at 242 ft depth, bit No. 2.
4	3 (3)	400 (121.9)	123 (37.5)	70-94	89-100	HQ	Cored and then reamed hole with three-cone 5-5/8-in. bit. Hole caved at 121 ft.
5	4	400 (121.9)	0	0	NA	5-5/8 in.	Reamed to 400 ft with 5-5/8-in. bit and ran geophysical logs; hole caved at 122 ft. Replaced bit at 400 ft depth, bit No. 3.
6	5	400 (121.9)	0	0	NA		Completed logging to 122 ft. Ran HWL casing to 400 ft; waited on cement and installed BOP.
7	6 (4)	507 (154.5)	106 (32.3)	95-116	90-100	HQ	Completed BOP installation; drilled cement. Resumed coring. Stuck rock at 472 ft; lost circulation at 488 ft depth at obsidian - tuff contact.
8	7 (5)	698 (212.8)	191 (58.2)	117-140	83-100	HQ	Lost circulation. Cored run No. 121, which was first 10-ft barrel.
9	8 (6)	917 (279.5)	219 (66.8)	141-162	89-100	HQ	Temperatures measured at 847 and 897 ft were 28°C (82°F).
10	9 (7)	1016 (309.7)	99 (30.2)	163-174	16-100	HQ	Replaced bit (No. 4) & greased rods. Stuck core tube in volcanic breccia at 1016 ft and stuck rods at 902 ft.
11	10	1016 (309.7)	0	NA	NA	HQ	Decided to cement in HQ rods and reduce bit size.
12	11	1016 (309.7)	0	NA	NA		First cement placement was attempted but cement did not set up around HQ bit.
13	12	1016 (309.7)	0	NA	NA	HQ	Recemented hole and HQ bit, N- to B-size cement string transition bridged.
14	13	1016 (309.7)	0	NA	NA	NQ (3.03x1.875)	NQ core bit used (No. 5) to drill through HQ bit and cored cement 902 to 968 ft. Lost circulation at 932 ft.
15	14 (8)	1072 (326.7)	56 (17.1)	175-181	91-100	NQ	Cored cement to 1016 ft; cased formation swelled with clay. Rig had mechanical problem with hoist.
16	15 (9)	1082 (329.8)	10 (3.0)	182	98	NQ	Repaired rig.
17	16 (10)	1146 (349.3)	64 (19.5)	183-189	76-100	NQ	Completed rig repair and installed N-size rubber seats in BOP. Cored in red swelling clay of Abo Fm.

NA = Not applicable.
See Fig. 17 for a detailed plot of core recovery as a function of depth.

TABLE III (cont)

Date	Days Since Spud (Drilling Days)	Depth ft (m)	Day's Progress ft (m)	Core Run Number	Range ^a % Rec'y.	Bit Size (in.)	Remarks
18	17 (11)	1250 (381.0)	104 (31.7)	190-200	49-100	NQ	Cored red swelling clay; water level was at 200 ft. Temperature at 1185 ft was 34°C (93°F).
19	18 (12)	1378 (420.0)	128 (39.0)	201-214	86-100	NQ	Temperature at 1360 ft was 49°C (120°F).
20	19 (13)	1531 (466.6)	153 (46.6)	215-230	87-100	NQ	Entered and cored Madera limestone at 1384 ft. Temperature at 1410 ft was 47°C (117°F).
21	20 (14)	1602 (488.3)	71 (21.6)	231-240	35-100	NQ	Pulled rods and made three oriented core runs.
22	21 (15)	1732 (527.9)	130 (39.6)	241-255	74-100	NQ	Temperature was 69°C (156°F) at 1680 ft. Overshot broke, retrieved and repaired.
23	22 (16)	1871 (570.3)	140 (42.7)	256-268	97-100	NQ	Cored hard limestone.
24	23 (17)	2011 (613.0)	140 (42.7)	269-282	93-100	NQ	Temperature at 1981 ft was 87°C (189°F).
25	24 (18)	2141 (652.6)	130 (89.6)	283-295	100	NQ	Temperature at 2051 ft was 102°C (216°F).
26	25 (19)	2271 (692.2)	130 (39.6)	296-308	95-100	NQ	Cored limestone, temperature at 2291 ft was 117°C (242°F).
27	26 (20)	2391 (728.8)	120 (36.6)	309-321	97-100	NQ	Lost circulation at 2380 ft.
28	27 (21)	2510 (765.0)	130 (39.6)	322-334	95-100	NQ	Temperature at 2510 ft was 130°C (266°F). Decided to continue project and attempt to tag Precambrian granite.
29	28 (22)	2624 (799.8)	114 (38.7)	335-345	91-100	NQ	Encountered hard rock with broken, blocky structure.
30	29 (23)	2726 (830.4)	102 (31.1)	346-356	83-100	NQ	Rods stuck and lost circulation zone encountered at 2719 ft.
31	30 (24)	2809 (856.2)	84 (25.6)	356-367	85-100	NQ	Cored in sandstone and shale at 2781 ft, temperature 98°C (218°F), rods stuck for 3 h. Core was brittle and sticky clay. Hole caving and rods stuck in shale at 2809 ft. Decided to terminate coring operations.
September 1984							
1	31	2809 (856.2)	0	NA	NA	NQ	Pulled N-rods and prepared for open hole logging. Hole caved and blocked at 1031 ft. Washed to 2750 ft and logged while pulling rods.
2	32	2809 (856.2)	0	NA	NA	NQ	Completed logging; ran casing cutter to 360 ft and retrieved H-rods. Ran N-rod liner to 2803 ft with NQ bit on bottom and 13-ft core barrel. Pumped a plug to bottom; filled casing with fresh water. Rig released at 1315 h and left site.
3	33	2809 (856.2)	NA	NA	NA	NA	Made up wellhead with gate valve, choke and vent valve manifold. Cleaned site and loaded remaining equipment.

^aNA = Not applicable.

^bSee Fig. 17 for a detailed plot of core recovery as a function of depth.

^cTotal nondrilling days were 10; see Fig. 16 for percentage summary of activities as function of total.

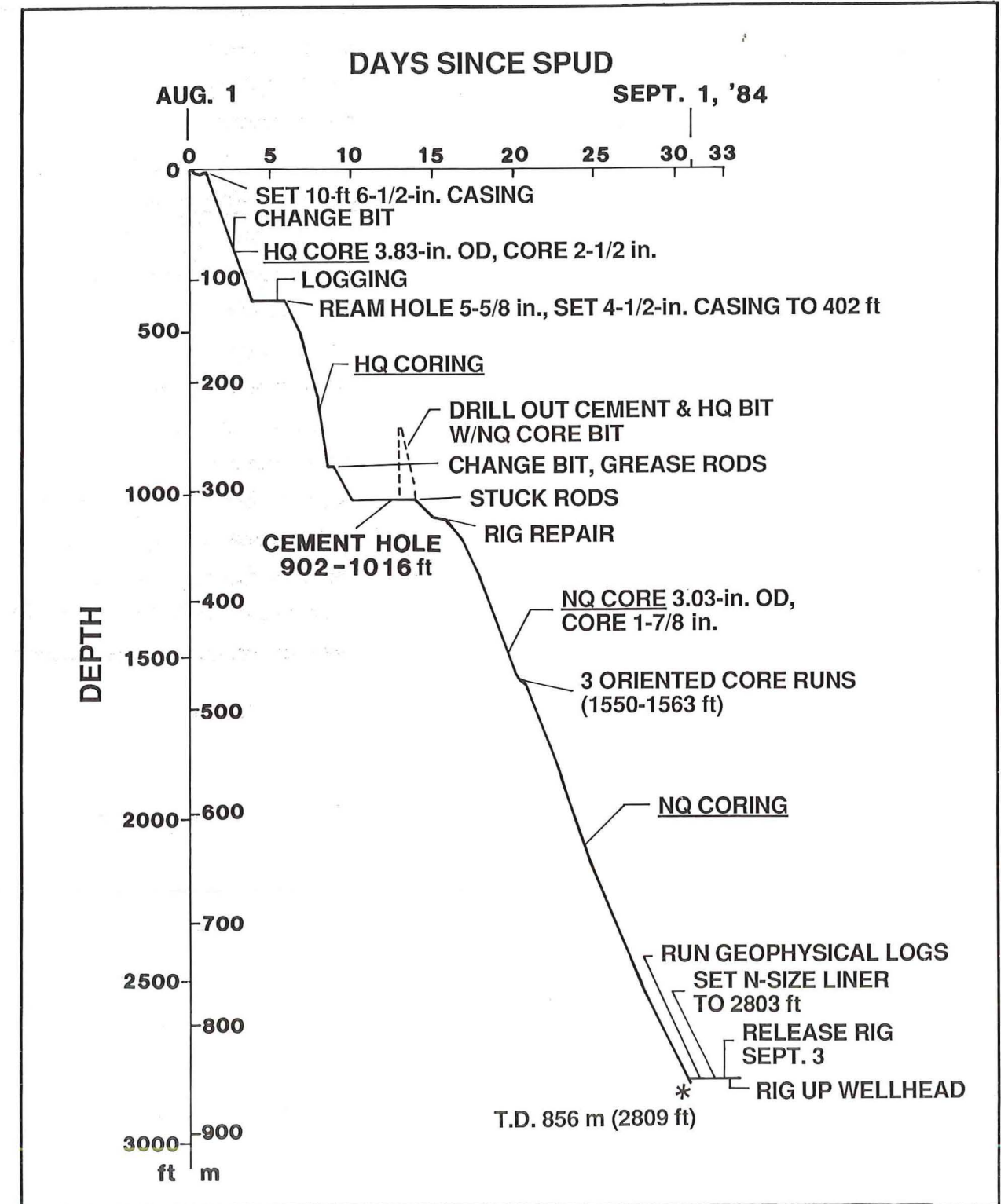

Fig. 12. Coring operations history for VC-1.

TABLE IV

CORE BIT RECORD SUMMARY VC-1

Bit No.	Interval Cored (ft)	Bit Size ^a	Bit O.D. (in.) ^b	Core Diameter (in.)
(1)	10 - 242	HQ	3.83	2-3/4
(2)	242 - 400	"	"	"
(3)	400 - 917	"	"	"
(4)	917 - 1016	"	"	"
(5) ^c	1016 - 2809	NQ	3.03	1-7/8

^a Longyear - Green Series 1, for medium hard, abrasive rock; all were of diamond-impregnated matrix type.

^b The 3.83- and 3.03-in. O.D. bits are oversize; conventional bit diameters for H and N are 3.782 and 2.98 in., respectively.

^c Bit was about 2/3 dulled and had drilled out previous HQ bit.

reached. At the end of the first day, a depth of 44.5 m (146 ft) had been achieved, and 41 core runs were completed, although all runs were short because fractured rock jammed the core barrel. Late on Day 3 a very glassy zone in the rhyolite flow was encountered; the rods were pulled, and the core bit was replaced at a depth of 73.8 m (242 ft). Coring with the HQ bit and 1.5 m (5 ft) core tube continued through Day 3 down to the first casing point depth of 121.9 m (400 ft) during which core runs 70-94 were completed. This section of hole was reamed with a 5-5/8-in.-diam button bit to increase the hole diameter. Reaming was completed during Day 5, and geophysical logging was attempted. Due to extensive caving and blockage of the hole at 37.2 m (122 ft), logging was successfully accomplished only above this depth. The 11.4 x 10.2-cm (4-1/2 x 4-in.) casing was run into 122.5 m (402 ft) depth, set, and cemented in place. This string of casing formed the structural tie for mounting of the BOP, and the casing was securely and completely cemented up to the bottom of the cellar. Late on Day 5, after cementing had been completed successfully and while the cement was hardening, the BOP installation on the 4-1/2-in. casing was begun. On Day 6, the BOP installation was completed, and the cement was drilled out with an HQ core bit. HQ coring commenced again on Day 6. Below the 4-1/2-in. casing, circulation to the surface was briefly established. The core rods (drill pipe or bit) were stuck in the hole briefly at 143.9 m (472 ft), and circulation was lost at 148.7 m

(488 ft) in a thin pumiceous zone at the contact between rhyolite and underlying tuff. By the end of Day 7, a depth of 212.8 m (698 ft) had been achieved, and 140 core runs had been completed. During Day 7, with core run 121, at a depth of 165.2 m (542 ft), the use of a 3.05-m (10-ft) core barrel inner tube was initiated. This system was used for the remainder of the coring operations in VC-1.

Coring proceeded on Days 8 and 9, and circulation continued to be completely lost. At 309.7 m (1016 ft), after core run 174, the core tube became stuck in the barrel because of clay in the volcanic breccia. After several hours of work, the core tube could not be freed, so it was decided to pull the entire drill string from the hole and take the core tube and barrel apart. However, the string became stuck solidly after it was pulled only 34.7 m (114 ft) off bottom. It was not possible to move the rods up or down with the bit at a depth of 274.9 m (902 ft). The drilling assembly was firmly planted. The core tube was finally fished from the core barrel by using a special adapter and the more powerful main hoist.

It was then decided to cement below and around the HQ bit and to drill through the bit with an NQ core bit. Three cementing attempts were necessary to successfully accomplish this task. A special subassembly of B- and N-size rods was fabricated so that the cement could be placed below and around the stock H-size bit. The first cement job bridged in the BQ/NQ transition subassembly, and the second left a 7.5-cm (3-in.) gap below the HQ bit. It was necessary to assure that the bit and shell were firmly cemented in place, so a third cement job was performed. On Day 13, after waiting for the cement of the final stage to harden, cement was cored out of the H-rods, and the HQ bit was drilled through. Coring of cement proceeded with a very light load on the bit to avoid sidetracking out of the cement. At the end of Day 13 a depth of 295.0 m (968 ft) had been attained. On Day 14 coring resumed to 326.7 m (1072 ft), and core runs 175 through 181 were completed. Rig problems, which developed in the hydraulic ram of the hoist late in Day 14, required all of Day 15 and part of Day 16 to repair; only one core run (No. 182) was completed.

Following completion of repairs to the rig on Day 16, NQ coring continued steadily through Day 20; core runs 183 through 240 were completed to a depth of 488.3 m (1602 ft).

On Day 20 three oriented core runs were made from 472 to 476 m (1550 to 1563 ft), and on-site in situ stress and relaxation determinations were

performed on the core by separate teams from Sandia and Los Alamos (Dey et al. 1984).

Coring continued steadily from Day 21 through 29. At 829 m (2719 ft) the rods were stuck briefly, but were pulled loose. Core runs 241 through 356, in relatively hard limestone, were completed with excellent recovery. Day 30 (August 31, 1984) saw the coring go to 856.2 m (2809 ft), where a very brittle and sticky clay was encountered. Severe caving occurred in this zone and the rods became stuck, but they were quickly pulled loose.

Core runs 357 through 367 were completed on Day 30. Due to the extreme risk of continuing NQ coring in this unstable, caving, clayey formation, it was decided to terminate coring, pull out of the hole, and attempt the planned open hole geophysical logging. The bottom hole section (the N-bit and rods) could have been cemented in and coring continued with B-size bit and rods. However, this work would have required several days and, since the project was nearing the budget limit and all major objectives had been more than accomplished, coring operations were terminated.

Downhole temperatures were measured about twice a day from the time the HQ coring began. At 847.6 m (2781 ft) the temperature was 98°C (218°F), much less than that measured during logging (Fig. 3). This lower temperature may have been related to a large quantity of cool water pumped in a lost circulation zone at 828.8 m (2719 ft) depth.

Days 31 and 32 were spent running geophysical logs. Swelling and blocking of the core hole at about 314 to 381 m (1250 ft) made it necessary to recore portions of the hole and run the logging tools in the open hole sections below suspended rods.

The hole was completed on Day 32 with the running of the dulled NQ core bit and casing to 854.4 m (2803 ft), pumping a cement slurry to bottom followed by a plug, and then filling the N-rods with fresh water. Figure 13 shows the final configuration of the hole. The rig was released at 13:15, September 3, 1984, Day 32. Day 33 was used to rig down equipment, install a 4-in. gate valve on the wellhead (Figs. 14 and 15), and load equipment. By the afternoon of September 4, 1984, only filling the cellar with gravel and reseeding and restoring the site were left to be accomplished.

Completing the 2.375-in.-I.D. N-rod liner will allow future access to the hole for hydrologic tests and leaves open the possibility of future coring with BQ-size coring bits and rods through the NQ bit cemented on bottom. It

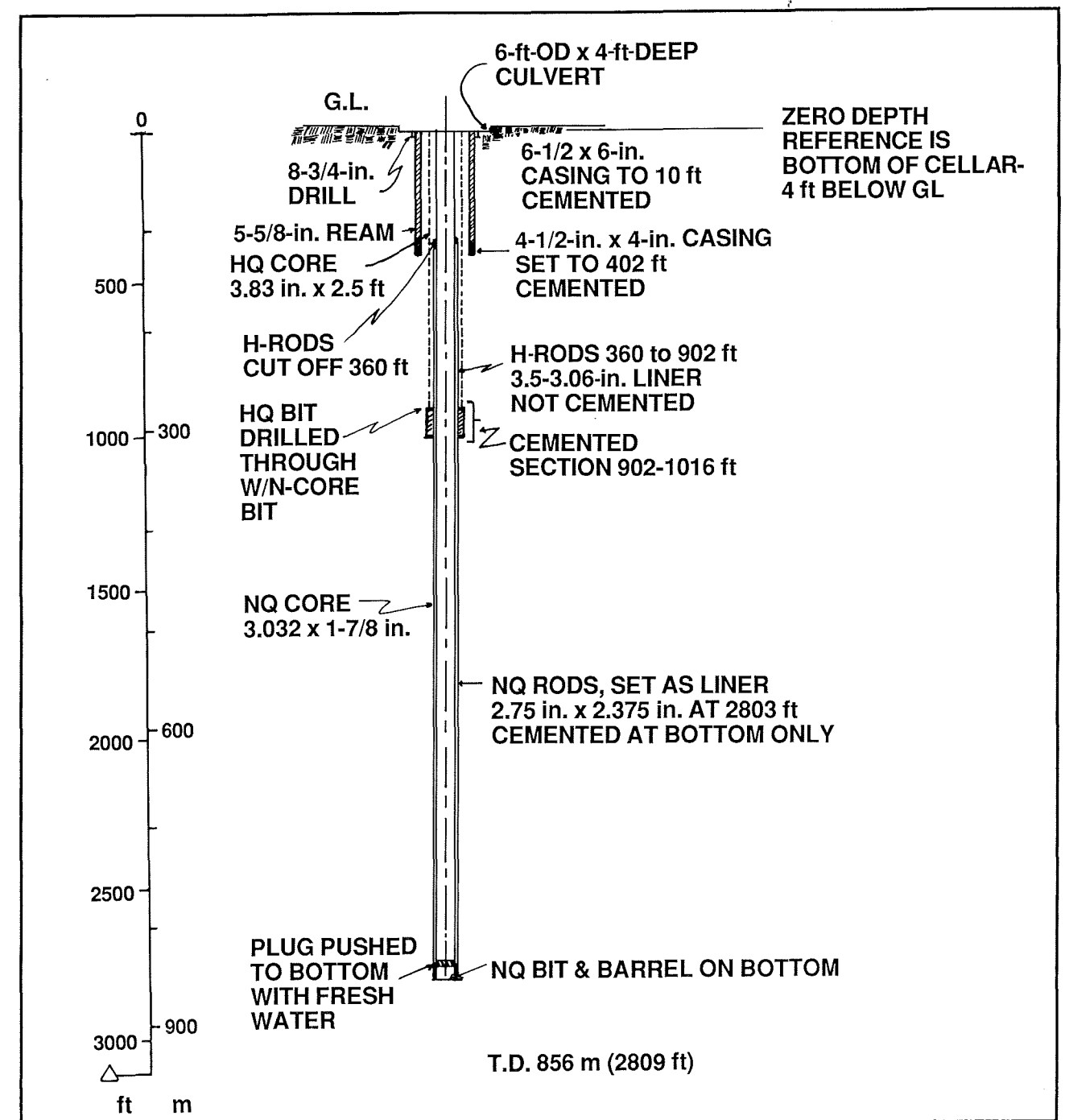

Fig. 13.
Actual (as-built) VC-1 configuration.

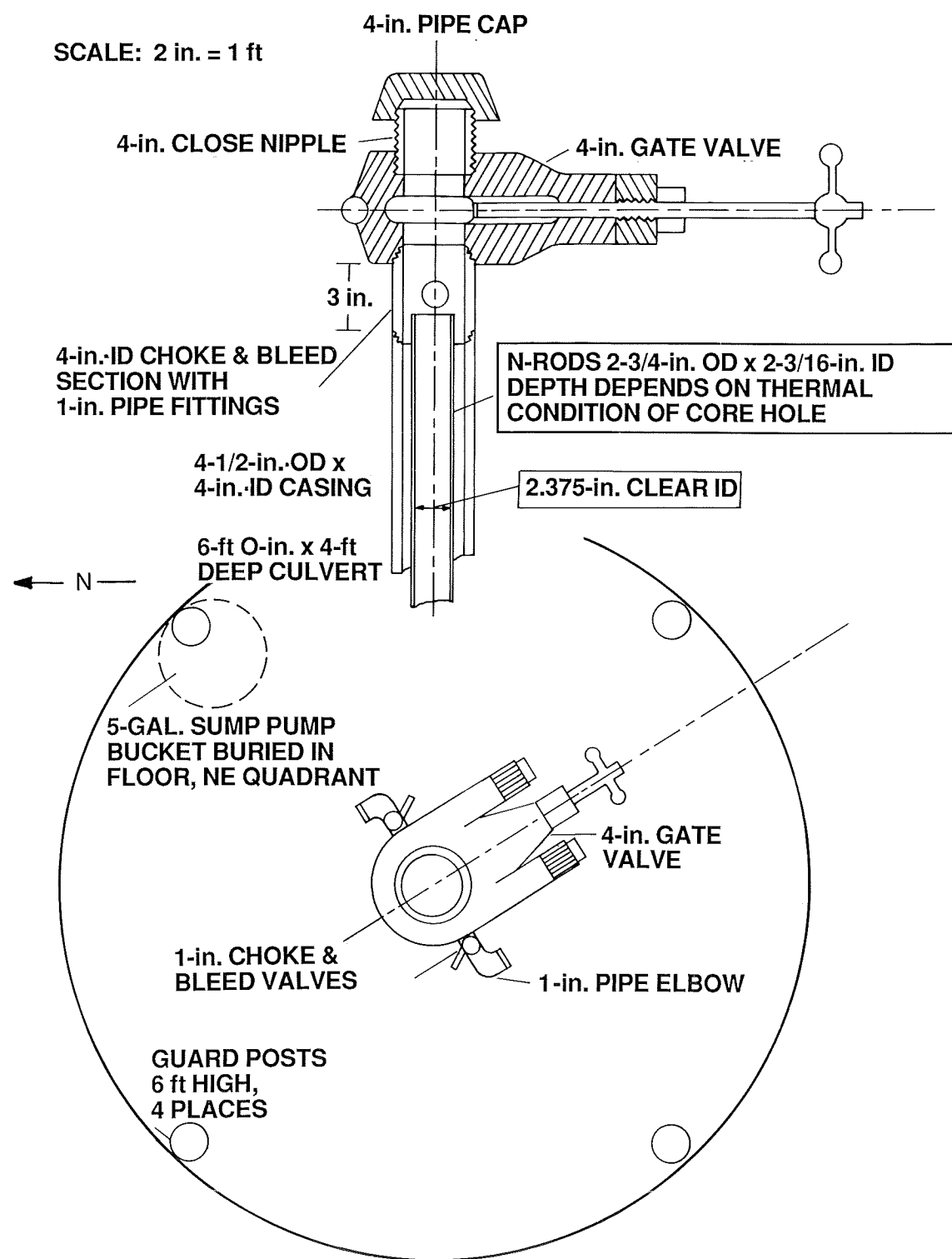

Fig. 14.
VC-1 top hole and wellhead configuration.

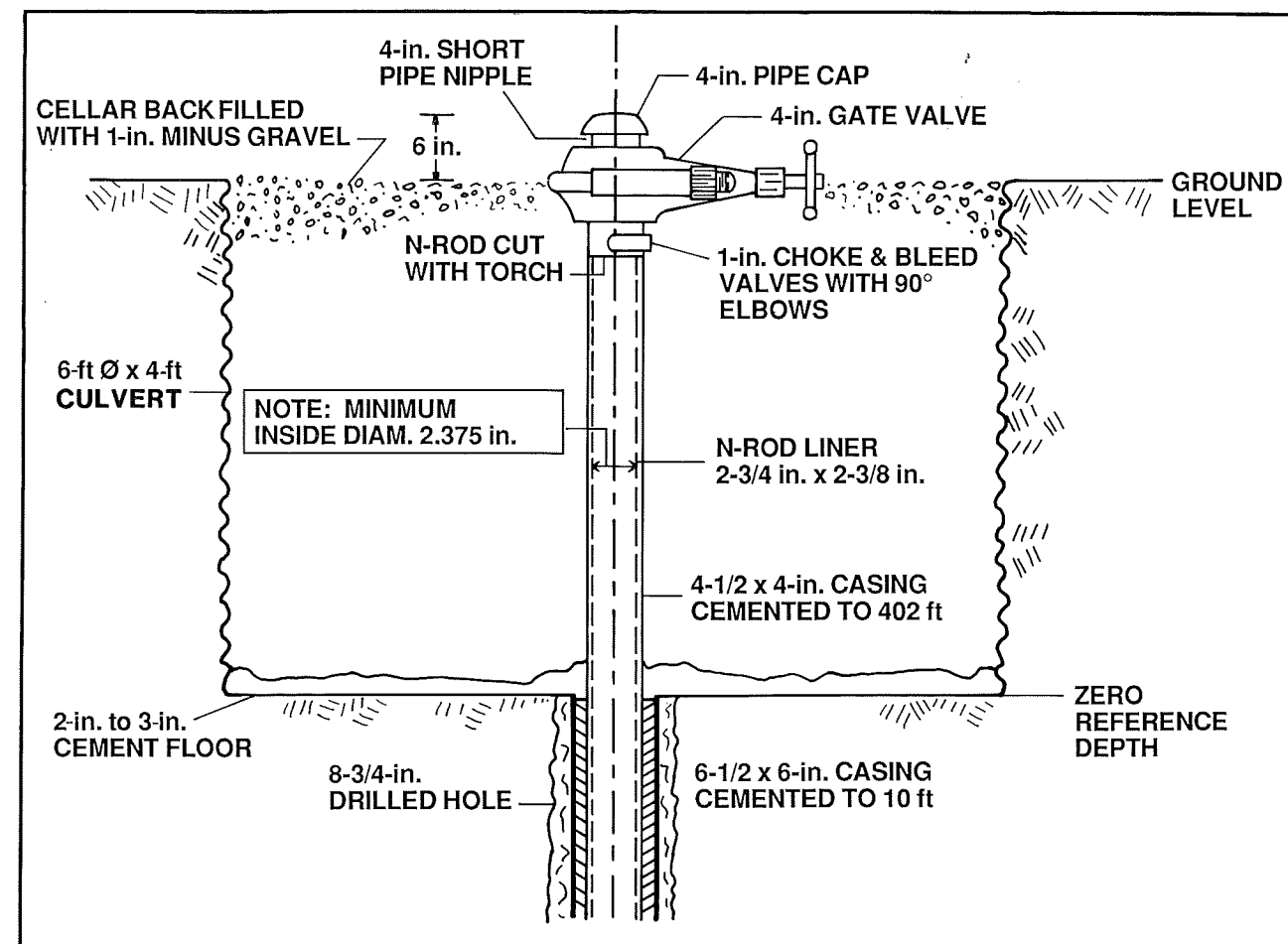

Fig. 15.
VC-1 cross section of cellar and gate valve installation.

was expected that the gray clay encountered at the current total depth of VC-1 is a very thin zone overlying the Precambrian granite. It is also likely that the Abo Formation from 332.8 to 421.8 m (1092 to 1384 ft) has squeezed in around the N-rods in that depth interval and sealed off the upper, cooler aquifers from the lower hydrothermal entries.

Figure 16 provides a summary of significant rig activities, partitioned by percentage of total rig operating time. As can be seen, actual coring occupied about 60% of the total time, an excellent record. Less than 4% was spent solving problems such as rig repairs, waiting on water, and fishing. The difficulty with coring some of the formations is illustrated in Fig. 16 by the hole conditioning time (3.7%). This activity was required to clean out silt and wall cave-ins and blockages and to treat the squeezing clay zones, primarily in the Abo Formation (Fig. 2). The low percentage of time spent on

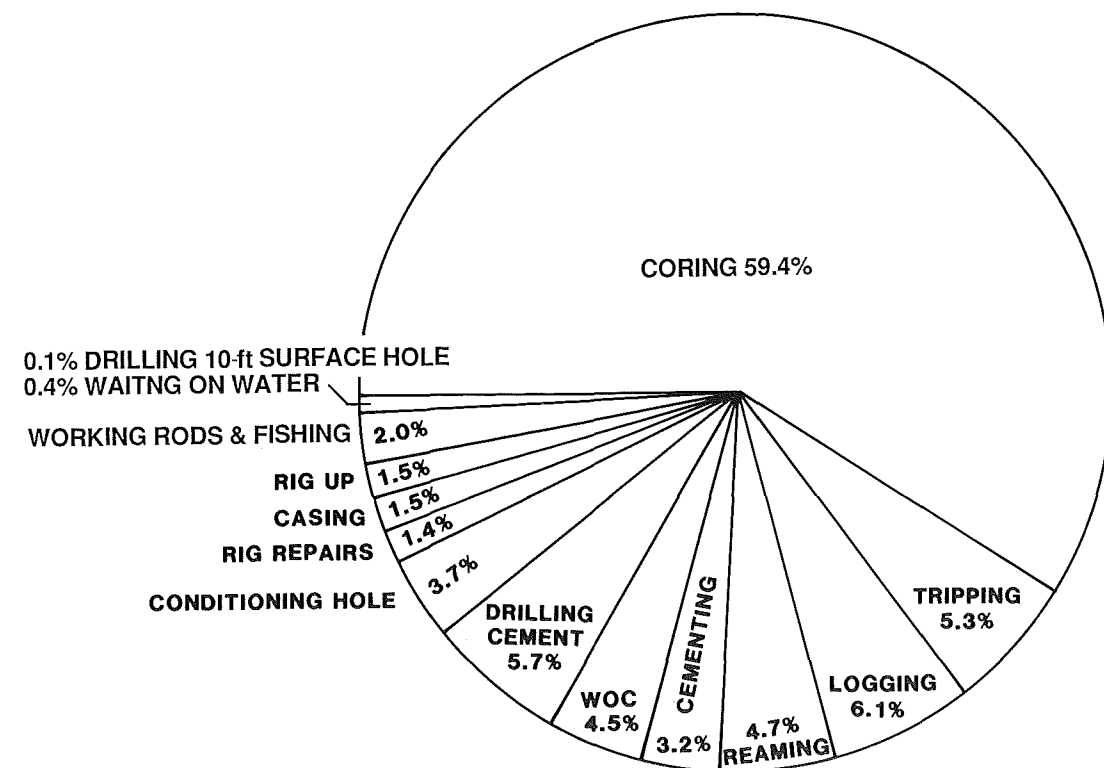

Fig. 16.

Activities by percentage of total rig time. (WOC means waiting on cement.)

problems is a reflection of the quality and condition of the rig equipment and the effectiveness and experience of the rig crew members. The remainder of the time, 26.4%, exclusive of logging (6.1%; see Section V below) was spent in direct support of the coring and borehole completion operations. The borehole is now ready for future hydrologic testing and for running logging tools or instruments and other planned experiments.

C. Core Recovery

Figure 17 records the core recovery data for each of the 367 core runs for VC-1. Average recovery exceeds 95%. The low initial recovery down to approximately 45 m (150 ft) is a direct result of the very fractured rock penetrated, which was a flow breccia of Banco Bonito rhyolite. Once reasonably competent Banco Bonito obsidian was reached, core quality and recovery attained high levels, and excellent recovery was maintained for the remainder of the coring as shown on Fig. 17. Cored intervals that resulted in less than 100% recovery are generally in badly fractured, poorly consolidated breccia or clay-rich formations (for example, Fig. 18). The amount and quality of the core recovered were consistently high throughout the entire operation (Fig. 17).

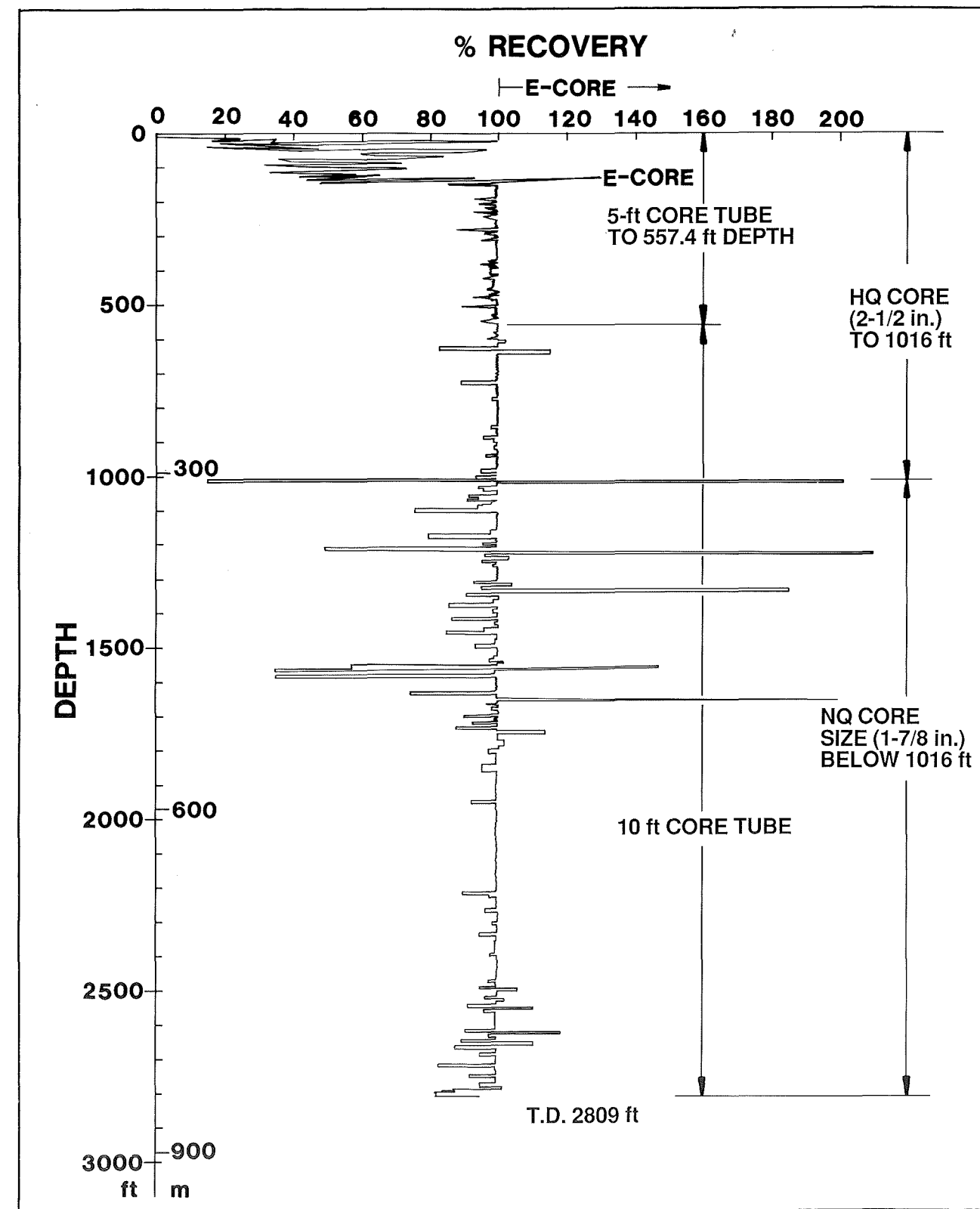

Fig. 17.

Record of VC-1 core recovery (see Appendix for explanation of E-Core).



Fig. 18. Soil, rubble, and obsidian from core runs 1 through 5, to a depth of approximately 21 ft. Note poor recovery in this zone.

Extra core* was occasionally recorded, for example, Fig. 17 at 45-m (150-ft), 300-m (1000-ft), and 488-m (1600-ft) depths. In most cases the extra core (denoted E-core) resulted from picking up core that had been lost from a previous core run. (The core probably slipped from the core catcher and out the end of core tube.)

Figure 18 shows a core box with core down to about 8.5 m (28 ft), where the rock is Banco Bonito rhyolite flow intercalated with soils. Figures 19 and 20 illustrate the typically high recovery achieved at two deeper intervals in VC-1. These two figures also illustrate the marking procedures that were carried out by the well-site geologic team. This 24-person team followed the CSDP core curation procedures established by the CSDP/Core Curation Manager for the DOE/OBES (S. Goff 1986). The VC-1 coring operation provided a field test of these prototype procedures. Figure 21 shows a VC-1 well-site geologist washing and marking core according to these procedures.

D. Core Bit Performance

Core bit performance for the drilling of VC-1 was excellent. Only five bits were used (Table IV). The HQ-size core bits had shorter bit life than did the NQ bit; four bits were used to reach a depth of 309.7 m (1016 ft). The rock in this interval, especially the Banco Bonito rhyolite, is difficult to core, which resulted in low rates of penetration (ROP) and rather rapid bit wear. However, only a single NQ bit was used from 309.7 m (1016 ft) to total depth. The bit type selected, an oversize Longyear Green, series 1, is generally considered suitable for medium-hard, abrasive rock.

Table V records average advance rate (AAR) and ROP data for the VC-1 coring operations. For evaluation and planning purposes the AAR data are applicable. Based on the total project duration of 33 days, the AAR was 25.9 m/day (85.1 ft/day). During actual drilling (24 days), the AAR was 36.7 m/day (117 ft/day). The bits used at various depths and in various sizes are recorded in Table IV. The relatively low variability in AAR, based on actual days spent drilling (Items 2, 3, 4, 5, and 7, Table V), shows consistency and uniformity in rig and crew performance. Table V also shows the instantaneous penetration rate and the ROP in m/h (ft/h) for the major stratigraphic units of VC-1. Generally decreasing ROP with depth is clearly evident. Also, distinct variations in ROP from unit to unit are evident. These drilling rate

*See Appendix for explanation of extra core or E-Core.

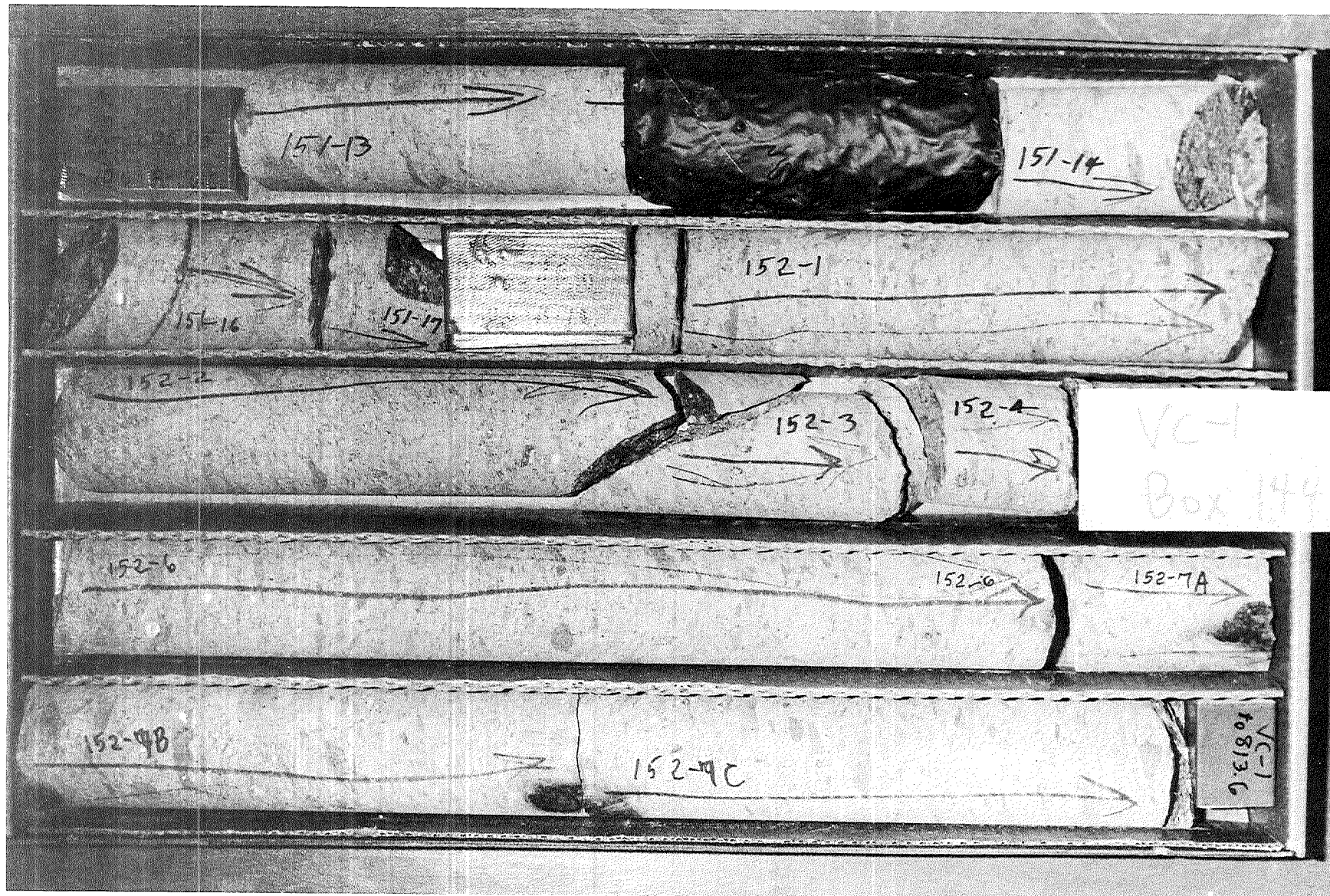

Fig. 19.
Core runs 151 and 152, depth 805 to 813.6 ft. Densely welded Lower Bandelier Tuff showing core markings. Note the waxed section. Note excellent recovery of intact core (see Fig. 17).



Fig. 20.
Core runs 332 and 333 from the Madera limestone. Note recovery in very fractured zone, depth interval 2494.5 to 2502.6 ft (Box 370).

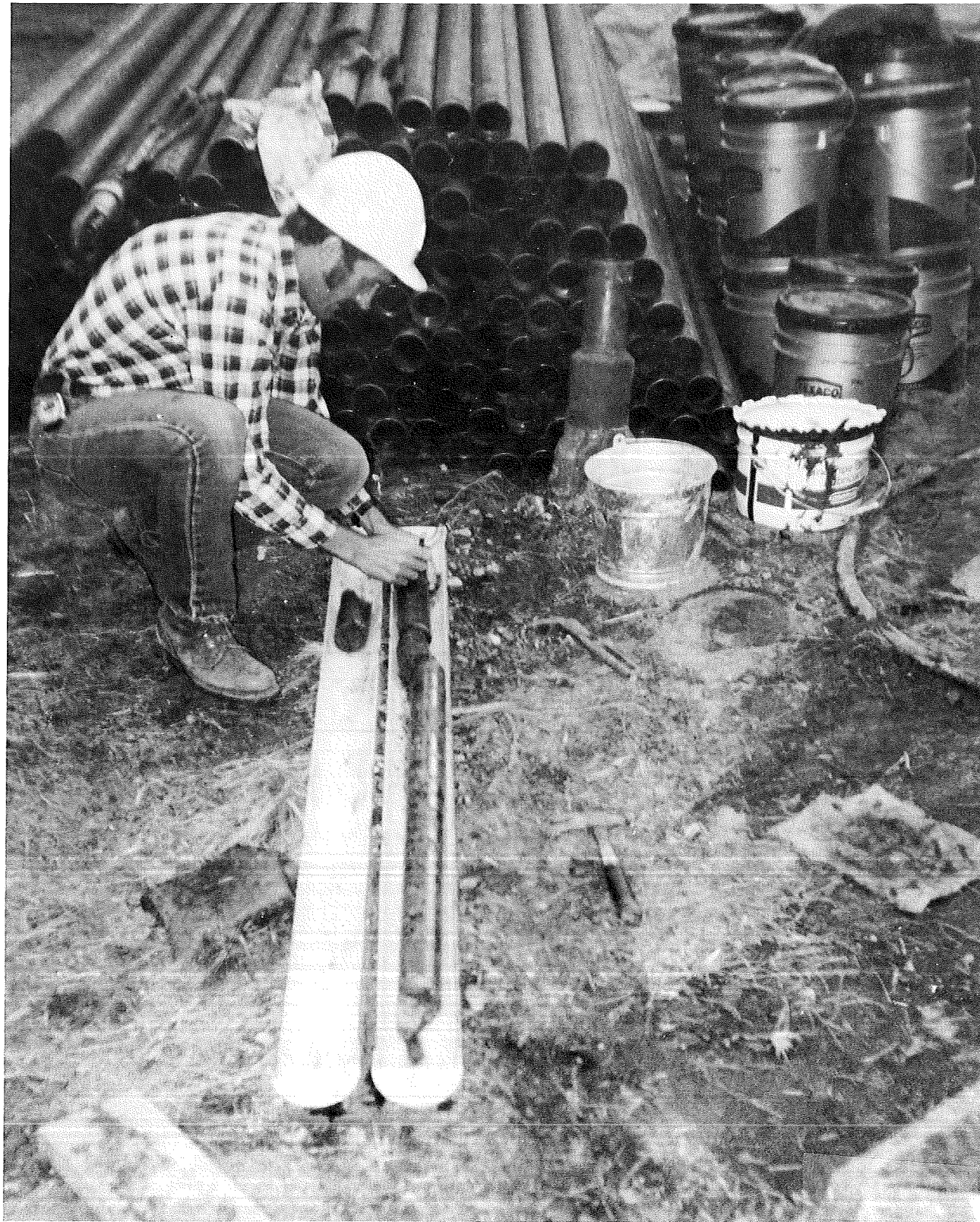

Fig. 21.

On-site geologist washing and marking core at the well site according to CSDP curation procedures (S. Goff 1986).

TABLE V
VC-1 CORE BIT PERFORMANCE SUMMARY

Item	Depth Interval		Time Days	AAR ^a		ROP		REMARKS
	m	(ft)		m/day	(ft/day)	Avg. $\left\{ \begin{matrix} \text{max} \\ \text{min} \end{matrix} \right\}$	Avg. $\left\{ \begin{matrix} \text{max} \\ \text{min} \end{matrix} \right\}$	
					m/h	(ft/h)		
A. AVERAGE PERFORMANCE								
1	0-856	(0-2809)	33	25.9	(85.1)	-	-	Total project, average advance rate, HQ & NQ bits.
2	0-856	(0-2809)	24 (75%)	35.7	(117.0)	-	-	Actual drilling days, total project, HQ & NQ bits.
3	0-122	(0-400)	3	40.6	(133)	-	-	Various intervals, see Fig. 1.
4	0-310	(0-1016)	7	44.7	(145.1)	-	-	Average advance rate HQ bit.
5	122-310	(400-1016)	4	46.9	(154)	-	-	(Switched from 1.5- to 3-m (10-ft) core barrel at 162 m (532 ft) depth.
6	310-856	(1016-2809)	19	28.7	(94.4)	-	-	Total days, average advance rate NQ bit.
7	310-856	(1016-2809)	17	32.1	(105.5)	-	-	Actual drilling days, average advance rate, NQ bit.
B. INSTANTANEOUS PERFORMANCE								
								MAJOR STRATIGRAPHIC UNITS
8	122-151	(400-495)	-	-	-	7.3 $\left\{ \begin{matrix} 12 \\ 3.7 \end{matrix} \right\}$	(24.0) $\left\{ \begin{matrix} 40 \\ 12 \end{matrix} \right\}$	Banco Bonito
9	151-168	(495-550)	-	-	-	6.0 $\left\{ \begin{matrix} 9.1 \\ 3.7 \end{matrix} \right\}$	(20.0) $\left\{ \begin{matrix} 30 \\ 12 \end{matrix} \right\}$	Battleship Rock Tuff
10	168-181	(550-595)	-	-	-	5.2 $\left\{ \begin{matrix} 7.3 \\ 3.3 \end{matrix} \right\}$	(17.1) $\left\{ \begin{matrix} 24 \\ 11 \end{matrix} \right\}$	Obsidian
11	181-198	(595-650)	-	-	-	5.1 $\left\{ \begin{matrix} 12.2 \\ 3.0 \end{matrix} \right\}$	(16.7) $\left\{ \begin{matrix} 40 \\ 10 \end{matrix} \right\}$	Upper Bandelier Tuff
12	198-332	(650-1090)	-	-	-	4.3 $\left\{ \begin{matrix} 12.2 \\ 1.5 \end{matrix} \right\}$	(14.0) $\left\{ \begin{matrix} 40 \\ 5 \end{matrix} \right\}$	Lower Bandelier Tuff
13	332-422	(1090-1385)	-	-	-	2.0 $\left\{ \begin{matrix} 6.1 \\ 1.2 \end{matrix} \right\}$	(6.7) $\left\{ \begin{matrix} 20 \\ 4 \end{matrix} \right\}$	Abo (Red Beds)
14	422-838	(1385-2650)	-	-	-	2.9 $\left\{ \begin{matrix} 6.1 \\ 1.5 \end{matrix} \right\}$	(9.5) $\left\{ \begin{matrix} 20 \\ 5 \end{matrix} \right\}$	Madera
15	838-853	(1250-2800)	-	-	-	3.3 $\left\{ \begin{matrix} 6.1 \\ 2.1 \end{matrix} \right\}$	(10.9) $\left\{ \begin{matrix} 20 \\ 7 \end{matrix} \right\}$	Sandia

^a Average of total depth cored over total time for the interval.

breaks are shown in Fig. 22. Penetration rates are strongly influenced by the coring characteristics of the rock. Filling the inner or core tube barrel (recovery) and obtaining high-quality core influenced drilling rates significantly. This was a primary objective, and the incentive to core rapidly was secondary. It was generally possible to fill a 3-m (10-ft) core tube in 1/2 to 1-1/2 h.

Figure 22 is a strip graph of the drilling time log for each 1.5 m (5 ft) drilled; the drilling time is plotted vs. depth interval. These data are derived from the 0.3-m (1-ft) time record kept by the drillers with all the

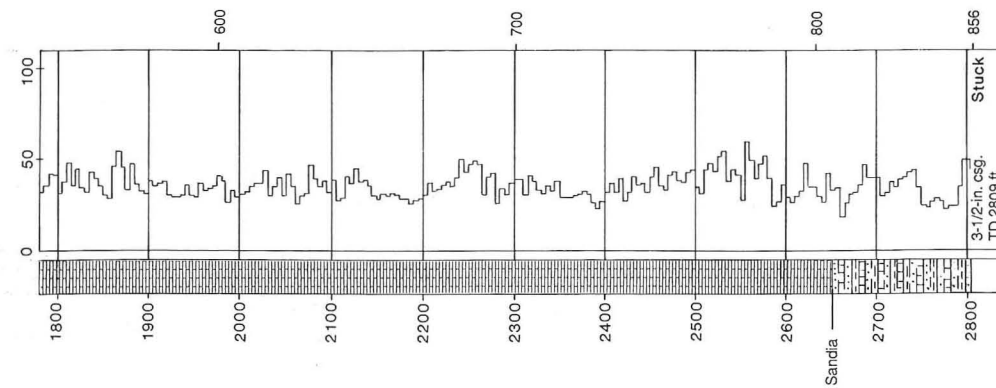
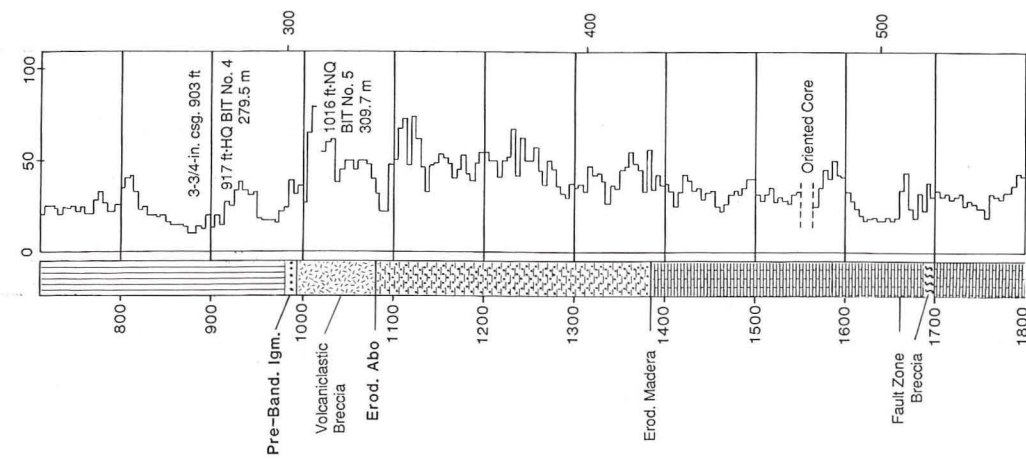
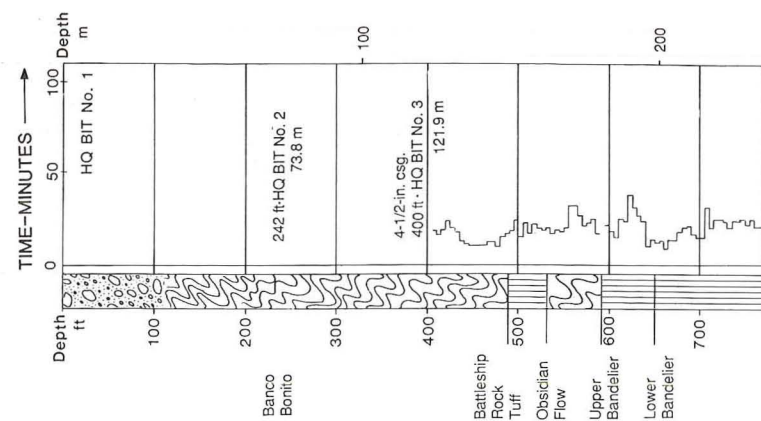

Fig. 22. Time to penetrate 1.5 m (5 ft) as a function of depth and stratigraphy in VC-1.

"down time" (nondrilling time) removed. When a roller-cone or fishtail bit is used for rotary drilling in sedimentary rock, the log usually mimics the neutron geophysical log curve and can often be correlated with drilling time logs of nearby holes. For the diamond core drilling of VC-1, the log definitely shows drilling rate changes (breaks) at the eroded top of the Abo, the Battleship Rock Tuff, the Lower Bandelier contact, and also the fault at 506 m (1660 ft). Other formation changes do not show up quite so well. Correlation with the reduced scale (1 in. = 100 ft) neutron log curve is good in some places and nonexistent in others (see Section VI below).

E. Drilling Fluid

The drilling fluids program for VC-1 was based on several factors.

- (1) The anticipated geological sequence as described in the drill rig specifications ("Specifications for Core Hole Drilling and Testing Operations at Southwest Caldera Rim Area" by Rowley and Goff) (Fig. 23): The formations, in descending order, were thought to be rhyolite flow, pumice and intracaldera tuff, Bandelier Tuff, andesite, red sandstone, limestone and Precambrian granite, and gneiss. Fractured volcanic rocks, water-sensitive formations, structurally unstable zones, loss of circulation, and temperatures in excess of 130°C (266°F) were anticipated. This hostile drilling environment led to the selection of a low-water-loss mud with a minimum circulating density to control loss of circulation and unstable formations. An inverted rheology mud was considered to be needed to help clean the hole of cuttings.
- (2) Experience with the anticipated formations from previous drilling: Los Alamos National Laboratory at Fenton Hill, Union Oil Company at the Baca locations, Sunedco at Cat Mesa, and a well near the city of Jemez Springs.
- (3) The major technical objectives: The objectives were to wireline core continuously from surface to total depth, maximize core recovery, and maintain an open hole for instrumentation and installation of casing or liner. These objectives indicated a low filtrate mud with an encapsulating polymer to aid in core recovery.
- (4) A hydraulic core rig with a Bean 50 pump to be used by Tonto Drilling Company: The steel rig tanks were a 280-gal. mixing tank with a mixing hopper. The pump was adequate for the coring operations,

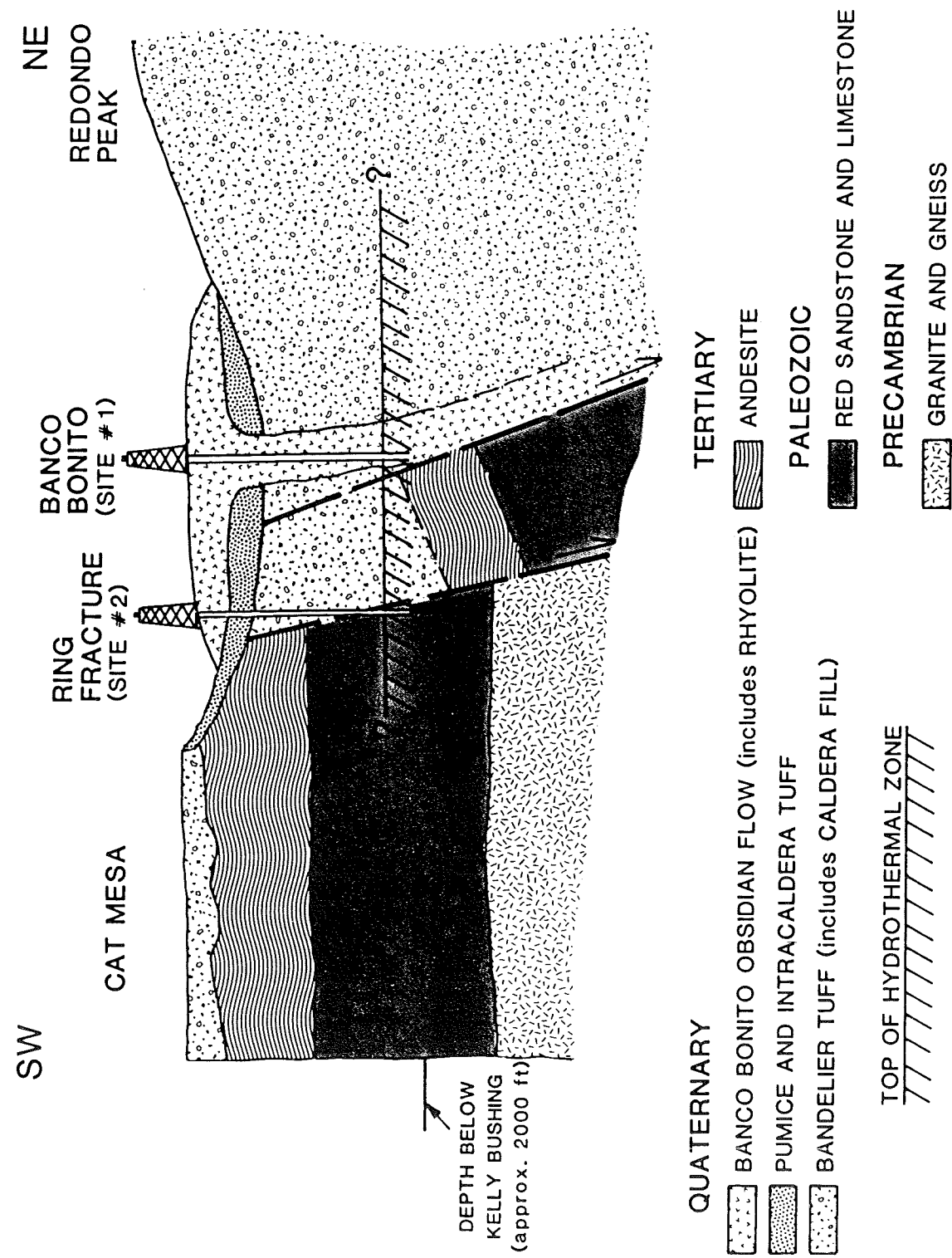

Fig. 23.
Geologic cross section used for planning VC-1 drilling fluid additives program.

but close watch on hydraulics was important. The mixing hopper was submerged in the tank.

- (5) The hole design (Fig. 6): It included a surface hole, rotary drilled with a 8-3/4-in. bit to 10 ft to accept 6-1/2 in., with casing to be set in cement. HQ size (3.83-in. O.D.) coring to 400 ft followed. The hole was reamed to 5-5/8 in., and 4-1/2-in. casing was set. HQ coring was resumed. The rotary drilling and reaming of the hole were done with a bentonite and polymer mud program without concern about filtrate. The cored portion of the hole definitely required a low filtrate and a very thin wall cake for the close annular space (about 0.2 in.) to prevent differential sticking and to obtain good core.
- (6) Environmental considerations and the US Forest Service permit: All products used had to be environmentally safe. For example, a potassium chloride drilling fluids system would be used only as a last resort to remedy extremely bad hole conditions.

1. Water Usage. The drilling plan for VC-1 assumed that complete loss of circulation would be experienced for the entire drilling project. The Tonto Drill No. 1 was equipped with integral rig fluid tanks and a hydraulically driven mud pump with a capacity of about 2.7 m³/h (12 gpm). Therefore, with continuous fluid loss, about 65.6 m³/day (17,300 gal./day) of water would be used. Water was hauled from La Cueva, Fig. 10 (about 3-1/2 road miles) by a 12.7-m³-capacity (80 bbl = 3360 gal.) tank truck. For logistical reasons, a 37.9-m³ (10,000-gal.) storage tank was located at the VC-1 site (Figs. 7 and 8). The tank truck filled the storage tank at dawn and in the evening with about three tanker-truck trips per fill.

It was especially important that an adequate water supply be available on site so that the borehole would not run dry. Dry hole conditions significantly increase the risk of borehole wall instability, caving, and sloughing into the annulus between the rods and borehole wall. In addition a dry hole increases the occurrence and severity of rod vibrations caused by friction, which must be countered by withdrawing (tripping) the rods and applying rod grease. Interrupting the coring operations for rod withdrawal increases the risk of hole caving, reduces core quality, and introduces unproductive time. It is therefore desirable to maintain a significant fluid level in the hole for lubrication and to provide a sufficient hydrostatic head. Water supply

decisions and the assumption that circulation would be lost completely were based on previous drilling and coring experience in the Valles Caldera area.

Actual total water usage was 986.6 m³ (261 x 10³ gal.) for the 24 days of active coring, which resulted in an average usage rate of 39.8 m³ (10,500 gal./day), about half that expected.

2. Drilling Fluid Additives. The drilling fluid additives program was designed by NL-Baroid, on the basis of anticipated hole conditions, to yield the properties recorded in Table VI-A. The quantities to be mixed in the coring rig mix tank are as shown in Table VI-B. The components of the formulation are recorded in Table VII. Figure 24 indicates the use of the drilling fluids additives in relation to VC-1 stratigraphy and depth.

Figure 25 records the quantities of the various additives used partitioned into five-day intervals. The quantity usage rate reflects the water usage and severity of lost circulation encountered. It also is a result of the efforts to stabilize formations, such as the Abo, to maintain a clean hole, and to sustain high core quality and good recovery rates. The drilling fluid additives program contributed significantly to achieving high core quality and recovery to meet the scientific objectives of the VC-1 project.

TABLE VI

BASIC MUD PROPERTIES DESIGN

A. BASIC MUD PROPERTY VALUE OR RANGE

Viscosity: 33 - 35 s/qt
 Weight: 8.4 lb/gal.
 pH: 8 - 9
 Filtrate: 30 cm³/30 min. Upper hole
 Less than 20 cm³/30 min. Coring lower sections
 Wall Cake: Film to 1/32 in. max.

B. BASIC MIX - QUANTITY ADDITIONS TO EACH 1.1 m³ (280 gal.) MIX TANK

Material	Quantity
Soda Ash	1 qt
Quik Gel	1/2 sack
EZ Mud	3/4 qt

TABLE VII

DRILLING FLUID ADDITIVES DESCRIPTION

Product Name	Description of Material	Function or Use	Quantity & Guidelines
Soda Ash	Sodium carbonate	Conditioning make-up water by removing calcium ions.	Additions 1/2 to 1 qt per 280 gal.
Quik Gel	Beneficiated sodium bentonite	For viscosity, filtrate reduction, loss of returns, high-quality solids for the polymer to react with, and ease of mixing.	Base mix of 1/4 to 1/2 sack per 280-gal. tank.
EZ Mud	Anionic polymer emulsion	For hole stability, lubricity, filtration control, and improved core recovery.	Added 1/2 to 3/4 qt per tank. Added only after mixing soda ash and Quik Gel.
Dextrid	Modified polysaccharide organic polymer	To reduce filtrate, improve penetration rates, reduce circulating densities, and avoid use of chemical thinners.	Use at 4-8 qt per tank.
Cellex	Sodium carboxymethylcellulose	Increase hole-cleaning capabilities, promote hole stability in water-sensitive formations, and rapidly reduce filtrate.	Use at 1-1/2 to 3 qt per 280-gal. mix.
Dick's Mud Seal	Finely ground paper	Control lost circulation.	Added either by mixing 1 to 4 qt in mix tank or by adding down rods mixed in 5 gal. of water or mud. Also added by hand-ful to gunk mix in 5-gal. batch.
Kwik Seal	Finely ground mixture of granules, flakes, and fibers.	Used same as Dick's Mud Seal above.	
Torq-Trim II	Water soluble, nonpolluting lubricant.	Lubrication of sticky hole.	Added 1/2 to 1 gal., or slug down rods 1/2 qt.
ConDet	A concentrated detergent	For reducing torque and stabilizing water-sensitive formations.	Added same as Torq-Trim II or in conjunction with Torq-Trim II.

TABLE VII (cont)

TRADEMARKS AND REGISTERED PRODUCTS KEY

The following products are Registered Trademarks of NL Industries:

- QUIK GEL - Bentonite
- DEXTRID - Modified organic polymer
- CELLEX - Sodium carboxymethylcellulose
- TORQ-TRIM (R)II - Water soluble, nonpolluting lubricant
- CONDET - Concentrated detergent
- EZ MUD - Anionic polymer emulsion

KWIK SEAL is a Registered Trademark of Kelco-Rotary, Inc.
(Finely ground mixture of fibers, flakes, and granules.)

DICK'S MUD SEAL is a Registered Trademark of Cedar Fiber Company
(a ground paper).

F. Blowout Preventer

The expected subsurface conditions of a hydrothermal out-flow zone from the Baca Geothermal field mandated the use of suitable blowout prevention and control systems. The Forest Service permit dictated that the Geothermal Resources Operational Orders (GROO) (USGS 1976) procedures and equipment be used. These regulations required installation of a bag-type blowout preventer for the Baca field because of the high temperatures (<180°C) anticipated and because the site was to be used for exploration core hole drilling. However, a high-pressure and temperature-rated BOP stack was selected for VC-1 because it was very likely to intersect with the hydrothermal outflow from the Baca field, high temperatures (<180°C) were once again anticipated, and the site was possibly down the hydrologic gradient from the Baca field. The BOP equipment is designed for petroleum exploration; it is considerably stronger and has a higher pressure rating than that usually used for geothermal exploration. The equipment was furnished by Oil Field Rentals (Bakersfield, California), and the specifications are recorded in Table VIII. This unit consisted of the BOP stack, Fig. 26, and the separate control module, Fig. 7. The BOP stack was installed on the wellhead after the setting and cementing of the 4-1/2-in. casing to 402 ft depth. A secure cement job was accomplished with complete cement returns to the surface. The BOP controls were located adjacent to the site operations trailer about 5 m (15 ft) from the core rig

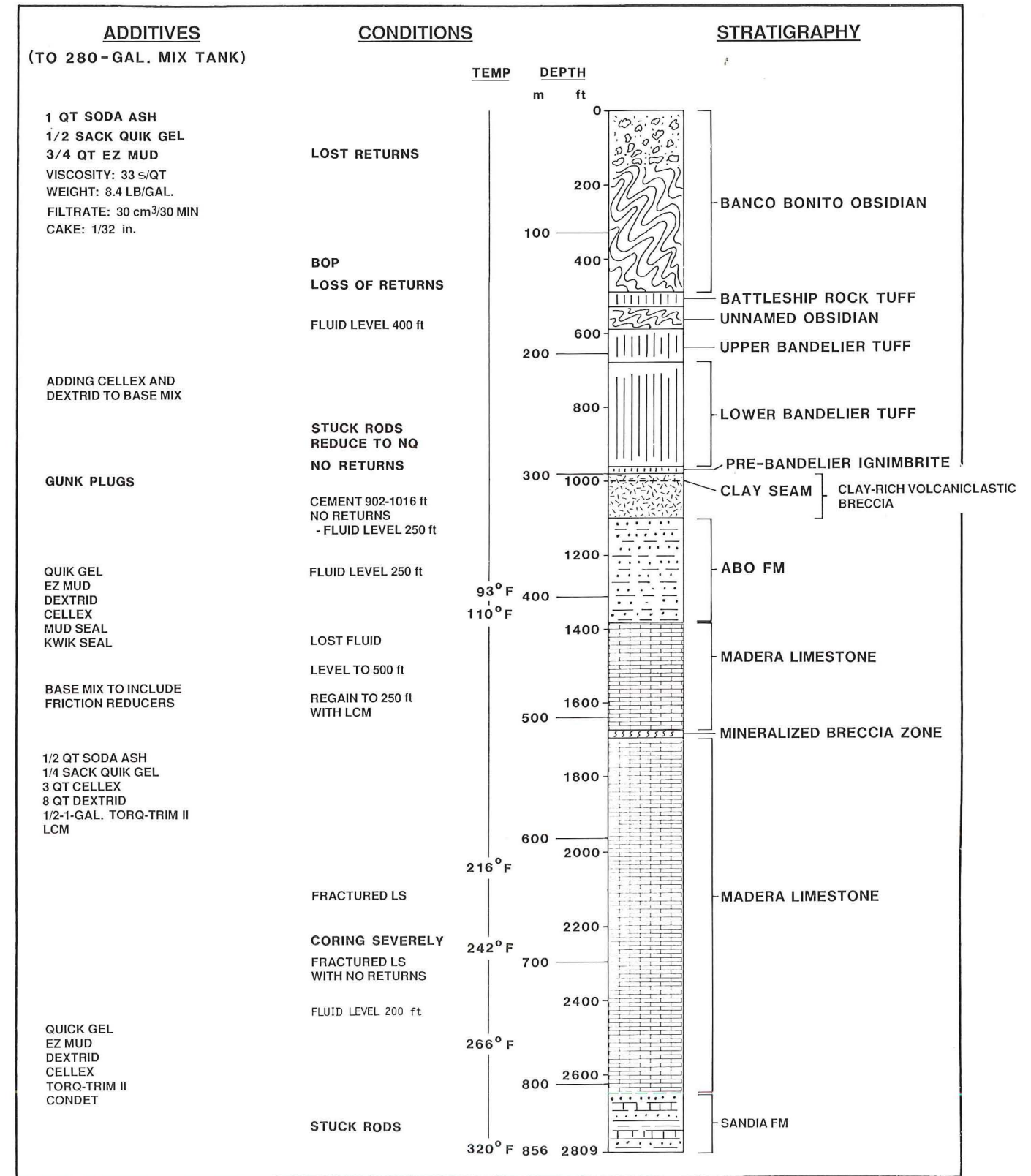

Fig. 24. Drilling fluid program and conditions for VC-1 coring and relation to stratigraphy.

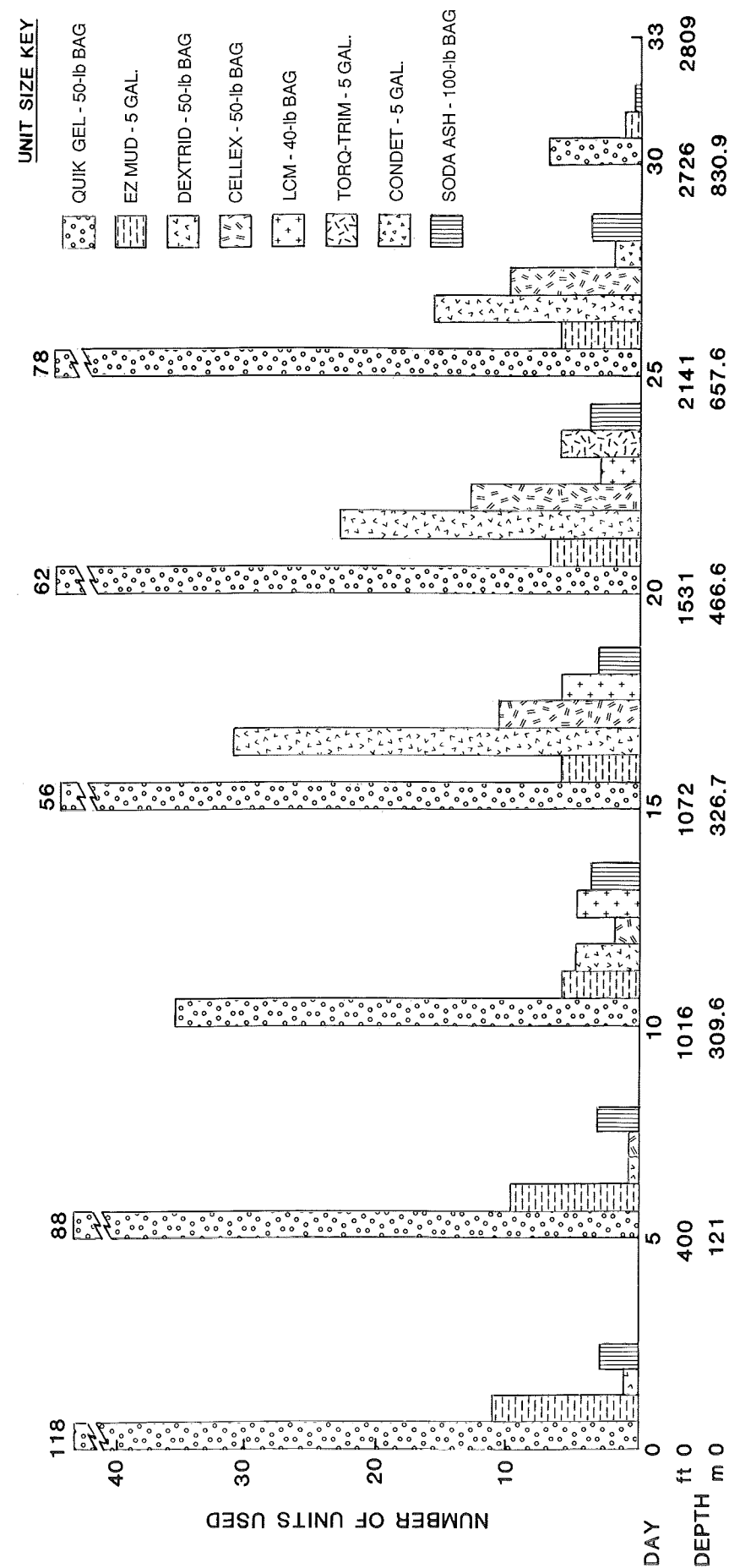

Fig. 25. Quantities of drilling fluid additives used in five-day increments.

TABLE VIII

VC-1 BLOWOUT-PREVENTER EQUIPMENT

1. Blowout preventer
Model: 900 Duke wellsite, 6-in. series with 3-1/2-in. pipe and blind rams (manufactured by Wellsite Specialists, Inc.); working pressure 3,000 psi.
2. Closing unit and accumulator
Three-station controls, 80 gal., Koomey with gasoline motor.
3. Hydraulic system
Maximum operating pressure to open--1,500 psi, to close--1,500 psi; ratio to close--4.2:1; volume of fluid to open--0.59 (US gal.), to close--0.72 (US gal.); piston stroke to open--4.125 in., to close--4.125 in.
4. Dimensions and weights
Weight: single--1,300 lb, double 2,300 lb; overall height, less studs, single--13-1/8 in., double--22-3/16 in.; overall length 63 in.; overall width, less handwheel, 21-1/4 in.; opening through preventer 7-1/16 in.; working pressure 3,000 psi; test pressure 6,000 psi; handwheel diameter 14 in.; ring joint gasket API number R-45.

(Fig. 8). This location optimized access to the controls by the rig crew and the on-site geologists if a rapid shut-in were required. The BOP system was exercised periodically, and when the rods were tripped out of the hole, the blind rams were closed as a precaution. No overpressure or flow conditions were experienced, and the BOP was not needed for blowout control, even though the core hole encountered several hydrothermal fluid entries and bottom-hole temperatures exceeded 160°C (355°F).

V. GEOPHYSICAL LOGGING

A suite of logs that included the gamma ray, caliper, density, single-point resistivity (resistance), self-potential (SP), temperature, and thermal neutron was to be obtained from the VC-1 core hole. Obtaining this information required at least two logging sessions. The first logging run was attempted on August 6, 1984, just before casing the first 122 m (400 ft) of the 14.29-cm-diam (5-5/8-in.) core hole. Only the gamma-ray, caliper, and

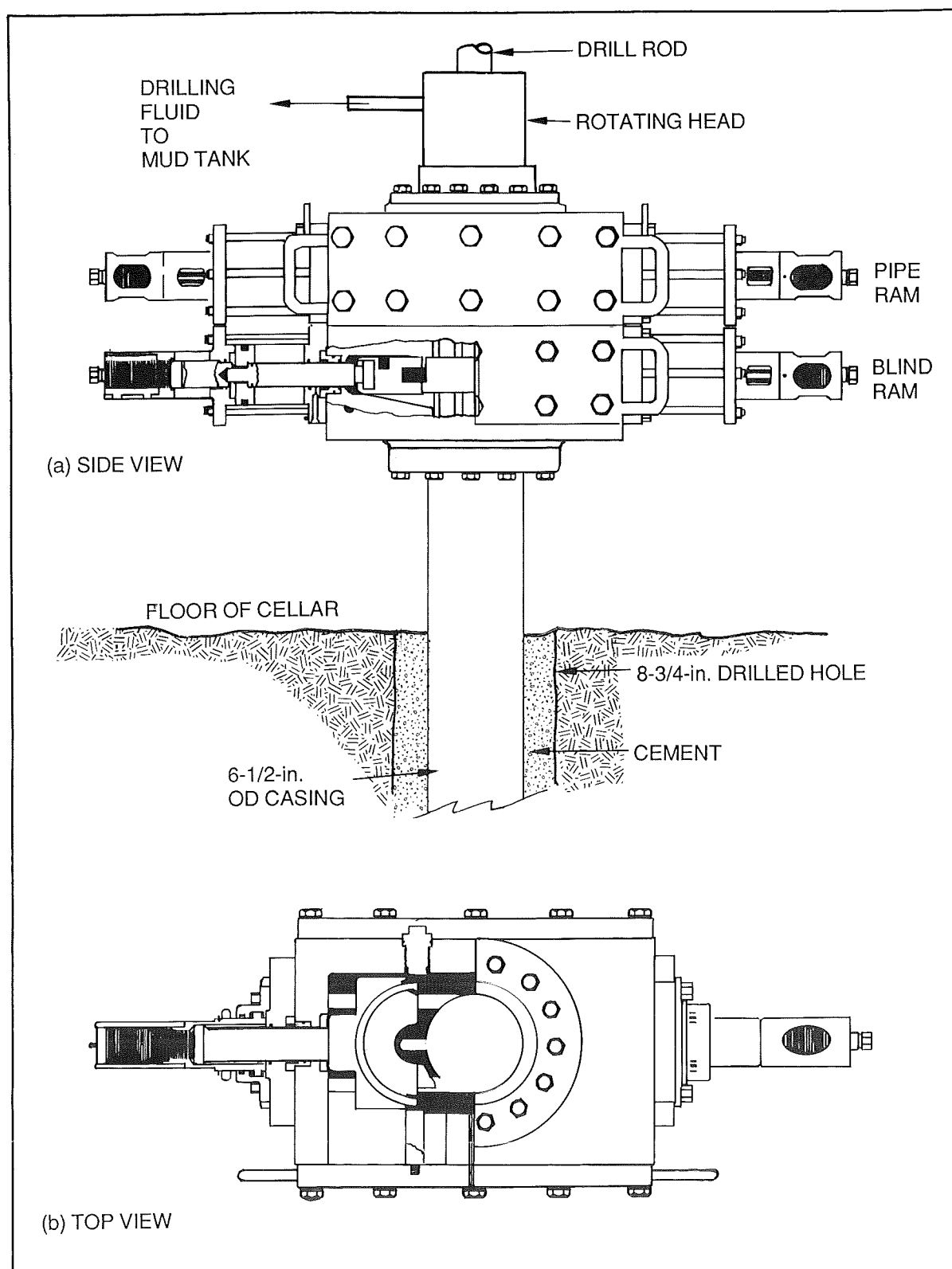

Fig. 26.
Blowout preventer assembly, blind, and pipe rams.

density logs were obtained from the surface to a depth of 36.5 m (120 ft) because of a bridge at the 36.5-m depth. No other logs were run at this time because of the bridge and the generally poor hole condition. The qualitative value of these logs ranges from good to excellent, but the quantitative value is unknown because of the lack of calibration before and after logging and the lack of a repeat run. Severe hole blockage (several bridges and a partial hole collapse) caused the hole to be cased with the stuck N-rods from the surface to 275 m (902 ft) depth.

After coring to a total depth of 856 m (2809 ft), logging of the deeper section was attempted on September 1 and 2, 1984, in the 77-mm-diam (3.03-in.) hole. The first log data were acquired following 12 h of hole cleaning and insertion of the drill rods. Because of unstable hole conditions, logging had to be done through the pipe or below the suspended pipe in intervals. The temperature, natural gamma, and neutron logs were run inside the rods. The temperature tool was run from 15 to 842 m (50 to 62 ft) where the sonde was stopped due to high temperature. Temperature data were obtained while going down hole (all other log data were obtained as the logging tool was drawn out of the hole). The qualitative value of this temperature log is excellent, although the quantitative value is unknown because no calibrations were recorded either before or after logging.

The logs acquired in intervals below the suspended pipe were the SP, caliper, density, and resistance. The SP, caliper, and resistance logs were obtained from a depth interval of 853.4 m (2800 ft) to 341.4 m (1120 ft) with a gap in the data from 358.4 m (1176 ft) to 427.3 m (1420 ft), where no logs were recorded because of the possibility of tool sticking. The density log was not run below 701 m (2300 ft) because of the temperature limitation of the logging tool. The qualitative value of the SP and resistance logs below 701 m is suspect because these tools were affected by the high temperature of the borehole. The caliper data from 341.4 to 853.4 m and the resistance, SP, and density data all from 341.4 to 701 m have good qualitative value. Again the quantitative value of all of these logs is unknown because no before or after log calibrations were performed and no repeat sections were recorded. These calibrations and repeat runs are essential for quantitative value because of the high temperatures and equipment failures encountered during the logging.

The third set of logs acquired was the gamma-ray and thermal neutron logs from a depth interval of 838.2 m (2750 ft) to the surface. These logs

were not obtained from the hole TD of 856.2 to 838.2 m (2809 to 2750 ft) because of the high borehole temperature. The qualitative value of these logs is excellent, but again the quantitative value is unknown due to lack of calibrations before and after logging and absence of repeat runs.

The geophysical logging coverage is summarized in Table IX and in Fig. 27. The geophysical logs are qualitatively compared with the stratigraphy derived from the core of VC-1 in Figs. 28 and 29.

Copies of all the analog and digitized records of the logs from VC-1 can be obtained from Rocky Mountain Well Log Services, Denver, Colorado, telephone (303) 740-7100.

VI. COST SUMMARY (1984\$)

The total cost (in 1984 dollars) for the VC-1 core hole was \$237,426.00.* This cost includes site preparation, core drilling contract, and related services and materials (Table X). These costs do not include transportation, technical staff, on-site geologists, supporting activities (e.g., environmental statement, safety and health inspections, archaeological survey, procurement, etc.), or the scientific and core curation activities conducted during or after the coring of VC-1.

The items in Table X are the usual subdivisions that reflect the major activities and items in the coring project. Item No. 5, third party, reflects the costs charged by the rig contractor to provide materials and service from other companies. The rate charged for third party was 10% of the invoiced amounts. The cost per unit depth is \$278/m (\$84.7/ft) for the VC-1 core hole drilling project.

*When the appropriate New Mexico State tax was added to this amount, the total outlay was \$247,268.00.

TABLE IX

SUMMARY OF VC-1 GEOPHYSICAL LOGS

Logging Session	Tools Logging Run	Depth Interval		Remarks
		m	(ft)	
First: 0 to 244 m (0 to 800 ft) Open hole section	Caliper	0 to 37	(0 to 120)	Hole caving and blockage.
	Compensated density	0 to 37	(0 to 120)	
Second: 244 to 775 m (902 to 2809 ft) Open hole section	Caliper	427 to 853	(1400 to 2800)	Tight hole in Abo and blockage in deeper zones.
	Temperature	0 to 847	(0 to 2780)	
	Total gamma	0 to 838	(0 to 2750)	
	Neutron	0 to 838	(0 to 2750)	
	Compensated density	427 to 853	(1400 to 2800)	
	Resistivity	427 to 853	(1400 to 2800)	
	SP	427 to 853	(1400 to 2800)	

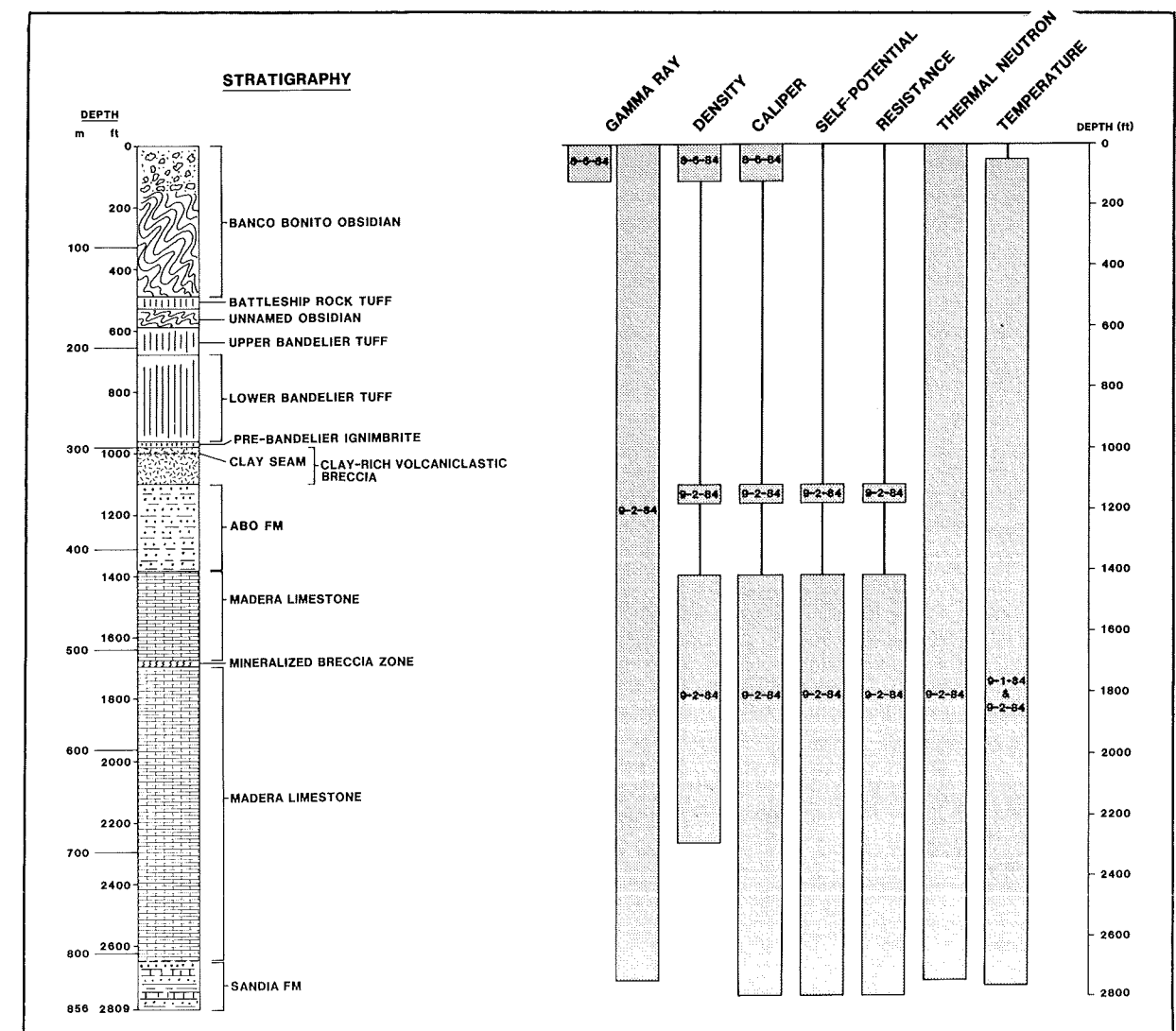

Fig. 27. Geophysical logging intervals in VC-1, in relationship to stratigraphy. Stippled bars with dates indicate logged intervals.

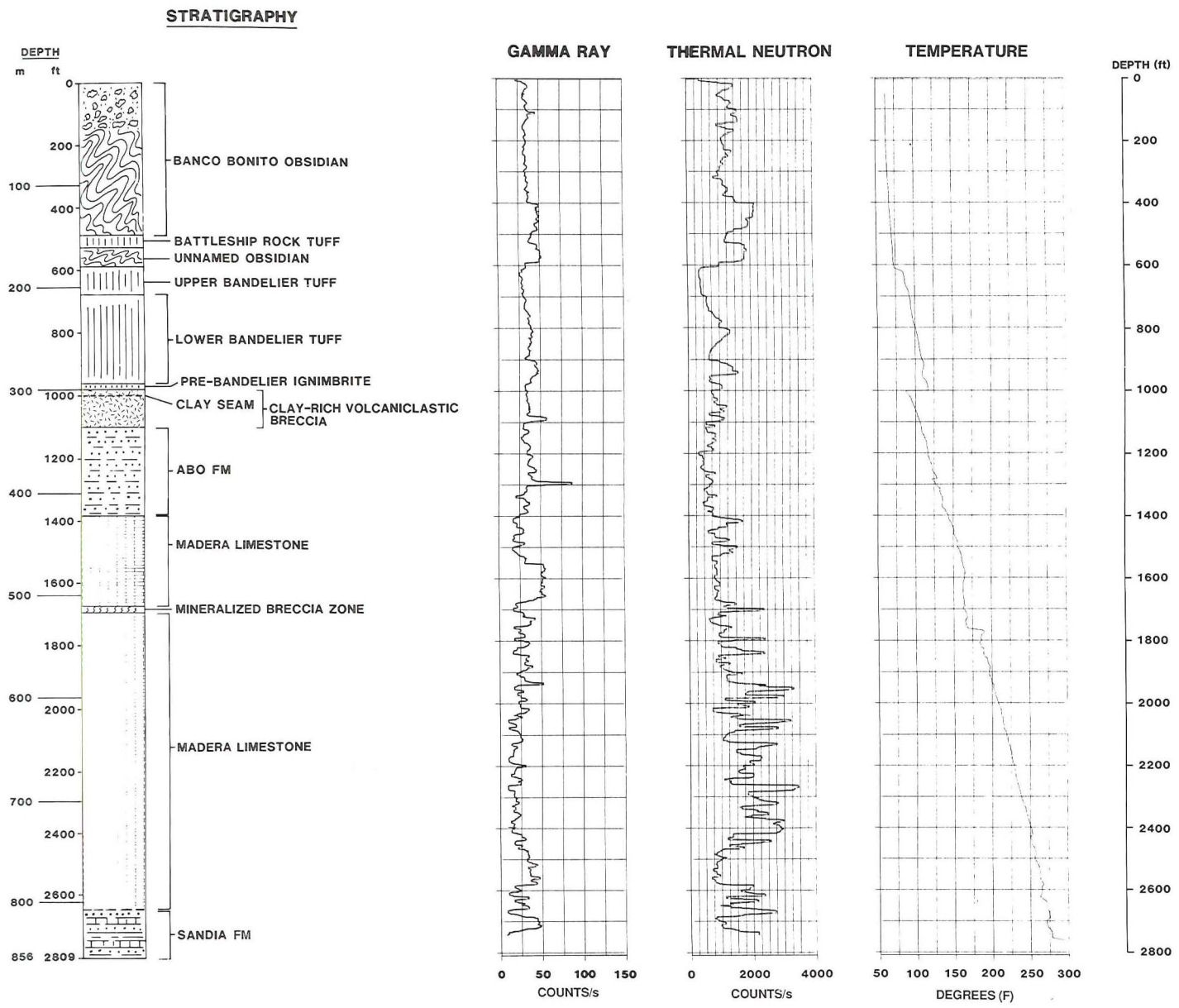

Fig. 28.
Geophysical logs compared with stratigraphy from VC-1.

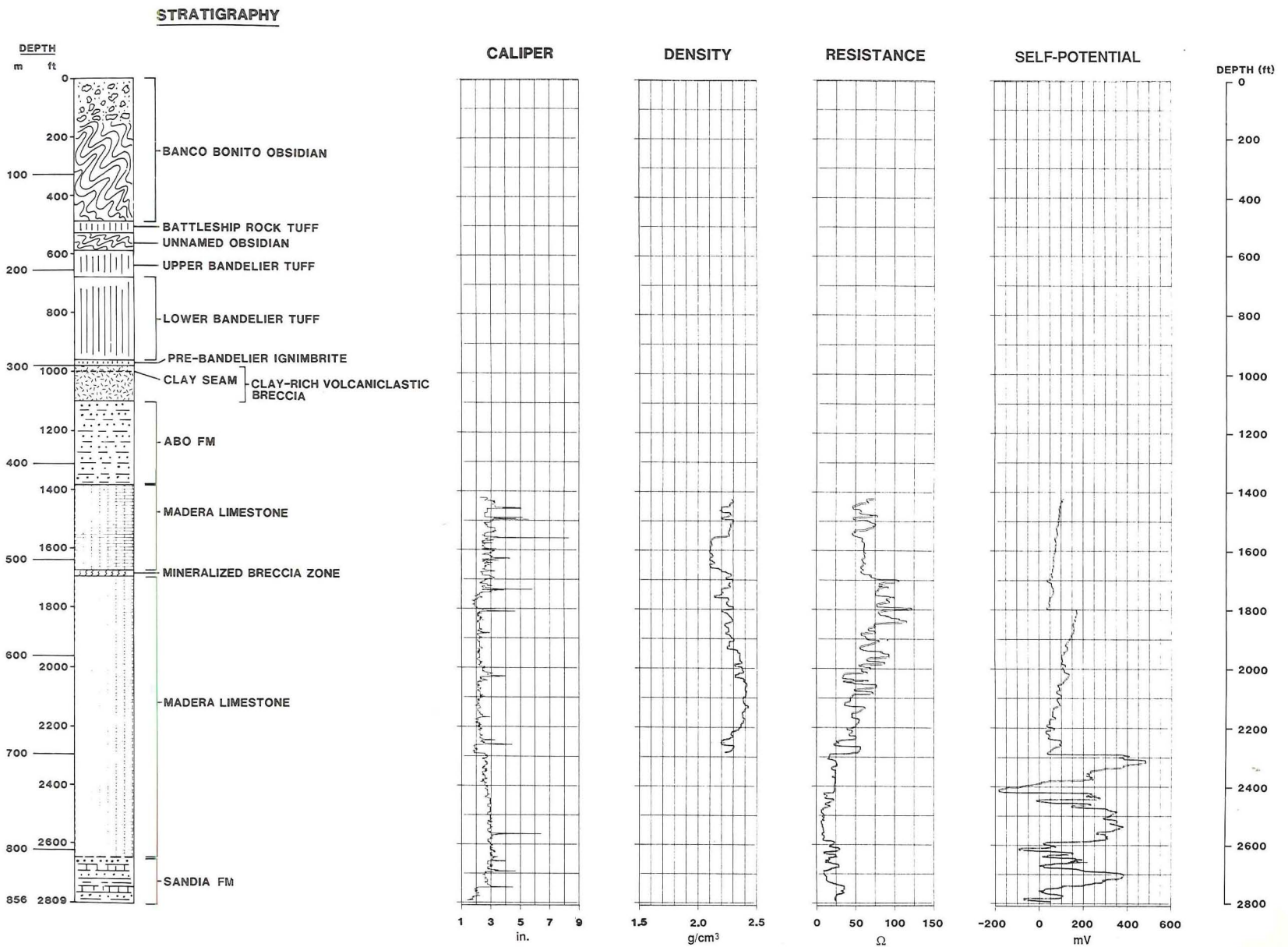

Fig. 29.
Geophysical logs compared with stratigraphy from VC-1.

TABLE X
VC-1 CORING COST SUMMARY

Items/Activities	\$ (1984)	Percent (%)
1. Access road and location preparation (road grading and cellar)	2,518	1.1
2. Logistical support (operations trailer and chemical toilet)	560	0.2
3. Rig mobilization and demobilization	8,700	3.7
4. Core rig (includes hourly rate, rotating-head rental, and crew per diem)	106,325	44.7
5. Third party	5,793	2.4
6. Core bits and three-cone bits	9,171	3.9
7. Water supply (water, trucking, and tank rental)	10,517	4.4
8. Fuel supply (diesel, gasoline, and tank)	4,167	1.7
9. Drilling fluid additives (materials and transportation)	21,059	8.9
10. Casing, tubing, rods, cement, and wellhead equipment	41,461	17.5
11. BOP rental, transportation, and handling	6,836	2.9
12. Geophysical logging	12,130	5.1
13. Oriented cores (rental, bit, and technician day rate)	5,539	2.3
14. Miscellaneous (e.g., rod grease, core boxes)	2,650	1.1
Total	\$237,426	99.9%
New Mexico State Tax	9,842	
GRAND TOTAL	\$247,268	

ACKNOWLEDGMENTS

This report is dedicated to the memory of James P. (Pat) Dunigan, former owner of Baca Land and Cattle Co., who fully appreciated the natural beauty and scientific value of Valles Caldera.

Many individuals contributed to the success of coring operations for VC-1 and became believers in the value of Valles Caldera to the CSDP and the earth sciences. The able crew of Tonto Drilling Services, Inc., drill rig No. 1, delivered first-class support for the coring operation. NL-Baroid, Inc., gave superb advice and material services on proper drilling muds. Many thanks to the multitude of well-site geologists, who volunteered their efforts night and day, seven days a week. Special thanks to Larry Maassen and Dan Miles (Los Alamos), who handled safety equipment and special drilling procedures for the project. Coleen Olinger (Los Alamos) took care of many of our environmental and cultural resource clearances. Cathy Stephenson, US Forest Service, Jemez Springs, New Mexico, was delightfully helpful with all our permitting procedures. Homer Pickens of Albuquerque acted as liaison between the Forest Service, Baca Land and Cattle Co., and Los Alamos. Thanks to Richard Dondanville of Union Oil Co., who helped design VC-1 during its very earliest stages. Program Manager for Geosciences, Office of Basic Energy Sciences, US DOE, is George A. KoIstad.

Appreciation is extended to the many individuals and companies that contributed their ideas and expertise and that provided special equipment and services in a timely and efficient manner.

APPENDIX

WIRELINE CORE BARREL OPERATIONS AND E-CORE DEFINITION

I. BASIC CORING OPERATION

The coring technology used for the VC-1 sampling program was directly adapted from minerals industry equipment. The narrow-kerf cone bit, Fig. A-1, is ideally suited for this type of top-to-bottom coring program. The surface equipment, drill rig, rotary drive, and controls are designed to optimize the high-quality and high-percentage recovery of core. This optimization is primarily a result of the low power and low bit loads needed by the narrow-kerf diamond core bits. Figure A-2 illustrates these factors and the basic equipment configuration. The core barrel assembly shown (much simplified) consists of the outer tube (or core barrel) that rotates via the drill rods (drill string) and the inner, nonrotating core tube (inner barrel) that does not rotate but into which the core is extended as the kerf is cut downward.

The inner core tube is retrieved with a wireline (cable) (Fig. A-3). The core is held in the inner tube by a core catcher located at the entrance (lower end) of the inner tube. The wireline has a latch (or overshot) on the bottom that engages a "pullhead" or fishing neck. Pulling breaks off the column of rock and retrieves the inner tube and core to the surface. Another core tube is immediately dropped (or lowered if the core hole is not water filled) down into the core barrel (outer core tube) and latched into place.

II. EXPLANATION OF EXTRA CORE (E-CORE)

Occasionally a bottom section of the core will fall out, or remain attached to the hole bottom when the inner core tube is retrieved with the wireline (Fig. A-3). This can result in the next core run having a piece of the previous core run on the top of the subsequent core run, as shown in Fig. A-4. The recognition of this E-Core situation is important to the proper curation and marking of the core, as explained by S. Goff (1986).

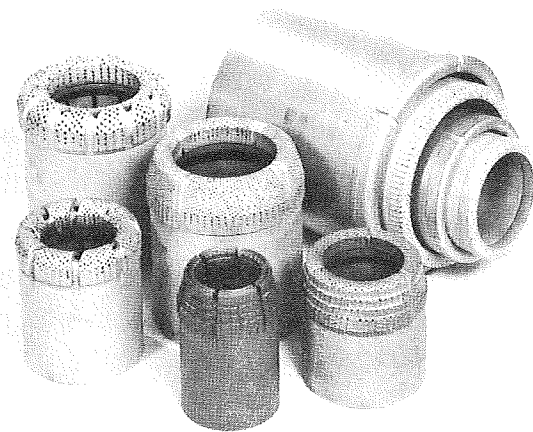
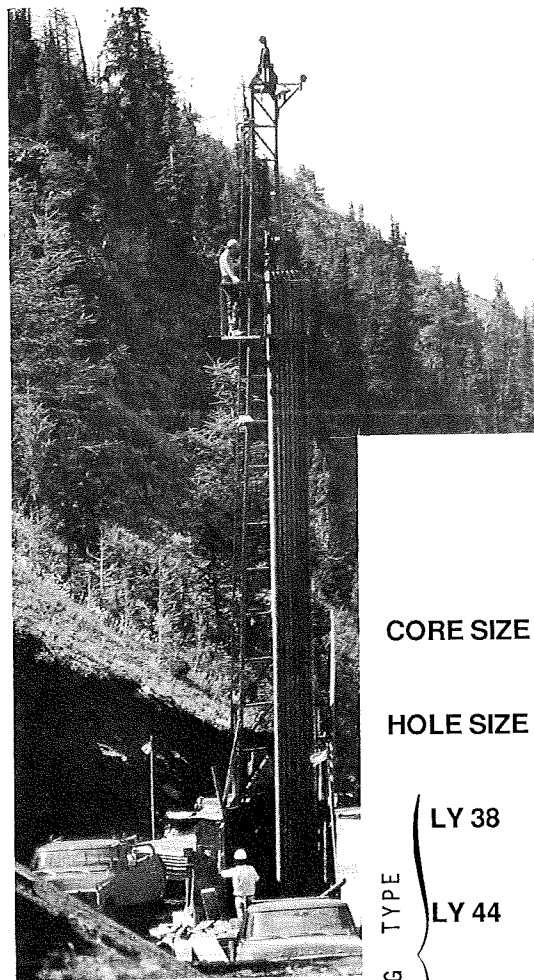

TYPICAL DIAMOND CORING RIG
DEPTH CAPACITIES vs. CORE SIZE

CORE SIZE	mm (in.)	B	N	H	P	
		36.5 (1.432)	47.6 (1.875)	63.5 (2.500)	85.0 (3.305)	
HOLE SIZE	mm (in.)	59.9 (2.360)	75.2 (2.980)	96.1 (3.787)	123.7 (4.872)	
RIG TYPE	LY 38	m (ft)	610 (2000)	548 (1800)	244 (800)	120 (400)
	LY 44	m (ft)	1070 (3500)	915 (3000)	760 (2560)	365 (1200)
	BB-56	m (ft)	1372 (4500)	1220 (4000)	853 (2800)	426 (1400)
	CP-50	m (ft)	2286 (7500)	1981 (6600)	1372 (4500)	762 (2500)

Fig. A-1.
Core bits.

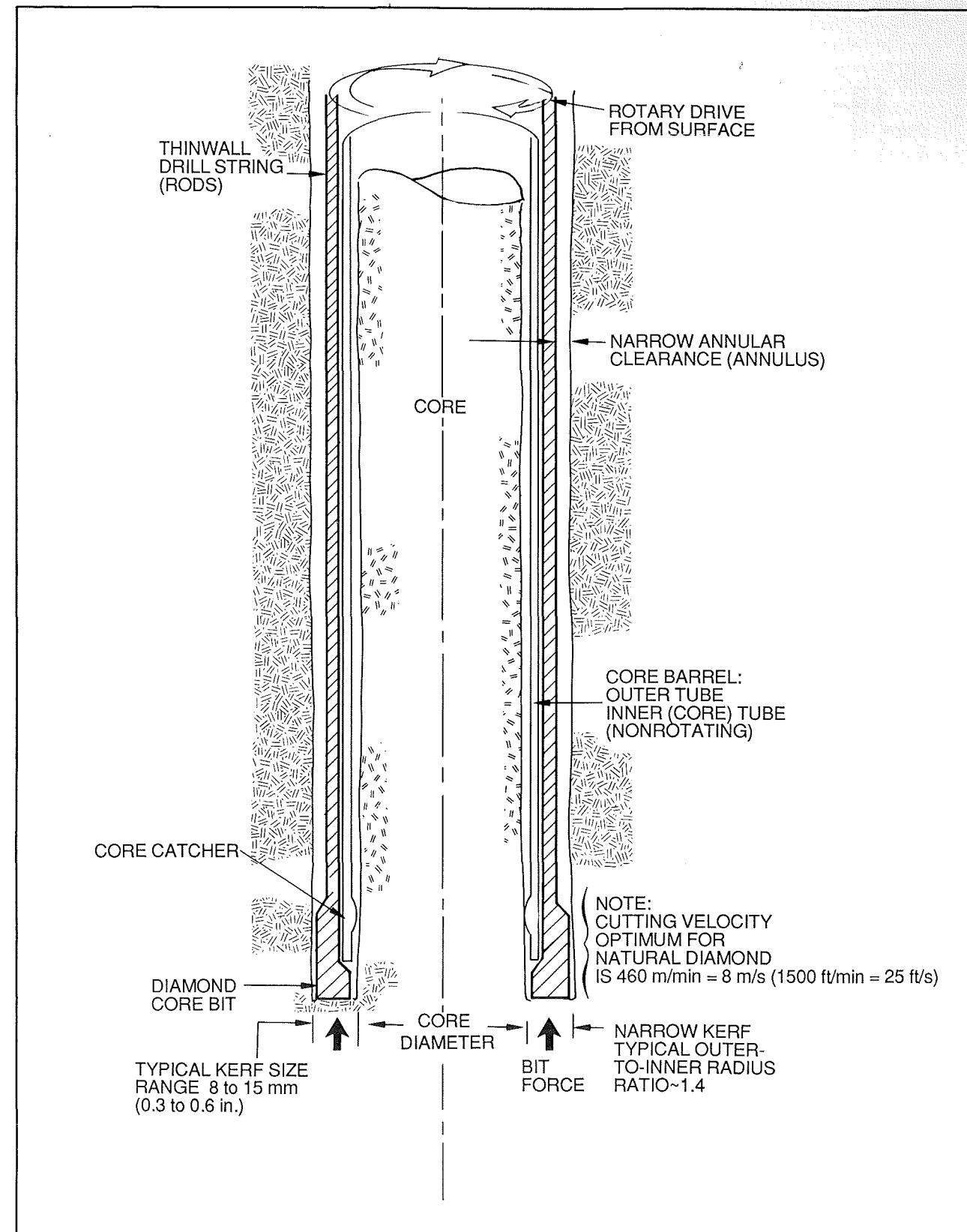

Fig. A-2.
Typical core drilling bottom-hole assembly.

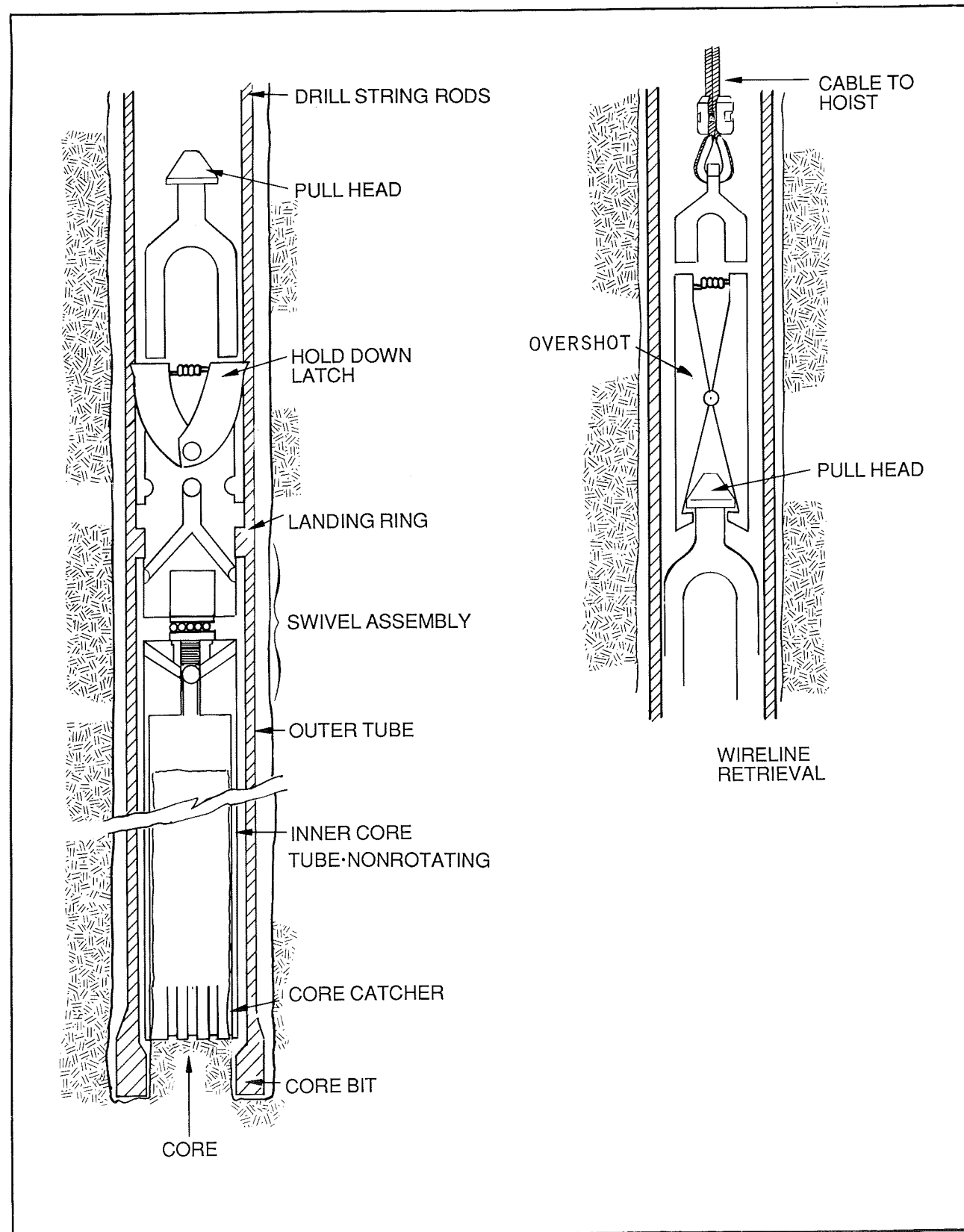

Fig. A-3.
Inner core tube retrieval system.

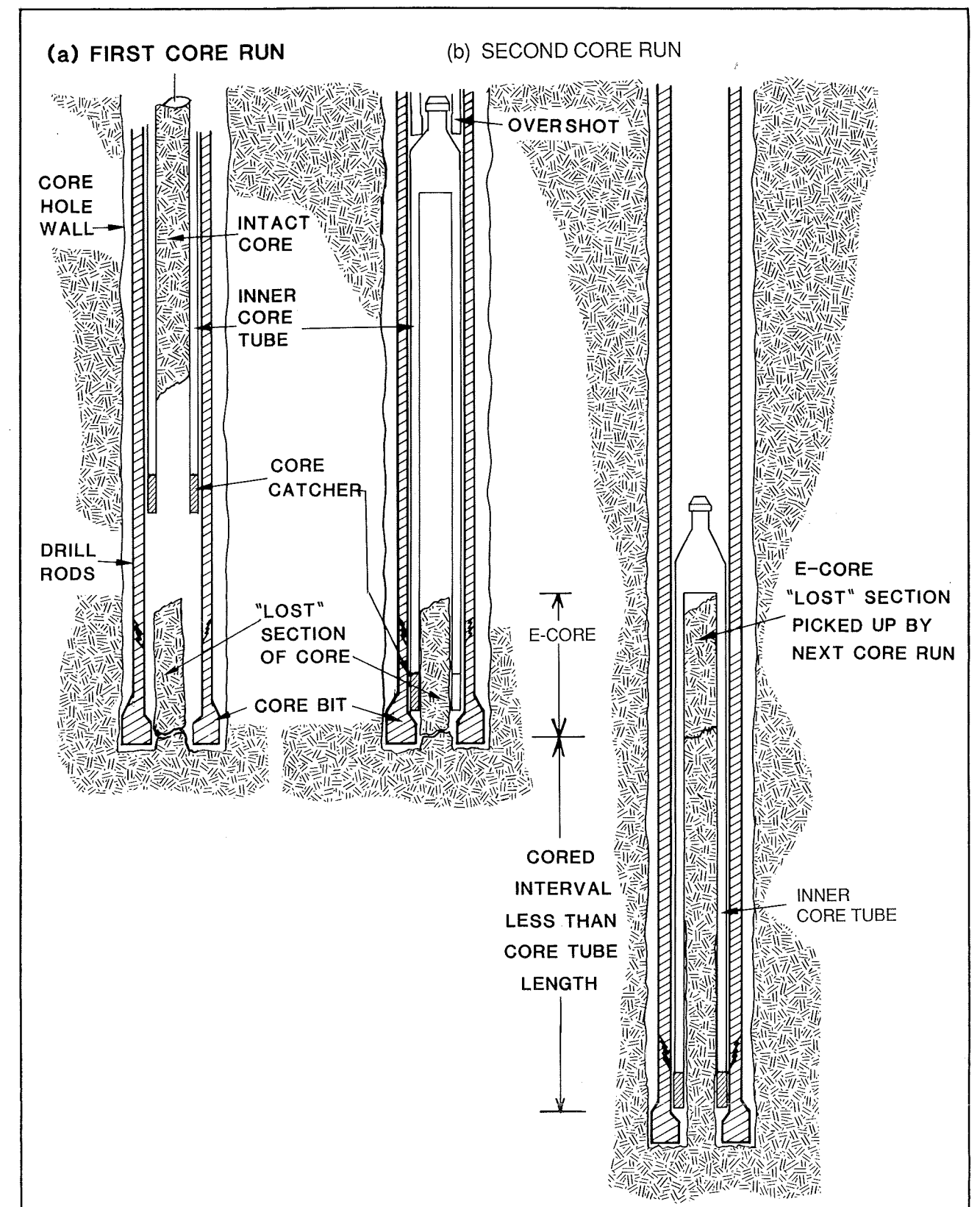

Fig. A-4.
Example of extra core (E-Core).

REFERENCES

- Dey, T., R. Kranz, and D. Holcomb, "Stress Measurement from Valles Caldera Core Hole No. 1," EOS Trans. AGU 65, no. 45, 1119 (1984).
- Doell, R. R., G. B. Dalrymple, R. L. Smith, and R. A. Bailey, "Paleomagnetism, Potassium-Argon Ages, and Geology of Rhyolites and Associated Rocks of the Valles Caldera, New Mexico," in Studies in Volcanology - A Memoir in Honor of Howell Williams, Geological Society of America Memoir 116, 211-248 (1968).
- Dondanville, R. F., "Geologic Characteristics of the Valles Caldera Geothermal System, New Mexico," in J. Combs (Chairperson), Geothermal Energy: A Novelty Becomes Resource, Geothermal Resources Council, 1978 Annual Meeting, Hilo, Hawaii, July 25-27, 1978 (Geothermal Resources Council, Davis, California), Union Oil Company of California, Santa Rosa, California, report CONF-780708-P1, 2, 157-160 (1978).
- Gardner, J. N., "Tectonic and Petrologic Evolution of the Keres Group: Implications for the Development of the Jemez Volcanic Field, New Mexico," Ph.D. dissertation, Univ. California, Davis, 293 p. (1985).
- Goff, F., J. Rowley, J. Gardner, W. Hawkins, S. Goff, R. Charles, L. Pisto, A. White, J. Eichelberger, and L. Younker, "Valles Caldera #1, a 856 m Core Hole in the Southwestern Ring-Fracture Zone of Valles Caldera, New Mexico," EOS Trans. AGU 65, no. 45, 1096 (1984).
- Goff, F. E., C. O. Grigsby, P. E. Trujillo Jr., D. Counce, and A. Kron, "Geology, Water Geochemistry and Geothermal Potential of the Jemez Springs Area, Cañon de San Diego, New Mexico," J. Volc. Geotherm. Res. 10:1-3, 227-244 (1981).
- Goff, F. E., and C. O. Grigsby, "Valles Caldera Geothermal Systems, New Mexico, USA," in J. Lavigne and J. B. W. Day (Editors), Hydrogeothermal Studies: Thermal Characteristics and Physico-Chemical Behaviour of Underground Waters in Relation to the Components of Aquifers, 26th International Geological Congress, Paris, France, July 7-17, 1980, J. Hydrol. 56, 119-136 (1982).
- Goff, F. E., and A. Kron, "In-Progress Geologic Map of Cañon de San Diego, Jemez Springs, New Mexico, and Lithologic Log of Jemez Springs Geothermal Well," Los Alamos National Laboratory report LA-8276-MAP, scale 1:12,000 (1980).
- Goff, F. E., and A. C. Waters, "Continental Scientific Drilling Program Thermal Regimes: Comparative Site Assessment Geology of Five Magma-Hydrothermal Systems," Los Alamos Scientific Laboratory report LA-8550-OBES, 100 p. (1980).
- Goff, S., "Curatorial Policy Guidelines and Procedures for the Continental Scientific Drilling Program," Los Alamos National Laboratory report LA-10542-OBES, 23 p. (1986).
- Heiken, G. H., M. E. Ander, and T. J. Shankland (Compilers), Workshop on Exploration for Hot Dry Rock Geothermal Systems, Los Alamos, NM, USA, 21 June 1982, Los Alamos National Laboratory report LA-9697-C CONF-8206177, 89 p. (1983).
- Heiken, G., and F. Goff, "Hot Dry Rock Geothermal Energy in the Jemez Volcanic Field, New Mexico," J. Volc. Geotherm. Res. 15, 223-246 (1983).
- Kite, W., S. Self, F. Goff, and J. Wright, "Pliocene Explosive Silicic Volcanism in the Jemez Mountains, New Mexico," EOS Trans. Am. Geophys. Union 63, 1131 (1982).
- Laughlin, A. W., "The Geothermal System of the Jemez Mountains, New Mexico, and Its Exploration," in L. Rybach and L. J. P. Muffler (Editors), Geothermal Systems: Principles and Case Histories, Wiley Press, New York, 295-320 (1981).
- Laughlin, A. W., A. C. Eddy, R. Laney, and M. J. Aldrich, Jr., "Geology of the Fenton Hill, New Mexico, Hot Dry Rock Site," J. Volc. Geotherm. Res. 15, 21-41 (1983).
- Rowley, J. C., "Deep Drilling Technology for Hot Crystalline Rocks," International Symposium on Observation of the Continental Crust Through Drilling, Tarrytown, NY, USA, May 20-25, 1984, Los Alamos National Laboratory document LA-UR-84-2564 CONF-840572-4, 70 p. (1984).
- Smith, R. L., and R. A. Bailey, "Stratigraphy, Structure, and Volcanic Evolution of the Jemez Mountains, New Mexico," Geological Society of America special paper 115, 447-448 (1968).
- Smith, R. L., R. A. Bailey, and C. S. Ross, "Geologic Map of Jemez Mountains, New Mexico," USGS Misc. Geol. Invest., Map I-571, scale 1:125,000 (1970).
- Swanberg, C., "Geothermal Resources of Rifts: A Comparison of the Rio Grande Rift and the Salton Trough," Tectonophysics 94, 659-678 (1983).
- Tester, J. W., "Review of Fenton Hill (Site-1) Experiments to Date," in J. C. Rowley (Compiler), Summary of Talks, 2nd Annual Hot Dry Rock Geothermal Conference, Santa Fe, NM, USA, Sept. 17-18, 1979, Los Alamos National Laboratory publication LASL-79-86, 3 p. (1979).
- Trainer, F. W., "Mixing of Thermal and Nonthermal Waters in the Margin of the Rio Grande Rift, Jemez Mountains, New Mexico," New Mexico Geological Society, Guidebook of Annual Field Conference 26, 213-218 (1975).
- USGS, "Geothermal Resources Operational Orders (GROO)," USDO, Office of Area Geothermal Supervision, GROO-1 Exploratory Operations, GROO-3, Plugging and Abandonment of Wells, GROO-4 General Environmental Protection Requirements, January 1976.

Printed in the United States of America
Available from
National Technical Information Service
US Department of Commerce
5285 Port Royal Road
Springfield, VA 22161

Microfiche (A01)

NTIS		NTIS		NTIS		NTIS	
Page Range	Price Code	Page Range	Price Code	Page Range	Price Code	Page Range	Price Code
001-025	A02	151-175	A08	301-325	A14	451-475	A20
026-050	A03	176-200	A09	326-350	A15	476-500	A21
051-075	A04	201-225	A10	351-375	A16	501-525	A22
076-100	A05	226-250	A11	376-400	A17	526-550	A23
101-125	A06	251-275	A12	401-425	A18	551-575	A24
126-150	A07	276-300	A13	426-450	A19	576-600	A25
						601-up*	A99

*Contact NTIS for a price quote.

Los Alamos