

(200)

R 290

74-1051

AL
500.1

Amex Exploration, Inc.
Geothermal Library

UNITED STATES DEPARTMENT OF THE INTERIOR
GEOLOGICAL SURVEY

Evaluation of Audio-magnetotelluric
Techniques as a Reconnaissance
Exploration Tool in Long Valley,
Mono and Inyo Counties,
California

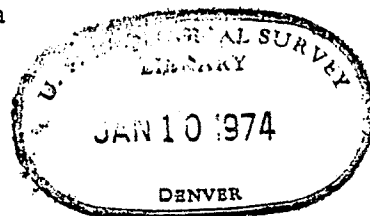

By

D. B. Hoover, F. C. Frischknecht, and C. L. Tippens

Open-file report

1973

Press release 1-24-74

This report is preliminary and has not been edited or reviewed for conformity with U.S. Geological Survey standards and nomenclature.

FEB 12 1975

Contents

	Page
Introduction-----	1
Basis of the technique-----	1
Equipment-----	4
Field operations-----	4
Results-----	6
Summary-----	10
References-----	11

Illustrations

[Plates are in pocket]

Plates 1-7. Maps of Long Valley, California:

1. AMT station locations and generalized geology.
2. 26-Hz apparent resistivity (east-west electric dipole).
3. 26-Hz apparent resistivity (north-south electric dipole).
4. 8-Hz apparent resistivity.
5. 86-Hz apparent resistivity.
6. 270-Hz apparent resistivity.
7. 7,000-Hz apparent resistivity.

8-9. AMT pseudosections along section A-A':

8. East-west electric dipole
9. North-south electric dipole.

10-11. Skin-depth pseudosections along section A-A':

10. East-west electric dipole.
11. North-south electric dipole.

	Page
Figure 1. Diagram of audio-magnetotelluric system-----	5
2-27. AMT soundings, Long Valley (Nos. 1-6 and 13-32)-----	13-38

Evaluation of audio-magnetotelluric techniques as a
reconnaissance exploration tool in Long Valley,

Mono and Inyo Counties, California

By D. B. Hoover, F. C. Frischknecht, and C. L. Tippens

Introduction

The audio-magnetotelluric technique (AMT) has been suggested as a useful tool for reconnaissance exploration of conductive anomalies in geothermal areas. To access the potential of the technique, AMT studies were made in the Long Valley caldera where extensive geological and geophysical studies provided adequate background information (Bailey, Lanphere, and Dalrymple, 1973; Hill, McHugh, and Pakiser, 1973; Kane and Mabey, 1973; Lackenbruch, Lewis, and Sass, 1973; Willey, Rapp, and Barnes, 1973; Stanley, Jackson, and Zohdy, 1973; Anderson and Johnson, 1973; Iyer and Hitchcock, 1973; Steeples and Pitt, 1973). In particular the geological work of Bailey, Lanphere, and Dalrymple (1973), and electrical studies of Stanley, Jackson, and Zohdy (1973) provided principal control for evaluation of the technique.

As no commercial equipment is available as a package, the results reported here were obtained from equipment and field techniques developed by the Geological Survey. These methods and techniques should be considered only preliminary as modifications to both equipment and operations are continuing as experience is gained.

Basis of the technique

The magnetotelluric method is one of three electromagnetic exploration techniques in which naturally occurring electromagnetic fields are used. The telluric and AFMAG (audio-frequency magnetics) methods are the other techniques, and all 3 suffer from being dependent upon vagaries in the natural fields as anyone who has worked with the techniques knows. In this work the frequency range used was from 8 Hz to 18.6 KHz and the technique is accordingly called audio-magnetotelluric exploration. This range of frequencies provides exploration depths of interest in minerals exploration and spans the frequency range in which AFMAG measurements are made.

In using the AMT method it is assumed that the sources of energy are plane electromagnetic waves propagating essentially vertically downward into the earth. For the plane wave assumption to be valid the source must be at a distance greater than about four skin depths. The downward propagating plane wave consists of mutually perpendicular horizontal magnetic and electric fields. If the earth consists of homogeneous horizontal layers the electric field in the earth is radial to the source and the magnetic field is tangential to the source. It should be noted that above the earth ELF (extra low frequency) and VLF (very low frequency) energy propagates for long distances around the earth in the cavity or wave guide formed by the earth and the ionosphere. The fields above the earth are approximately plane waves at grazing incidence. For a homogeneous or horizontally stratified earth the apparent resistivity of the earth is a function of these fields and is given by (Cagniard, 1953):

$$\rho_a = \frac{1}{5f} \frac{|E|^2}{|H|^2} \quad (1)$$

f = frequency in Hertz
 E = electric field in microvolts/meter
 H = magnetic field in gammas
 ρ_a = apparent resistivity in ohm-meters

As the apparent resistivity is a function of frequency, a means is provided for determining the variation of resistivity with depth. As the electromagnetic energy propagates into the earth it is attenuated. The depth at which the current density falls to $\frac{1}{e}$ of its surface value is called the skin depth and provides an approximate measure of the depth of exploration. Thus if the apparent resistivity is measured as a function of frequency a sounding is made much as in direct-current geometric sounding (Keller and Frischknecht, 1966).

For rocks which are not strongly magnetic the skin depth, δ , is given by

$$\delta = 503 \sqrt{\rho/f} \text{ meters, where } \rho \text{ is in ohm-meters} \quad (2)$$

For example, with our equipment, if measurements were made over a 100 ohm-meter earth we would be measuring the bulk properties from the surface to a depth of approximately 37 meters at 18.6 KHz and to 1800 meters at 8 Hz.

The source for the observed electromagnetic energy is from world wide lightning storms. Storms in tropical regions account for the preponderance of the energy. Bleil (1964) and Ward (1967) discuss the temporal and spacial variations of these storm signals. The main feature of interest here are the weakness of signals during the winter months, and the nonuniformity of thunderstorm centers from day to day. The decrease in energy makes operations difficult or impractical during winter months. The nonuniformity in source position gives some data scatter or nonrepeatability of data depending on source location and lateral resistivity variations (Strangway and Vozoff, 1970). This is more apparent at the higher frequencies. The energy from the storm centers propagates in the earth-ionosphere wave guide which has its first resonant mode at about 8 Hz. For about a decade below this frequency the energy is weak enough to be impractical to use in reconnaissance exploration. The frequency dependence of the wave guide produces a region of low signal strength around 2,000 Hz, and limits data acquisition in this band. In our operations we seldom obtained usable data at 2,000 Hz, and in late October energy was often too weak to use at 700 Hz.

Within the AMT frequency band, manmade signals are also present. Most troublesome are powerline radiations, their harmonics, and in the higher ranges, VLF radio stations. These latter signals may be used, and, in our equipment, VLF stations at 10.2 KHz and 18.6 KHz are employed. During the rare periods when the transmitters are off, natural energy is sufficient for operations. In the field, however, it would be difficult to insure for powerline radiations that the source distance was at least four skin depths without severely restricting operations to remote regions. Thus the large amount of radiation from powerlines generally constitutes only a difficult noise problem. With our present equipment we prefer to operate no closer than 1 km from powerlines, although equipment modifications are underway to permit closer operations.

Equipment

Figure 1 shows a diagram of our instrumentation. To measure the electric field two steel stakes are used as electrodes, generally separated by 100 meters. The electric field signal is amplified and prefiltered using R-C bandpass filters so as to prevent limiting of strong transients in the early stages. Narrow band active notch filters are used to remove 60 and 180 Hz powerline signals. The signals then enter a universal active filter connected in a high-Q bandpass configuration. Approximately constant Q is maintained at all filter settings. The 6 db bandwidth at 8 Hz is 0.3 Hz; 9 selectable frequencies are used to define a sounding curve spaced logarithmically throughout the band, but selected so as to avoid midband harmonics of 60 Hz. At present our operating frequencies are 8, 26, 86, 270, 700, 2,000, 7,000, 10,200 and 18,600 Hz. The output of this narrow band filter is rectified, integrated, and displayed on a strip chart recorder to show the envelope of the received energy. Maximum system gain will provide about 30.0 mm chart deflection for a 1 microvolt signal.

An induction pickup is used for the magnetic field sensor, consisting of a ferrite core upon which are wound many thousands of turns of wire. In order to span the broad range of frequencies we have found it necessary to use two separate coils. One covers the range of 8 to 700 Hz and the other 2 KHz to 18.6 KHz. An integral part of each coil is a low noise preamplifier which feeds the magnetic field signal to a second channel, essentially similar to that described for recording the electric field. Coil sensitivity is about 0.1 microvolt per milligamma at 8 Hz.

Phase information is preserved by means of a phase-locked loop and synchronous detectors as shown in figure 1. The usefulness of the phase information is still being evaluated so no further discussion of it will be made in this report.

Field operations

The strip-chart recorder and high gain selective filters are operated from the back end of a carryall truck with power supplied by an inverter connected to the truck battery. The coil and common electrode of the electric line are located 100 ft from the truck to avoid electrical noise

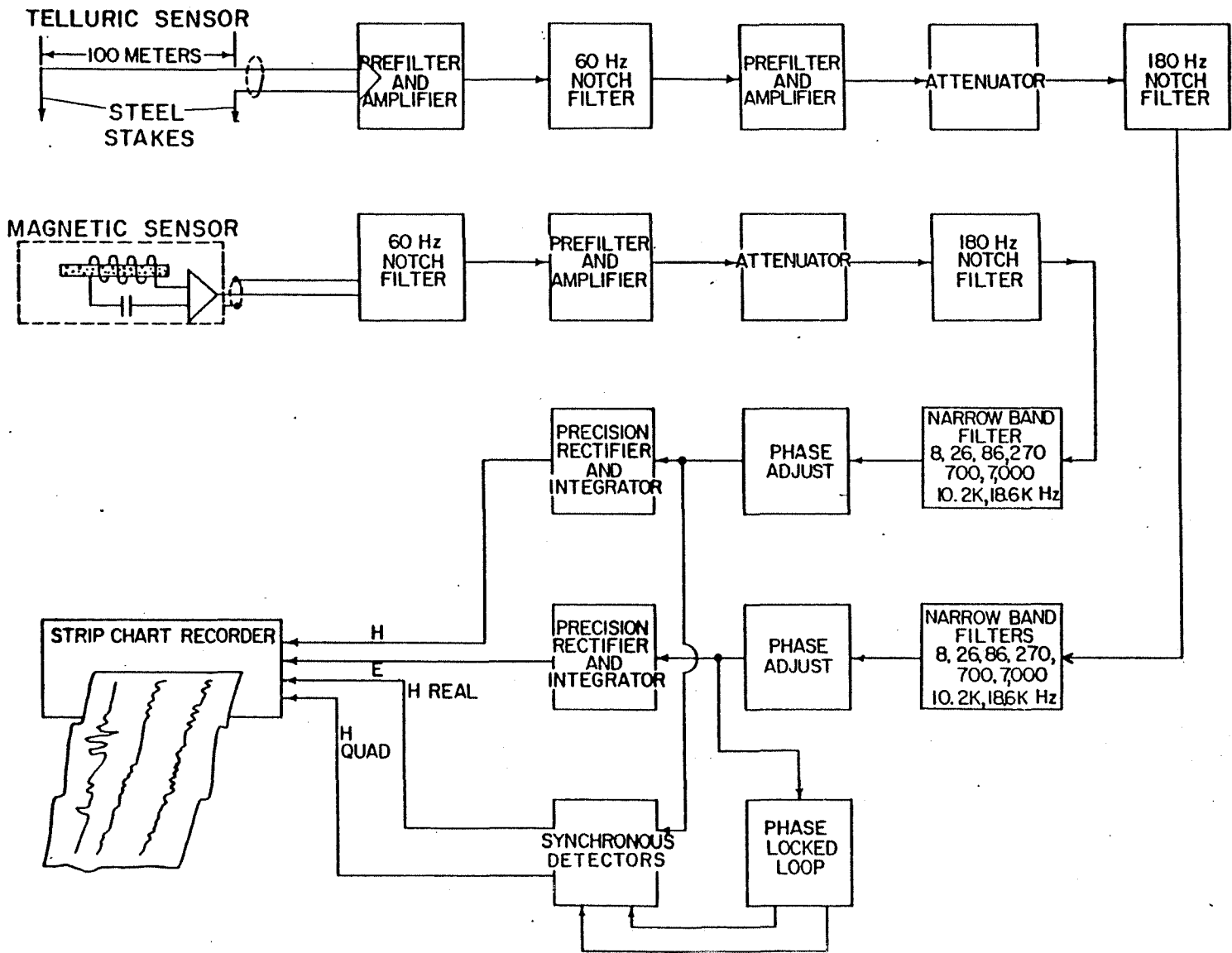

Figure 1.--USGS audio-magnetotelluric (AMT) system.

from the vicinity of the truck. Signals are brought to the truck over coaxial cable.

The electric line is laid out in either an east-west or north-south direction and the coil placed at a right angle. System gains are adjusted so as to give 20 to 40 mm chart deflection of peak energy bursts on each channel. The amplitude of corresponding electric and magnetic signals are measured and their ratio computed for a sufficient number of signals so that a reliable average ratio is obtained. The Cagniard resistivity is then computed from a knowledge of system gain and equation 1.

Data is computed and plotted in the field while recording is underway giving a sounding curve by switching through the various frequencies. The electric dipole and coil are then rotated 90 degrees, and a second sounding made and plotted. This permits the operators to correct any obvious errors and to check any data points that appear aberrant. The second sounding also provides information on lateral variations in conductivity or anisotropy of the earth.

Operations are made by two persons, one acting as observer and the other acting as computer. Typical production is 8 soundings or 4 stations per day. Most of the time is spent waiting for a sufficient number of strong signals so as to provide good statistics on the ratio of E to H. Our experience has shown that the 8 Hz signals are often insufficient to provide good statistics; 26, 86, and 270 Hz signals are always good; 700 Hz signals tend to be variable; 2 KHz signals virtually nonexistent; and 7 KHz and greater the signals are very good.

Results

Figures 2-27 are the AMT sounding curves obtained in the Long Valley caldera. Station locations are shown on plate 1. The soundings are plotted on a logarithmic base with the frequency increasing to the left, contrary to conventional use. They are similar in appearance to a Schlumberger sounding curve and hence permit easier reference to the work of Stanley, Jackson, and Zohdy (1973) in Long Valley. Examination of the AMT sounding curves shows the data scatter that is inherent in the method when soundings at one site are compared for both east-west and north-south

orientation of the electric dipole. This data scatter is dependent on station location and in part reflects lateral variations in resistivity.

Some sounding locations such as stations AMT 14 and 16 show consistent variations in apparent resistivity between east-west and north-south sensor orientations. These differences are due to major lateral variations which may be produced by fault zones oriented subparallel to one of the sensors. The absence of these consistent variations, however, doesn't necessarily imply the absence of lateral inhomogeneities.

As Strangway and Vozoff (1970) have pointed out, the AMT method, as it is an inductive technique, is excellent for locating conductors because it tends to "look through" high resistivity material. This is the reason for its application in geothermal exploration. However, as Strangway and Vozoff also point out, its depth resolution suffers accordingly. An intermediate layer of higher resistivity sandwiched between two lower ones can easily be undetected as a low velocity layer can be undetected in seismic refraction work.

Strangway and Vozoff also note that in practice many more lateral variations appear in AMT work than are perhaps expected. This also is evident in the Long Valley soundings. Even some soundings which, at first glance, appear consistent in both east-west and north-south directions do not give horizontal layer interpretation in terms of reasonable layer resistivities. This is evident from the slope of the sounding curves.

These problems suggest that the AMT method might best be used as a reconnaissance technique to look for the location of major conductive anomalies. However workers should not put too much reliance on it for definitive depth information. Also, as is found for the AFMAG method, the AMT method would be expected to detect fault zones along which conductive zones tend to concentrate the telluric currents. Because of these problems, data presentation in Long Valley has been limited to the preparation of a series of anomaly maps at several frequencies and some pseudosections.

In principle, one could assume that the earth is not horizontally stratified and attempt to interpret the AMT soundings in terms of

three-dimensional models. In practice, techniques for solving the forward problem of three-dimensional modelling are just now being developed and it will be some time before we learn to quantitatively interpret AMT data in terms of complex models.

Plate 1 shows the location of 26 sounding stations occupied in the caldera and the hot springs and fault patterns taken from Bailey, Lanphere, and Dalrymple (1973). One of the major features seen on this map is the branching of the Hilton Creek fault to the northwest as it leaves the Sierra block near Whitmore Hot Springs, with many of the inter-caldera branches trending to the north and northwest across the resurgent dome.

Plates 2 and 3 are maps of the apparent resistivity variations at 26 Hz for orientation of the electric field dipole east-west and north-south respectively. The differences reflect the effect of lateral inhomogeneities within the caldera. In a gross sense, conductors oriented subparallel to the electric line will tend to give lower values than conductors at right angles to the electric line. This is complicated by current concentration within the conductor and one finds resistivity highs associated with the ends of conductors. The anomaly pattern reflects in a gross way, but not in detail, the position and shape of the conductors.

In view of the low station density, plate 2 shows an anomaly pattern remarkably similar to the total field resistivity anomaly of Stanley, Jackson, and Zohdy (1973). A small closed low is seen at Casa Diablo Hot Springs and an elongate low which trends northwest near the Cashbaugh Ranch. It should be noted on these maps that resistivity contouring is based on a logarithmic scale. The Cashbaugh Ranch low however is much more restricted in area to the northeast than is indicated on the total field map. The reason for this difference is not entirely clear but is related at least in part to the structural complexities in this region as discussed by Stanley, Jackson, and Zohdy (1973).

Plate 3 shows the 26 Hz data for a N-S orientation of the electric dipole. Again the general pattern is the same as plate 2. It shows a V-shaped low with one arm east-west and the other northwest and the center about where the Hilton Creek fault enters the caldera. The low is now centered on a hot spring just north of the Whitmore Hot Springs. The

differences in plates 2 and 3 are due to lateral resistivity variations, and some inferences can be made regarding the conductor orientation. Stations 16 and 14 primarily define the east-west low in plate 3; however, the magnitude of the apparent resistivity is much lower at these stations where the electric dipole is oriented north-south rather than east-west. These data imply that the conductor has a generally north-south trend. By referring to plate 1 it can be seen that these stations are very close to north-trending faults.

Examination of all the sounding curves shows that at the lower frequencies most conductors tend to have a more north-south orientation and only in a few cases, as soundings 21 and 22, is an east-west orientation indicated.

The southern edge of the surveyed area near the caldera boundary clearly shows by the abrupt increase in resistivity the presence of the basement rocks associated with the Sierra front.

Plates 4 through 7 show apparent resistivity maps of 8, 86, 270, and 7,000 Hz. Where substantial differences were measured between the two orientations of the electric dipole an average value of apparent resistivity was plotted. These figures show very similar trends to the two 26 Hz maps (pls. 2 and 3). The 8 Hz map (pl. 4), which is looking deeper than the others, has a greater similarity to the total field map of Stanley and others, particularly if the sounding data is examined. At the higher frequencies the flows associated with the resurgent dome become more apparent by the high resistivity values on the northwest end of the mapped area.

Plate 7 represents the near surface resistivity variations, but the sampling density is very poor as at this high frequency a relatively small volume is being measured. This map shows a strong east-west orientation of the low resistivity area running from Casa Diablo to Lake Crowley. The low resistivity probably indicates the region where hot-spring activity has caused most of the near surface alteration.

In magnetotelluric work, electrical cross sections are often used as aids to interpret variations of electrical properties with depth. These are usually called pseudosections and plotted with frequency

decreasing downward on a logarithmic scale. Plates 8 and 9 are pseudosections along section A-A', oriented approximately north-south through Whitmore Hot Springs. The two sections are plotted for east-west and north-south orientation of the electric dipole. The sections clearly show a vertical low resistivity feature at station 14. This low is interpreted to be a fault zone along which thermal waters are rising and along which extensive alteration has taken place.

An obvious disadvantage of these pseudosections is that they give a very distorted idea of the depth of exploration at each data point. For instance, at station 27 the depth from which information is obtained is about 5 times deeper than at station 14. An alternative presentation is shown in plates 10 and 11 in which the skin depth is plotted on the vertical axis corresponding to a measured apparent resistivity and frequency. These are still pseudosections in that they do not represent an analytical solution in terms of a resistivity-depth model. Their justification is in their reduced distortion of the resistivity section.

These skin-depth pseudosections illustrate the ability of AMT surveying to look through large thicknesses of high resistivity rock as on the south ends of the profiles (pls. 10 and 11) where depths of more than 2 km are sampled. They also clearly show the exploration limits where low resistivities are encountered. This difference in exploration depth should be kept clearly in mind when examining the anomaly maps (pls. 2-7). The low resistivity feature at station 14 still remains but its inferred depth range is clearly limited--a fact not directly apparent from plates 8 and 9.

Summary

The described AMT technique was developed for use as a reconnaissance geothermal exploration tool to search for conductive anomalies associated with hot saline waters and related altered rock. The exploration philosophy is that a relatively inexpensive technique would be followed by more definitive electrical techniques in appropriate areas. Long Valley was used as a test area for equipment and field-technique development described here.

The fieldwork was performed in one week by two persons, and therefore represents no large field effort. Cost of the survey is minimal. The

correspondence with the other detailed electrical work in Long Valley by Stanley and others is considered very good. In fact, if the AMT survey had been used to pinpoint an intensive exploration program, this area would not have significantly differed from that identified by the more detailed electrical methods. This study, at least for Long Valley, demonstrates the effectiveness of AMT as a reconnaissance technique and we believe clearly demonstrates that AMT is a cost-effective tool for reconnaissance exploration of geothermal areas. This was the major purpose for the work described here.

In terms of the geothermal potential of Long Valley, the hot water and associated altered zones appear from the AMT data to be restricted to a V-shaped area that extends from Casa Diablo east to Whitmore Hot Springs and then northwest to the head of Little Hot Creek. Within this area the hot springs and their alteration zones are concentrated along north- to northwest-trending fault zones. These fault zones appear to be channels along which hot waters leak from a more poorly defined deeper geothermal reservoir in the southwest part of the caldera. The AMT data implies that shallow exploration in Long Valley should be restricted to faults within the described V-shaped zone. The method offers little regarding deep exploration.

References

- Anderson, L. A., and Johnson, G. R., 1974, A self-potential survey of Long Valley caldera, Mono County, Calif.: U.S. Geol. Survey open-file rept.
- Bleil, D. F., 1964, Natural electromagnetic phenomena below 30 Kc/s: Plenum Press, 470 p.
- Bailey, R. A., Lanphere, M. A., and Dalrymple, G. B., 1973, Vulcanism and geochronology of Long Valley caldera, Mono County, Calif. [abs.]: EOS (Am. Geophys. Union Trans.), v. p. (in press).
- Cagniard, Louis, 1953, Basic theory of the magneto-telluric method of geophysical prospecting: Geophysics, v. 18, no. 3, p. 605-635.
- Hill, D. P., McHugh, S., and Pakiser, L. C., 1973, Structure of the Long Valley caldera from detailed seismic refraction measurements [abs.]: EOS (Am. Geophys. Union Trans.), v. p. (in press).

- Iyer, H. M., and Hitchcock, T., 1973, A seismic noise survey in Long Valley, Calif. [abs.]: EOS (Am. Geophys. Union Trans.), v. , p. (in press).
- Kane, M. F., and Mabey, D. R., 1973, Gravity and magnetic anomalies in Long Valley, Calif. [abs.]: EOS (Am. Geophys. Union Trans.), v. , p. (in press).
- Keller, G. V., and Frischknecht, F. C., 1966, Electrical methods in geophysical prospecting: Pergamon Press, 519 p.
- Lackenbruch, A. H., Lewis, R. E., and Sass, I. H., 1973, Prospecting for heat in Long Valley [abs.]: EOS (Am. Geophys. Union Trans.), v. , p. (in press).
- Stanley, W. D., Jackson, D. B., and Zohdy, A. A. R., 1973, Preliminary results of deep electrical studies in the Long Valley caldera, Mono-Inyo County, Calif.: EOS (Am. Geophys. Union Trans.), v. , p. (in press).
- Steeple, D. W., and Pitt, A. M., 1973, Microearthquakes in and near Long Valley, Calif. [abs.]: EOS (Am. Geophys. Union Trans.), v. , p. (in press).
- Strangway, D. W., and Vozoff, K., 1970, Mining exploration with natural electromagnetic fields, in Marly, L. W., ed., Mining and groundwater geophysics/1967: Ottawa, Queens Printer, p. 109-122.
- Ward, S. H., 1967, The electromagnetic method, in Mining Geophysics--v. 2, Theory: Tulsa, Okla., Soc. Explor. Geophysicists, p. 224-372.
- Willey, L. M., Rapp, J. B., and Barnes, Ivan, 1973, Geochemistry of thermal waters in Long Valley, Calif. [abs.]: EOS (Am. Geophys. Union Trans.), v. , p. (in press).

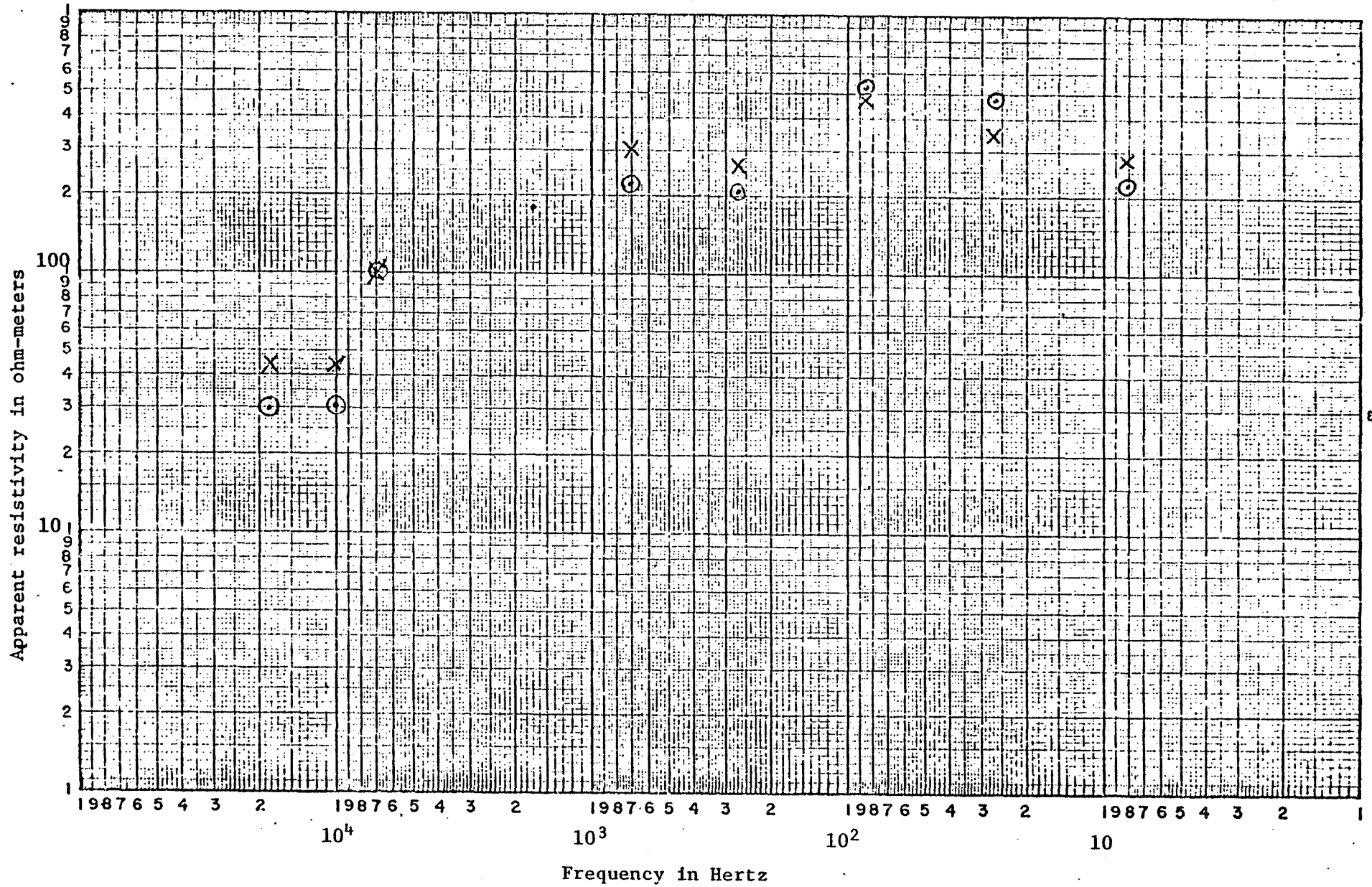

Figure 2. AMT sounding, Long Valley #1. x, electric line east, ⊙, electric line south.

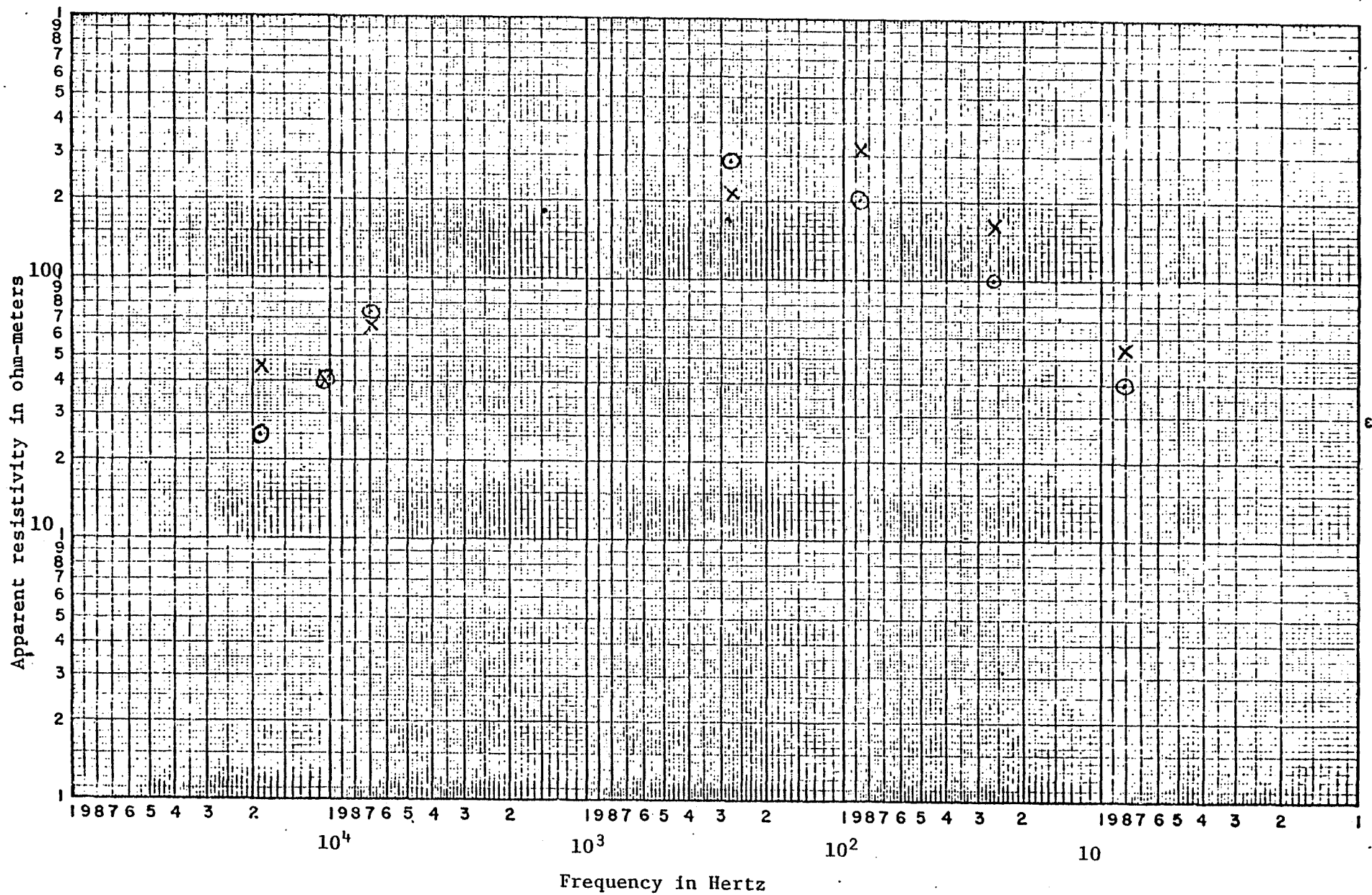

Figure 3. AMT sounding, Long Valley #2. x, electric line west, ⊗, electric line north.

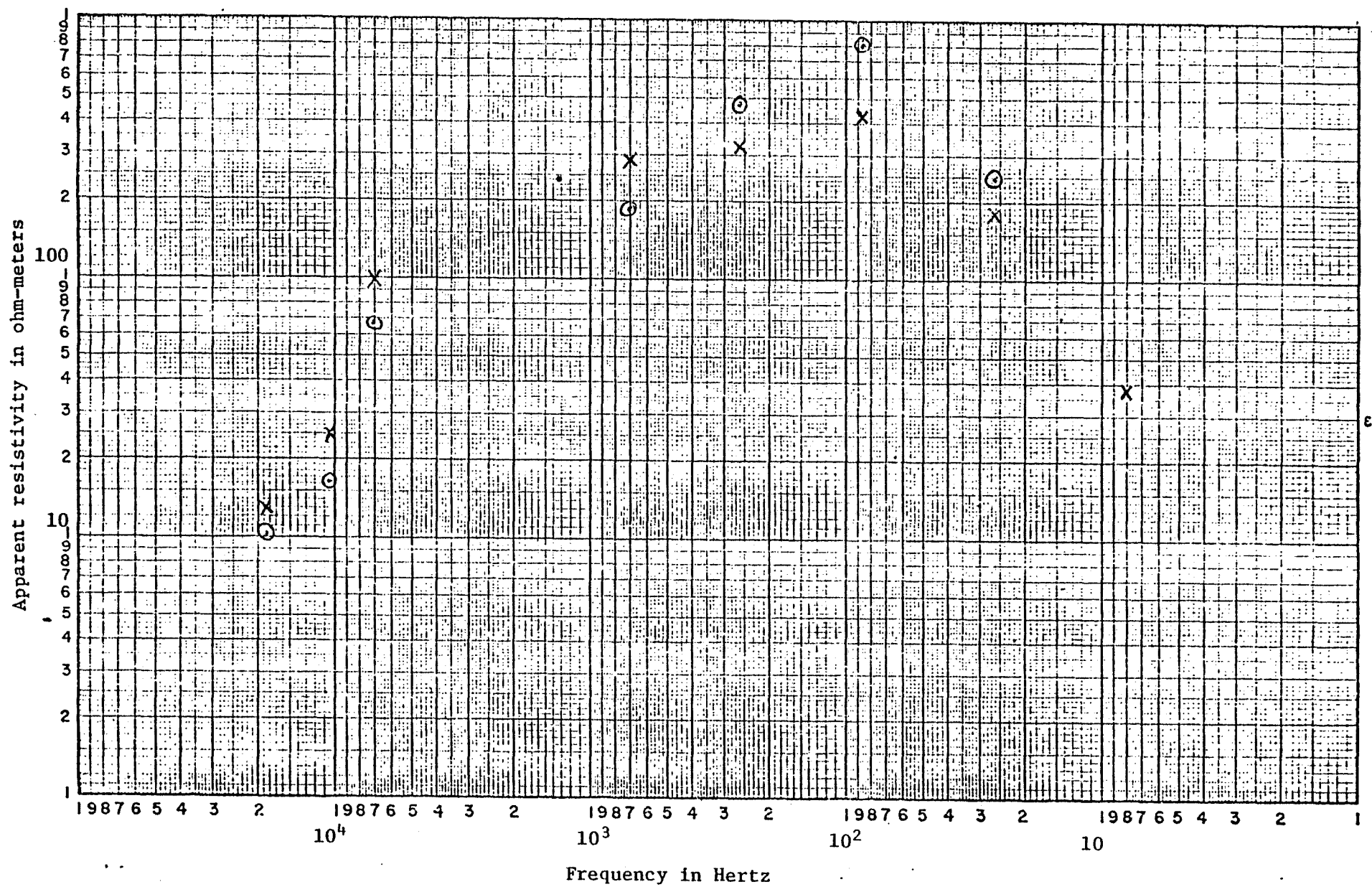

Figure 4. AMT sounding, Long Valley #3. x, electric line east, ⊙, electric line south.

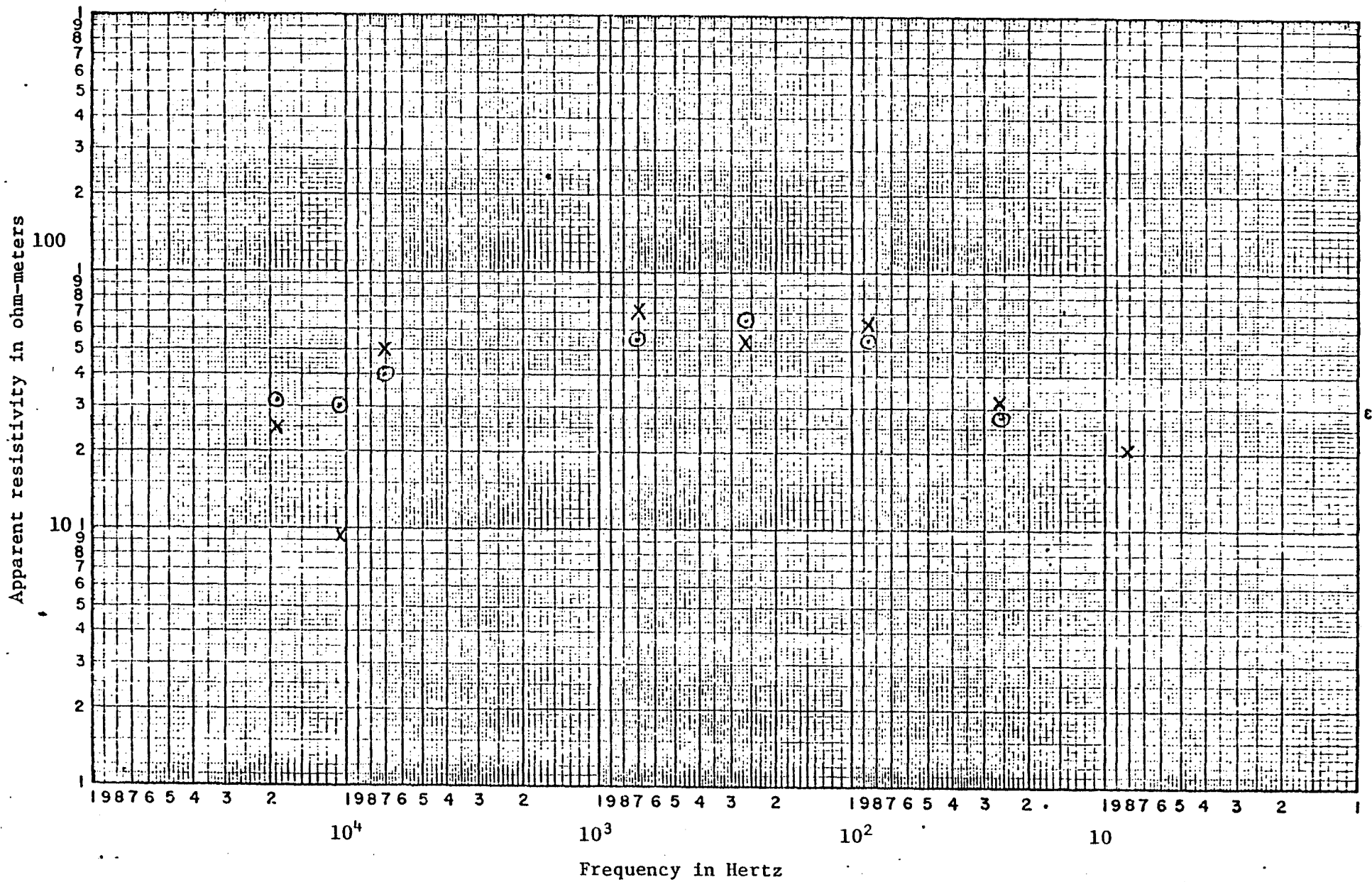

Figure 5. AMT sounding, Long Valley #4. x, electric line west, ⊙, electric line south.

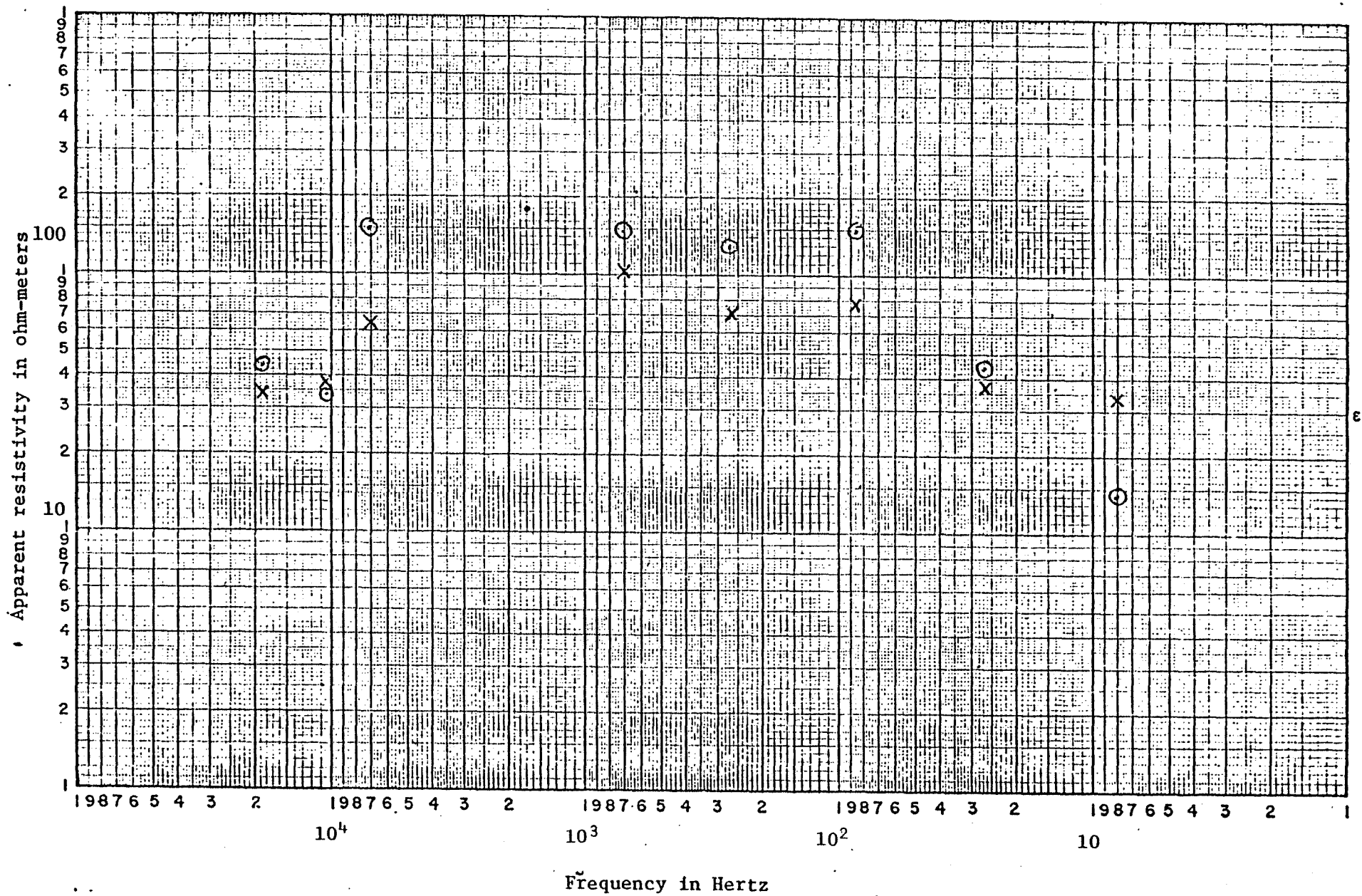

Figure 6. AMT sounding, Long Valley #5. x, electric line east, O, electric line south.

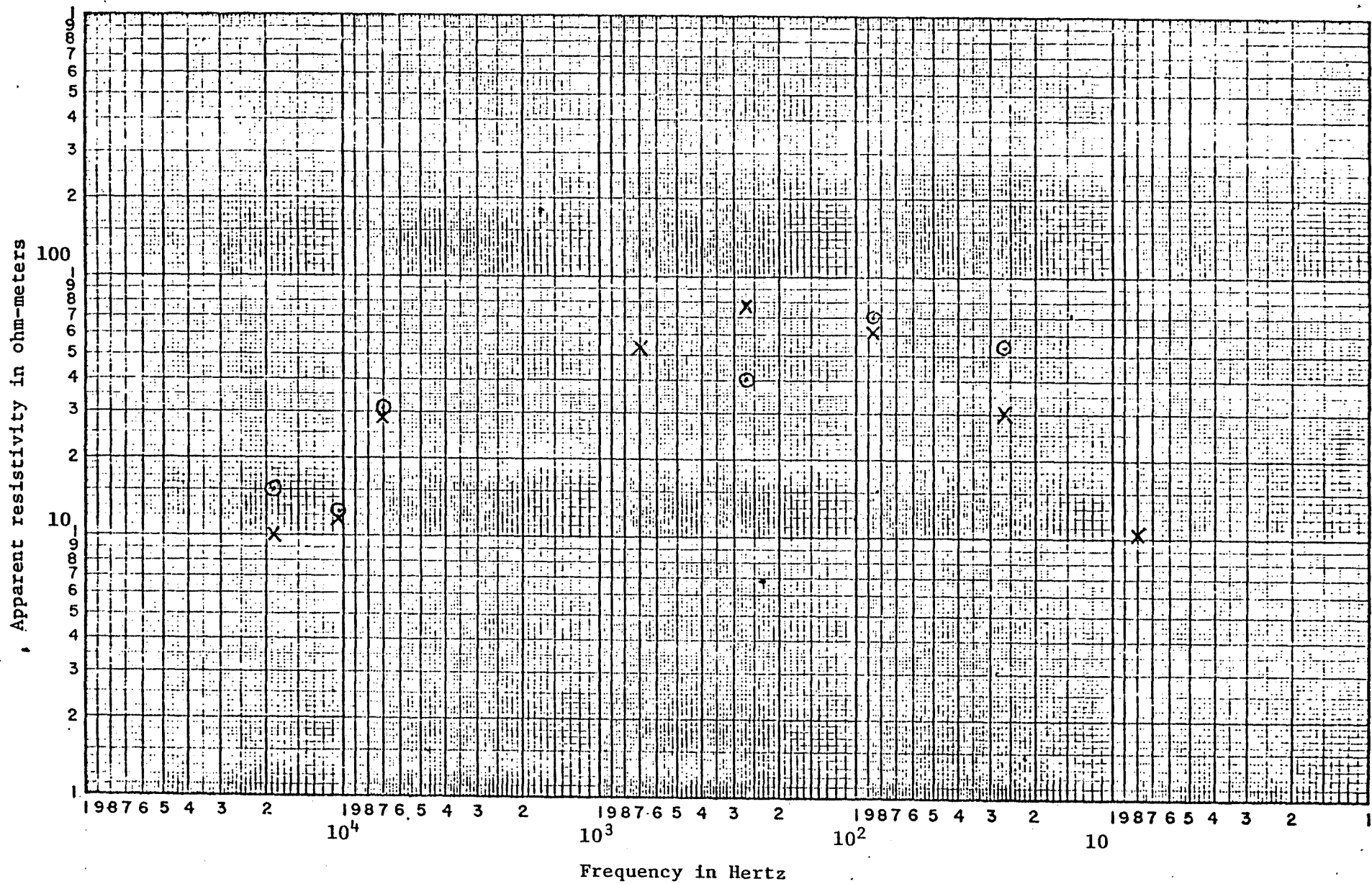

Figure 7. AMT sounding, Long Valley #6. x, electric line east, ⊙ electric line south.

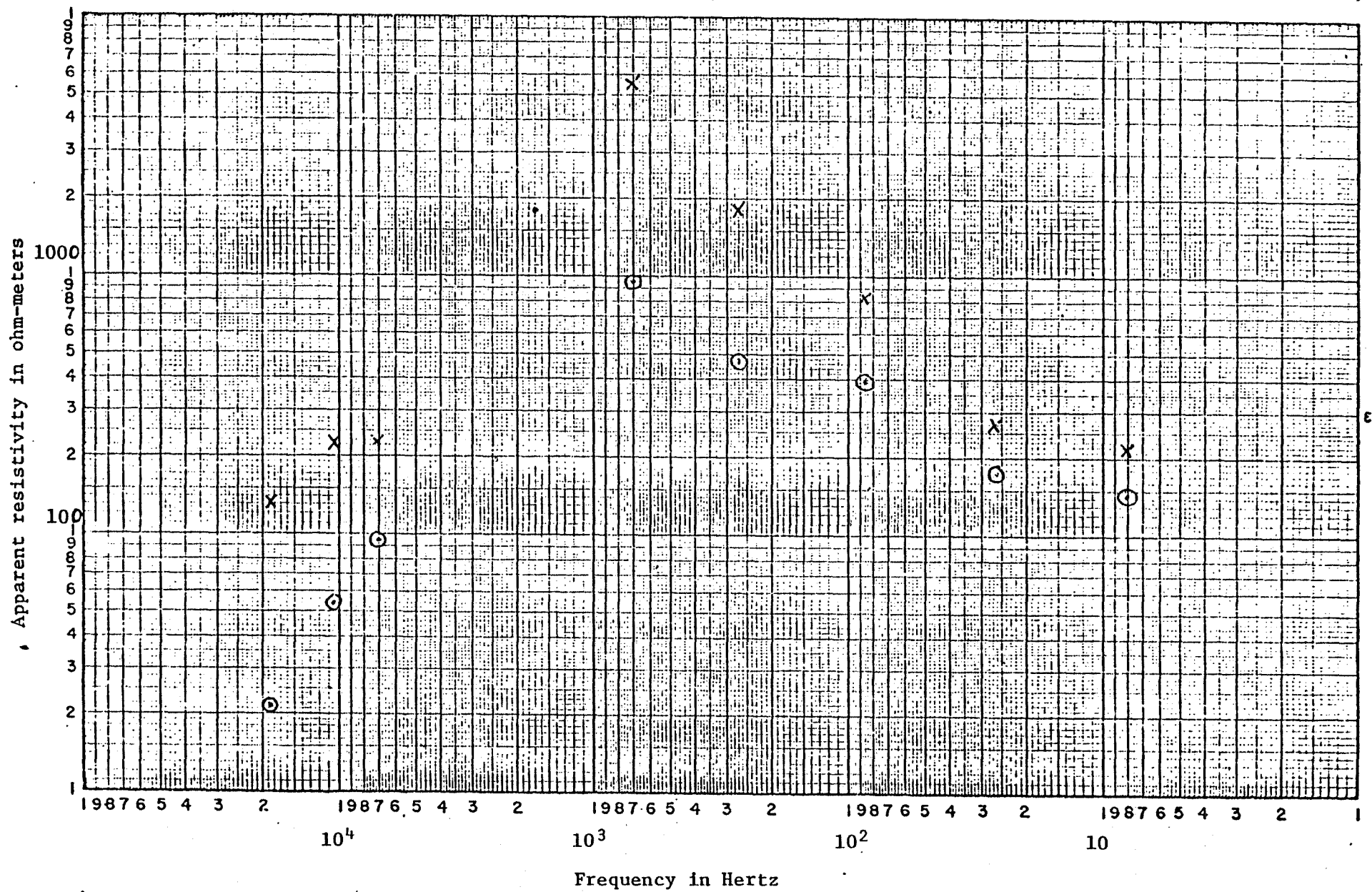

Figure 8. AMT sounding, Long Valley #13. x, electric line east, o electric line north.

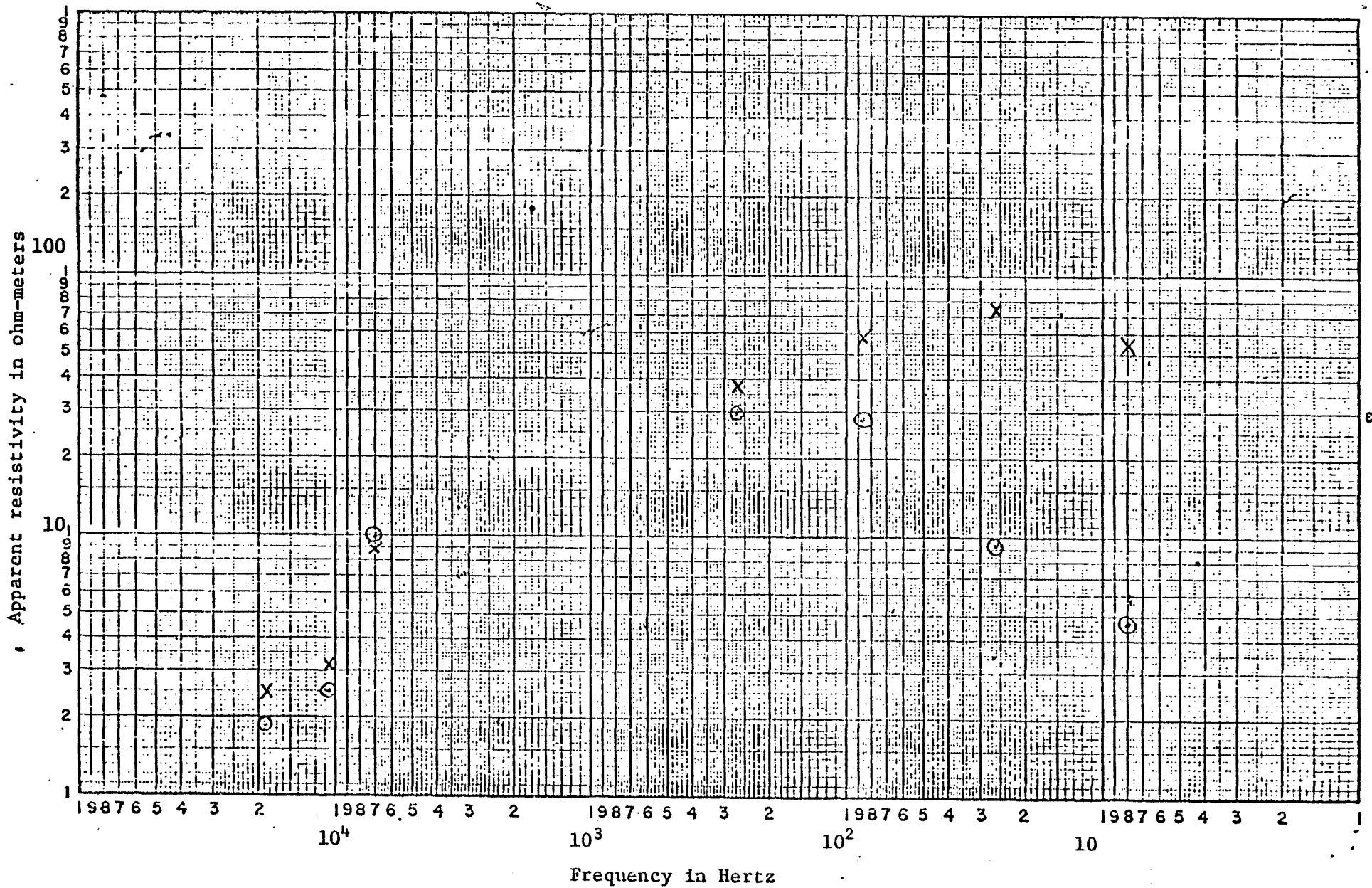

Figure 9. AMT sounding, Long Valley #14. x, electric line east, o, electric line south.

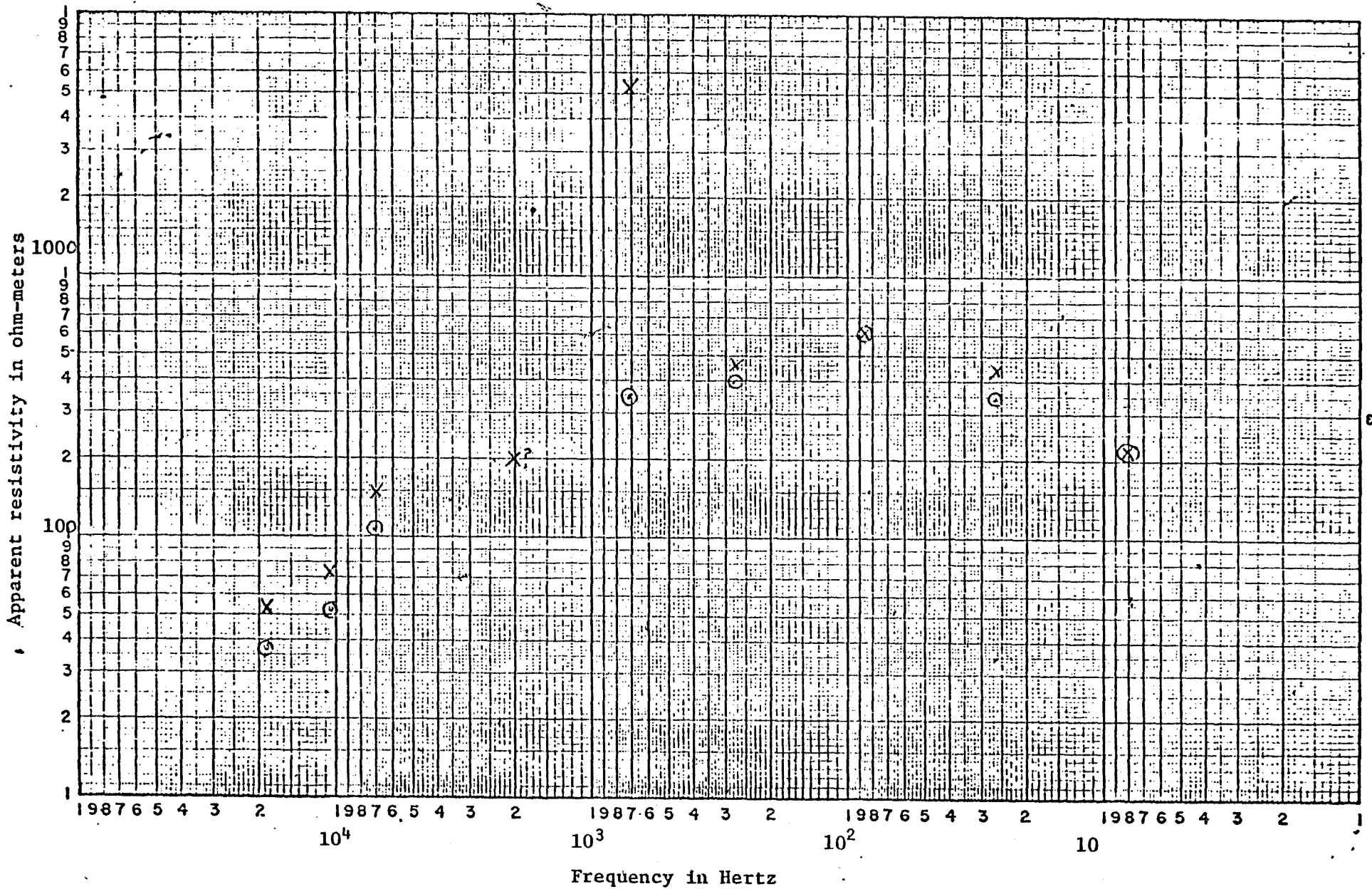

Figure 10. AMT sounding, Long Valley #15. x, electric line east, o, electric line south.

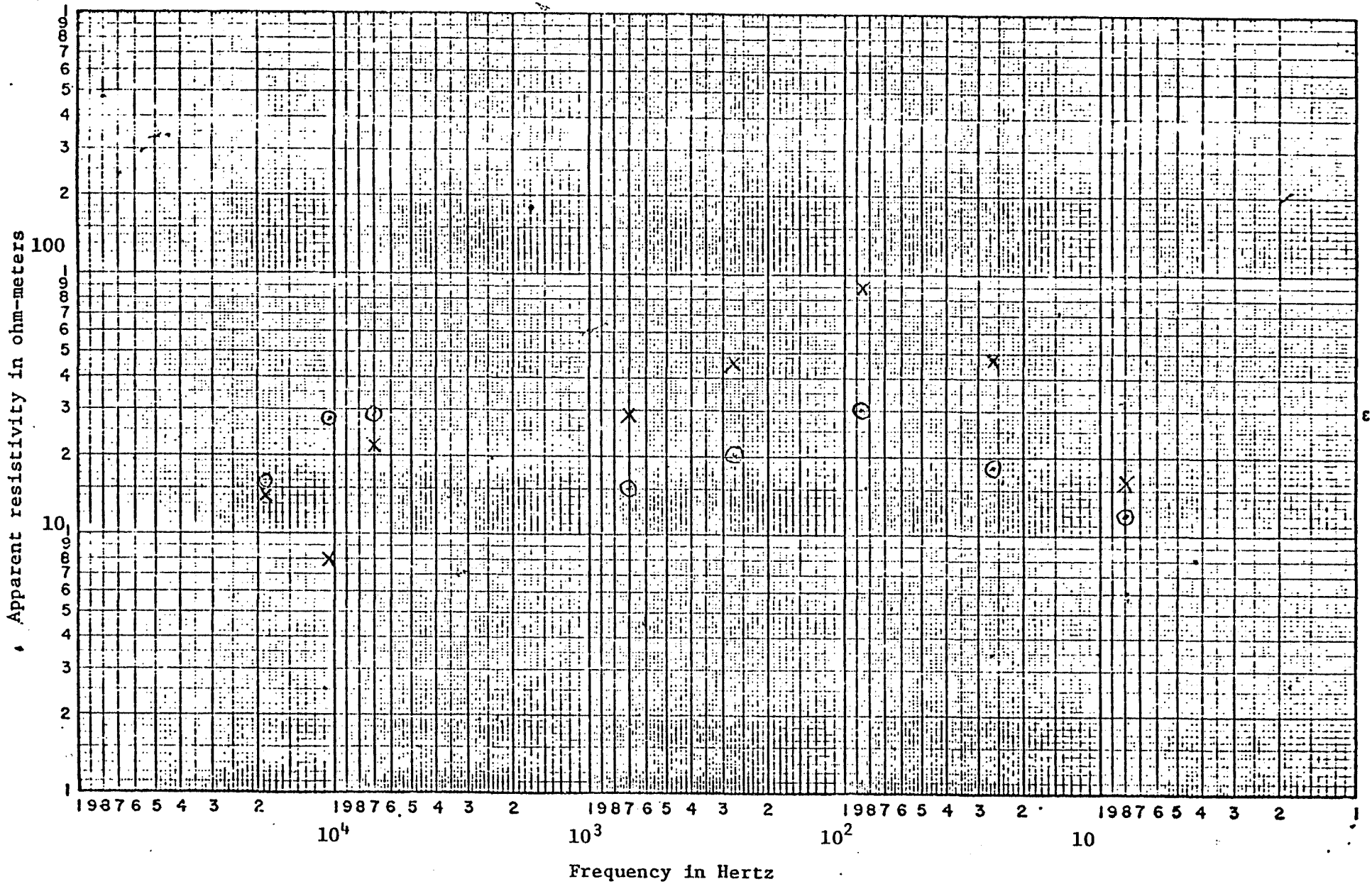
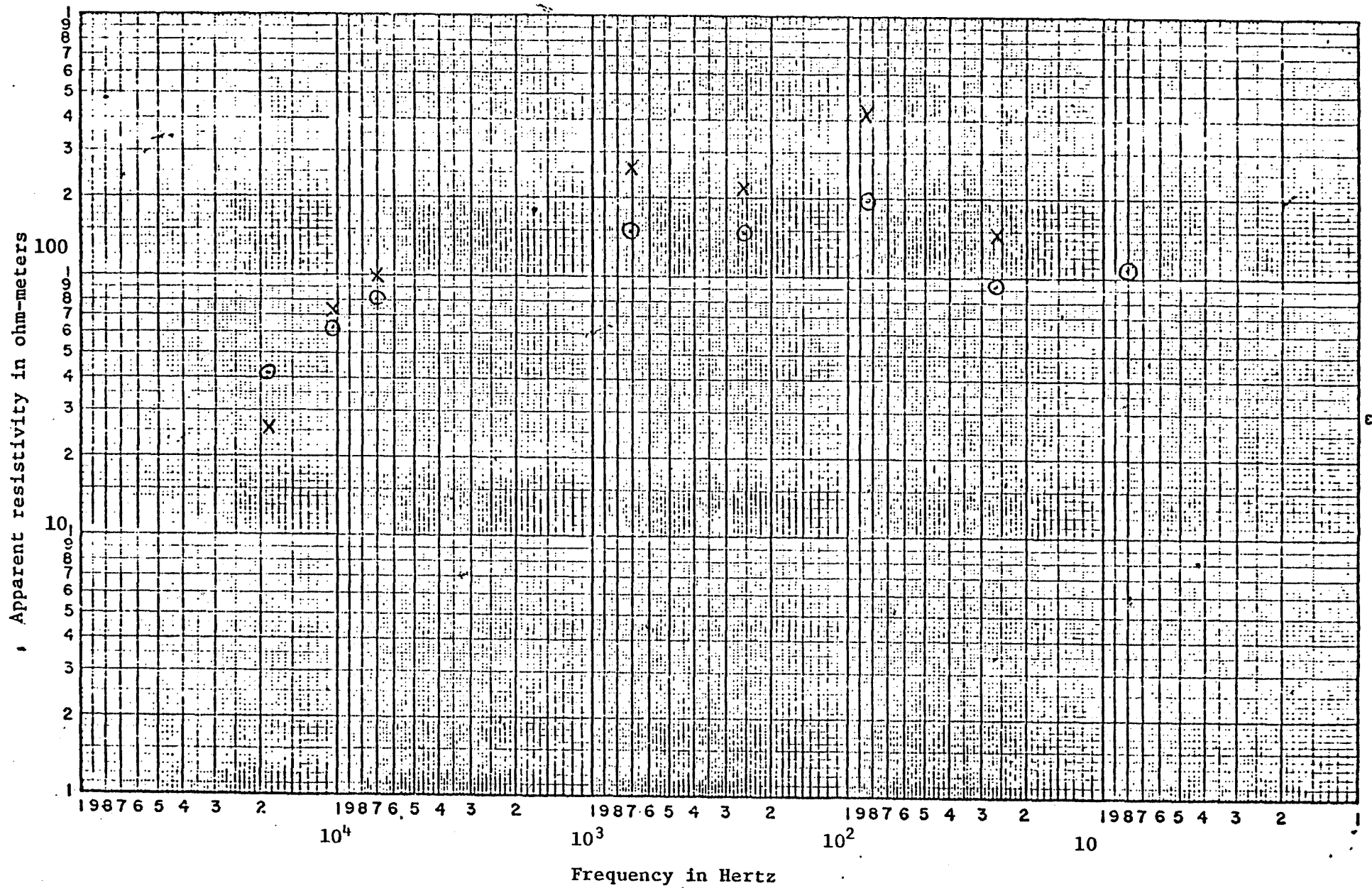

Figure 11. AMT sounding, Long Valley #16. x, electric line west, ⊙, electric line north.



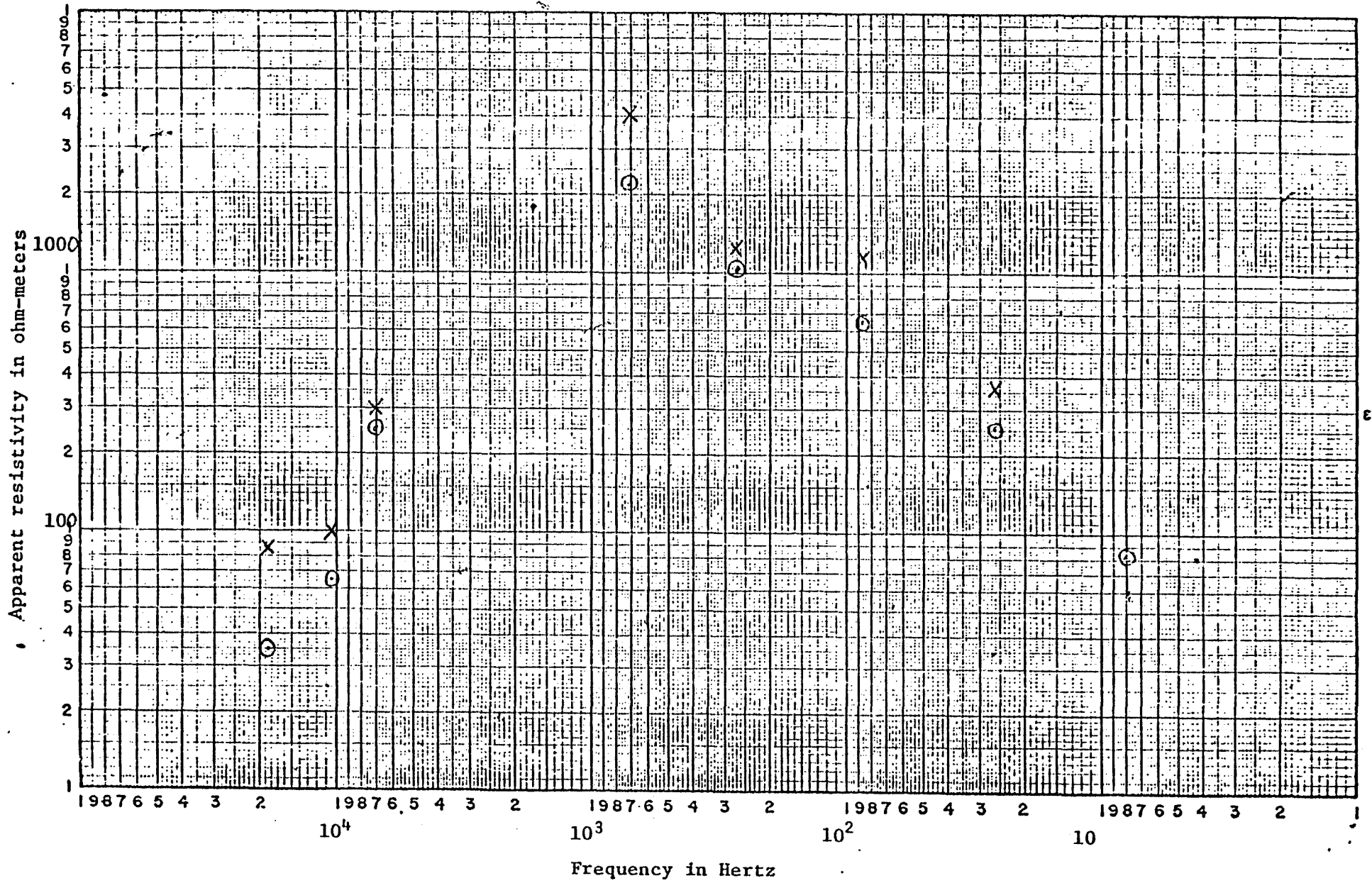

Figure 13. AMT sounding, Long Valley #18. x, electric line east, O electric line north.

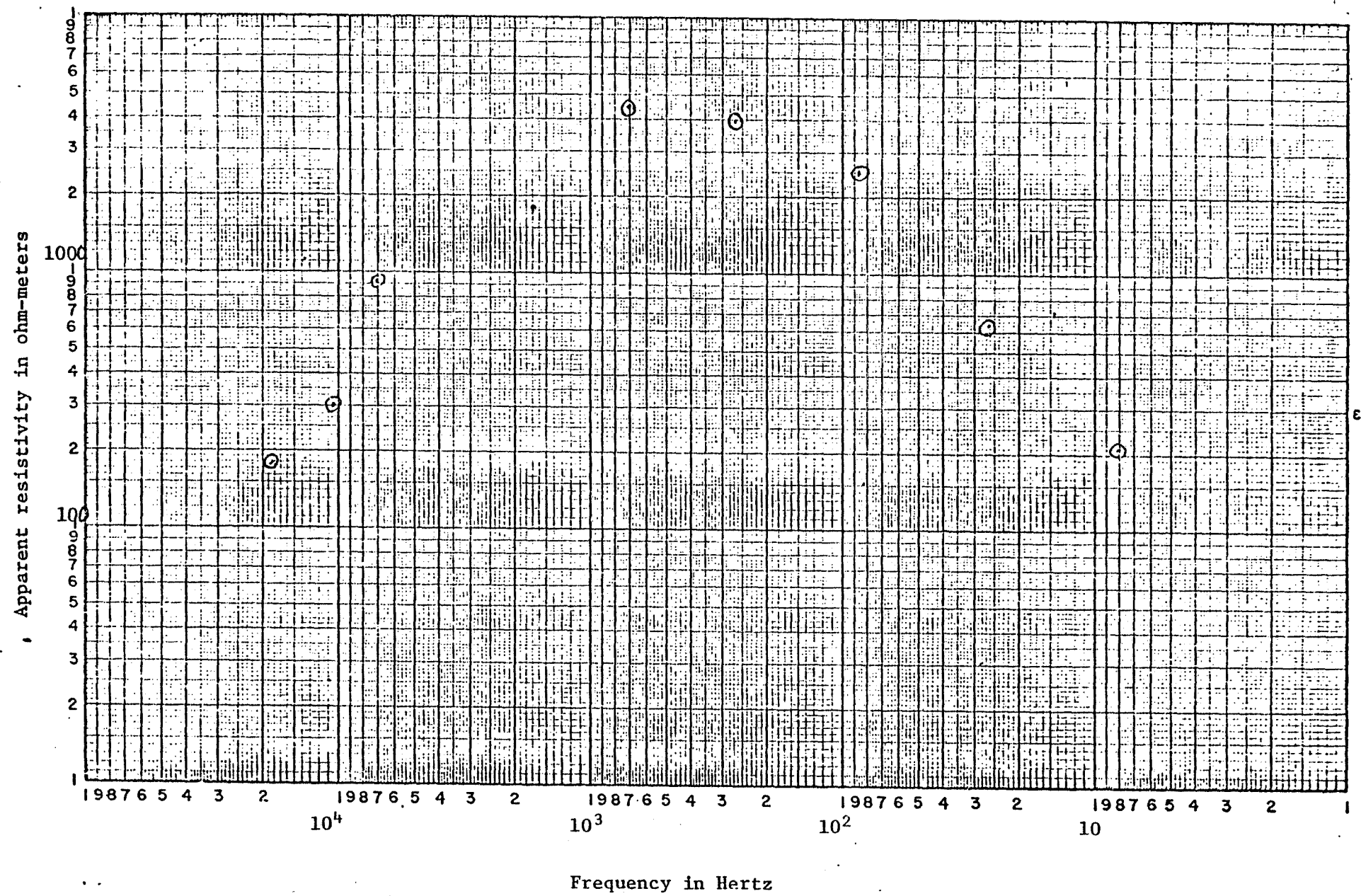

Figure 14. AMT sounding, Long Valley #19. ⊗ electric line north.

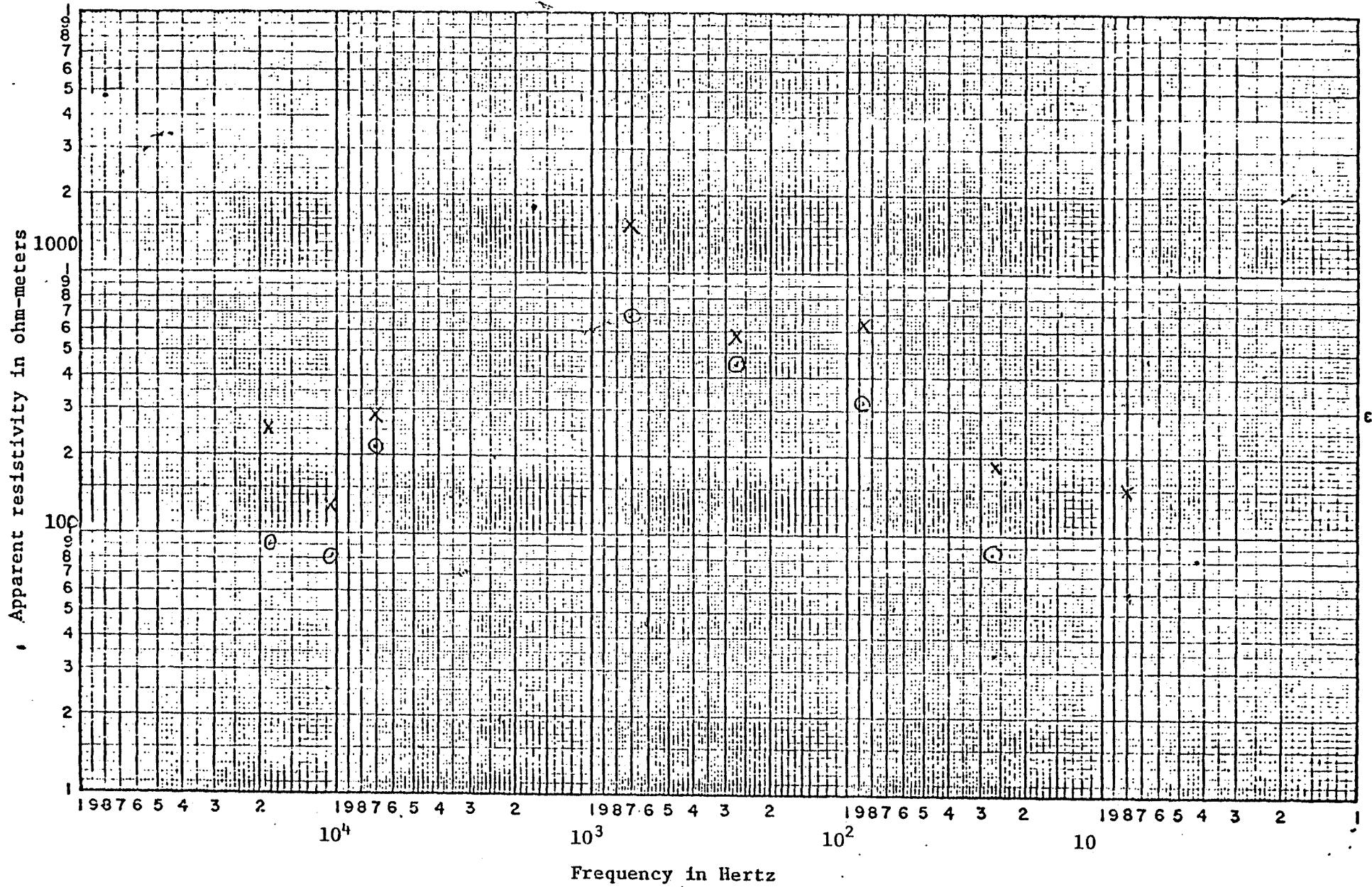

Figure 15. AMT sounding, Long Valley #20. x, electric line east, O, electric line south.

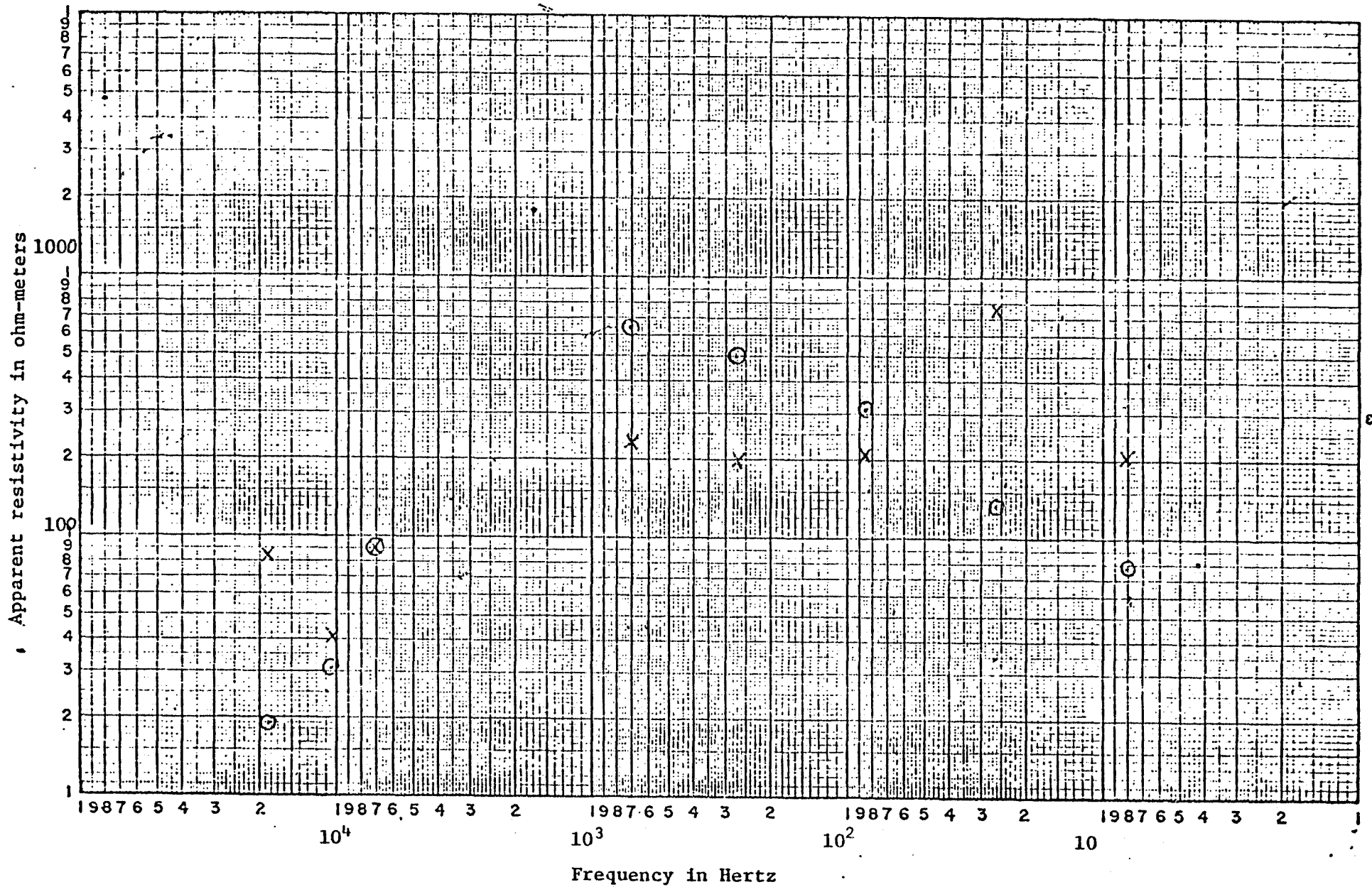

Figure 16. AMT sounding, Long Valley #21. x, electric line west, ⊗ electric line north.

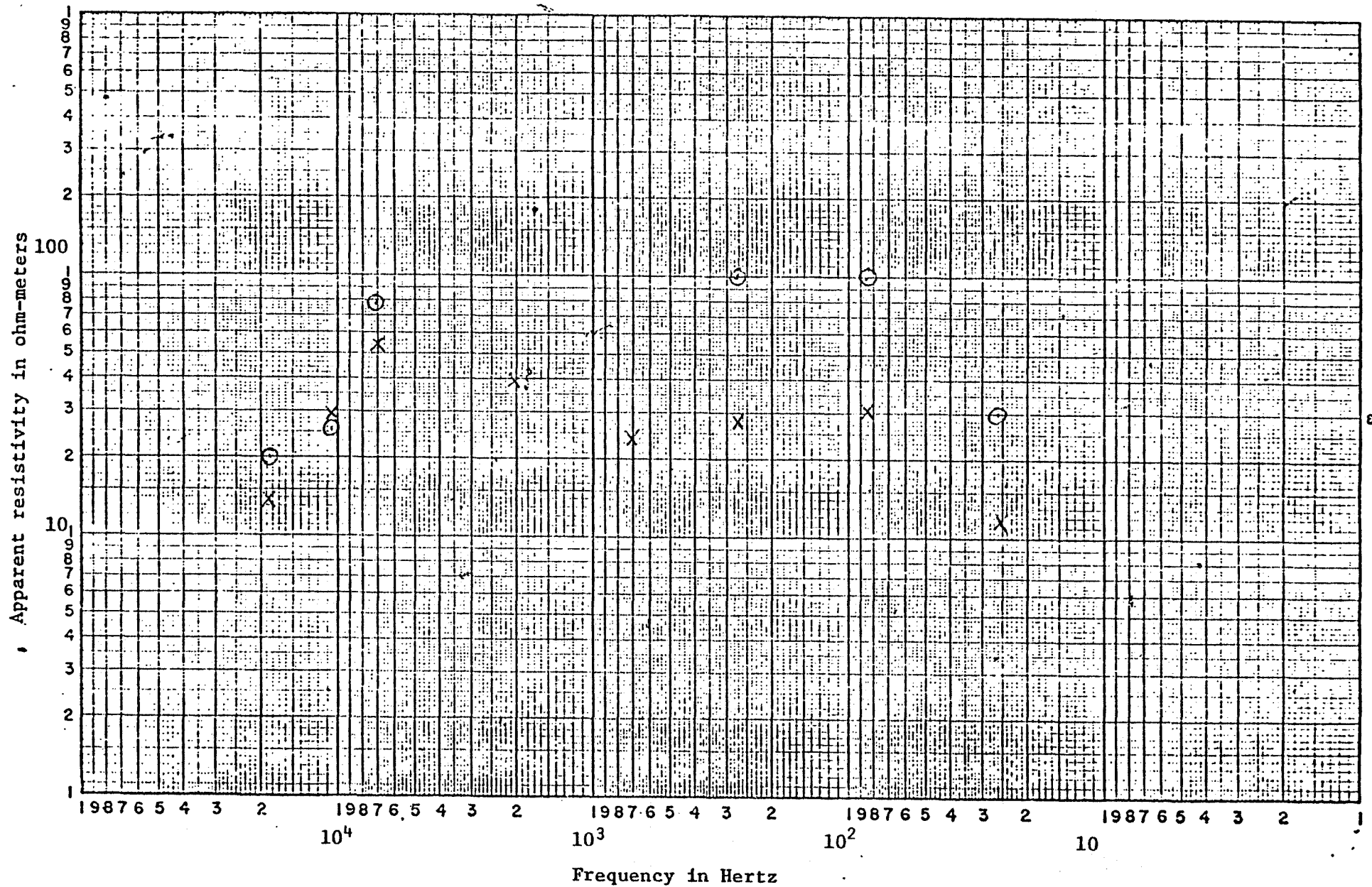

Figure 17. AMT sounding, Long Valley #22. x, electric line west, O electric line south.

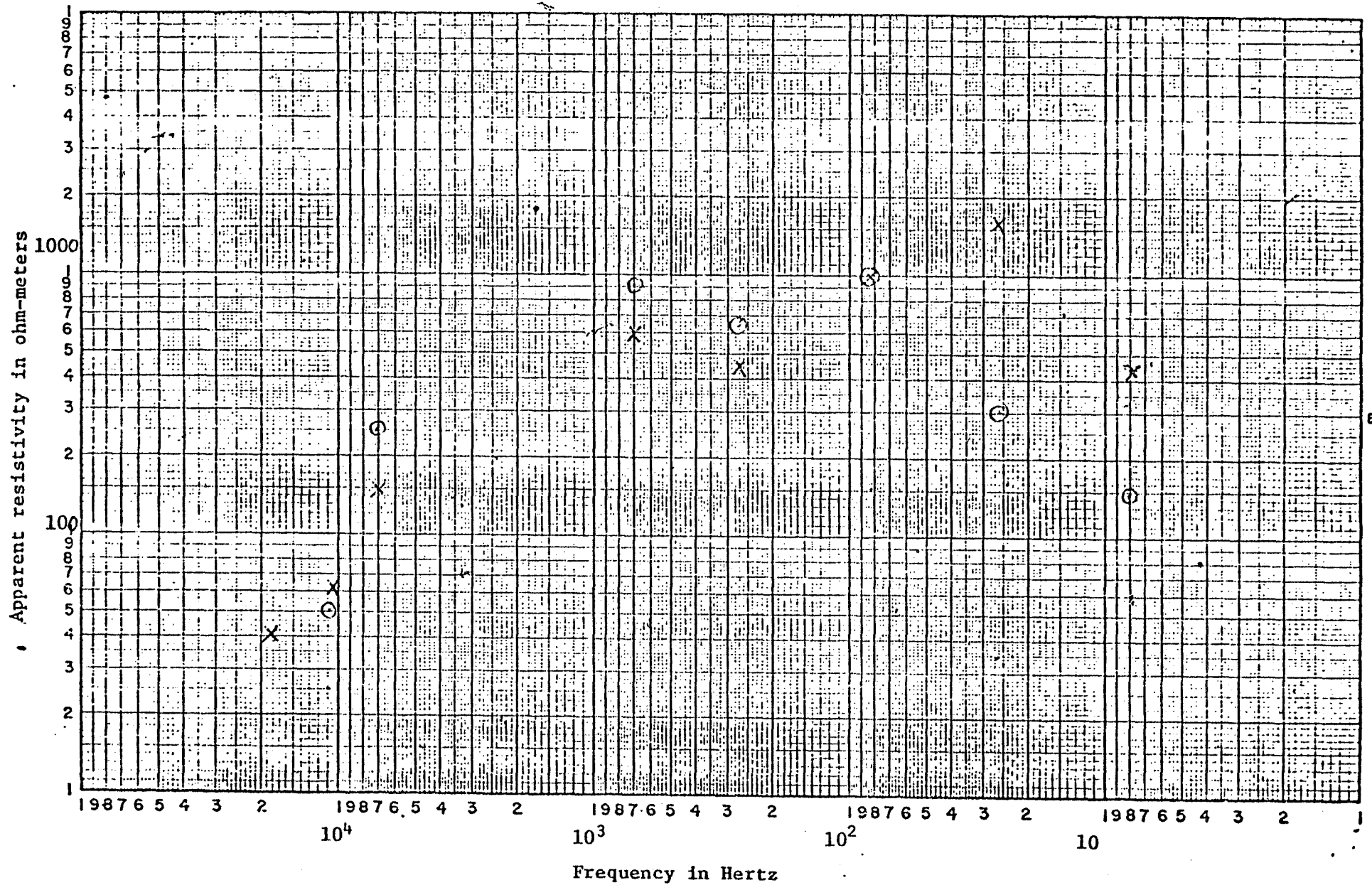
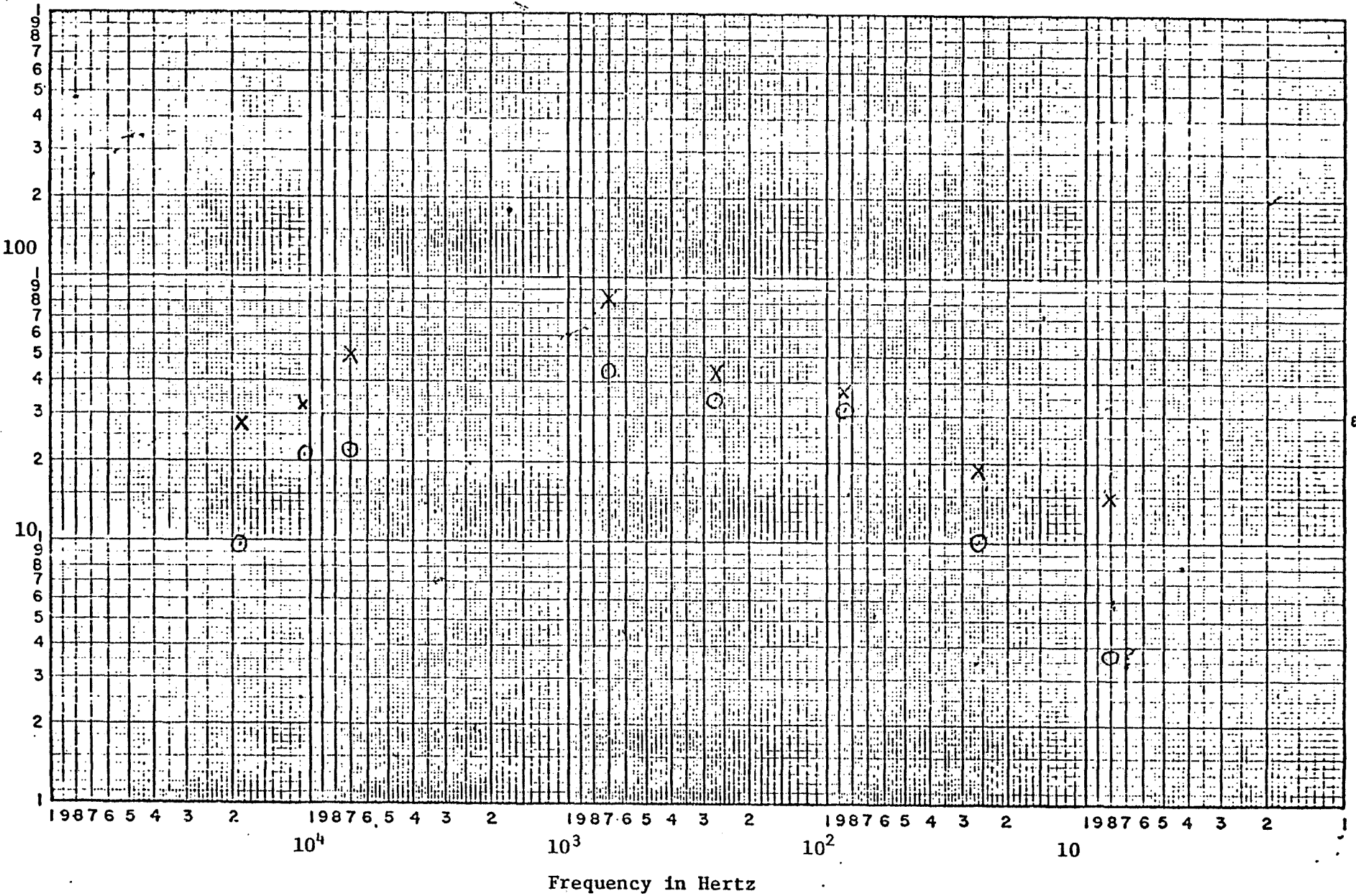

Figure 18 -- AMT sounding, Long Valley #23. x, electric line east, O electric line south.

03
Apparent resistivity in ohm-meters



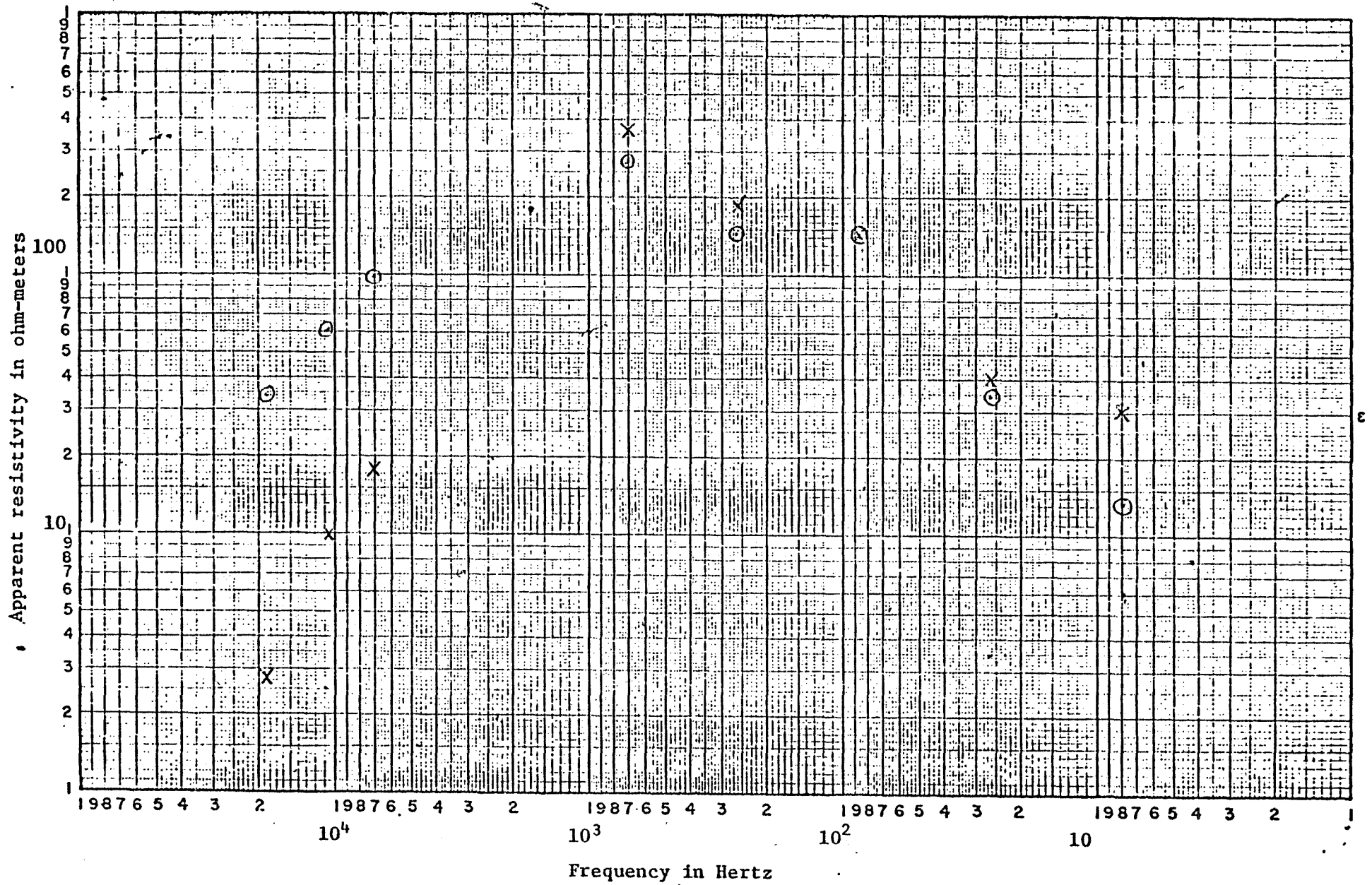

Figure 20. AMT sounding, Long Valley #25. x, electric line east, O electric line north.

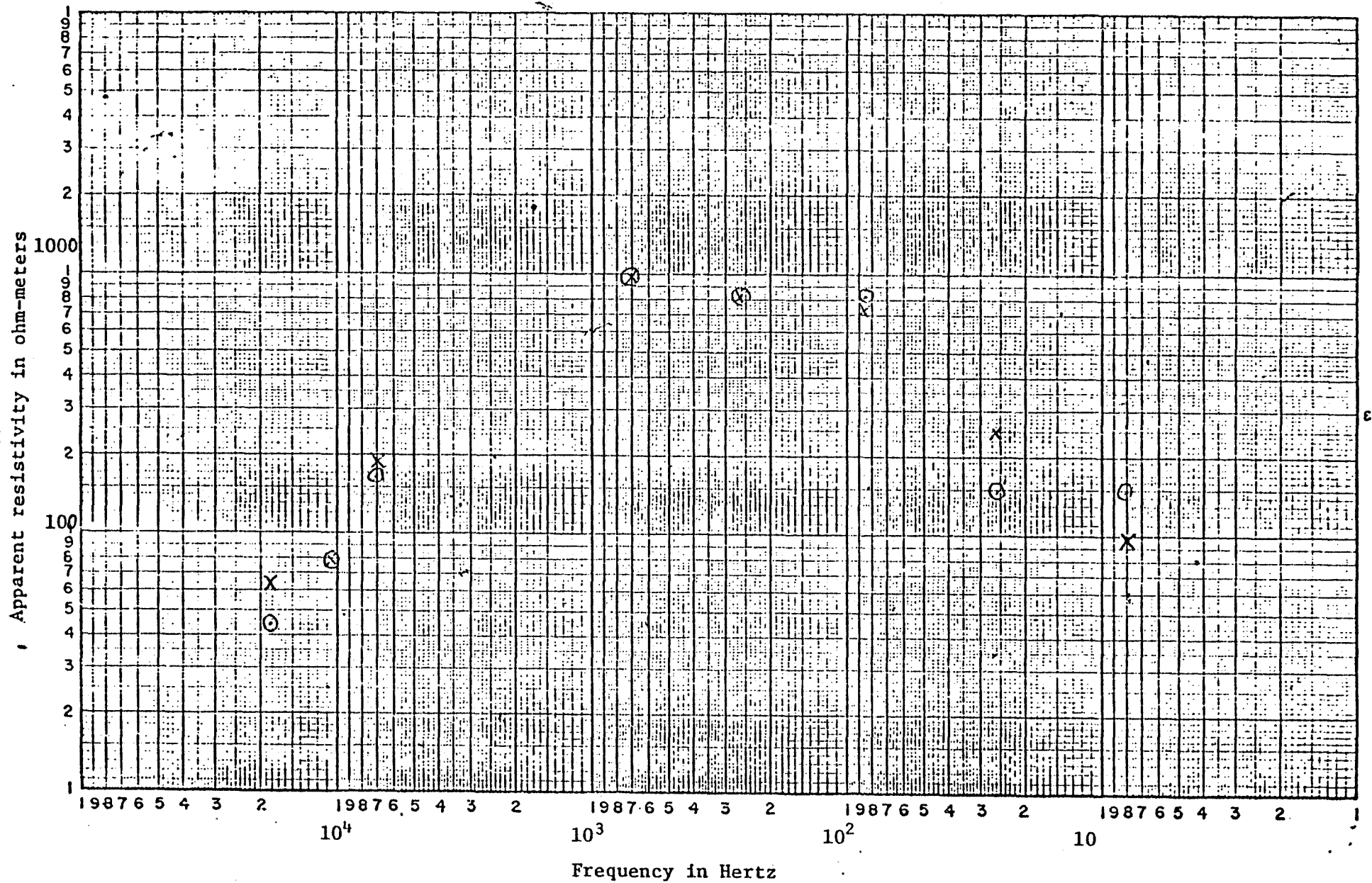

Figure 21. AMT sounding, Long Valley #26. x, electric line west, O electric line north.

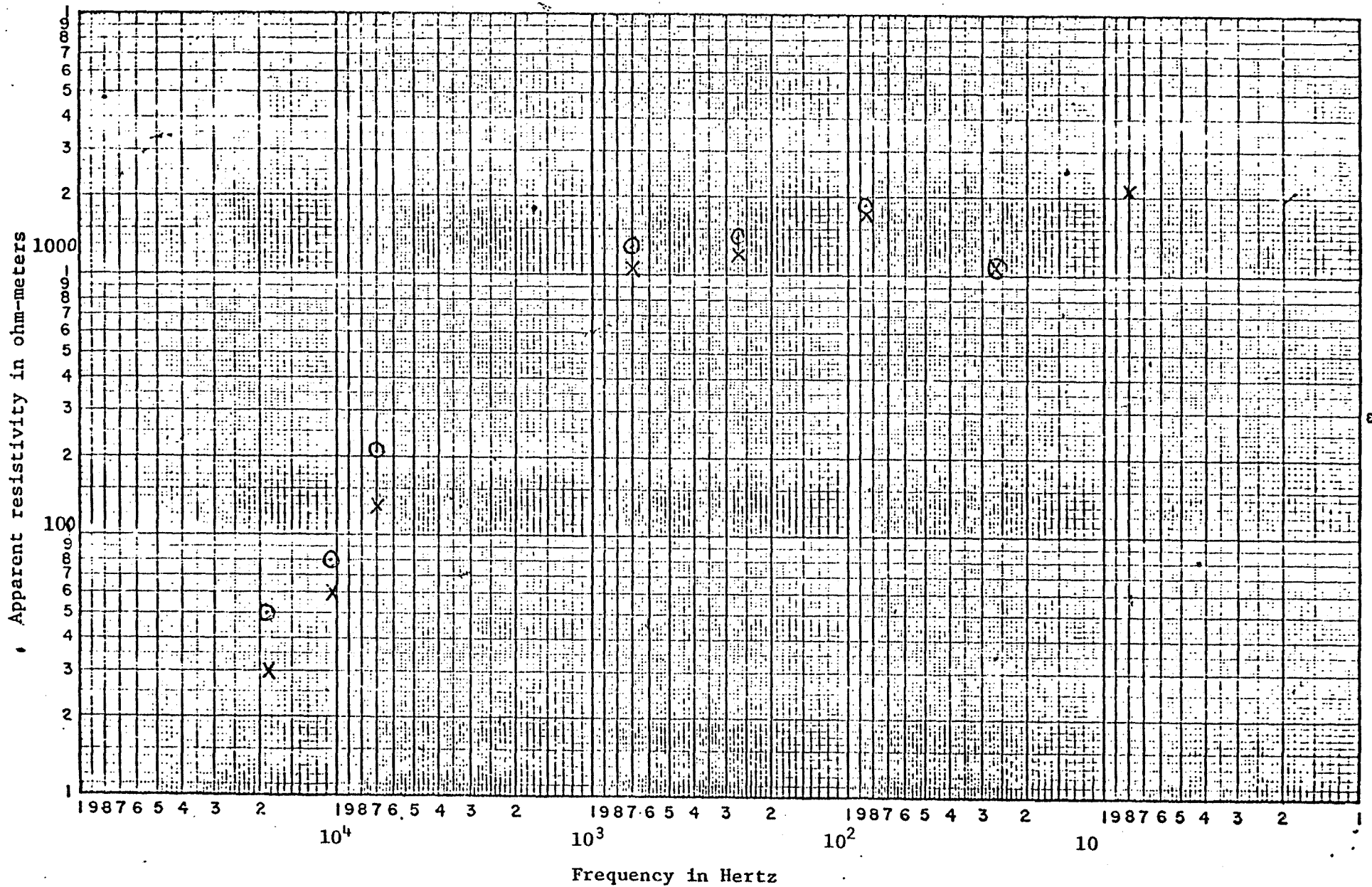

Figure 22. AMT sounding, Long Valley #27, x, electric line west, O electric line south.

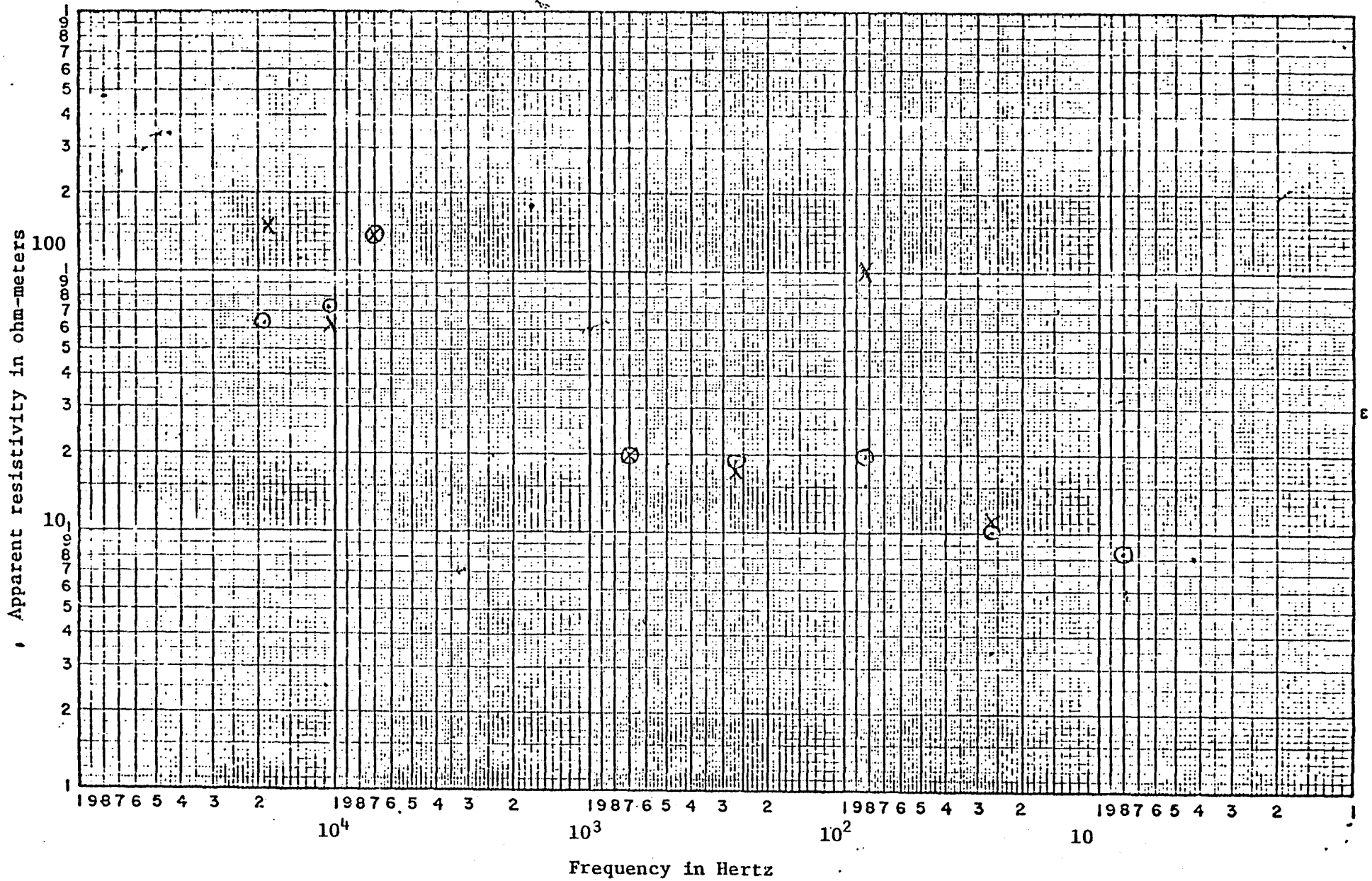

Figure 23. AMT sounding, Long Valley #28. x, electric line west, O electric line north.

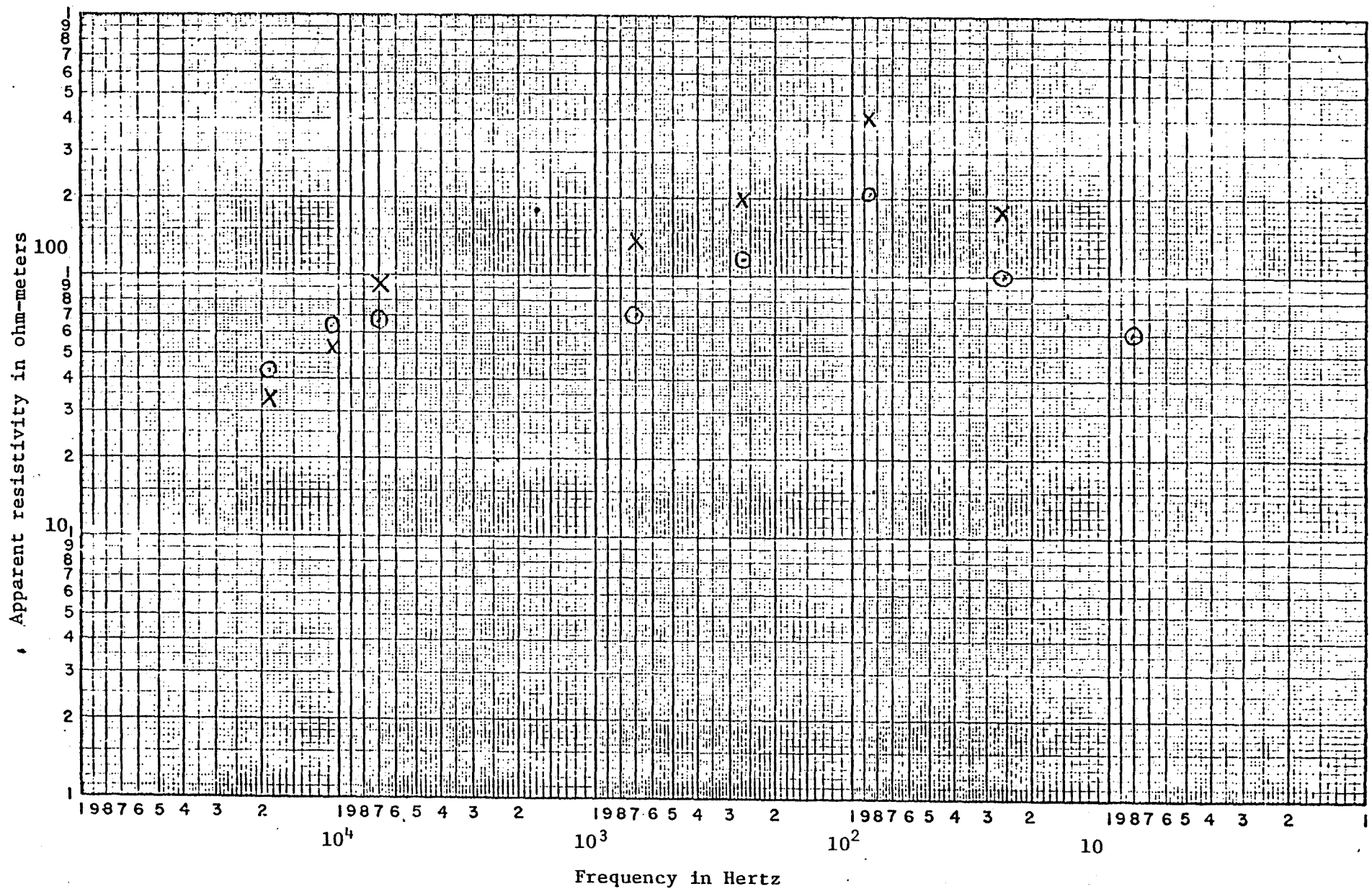

Figure 24. AMT sounding, Long Valley #29. x, electric line west, O electric line south.

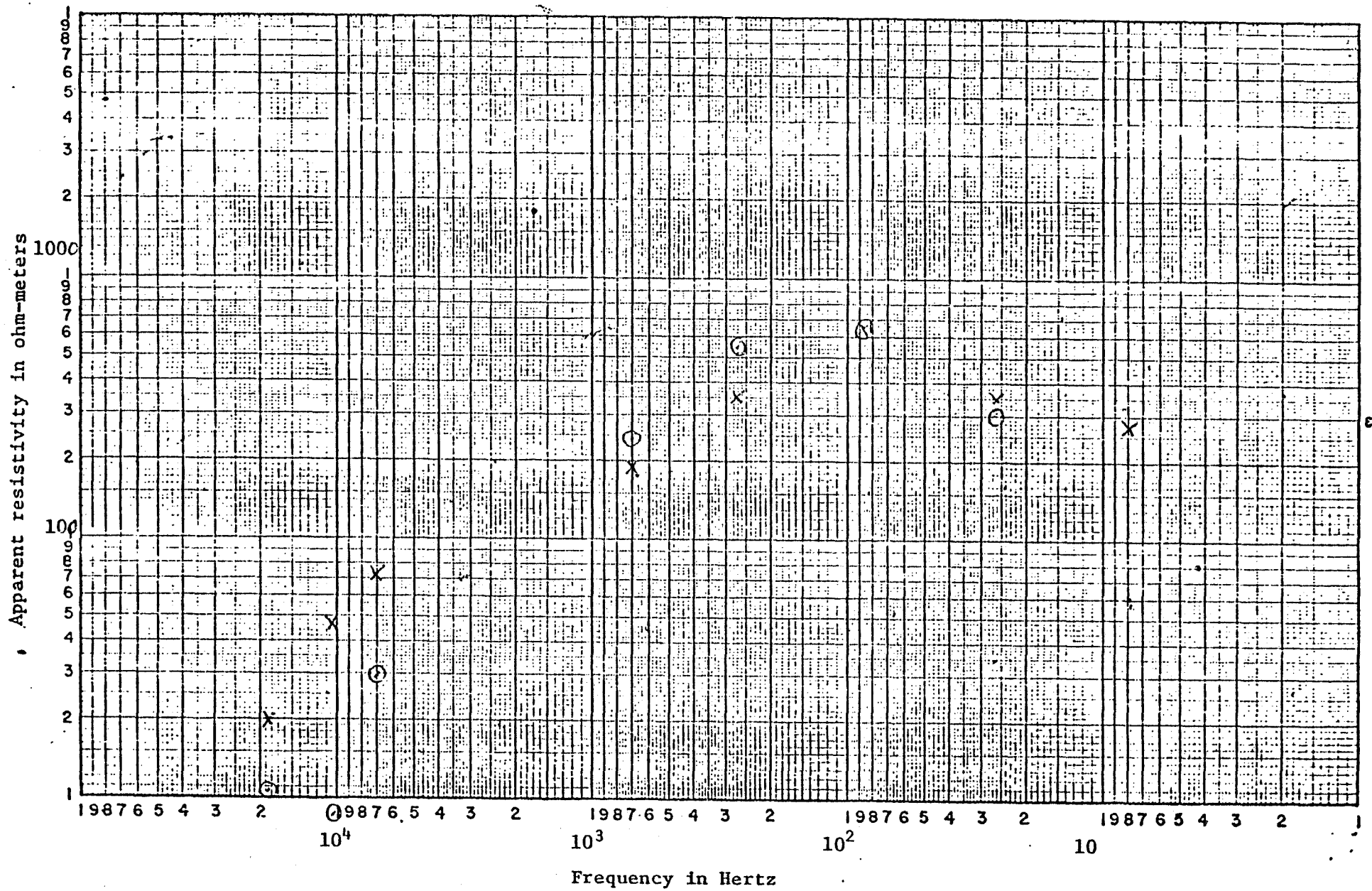

Figure 25. AMT sounding, Long Valley #30. x, electric line east, O, electric line south.

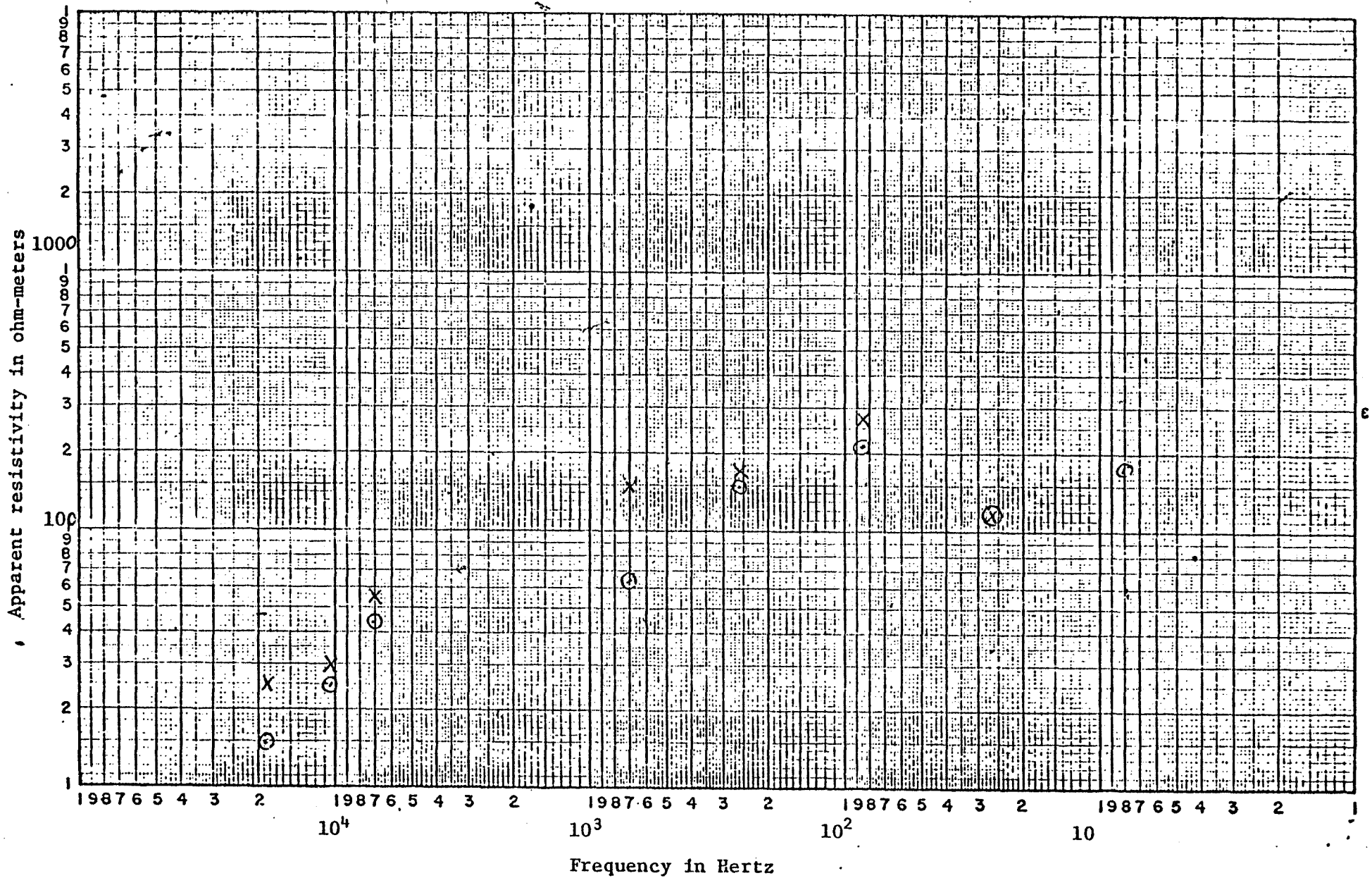
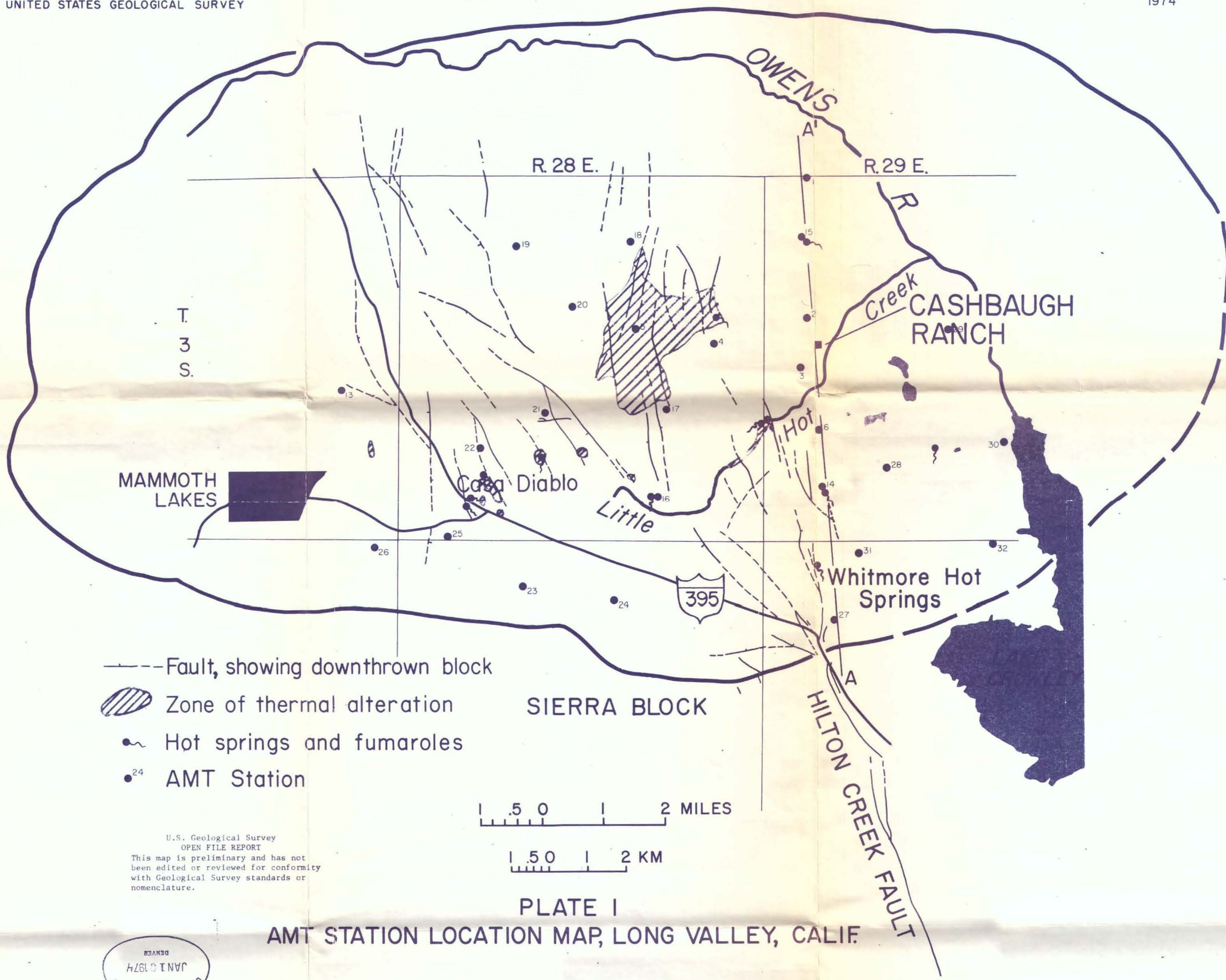

Figure 27. AMT sounding, Long Valley #32. x, electric line east, O electric line south.



- Fault, showing downthrown block
- ▨ Zone of thermal alteration
- ~ Hot springs and fumaroles
- ²⁴ AMT Station

U.S. Geological Survey
OPEN FILE REPORT
This map is preliminary and has not
been edited or reviewed for conformity
with Geological Survey standards or
nomenclature.

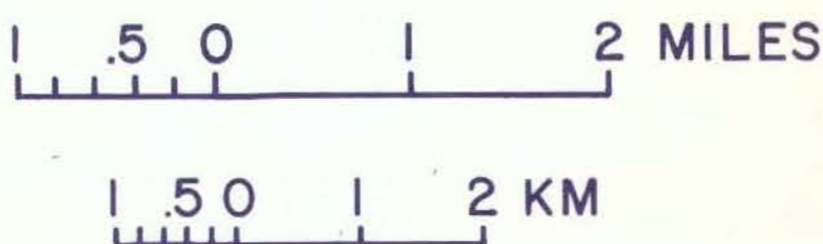

PLATE I
AMT STATION LOCATION MAP, LONG VALLEY, CALIF

U.S. GEOLOGICAL SURVEY
LIBRARY
DENVER
JAN 13 1974

PLEASE REPLACE IN POCKET
IN BACK OF BOUND VOLUME

(200)
R298
no. 1920

Amex Exploration, Inc.
Geothermal Library

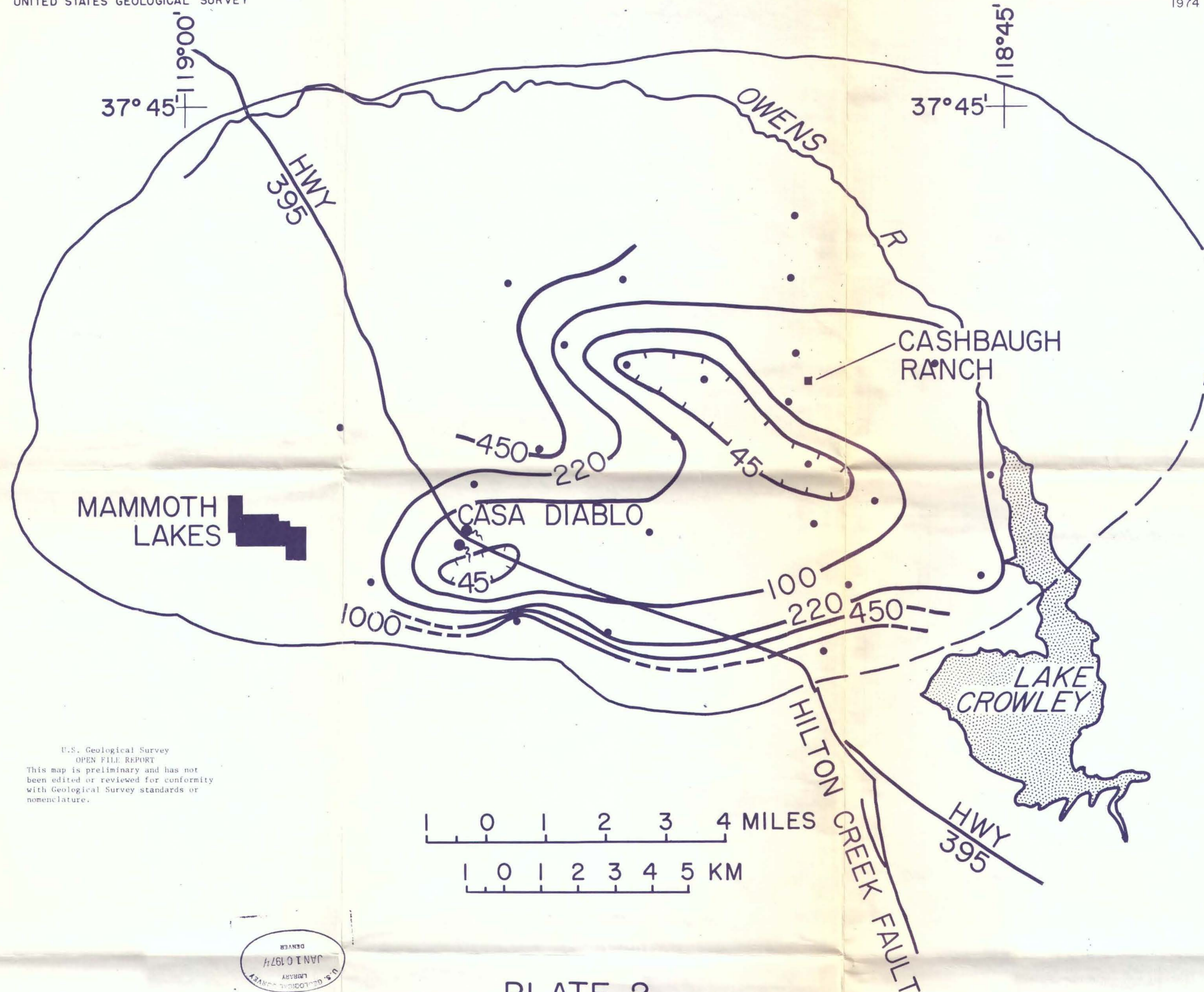

U.S. Geological Survey
OPEN FILE REPORT
This map is preliminary and has not
been edited or reviewed for conformity
with Geological Survey standards or
nomenclature.

JAN 1 1974
U.S. GEOLOGICAL SURVEY
DENVER

PLATE 2

26-Hz APPARENT RESISTIVITY MAP, LONG VALLEY, CALIF. (ELECTRIC LINE E-W)
VALUES IN OHM-METERS.

Amex Exploration, Inc.
Geothermal Library

PLEASE REPLACE IN POCKET
IN BACK OF BOUND VOLUME
R 295
JAN 15 1974

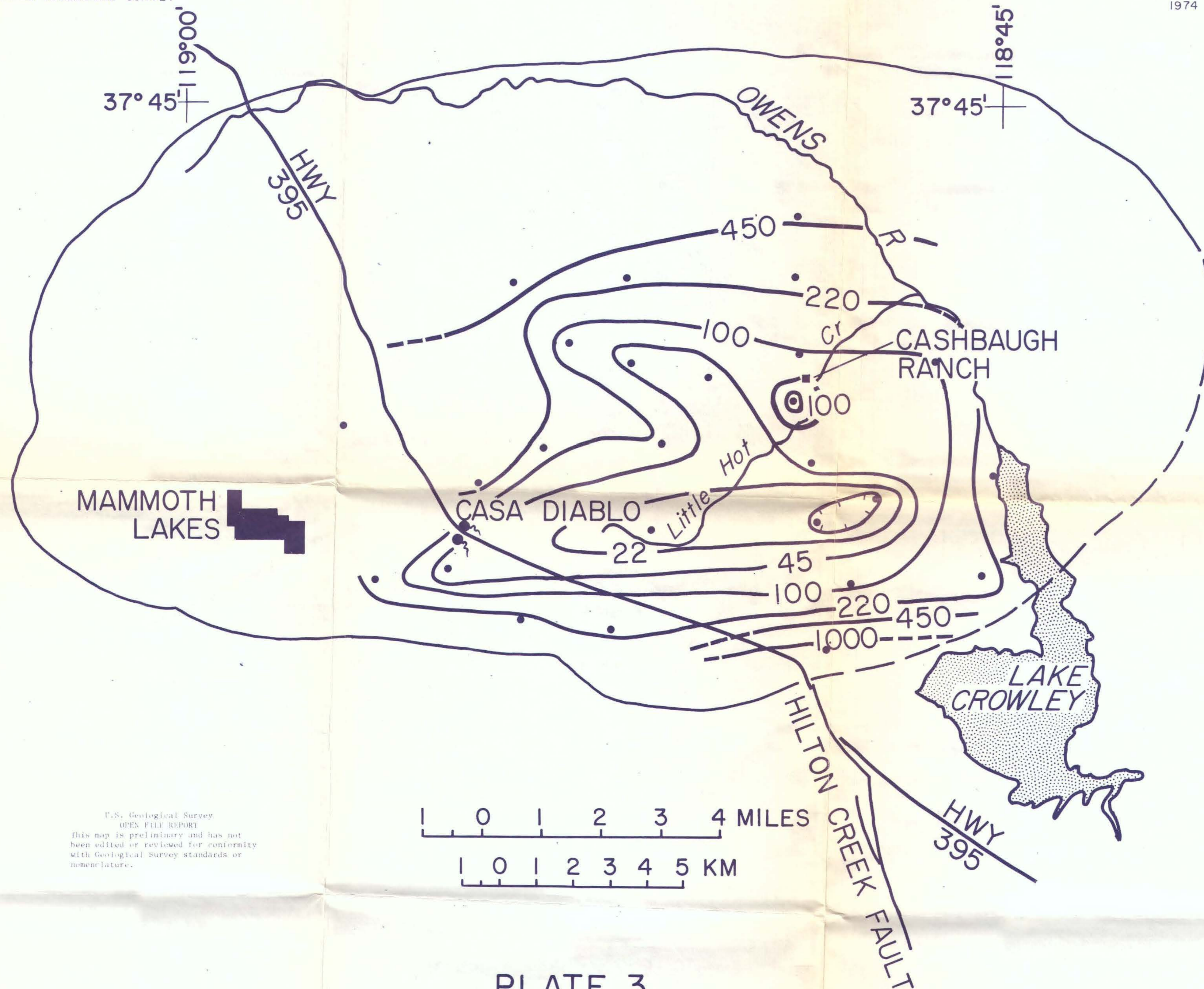

U.S. Geological Survey
OPEN FILE REPORT
This map is preliminary and has not
been edited or reviewed for conformity
with Geological Survey standards or
nomenclature.

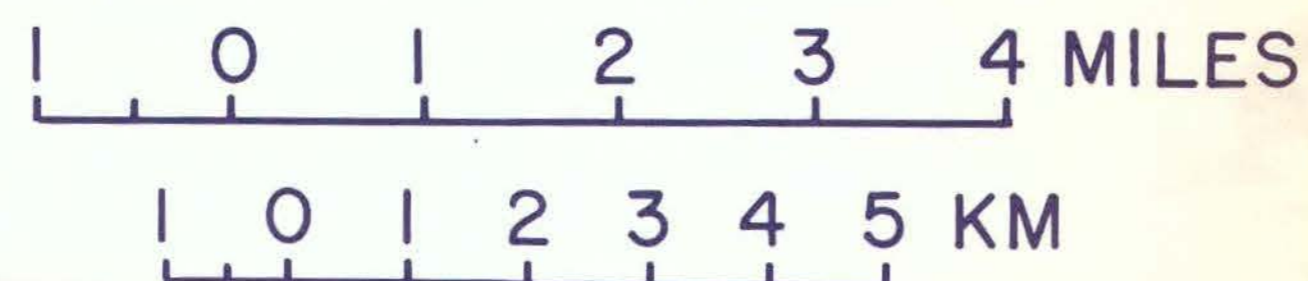

PLATE 3
26-Hz APPARENT RESISTIVITY MAP, LONG VALLEY, CALIF. (ELECTRIC LINE N-S)
VALUES IN OHM-METERS.

PLEASE REPLACE IN POKET!
IN BACK OF BOUND VOLUME

RECEIVED
JAN 10 1974
U.S. GEOLOGICAL SURVEY

Amex Exploration, Inc.
Geothermal Library

(200)
R490
no. 1930

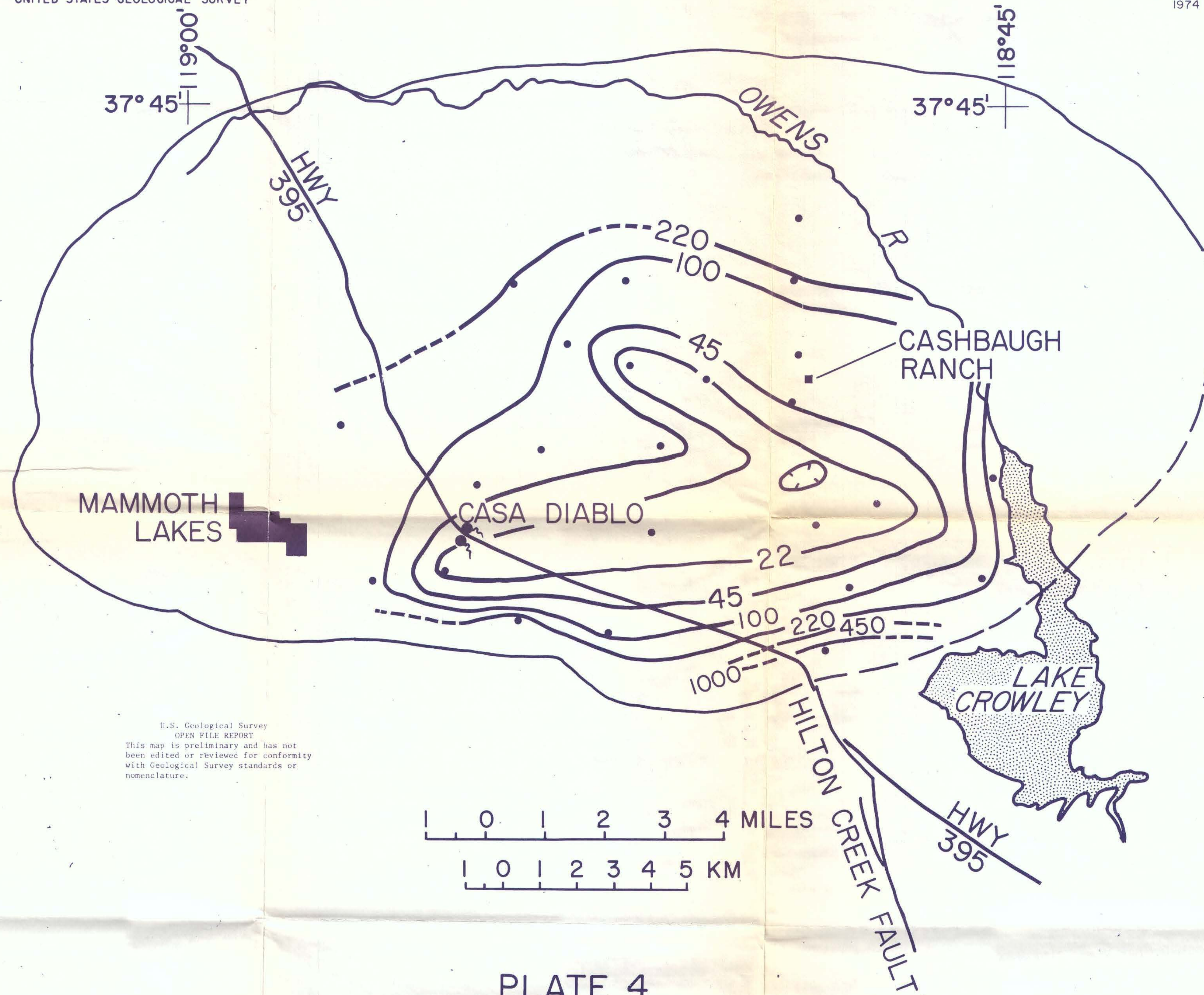

U.S. Geological Survey
OPEN FILE REPORT
This map is preliminary and has not
been edited or reviewed for conformity
with Geological Survey standards or
nomenclature.

PLATE 4
8-Hz APPARENT RESISTIVITY MAP, LONG VALLEY, CALIF.
VALUES IN OHM-METERS

Amex Exploration, Inc.
Geothermal Library

PLEASE REFERENCE IN POCKET
IN BACK OF BOUND VOLUME
JAN 10 1974
R 298
no. 1920
DENVER
(200)

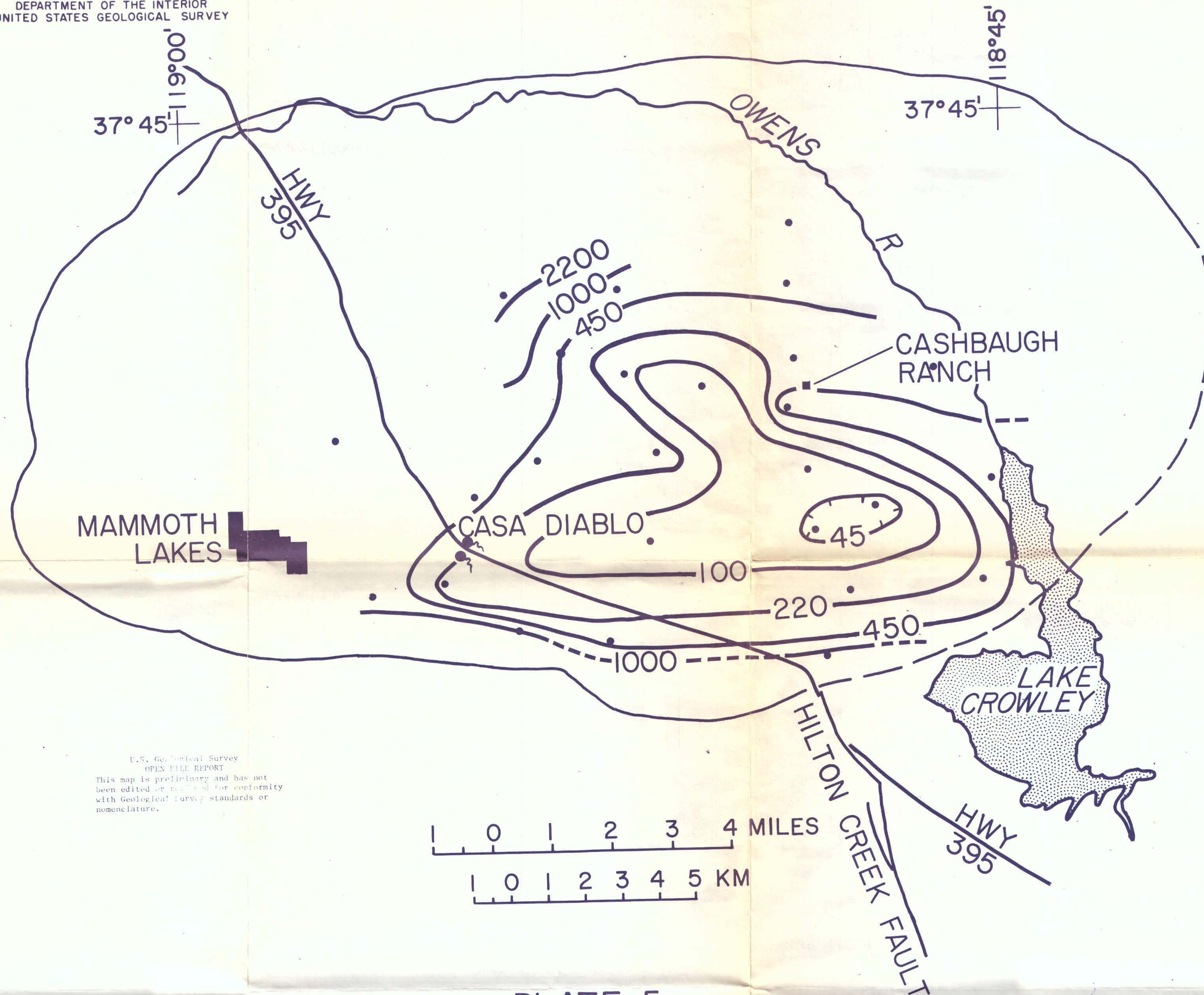

U.S. Geological Survey
OPEN FILE REPORT
This map is preliminary and has not
been edited or revised for conformity
with Geological Survey standards or
nomenclature.

PLATE 5
86-Hz APPARENT RESISTIVITY MAP, LONG VALLEY, CALIF.
VALUES IN OHM-METERS

JAN 10 1974
LIBRARY
U.S. GEOLOGICAL SURVEY
DENVER

PLEASE REPLACE IN POCKET
IN BACK OF BOUND VOLUME

Amex Exploration, Inc.
Geothermal Library

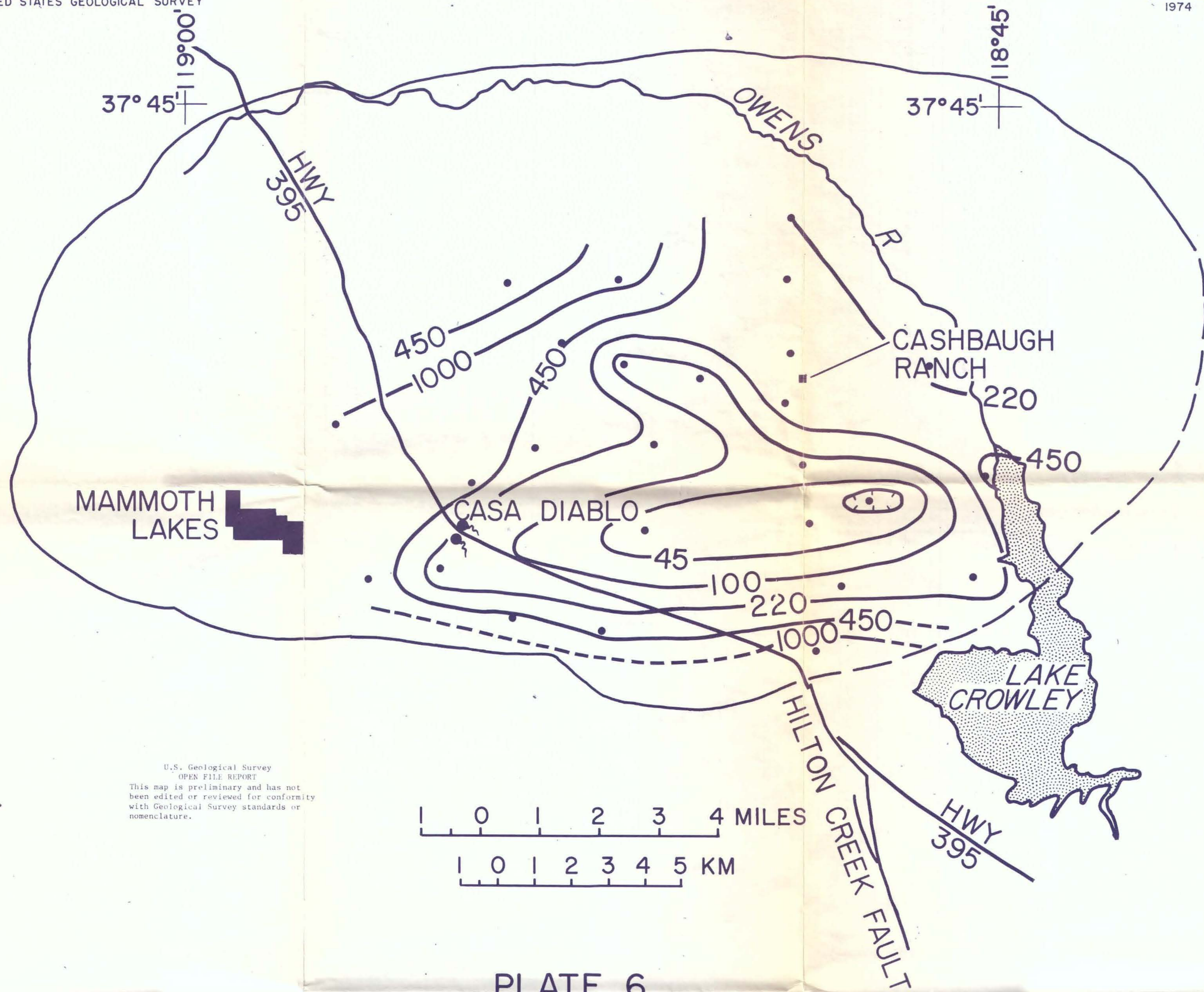

U.S. Geological Survey
OPEN FILE REPORT
This map is preliminary and has not
been edited or reviewed for conformity
with Geological Survey standards or
nomenclature.

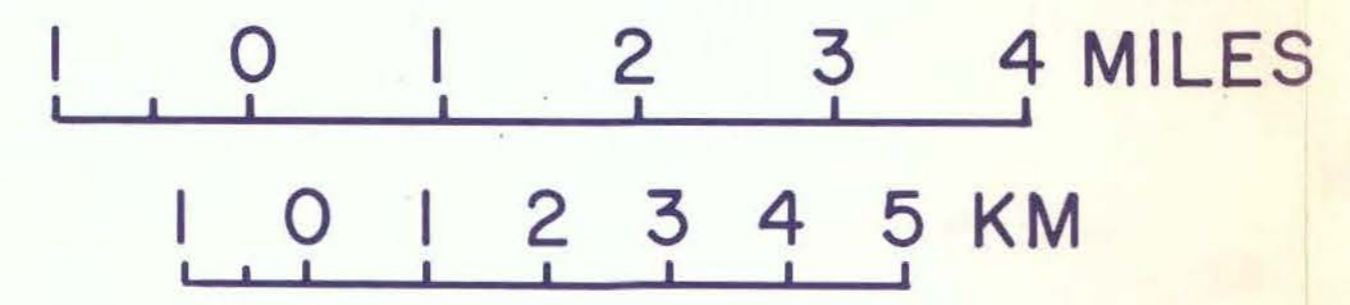

PLATE 6
270-Hz APPARENT RESISTIVITY MAP, LONG VALLEY, CALIF.
VALUES IN OHM-METERS

Amex Exploration, Inc.
Geothermal Library

PLEASE REPLACE IN POCKET
IN BACK OF BOUND VOLUME
U.S. GEOLOGICAL SURVEY
LIBRARY
JAN 10 1974
DENVER
R 992
no. 1920
(200)

(200)
R290
no. 1920

OPEN FILE
1974

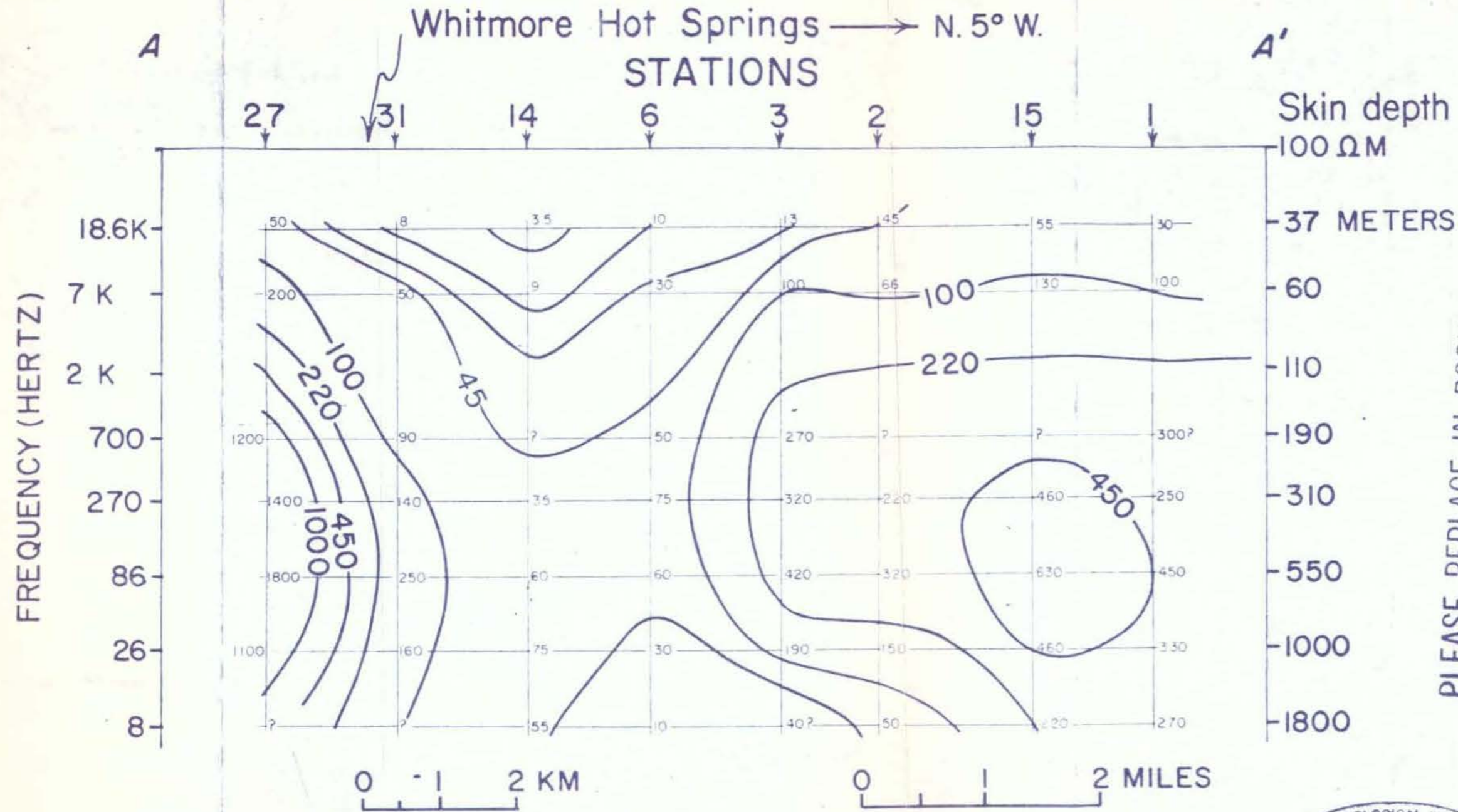

PLEASE REPLACE IN POCKET
IN BACK OF BOUND VOLUME

AMT PSEUDOSECTION ALONG A-A' (ELECTRIC LINE E-W)
LONG VALLEY, CALIF.
PLATE 8

U.S. Geological Survey
OPEN FILE REPORT
This illustration is preliminary and has not
been edited or reviewed for conformity with
Geological Survey standards or nomenclature.

Amax Exploration, Inc.
Geothermal Library



(200)
R290
no. 1920

DEPARTMENT OF THE INTERIOR
UNITED STATES GEOLOGICAL SURVEY

OPEN FILE
1974



Whitmore Hot Springs → N. 5° W. STATIONS

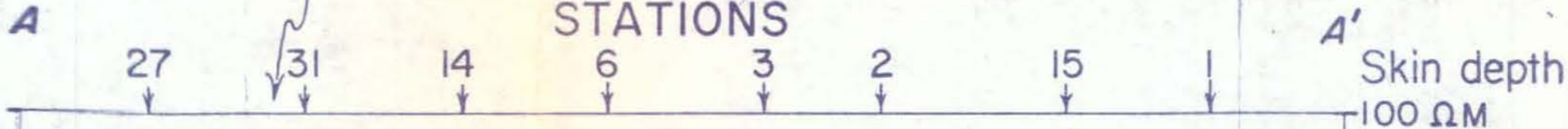

PLEASE REPLACE IN POCKET
IN BACK OF BOUND VOLUME

FREQUENCY (HERTZ)

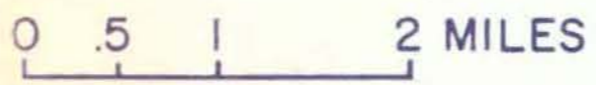
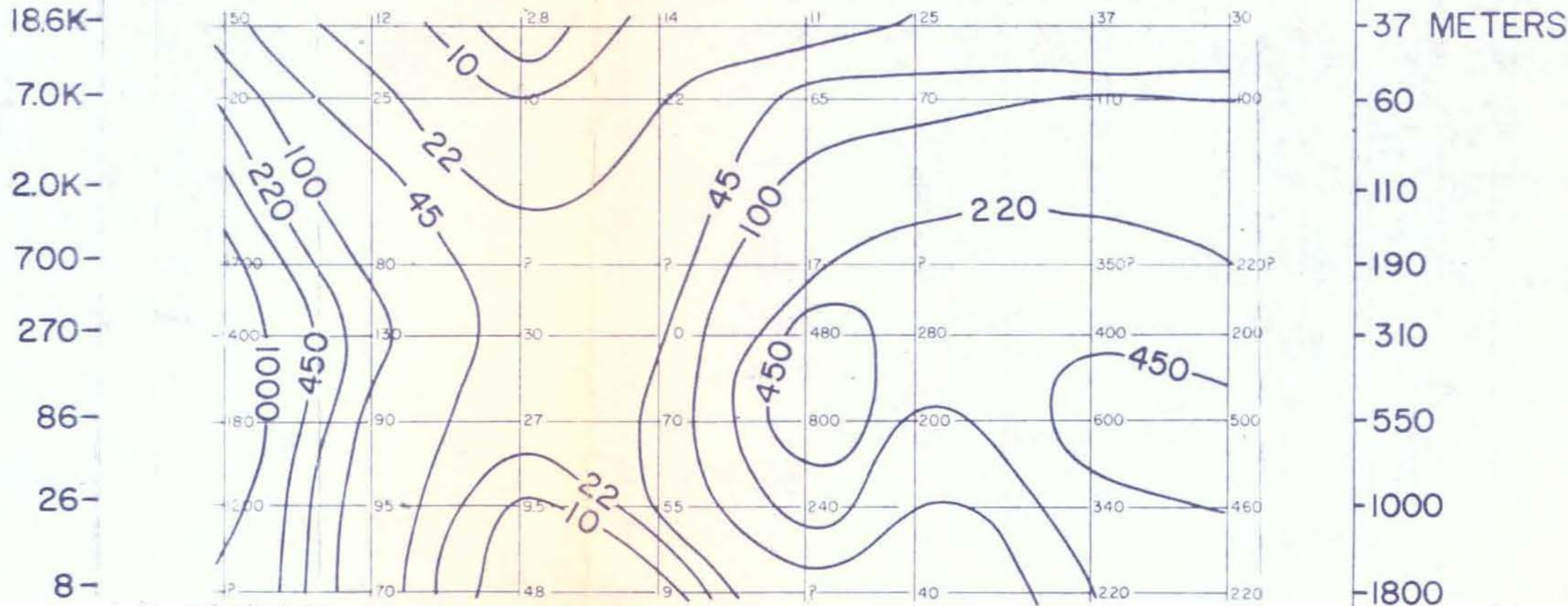

This illustration is preliminary and has not been edited or reviewed for conformity with Geological Survey standards or nomenclature.

AMT PSEUDOSECTION ALONG A-A' (ELECTRIC LINE N-S) LONG VALLEY, CALIF. PLATE 9

Amax Exploration, Inc.
Geothermal Library

1001
295
2.1920

DEPARTMENT OF THE INTERIOR
UNITED STATES GEOLOGICAL SURVEY

OPEN FILE
1974

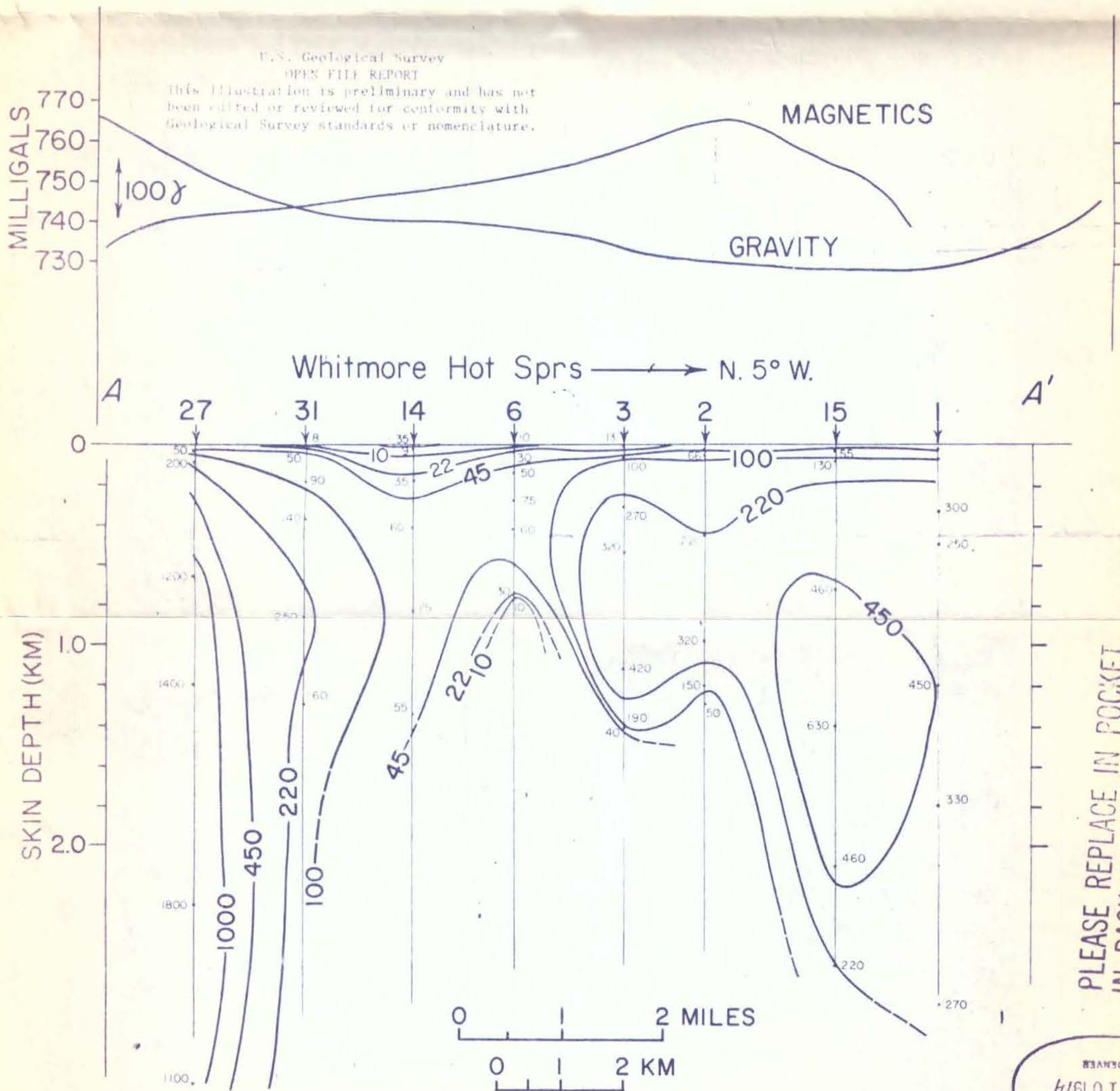

SKIN-DEPTH PSEUDOSECTION ALONG A-A' (ELECTRIC LINE E-W)
LONG VALLEY, CALIF.

PLATE 10

PLEASE REPLACE IN POCKET
IN BACK OF BOUND VOLUME

Amex Exploration, Inc.
Geothermal Library



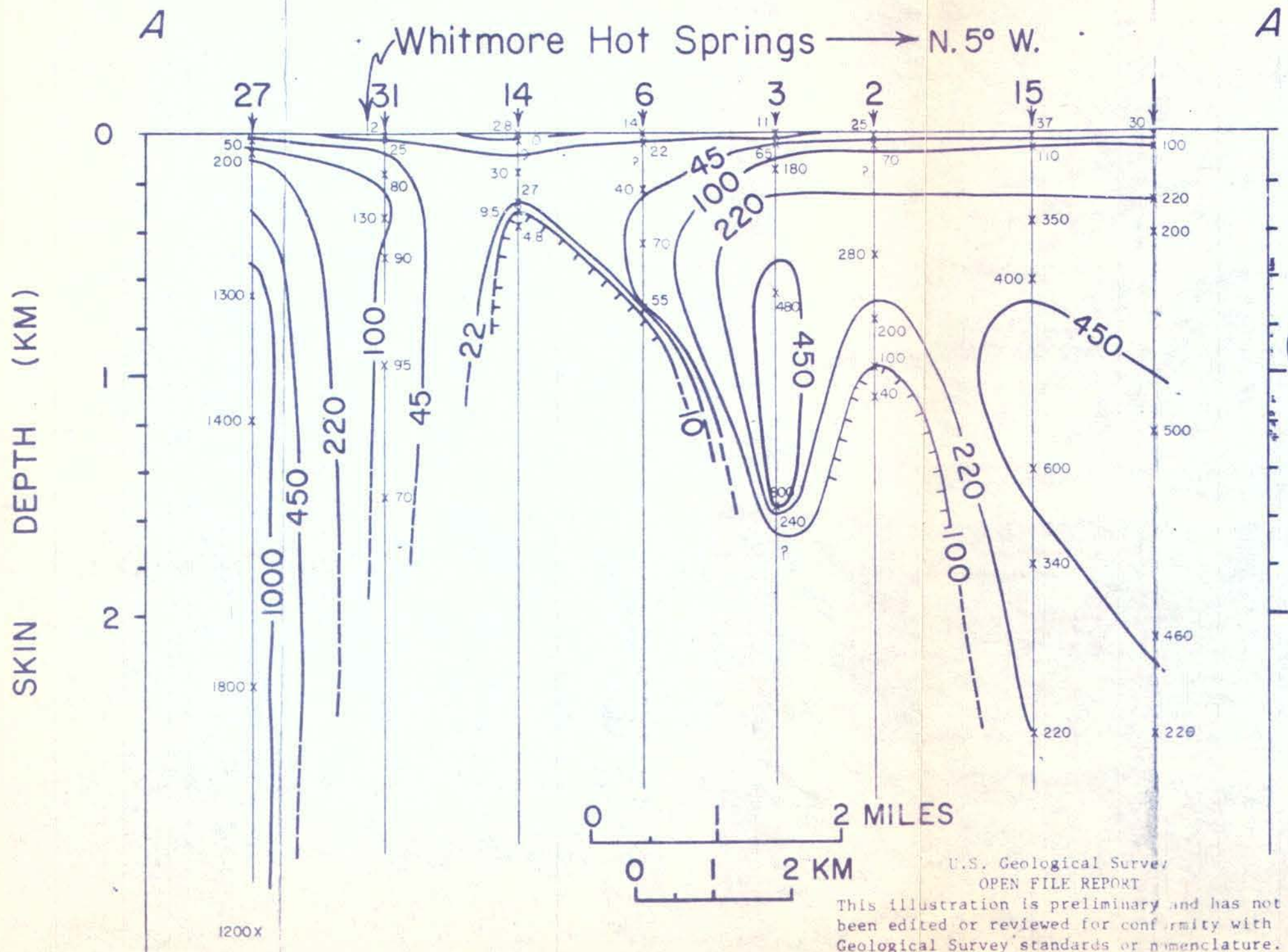

SKIN-DEPTH PSEUDOSECTION ALONG A-A' (ELECTRIC LINE N-S)
LONG VALLEY, CALIF.
PLATE II



PLEASE REPLACE IN POCKET
IN BACK OF BOUND VOLUME

(200)
Page
no. 1920