



December 19, 1985

TO: R. G. Daniel  
A. Schriener Jr.

FM: G. A. Nordquist *G.A. Nordquist*

RE: UPDATED GEOPHYSICAL INTERPRETATION OF THE MEDICINE LAKE VOLCANO

<u>Table of Contents</u>	<u>Page</u>
1. <u>Summary and Conclusions</u>	2
2. <u>Recommendations</u>	2
3. <u>Introduction</u>	2
4. <u>Geologic and Structural Setting</u>	3
5. <u>Exploration Model</u>	3
6. <u>Geophysics Review</u>	4
7. <u>Gravity</u>	4
8. <u>TDEM</u>	5
9. <u>MT</u>	6
10. <u>Geoelectric Cross-Sections</u>	6
11. <u>Summary of Gravity and EM Results</u>	7
12. <u>References</u>	9
13. <u>List of Figures</u>	11
14. <u>List of Plates</u>	12
15. <u>Appendix I</u>	13

## 1. Summary and Conclusions

A shallow low-resistivity zone is centered over an upwarp of the resistive and dense basement beneath the Medicine Lake Volcano (MLV). A synthesis of MT and gravity models indicates that the shallow basement trends northeast and has vertical offsets which range from 1000 feet to as large as 5000 feet (Figure 8). These offsets may be the edges of intrusives and/or reflect faulting of the basement. A large intrusive or system of intrusives within the basement is postulated from gravity and is centered northeast of Medicine Lake (Figure 9). This body was drilled into by Well 17A-6 and is composed of intermediate to silicic rocks.

Areas of high fracture porosity and permeability may occur at the edges of the basement structures and around the postulated intrusive. Of specific interest are zones within a low-resistivity anomaly observed with the MT data at 1 Hz. Figure 9 shows three proposed locations for deep test wells. These locations are designed to test the hypothesis of high fracture porosities and permeabilities associated with the inferred basement structures.

A reconnaissance TDEM survey over an intrusive postulated from gravity (Nordquist, 1984) and located west of the Lava Beds National Monument showed no prospective targets for exploration.

## 2. Recommendations

- A. Future geophysical studies at Glass Mountain should be directed towards identifying subsurface fault trends and should include detailed TDEM surveys to resolve the shallow structures and a three-dimensional gravity interpretation for the basement structures. These results should be incorporated with geologic drilling and mapping information to formulate a structural model of the Medicine Lake Volcano.
- B. Lands located over the observed basement offsets and around the postulated intrusive body should be paid special consideration in a lease sale, especially those within the 1 Hz MT anomaly (Figure 9).
- C. Drill a deep production test in one of three locations proposed on Figure 9 to test the hypothesis of high fracture porosity and permeabilities associated with the postulated basement structures.

## 3. Introduction

Since early 1984, several hundred gravity sites and 49 TDEM sites have been obtained over the Medicine Lake Volcano (MLV). In addition, information from 46 Controlled Source Audio Magnetotelluric (CSAMT) sites and two MT sites were obtained from an agreement with the Anadarko Production Company.

This study updates the previous interpretations (Nordquist, 1984) and attempts to correlate these results with geologic data from UNOCAL's gradient hole program and the Oxy-Phillips deep test well, 17A-6. Subsurface drilling targets are subsequently identified based on resistivity anomalies and their correspondence with basement structures.

#### 4. Geologic and Structural Setting

The MLV is a broad Quaternary shield volcano with a diameter of about 20 miles which converges upward to a roughly elliptical rampart of cones and domes four-by-six miles in diameter, interpreted by Anderson (1941) as a collapsed "caldera" and henceforth referred to as the summit basin. The most recent activity, less than 1100 years ago, in the vicinity of the summit basin has been the extrusion of the Glass Mountain rhyolite-dacite, the Little Glass Mountain-Crater Glass Flow rhyolites and the Medicine Lake dacite. On the flanks of the volcano, there are many young basaltic scoria and cinder cones of less than 10,000 years, as well as extensive flows of basalt to the north and south which are less than 1100 years old.

The MLV is located on the western margin of the Basin and Range province. Basin and Range type block faulting with dominant north-northwest and north-south trends are common north and south of the volcano. Heiken (1978) believes the volcano has formed at the intersection of two major sets of normal faults, one trending north-south, the other, northwest. An alternative interpretation suggests that the volcano may have formed along structures at the edge of a large structural depression, defined by a gravity low, between Mt. Shasta and the MLV (Blakely et al, 1985).

On the highland, the dominant trends are northeast extensional faults located near Little Glass Mountain (LGM) and Lyons peak (McDannel and Bodell, 1985). Minor northwest and localized east-west structures and lineaments are also observed.

The only active surficial hydrothermal area is located at the Hot Spot, west of Glass Mountain, where temperatures greater than 175 degrees fahrenheit occur at 1.5 foot depths over an area of about one acre (Eichelberger, 1975). The other locations of surficial alteration are located near Schonchin and Crystal springs, west and south of Medicine Lake, respectively (Hausback, 1983).

#### 5. Exploration Model

The lack of a major surficial hydrothermal system on the MLV could be the result of a thorough dilution of the geothermal fluids by downward-percolating meteoric waters (Mass et al., 1982) and/or a sealing of the system from the surface by a non-permeable alteration cap. Assuming there are adequate reservoir temperatures within

drillable depths beneath the MLV, the goal for an exploration program is to delineate areas with sufficient porosities and permeabilities for geothermal exploitation.

Such zones could occur around subsurface structures such as faults or the edges of an intrusive where there may be fracturing of the surrounding rocks. An integration of gravity and electromagnetic data can help to delineate these structures and identify prospective areas to acquire land in a lease sale and to target future deep drilling efforts.

## 6. Geophysics Review

The MLV is defined geophysically by an unusually shallow (less than 8000 feet) dense, resistive and high-velocity zone of rocks, centered below the summit basin. These rocks are probably an assemblage of mafic dikes and large plutons. A zone of shallow low resistivities at less than 1500 feet below the surface is coincident with the top of the shallow resistive rocks.

A microearthquake evaluation of the volcano showed the area to be aseismic; no earthquakes greater than magnitude one occurred during a five-month period (Daniel and Foxall, 1985). Based on data from a USGS seismometer site maintained at Little Mt. Hoffman, the area has been aseismic for at least the last decade. This has not been the case historically, however, as implied by the young (less than 1100 years) extensional faults mapped by Hausback (1983) near LGM and Lyons Peak.

Citing the compositional similarity of the widely-spaced LGM and Glass Mountain eruptions, Heiken (1978) has suggested the existence of a large silicic magma chamber beneath the MLV. However, none of the available geophysics has detected a large magma body, suggesting that the silicic magma bodies may be nonexistent or could be small and short lived (Donnelly-Nolen, 1985). A high-resolution, active, seismic-imaging experiment performed jointly by the USGS and Lawrence Livermore National Laboratory in September, 1985 may help to resolve these questions (Berge et al., 1985). The results from this study should be available sometime in 1986.

## 7. Gravity

Plate 1 shows the updated gravity map, including 391 new sites obtained from the Santa Fe Geothermal Co. and 373 sites collected by UNOCAL in 1985. An approximate 30 mgal high is centered under the MLV. Its peak is located just northeast of Medicine Lake, and a high plateau extends southwest to near LGM. The size and shape of the anomaly reflect the approximate dimensions and areal extent of the near-surface, high-density rocks.

Four two-dimensional (2-D) gravity cross-sections across the anomaly (Plate 2) were modeled and constrained with results from

one-dimensional (1-D) MT models (Figures 1 through 5). The gravity data were upward continued to a surface of 8000 feet above sea level to assure the gravity and MT layer thicknesses could be accurately compared because the study area has a topographic relief of about 4000 feet.

The first and third layers of the models are assumed to represent young, unaltered surficial volcanics and basement rocks, respectively. The second layer corresponds to a conductive layer delineated with MT and is probably altered and porous. The densities selected for these layers are not well determined, but they are reasonable for the observed surficial and inferred intermediate to silicic basement rocks and show a fair agreement with measured values from four shallow gradient holes (personal communication R. Dickerson; Telford et al., 1976).

The MT and gravity results suggest that the basement depths change abruptly, sometimes as much as several thousand feet, near the summit basin. These basement structures could be faults or the edges of intrusives and are often coincident with zones of anomalously shallow low resistivities and unusually low basement resistivities (Figures 3 and 5).

The area of the highest observed gravity does not correspond to an unusually shallow MT basement (Figures 1 and 5). Gravity models show that the data can be fit equally well with an intrusive ("intrusive" model) or an increased density within the second layer ("cementation" model), Figures 1 and 2.

For the "intrusive" model, the top of the high density zone (2.8 gm/cc) is constrained by Well 17A-6 which encountered intermediate to silicic intrusive rocks at these depths (Figure 1). This zone could consist of one or more intrusives intruded along a zone of weakness.

Alternatively, the "cementation" model assumes that the higher resistivities observed in the second layer (Figure 2) are due to lower porosities caused by hydrothermal cementation. A simple calculation with Archie's Law indicates a change from about 31 to 18 percent porosity is required for the observed resistivity change. This is consistent with the density variation (.15 gm/cc) used for the model.

Unfortunately, the non-uniqueness inherent in gravity interpretation makes it impossible to distinguish between the two models. At this time, the "intrusive" model is preferred because of the constraints from Well 17A-6. However, there could also be some cementation and thus lower porosities in the second layer.

## 8. TDEM

Plate 2 shows the location of the concentric loop TDEM sites measured to date in the vicinity of the MLH, including 39 new sites

measured for UNOCAL (EMS, 1985) and 10 USGS sites (Anderson et al, 1983). Twelve of the new UNOCAL sites were located west of the Lava Beds National Monument to investigate a postulated near-surface intrusive near The Three Sisters (Nordquist, 1984).

These data are generally of very high quality and can be matched to 1-D models of two to four layers, with the resistivity decreasing with depth. The depth of investigation of less than 3500 feet is not deep enough to detect the resistive basement. For a few of the USGS sites (11, 13, 15, 18, and 19), a basal resistor is postulated, but probably not warranted because the data for these sites can be matched equally well without the resistor.

Plate 3 shows a plan map of the observed apparent resistivity at 2.2 msec and has a depth of investigation ranging from about 700 to 2500 feet. The area of low-resistivity, constrained by the 300 ohm-m contour, strikes northeast and is centered over Medicine Lake. The lowest resistivities are observed west of Glass Mountain, near Telephone Flat and south of Medicine Lake. These anomalies probably delineate zones of near-surface alteration and/or water table.

A resistivity low located west of the Lava Beds National Monument, near Mt. Dome, is probably a shallow feature and due to clay-rich lacustrine sediments seen at these stations.

#### 9. MT

The approximate locations for 46 Controlled Source Audio Magneto-telluric (CSAMT) sites and two MT sites, obtained from the Anadarko Production Company (Appendix 1), are shown in Figure 6. These data are combined with MT data collected for UNOCAL by WCC (1981) and CGG (1982) and contoured at 1 Hz for an average depth of investigation of about 9000 feet. The figure shows two areas of low-resistivity (less than 10 ohm-m) located near the east and west rims of the summit basin and separated by a northeast trending high resistivity ridge. The addition of these new CSAMT data indicates that the large low-resistivity zone in the east extends northeast through the Hot Spot along a narrow lens to near Indian Butte. The extension of the low-resistivity zone is not present at 10 Hz indicating the 1 Hz anomaly is due to a narrow deep source, possibly fault controlled.

#### 10. Geoelectric Cross-Sections

Seven geoelectric cross-sections, whose locations are show on Plate 2, were constructed using 1-D models from MT and TDEM stations (Plates 4 - 10). The sections show a consistent structure composed of four layers whose resistivities are defined by: Layer I, greater than 1000 ohm-m; Layer II, less than 1000 ohm-m; Layer III, less than 40 ohm-m; and Layer IV, greater than 100 ohm-m.

Coinciding geologic cross-sections compiled by R. Gunderson from

gradient holes shows that Layer I correlates with the observed thickness of surficial unaltered basalt, rhyolite, and dacite flow rocks. Layer II and Layer III correlate with a zone containing unaltered to moderately-altered basalts and andesites with occasional thick (greater than 500 feet) rhyolite and dacite flows. The conductive layer (III) does not correlate with a stratigraphic boundary but probably delineates a zone whose low bulk resistivities reflect increased porosity, clay alteration, and water content. The resistive basement (Layer IV) domes up under the summit basin and consists of strongly altered Tertiary volcanic flows and breccias capping weakly altered to unaltered intermediate to silicic intrusive rocks beneath the deep well 17A-6. A Schlumberger electric log from 17A-6 supports the MT data (Figure 7) and indicates the layer is resistive and thus probably contains little or no fluid.

An area of shallow low resistivities is observed over the upwarped resistive basement. The edges of the zone are usually associated with offsets in the resistive basement, some as large as 5000 feet, whose lateral locations are determined with gravity models. An area of generally higher resistivities within this zone is centered near Medicine Lake coincident with a gravity high and may indicate localized lower porosities (see discussion on gravity).

Anomalously low basement resistivities (less than 100 ohm-m) are coincident with offsets in the basement along Lines A, D, E and G and coincide with the edge of a postulated intrusive from gravity models on Lines D and G (Plates 4, 7, 8 and 10; Figures 3 and 5). If these basement offsets are due to faulting or reflect the edge of intrusives beneath the summit basin, the apparent anomalous low basement resistivities may indicate increased porosities associated with these structures.

The area west of Lava Beds National Monument is transected by Line D (Plate 7). These stations show a resistivity pattern consistent with those observed over the MLV but with lower surficial resistivities and no indication of an anomalously shallow low-resistivity zone due to hydrothermal alteration.

## 11. Summary of Gravity and EM Results

Figure 8 shows the depth of the resistive and dense basement as constrained by 1-D MT and 2-D gravity models. The unusually shallow basement trends northeast and has vertical offsets which range from about 1000 feet to as large as 5000 feet. Drilling information from Well 17A-6 indicates that a large intrusive or system of intrusions may have intruded into the basement northeast of Medicine Lake. The areal extent of the intrusive is constrained by the 2-D gravity results (Figure 9).

The plan map of MT resistivities at 1 Hz (depth of investigation approximately 9000 feet) delineates two large low-resistivity zones

of less than 10 ohm-m. The low resistivities are located on the east and west sides of the postulated intrusive, and they overlap areas of basement offsets (Figure 9). For many cases the basement offsets and the edges of the intrusive are associated with unusually low MT basement resistivities of less than 100 ohm-m. The low MT resistivities may be due to high porosities and increased water content related to high fracture porosities and permeabilities associated with the basement structures.

Primary drill targets should be centered within the 10 ohm-m MT anomaly and located near the edge of the postulated intrusive or targeted to intersect the basement offsets (Figure 9). These proposed targets will test the hypothesis of increased fracturing associated with these structures.



## 12. References

- Anderson, C. A. 1941 Volcanos of the Medicine Lake Highland, California, University of California Berkeley, Publ. Geol. Sci. V. 25, pp. 345-423
- Anderson, W. L., et al. 1983 Inversion Results of Time Domain Electromagnetic Soundings Near Medicine Lake, California, Geothermal Area, Open-File Report 82-233, 31 pp.
- Anderson, W. L., et al. 1983 Inversion of Time-Domain Electromagnetic Soundings Near Medicine Lake, California, Part 2, Open-File Report 83-910, 29 pp.
- Berge, P. A., et al. 1985 Active Seismic Imaging Experiment, EOS, August 20, 1985
- Blakely, R. G., et al. 1985 Tectonic Setting of the Southern Cascade Range As Interpreted From Its Magnetic and Gravity Fields, GSA Bulletin, V.96, pp. 43-48
- CGG 1982 MT Survey, Glass Mountain Prospect: Prepared for UNOCAL Geothermal
- Daniel, R. G. and Foxall, B. 1985 Microearthquake Monitoring at Medicine Lake Prospect, California, UNOCAL
- Donnelly-Nolan, J. M. 1985 Geothermal Potential of Medicine Lake Volcano, In Proceedings of the Workshop on Geothermal Recourses of the Cascade Range, USGS Open-File Report 85-521
- Eichelberger, J. C. 1975 Origin of Andesite and Dacite, Evidence of Mixing at Glass Mountain and at Other Circum-Pacific Volcanoes, Geol. Soc. Am. Bull., V.86, pp. 1381-1391

EM Surveys, Inc.	1982	TEM Data Sounding Test Survey at Glass Mountain - Medicine Lake, Northern California; Prepared for Occidental Petroleum
EM Surveys, Inc.	1983	TEM Central Induction Soundings, Siskiyou County, California; Prepared for UNOCAL Geothermal
EM Surveys, Inc.	1985	TEM Central Induction Sounding, Glass Mountain Prospect, California; Prepared for UNOCAL Geothermal
Hausback, B. P.	1983	Geologic Map of Medicine Lake Highland, 1:24,000, UNOCAL
Heiken, G.	1978	Plinian-Type Eruptions in the Medicine Lake Highland, California, and the Nature of the Underlying Magma, Journ. Volc. Geoth. Res., V.4, pp. 375-402
Mass, C. W., et al.	1982	Preliminary Heat-Flow Investigations of the California Cascades, USGS Open-File Report 82-150, 240 pp.
McDannel, A. and Bodell, J.	1985	Structural Study of the Medicine Lake Highland, UNOCAL
Nordquist, G. A.	1984	Geophysical Interpretation of the Mt. Shasta - Medicine Lake Areas, UNOCAL
Stark, M. A.	1985	New Techniques for Integration of TDEM and MT Data: The Number 5, UNOCAL
Telford, W. M., et al.	1977	Applied Geophysics, Cambridge University Press, 860 pp.
Woodward-Clyde Consultants	1981	MT Survey, Glass Mountain Prospect, Prepared for UNOCAL Geothermal

13. List of Figures

<u>Figure</u>	<u>Description</u>
1	2-D Gravity Model Line C-C' "Intrusive" Model Constrained with MT
2	2-D Gravity Model Line C-C' "Cementation" Alternative Model Constrained with MT
3	2-D Gravity Model Line D-D' "Intrusive" Model Constrained with MT
4	2-D Gravity Model Line F-F' "Intrusive" Model Constrained with MT
5	2-D Gravity Model Line G-G' "Intrusive" Model Constrained with MT
6	Medicine Lake Highland: MT Invariant Resistivity at 1 Hz
7	Glass Mountain Federal Well 17A-6: Schlumberger Dual Induction Resistivity Log, Averaged at 100-foot intervals
8	Medicine Lake Highland: Depth to Resistive/Dense Basement Constrained with MT and Gravity
9	Medicine Lake Highland: Proposed Sites For Deep Production Tests

14. List of Plates

<u>Plate</u>	<u>Description</u>
1	Medicine Lake Highland: Complete Bouguer Map; Reduction Density 2.45 gm/cc; Scale 1:125,000
2	Medicine Lake Highland: Location of Geoelectric and Gravity Cross Sections with Locations for TDEM and MT Stations; Scale 1:125,000
3	Medicine Lake Highland: TDEM Apparent Resistivity at 2.2 msec; Scale 1:125,000
4	Geoelectric Cross-Section Line A-A'
5	Geoelectric Cross-Section Line B-B'
6	Geoelectric Cross-Section Line C-C'
7	Geoelectric Cross-Section Line D-D'
8	Geoelectric Cross-Section Line E-E'
9	Geoelectric Cross-Section Line F-F'
10	Geoelectric Cross-Section Line G-G'

15. Appendix 1

Apparent resistivity data from 46 Controlled Source Audio Magnetotelluric (CSAMT) stations and two MT sites collected for the Anadarko Production Company by Zonge Engineering Inc. and Phoenix Corporation, respectively. These data are from notes taken by Gregg Nordquist at Anadarko's office in Santa Rosa, January 17, 1985. The stations' locations are only approximate (Figure 6), and the resistivities are equivalent to the invariant resistivity used for UNOCAL's MT data.

CSAMT Station No.	Apparent Resistivities		
	Frequency (Hz)		
	1 Hz	3 Hz	10 Hz
1	70	55	70
2	4	11	30
3	6	8	11
4	7	4	7
5	130	60	150
6	80	20	40
7	80	30	50
8	90	70	170
9	30	70	200
10	19	21	35
11	6	20	70
12	50	15	60
13	20	20	100
14	90	15	70
15	30	18	35
16	110	40	120
17	130	40	110
19	120	20	70
20	18	45	135
21	35	55	145
22	20	30	70
23	60	70	170
24	15	30	100
25	7	20	60
26	20	40	110
27	20	20	90
28	40	20	90
29	25	25	100
30	100	15	180
31	80	30	100
32	10	30	100
34	40	70	180
35	20	50	130
36	20	30	100
37	40	50	120
38	60	30	100

<u>CSAMT</u> <u>Station No.</u>	Apparent Resistivities		
	Frequency (Hz)		
	<u>1 Hz</u>	<u>3 Hz</u>	<u>10 Hz</u>
40	15	31	100
41	20	35	70
43	20	50	100
44	25	40	80
45	27	50	130
49	18	40	70
50	28	60	180
52	20	50	130
54	30	35	110
57	40	45	150

3495b

Invariant

MT SITES

Apparent Resistivity Frequency

(Hz)

	<u>30</u>	<u>3</u>	<u>1</u>	<u>.3</u>	<u>.1</u>	<u>.03</u>	<u>.01</u>
1	200	40	30	30	50	70	70
2	155	30	16	20	41	63	46

GAN/st-wjm  
3495b

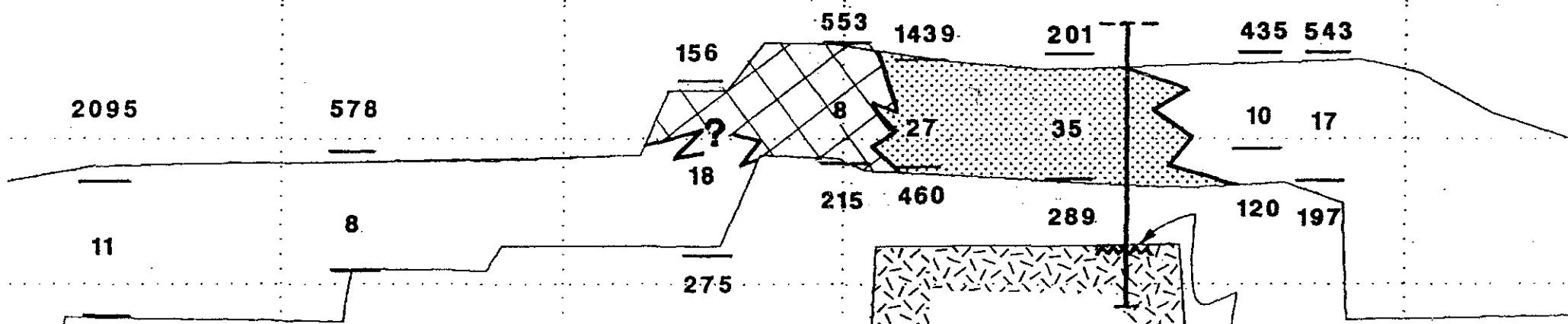
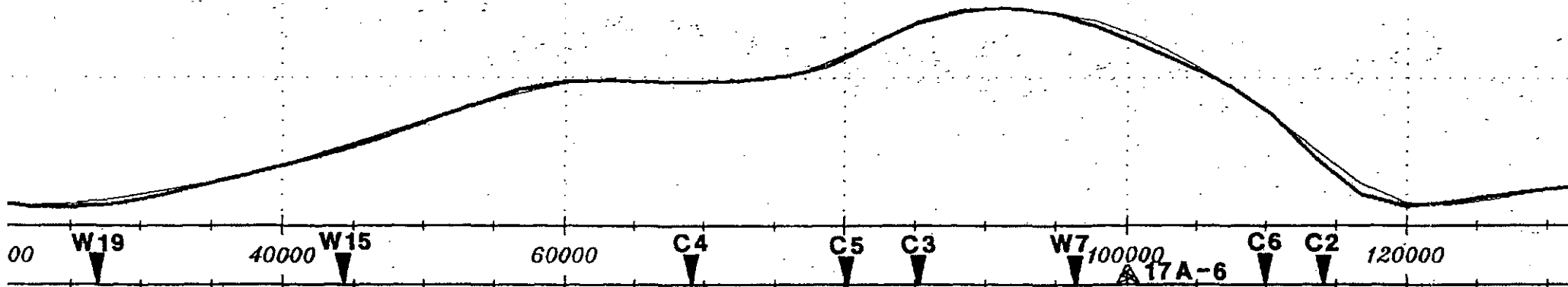

EAR-SURFACE  
 RESISTIVITIES  
 0 Ohm-m  
 m < Res. < 40 Ohm-m

00 40000 60000 80000 100000 120000  
 FEET  
**LAKE LINE C-C'**  
 10416.7 FT/IN VERTICAL SCALE = 5000.0 FT/IN  
 W: WCC 1981 Station #  
 C: CGG 1982  
 1500 One-Dimen  
 MT Models



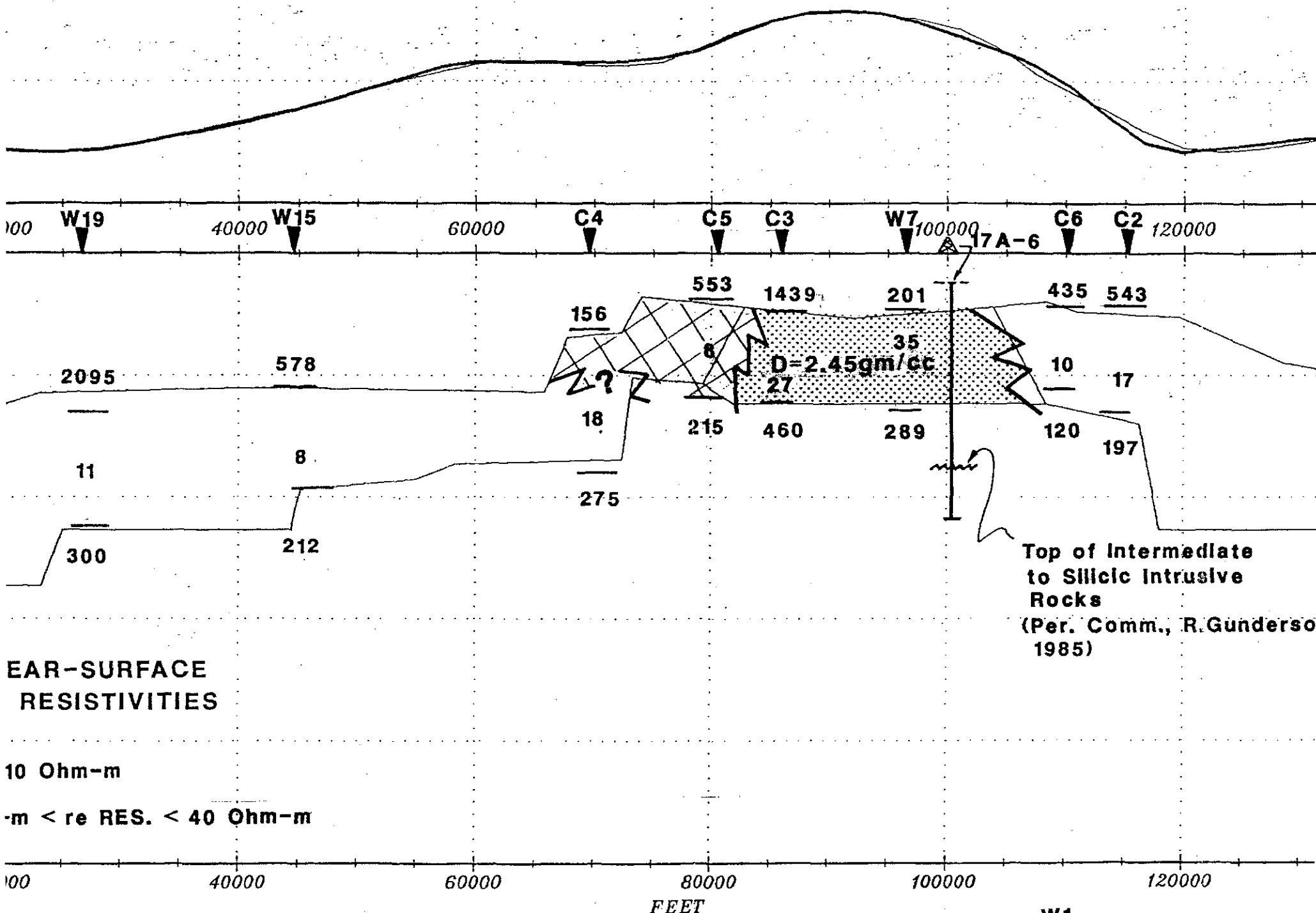

EAR-SURFACE  
RESISTIVITIES

10 Ohm-m  
 $10^{-m} < re RES. < 40 Ohm-m$

100 40000 60000 80000 100000 120000  
 FEET

LAKE LINE C-C'\*

10416.7 FT/IN VERTICAL SCALE = 5000.0 FT/IN

W: WCC 1981  
 C: CGG 1982  
 Station #  
 1500

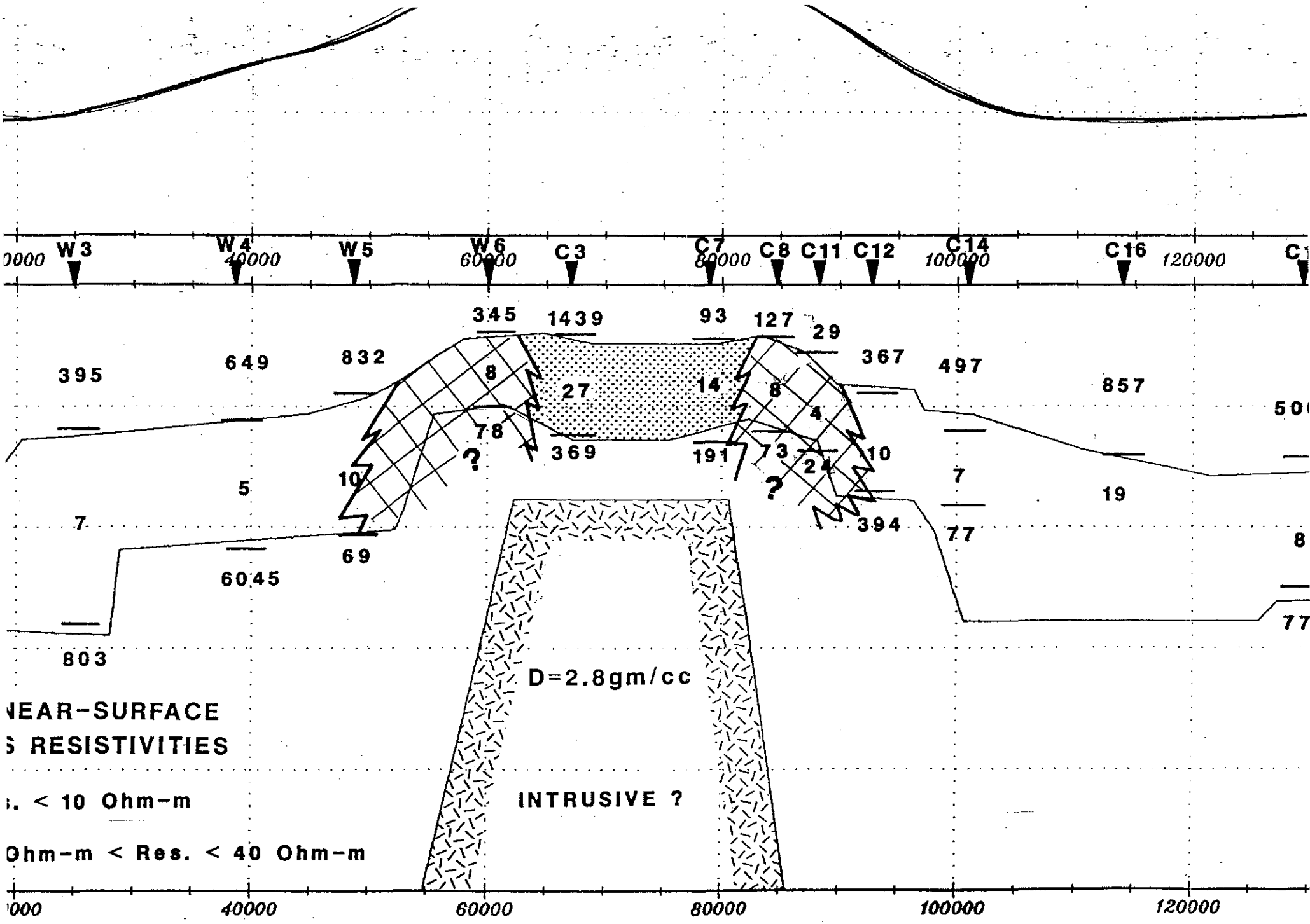

0000 W3 40000 W4 60000 W5 80000 W6 C3 80000 C7 C8 C11 C12 100000 C14 120000 C16 C17

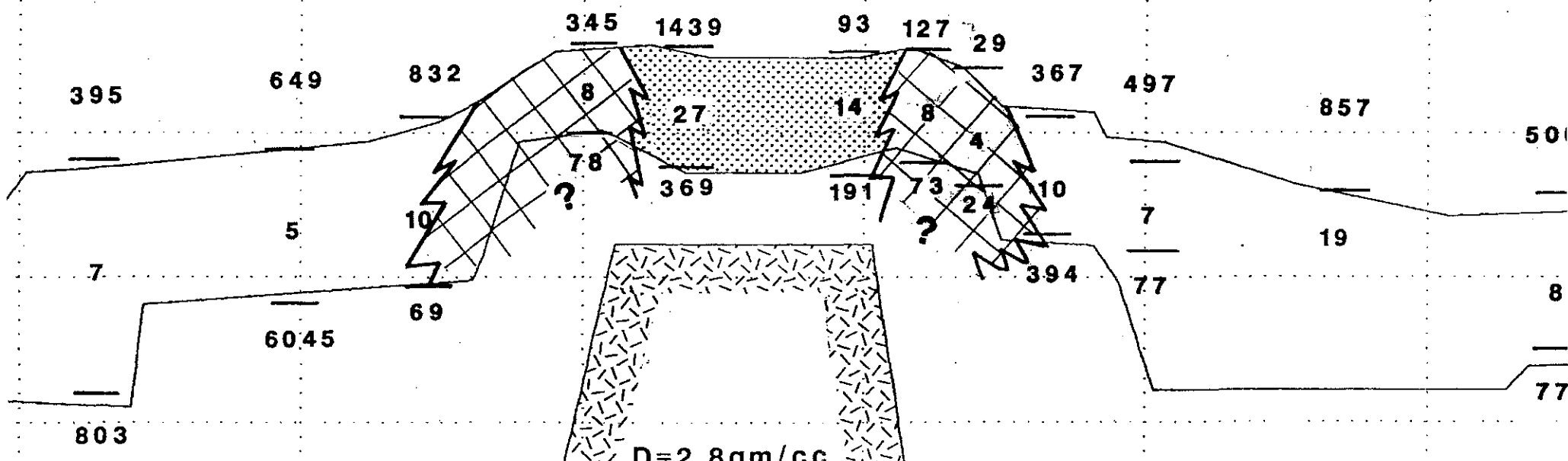

LAKE LINE D-D'

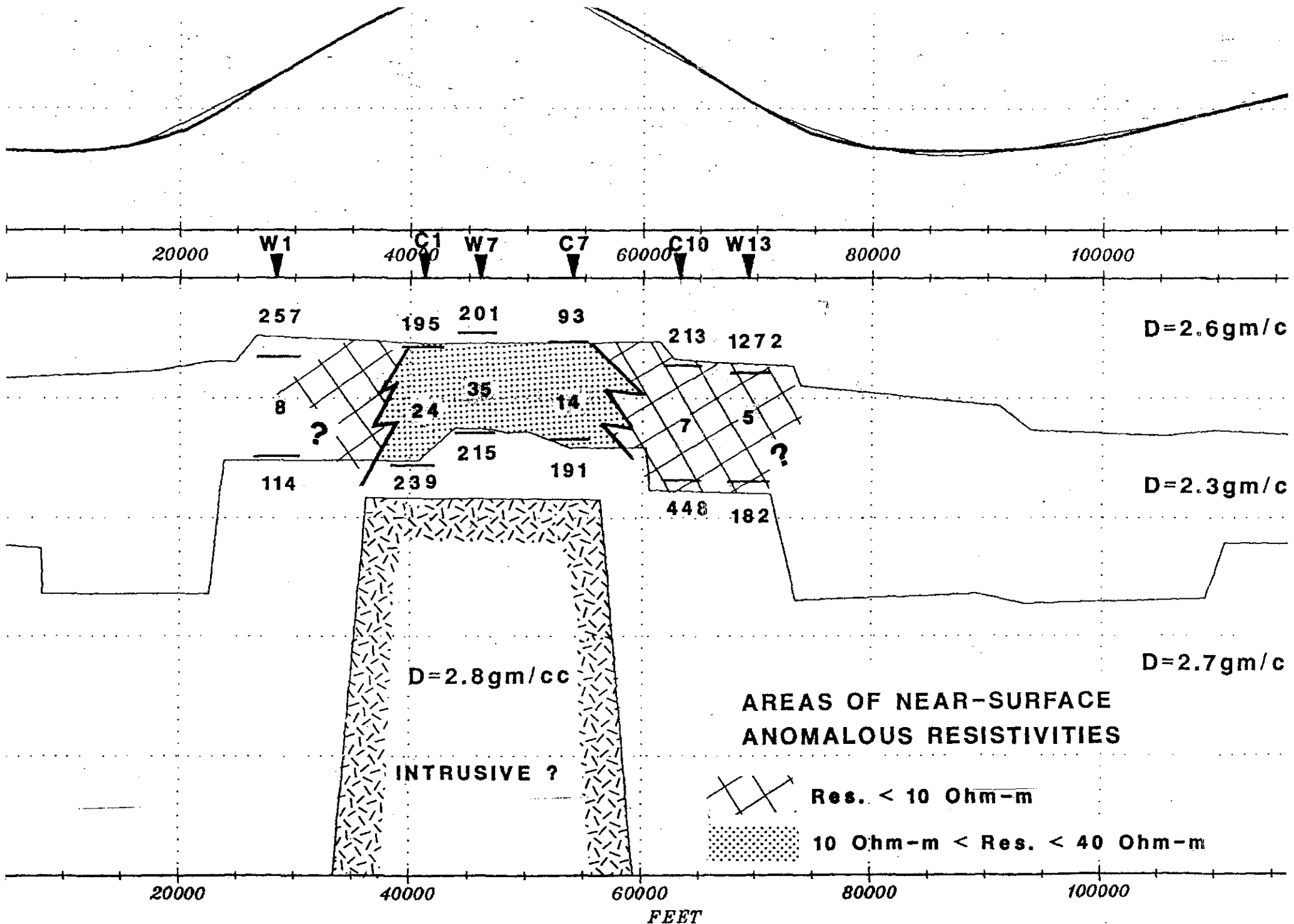

MEDICINE LAKE LINE F-F'

W: WCC 1981 Station #  
 C: CCC 1982

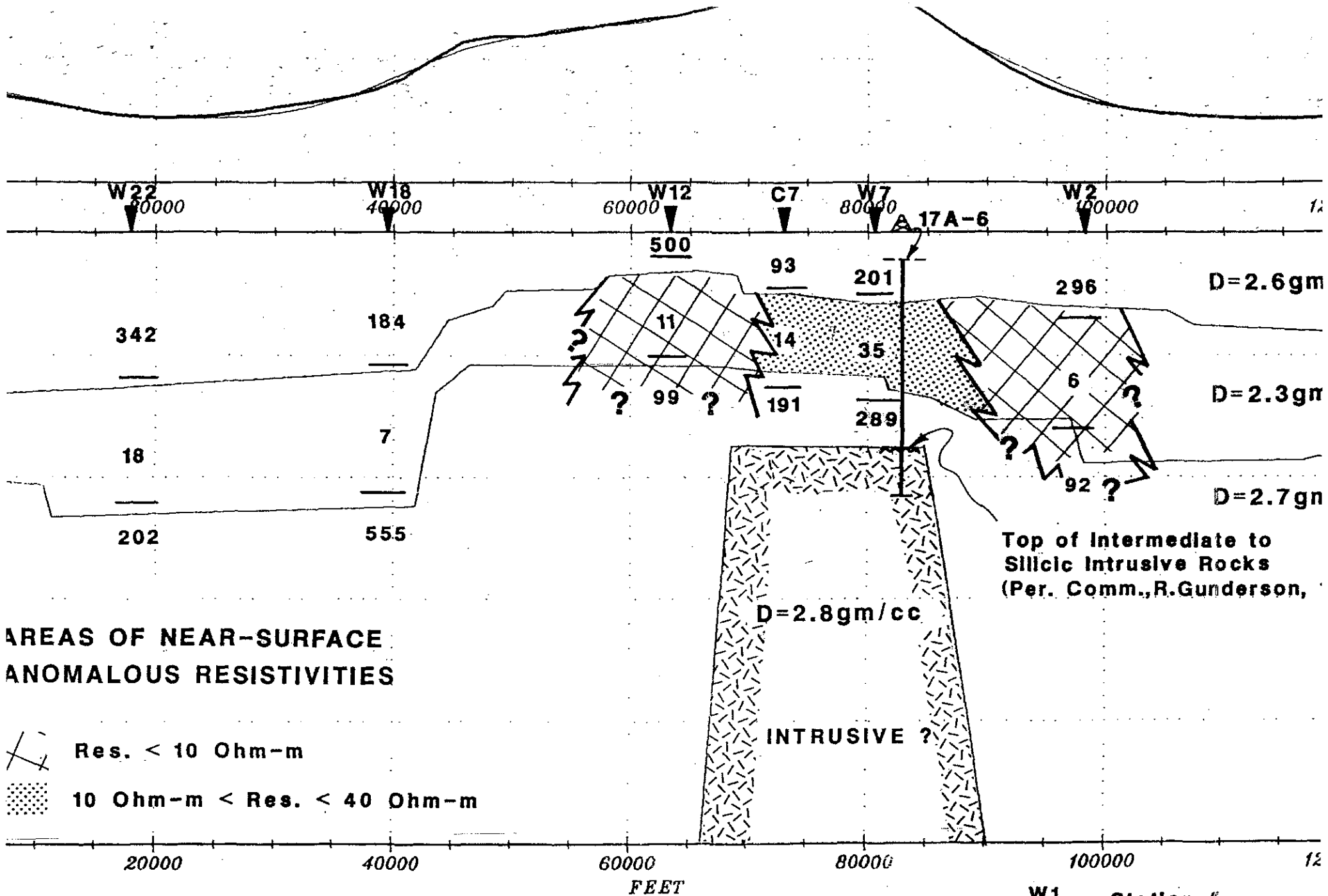

**AREAS OF NEAR-SURFACE ANOMALOUS RESISTIVITIES**

- Res. < 10 Ohm-m
- 10 Ohm-m < Res. < 40 Ohm-m

**MICINE LAKE LINE G-G'**

HORIZONTAL SCALE = 10416.7 FT/IN  
 DENSITY = 2.70 GM/CC

VERTICAL SCALE = 5000.0 FT/IN

W: WCC 1981  
 C: CGG 1982

Station #  
 One-Dimensional MT Models

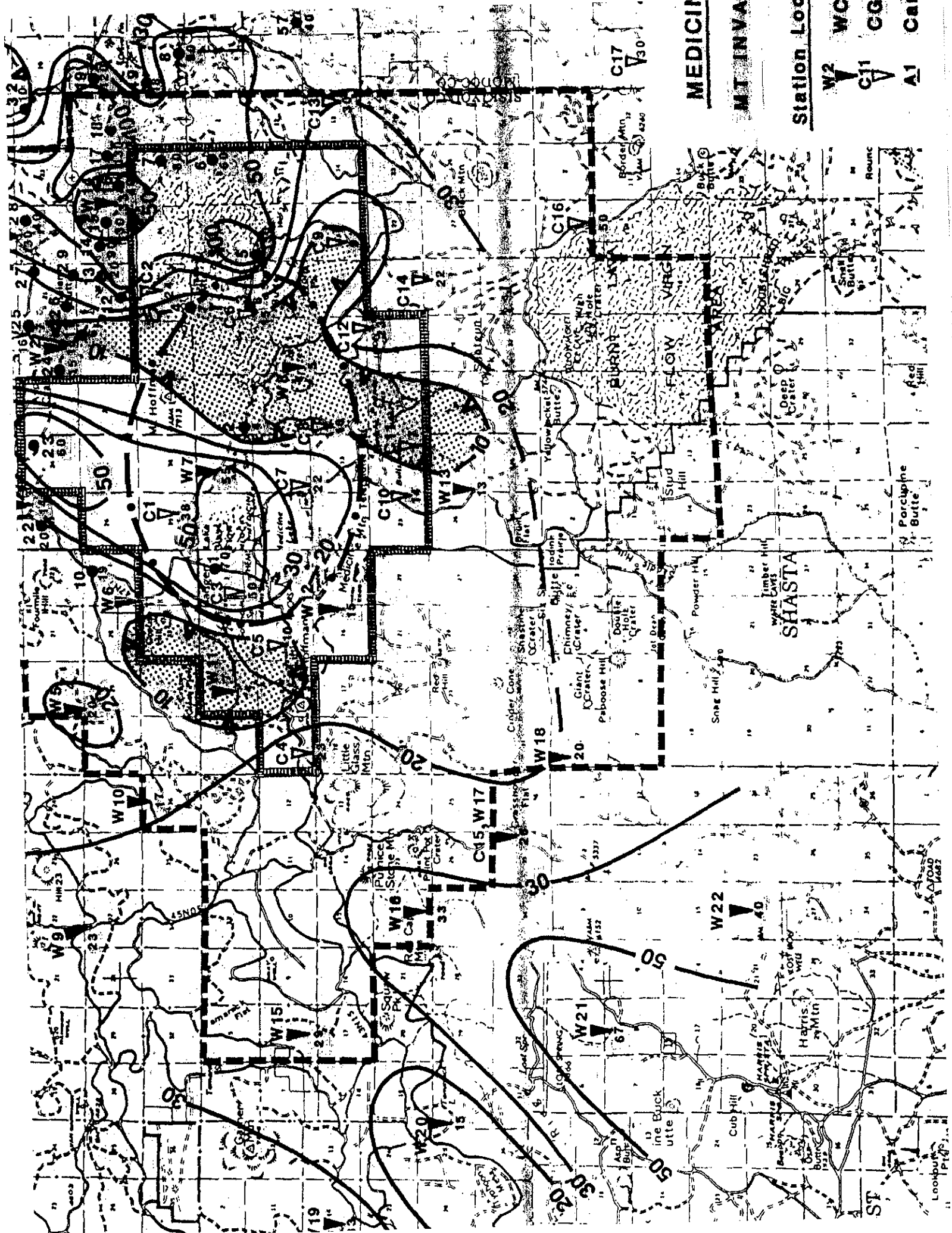

**MEDICII**

**MT INVA**

**Station Loc**

- W2
- C11
- A1
- WC
- CG
- Car

**SHASTA**

**ST**

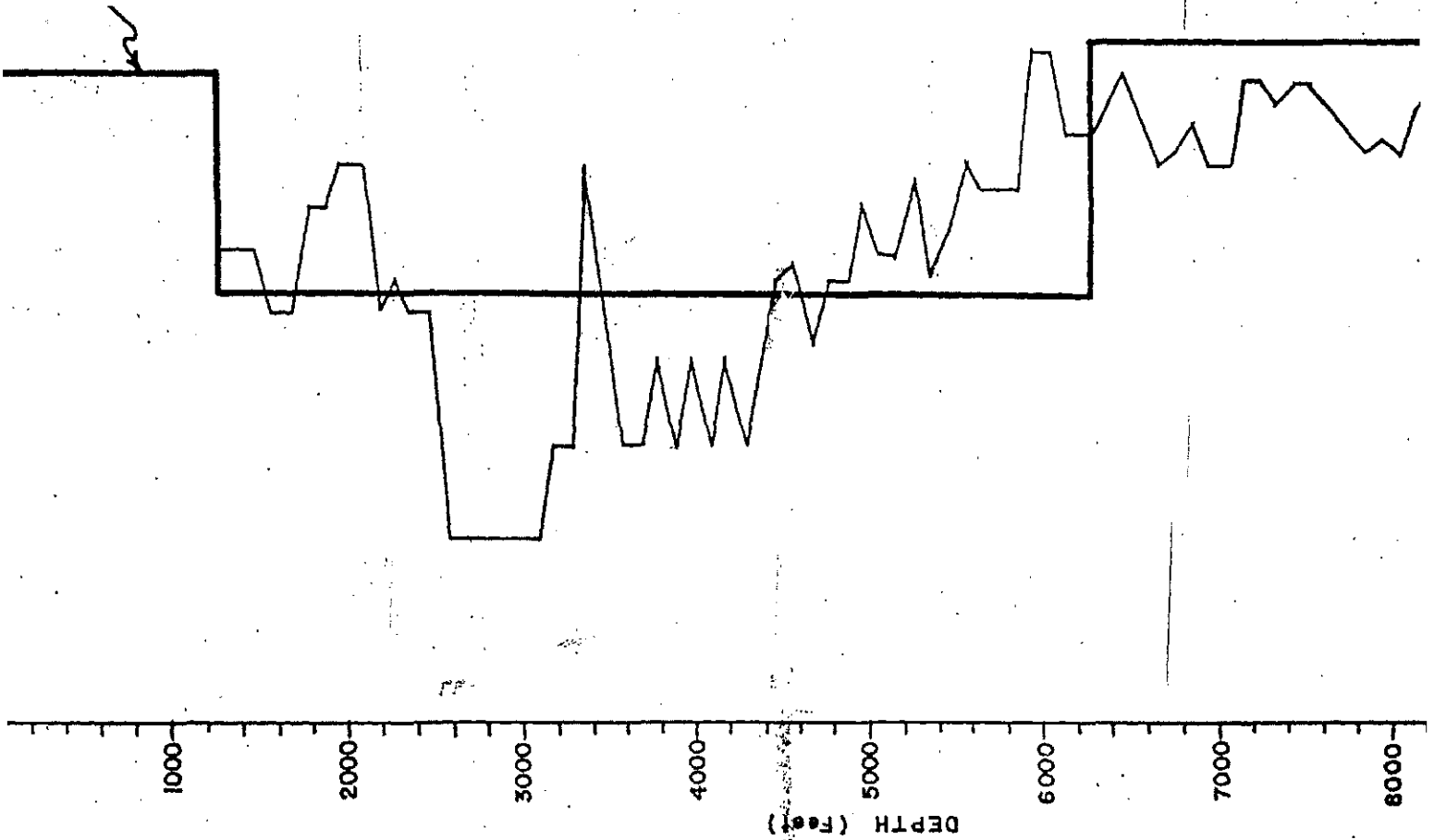

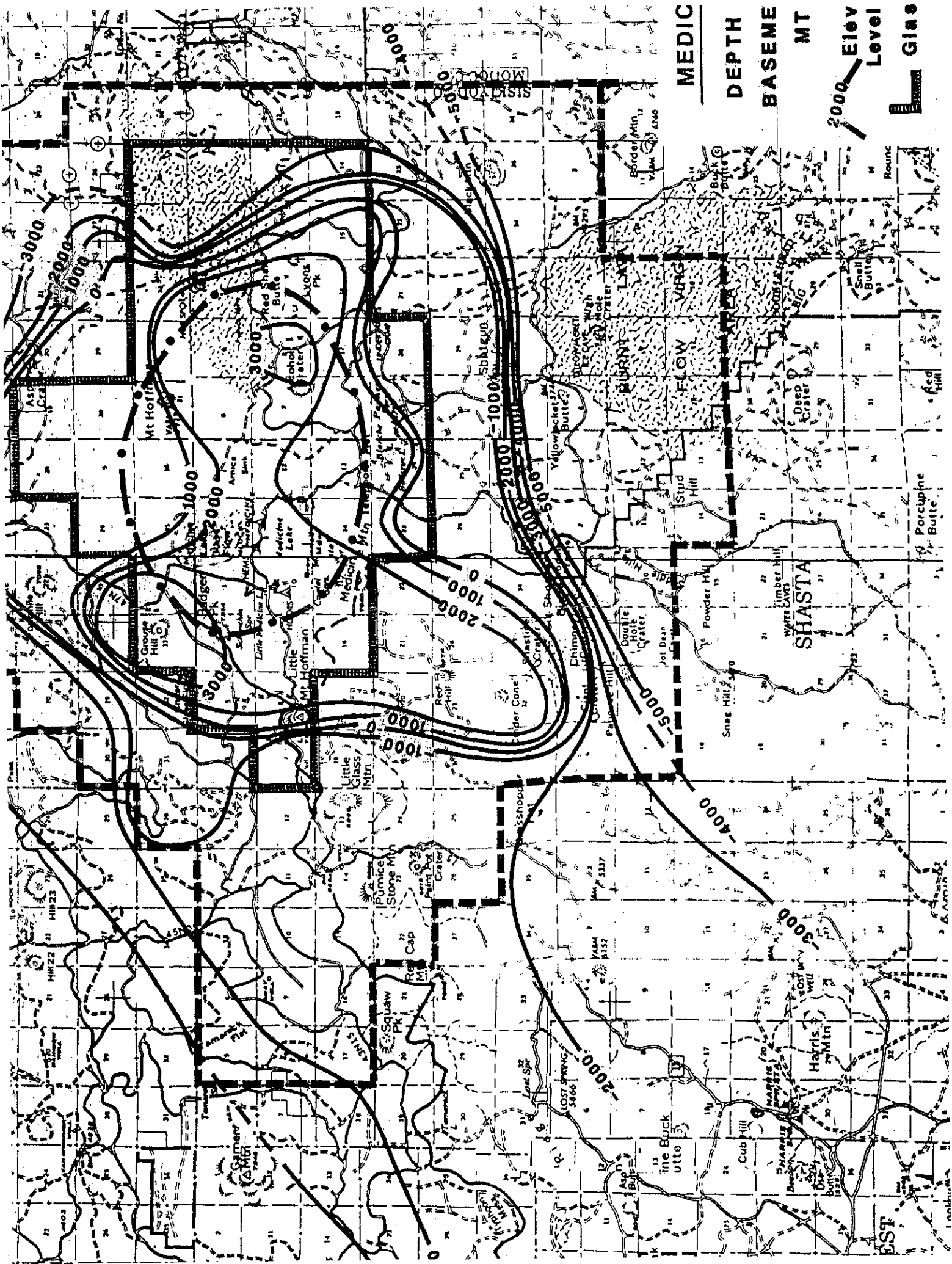

MEDIC

DEPTH

BASEME

MT

ELEV  
Level

Glas

2000

SHASTA

EST

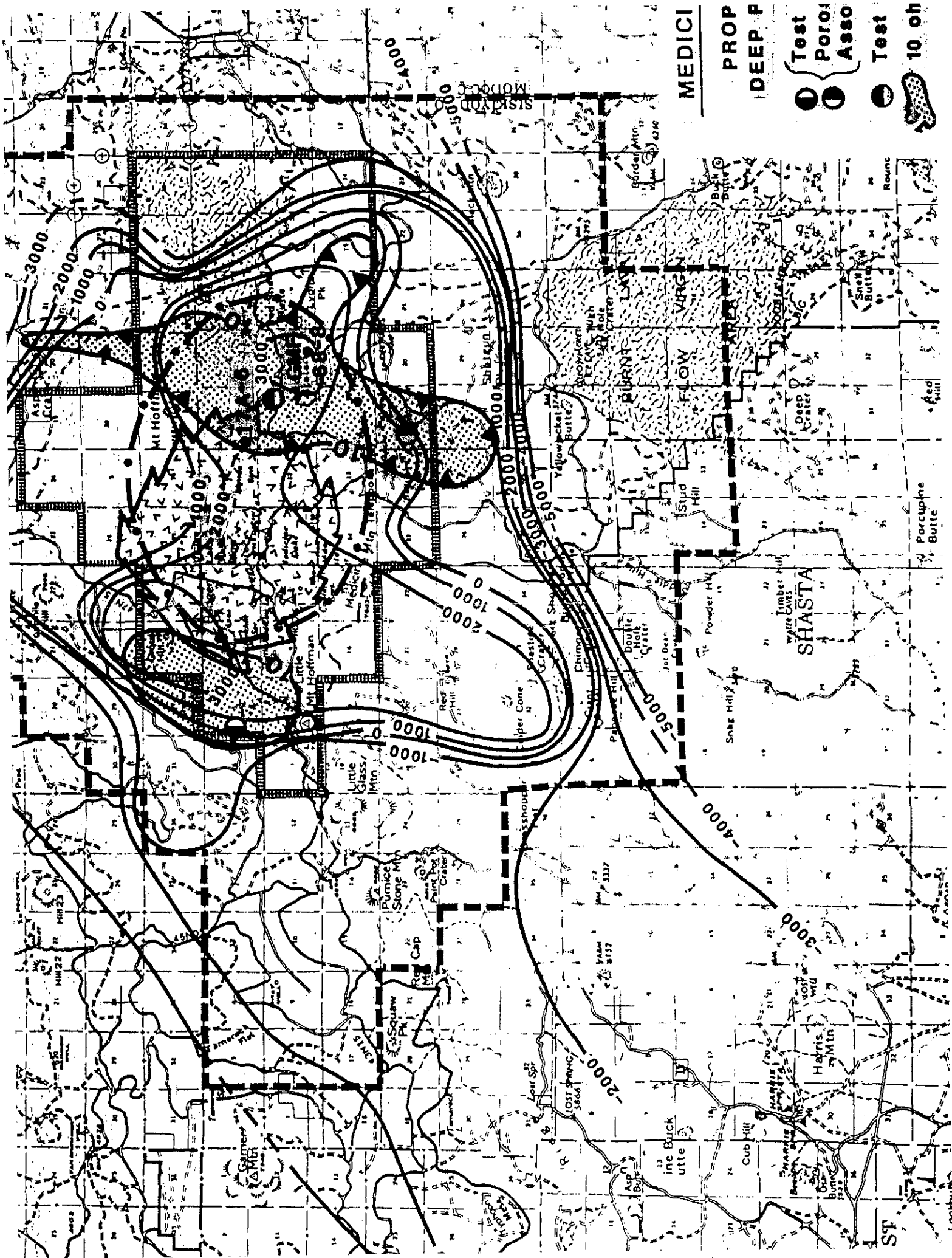

MEDICI

PROP DEEP F

- Test
- Poroi
- Asso
- Test
- 10 oh

SHASTA

ST